

**(12) STANDARD PATENT**  
**(19) AUSTRALIAN PATENT OFFICE**

(11) Application No. **AU 2017380595 B2**

(54) Title  
**Compositions comprising acetic acid and hypochlorous acid and methods for treating biofilm**

(51) International Patent Classification(s)  
**A01N 59/00** (2006.01)                      **A61K 31/19** (2006.01)  
**A61K 8/20** (2006.01)                      **C01B 11/04** (2006.01)  
**A61K 8/36** (2006.01)

(21) Application No: **2017380595**                      (22) Date of Filing: **2017.12.22**

(87) WIPO No: **WO18/115977**

(30) Priority Data

(31) Number	(32) Date	(33) Country
<b>62/438,198</b>	<b>2016.12.22</b>	<b>US</b>
<b>62/438,204</b>	<b>2016.12.22</b>	<b>US</b>
<b>62/438,189</b>	<b>2016.12.22</b>	<b>US</b>
<b>15/612,571</b>	<b>2017.06.02</b>	<b>US</b>
<b>62/438,202</b>	<b>2016.12.22</b>	<b>US</b>

(43) Publication Date: **2018.06.28**

(44) Accepted Journal Date: **2023.03.02**

(71) Applicant(s)  
**WIAB Water Innovation AB**

(72) Inventor(s)  
**Almas, Geir Hermod**

(74) Agent / Attorney  
**Spruson & Ferguson, GPO Box 3898, Sydney, NSW, 2001, AU**

(56) Related Art  
**US 2016/0271171 A1**  
**US 2015/0150907 A1**  
**EP 1829449 A1**

(12) INTERNATIONAL APPLICATION PUBLISHED UNDER THE PATENT COOPERATION TREATY (PCT)

(19) World Intellectual Property  
Organization

International Bureau

(43) International Publication Date  
28 June 2018 (28.06.2018)



(10) International Publication Number  
**WO 2018/115977 A1**

(51) International Patent Classification:

*A01N 59/00* (2006.01)      *A61K 31/19* (2006.01)  
*A61K 8/36* (2006.01)      *C01B 11/04* (2006.01)  
*A61K 8/20* (2006.01)

**Published:**

- with international search report (Art. 21(3))
- before the expiration of the time limit for amending the claims and to be republished in the event of receipt of amendments (Rule 48.2(h))

(21) International Application Number:

PCT/IB2017/001728

(22) International Filing Date:

22 December 2017 (22.12.2017)

(25) Filing Language:

English

(26) Publication Language:

English

(30) Priority Data:

62/438,189      22 December 2016 (22.12.2016)      US  
62/438,198      22 December 2016 (22.12.2016)      US  
62/438,204      22 December 2016 (22.12.2016)      US  
62/438,202      22 December 2016 (22.12.2016)      US  
15/612,571      02 June 2017 (02.06.2017)      US

(71) Applicant: **SOFTOX SOLUTIONS AS** [NO/NO];  
Forskningsparken (oslo Science Park), Gustadalleen 21,  
0349 Oslo (NO).

(72) Inventor: **ALMAS, Geir, Hermod**; Norstrandsveien 17 A,  
1170 Oslo (NO).

(74) Agent: **MEYERS, Thomas, C.** et al.; Brown Rudnick LLP,  
One Financial Center, Boston, MA 02111 (US).

(81) Designated States (unless otherwise indicated, for every kind of national protection available): AE, AG, AL, AM, AO, AT, AU, AZ, BA, BB, BG, BH, BN, BR, BW, BY, BZ, CA, CH, CL, CN, CO, CR, CU, CZ, DE, DJ, DK, DM, DO, DZ, EC, EE, EG, ES, FI, GB, GD, GE, GH, GM, GT, HN, HR, HU, ID, IL, IN, IR, IS, JO, JP, KE, KG, KH, KN, KP, KR, KW, KZ, LA, LC, LK, LR, LS, LU, LY, MA, MD, ME, MG, MK, MN, MW, MX, MY, MZ, NA, NG, NI, NO, NZ, OM, PA, PE, PG, PH, PL, PT, QA, RO, RS, RU, RW, SA, SC, SD, SE, SG, SK, SL, SM, ST, SV, SY, TH, TJ, TM, TN, TR, TT, TZ, UA, UG, US, UZ, VC, VN, ZA, ZM, ZW.

(84) Designated States (unless otherwise indicated, for every kind of regional protection available): ARIPO (BW, GH, GM, KE, LR, LS, MW, MZ, NA, RW, SD, SL, ST, SZ, TZ, UG, ZM, ZW), Eurasian (AM, AZ, BY, KG, KZ, RU, TJ, TM), European (AL, AT, BE, BG, CH, CY, CZ, DE, DK, EE, ES, FI, FR, GB, GR, HR, HU, IE, IS, IT, LT, LU, LV, MC, MK, MT, NL, NO, PL, PT, RO, RS, SE, SI, SK, SM, TR), OAPI (BF, BJ, CF, CG, CI, CM, GA, GN, GQ, GW, KM, ML, MR, NE, SN, TD, TG).

(54) Title: COMPOSITIONS COMPRISING ACETIC ACID AND HYPOCHLOROUS ACID AND METHODS FOR TREATING BIOFILM

(57) Abstract: Disinfecting compositions containing hypochlorous acid and acetic acid are useful for treating biofilms in or on tissue, including biofilms related to wounds or other skin trauma. The compositions are useful for treating a variety of types of tissue, both on the surface on beneath the surface of tissue. Compositions are provided having various concentrations for different tissue types and infection levels. Compositions may be provided in gel form, and may include nanoparticle encapsulated molecules for controlled release.

WO 2018/115977 A1

COMPOSITIONS COMPRISING ACETIC ACID AND HYPOCHLOROUS ACID  
AND METHODS FOR TREATING BIOFILM

Related Applications

This application claims priority to and the benefit of U.S. Patent Application Serial No. 15/612,571, filed June 2, 2017; U.S. Provisional Patent Application Serial No. 62/438,189, filed December 22, 2016; U.S. Provisional Patent Application Serial No. 62/438,198, filed December 22, 2016; U.S. Provisional Patent Application Serial No. 62/438,202, filed December 22, 2016; and U.S. Provisional Patent Application Serial No. 62/438,204, filed December 22, 2016.

The contents of each of the above-referenced applications are incorporated by reference herein in their entirety.

Field of the Invention

The invention generally relates to compositions of acetic acid and hypochlorous acid for treating biofilms, particularly biofilms on tissue and in wounds, and also other biofilm infections.

Background

Microbial infections that produce biofilms can pose serious health problems. Scientists estimate that up to 80% of all infections affecting mammals are biofilm infections. Biofilms are particularly challenging in wound management. Medical professionals have long struggled to manage biofilms in wounds, including chronic wounds and wounds related to eczema. Bacteria such as *S. aureus* and *P. aeruginosa* create biofilms on and in wounds. These infections are difficult to eradicate and prevent wound healing. It has been noted, for example, that 93.5% of chronic leg ulcers contain *S. aureus* and 52.2% harbor *P. aeruginosa*, and ulcers containing *P. aeruginosa* are characterized by larger wound sizes and slower healing rates. *See Gjodsbol et al., 2006, International Wound Journal 3(3):225-31; and see also Fazli et al., 2009, Journal of Clinical Microbiology 47(12):4084-89.*

Prior art disinfecting compositions have various shortcomings. Some fail to penetrate deep enough into the wound to completely eradicate a biofilm that has taken hold beneath the surface. Others disperse too quickly and fail to attack the biofilm long enough to be effective. Still others have issues with product stability, requiring on-site production, which makes them

more difficult to use and less widely available. Other antimicrobial compositions are abrasive to tissue or otherwise incompatible with topical use.

### Summary

In a first aspect, the present invention provides an air-free antimicrobial composition comprising acetic acid and hypochlorous acid having a balanced concentration of each so as to achieve a synergistic effect resulting in the composition being sufficient to treat a bacterial biofilm without harming surrounding skin, wherein at least some of the acetic acid is encapsulated in a nanoparticle, and wherein the acetic acid has a concentration of approximately 2.0 wt % and the hypochlorous acid has a concentration of approximately 200 ppm.

Disinfectant compositions comprising hypochlorous acid and acetic acid as described herein are useful for treating biofilms in or on tissue, ranging from simple topical disinfectants to wounds or other skin trauma. For example, wounds are often susceptible to microbial infection, including biofilms that form on the surface and beneath the surface of a wound, which prevent healing and can lead to chronic conditions. Compositions comprising hypochlorous acid and acetic acid are useful for treating biofilms on tissue. The concentrations of HOCl and HAc are balanced in order to achieve a synergistic effect wherein the antimicrobial capabilities of the composition are greater than would be expected based on the antimicrobial properties of each component on its own. An acetic acid composition balanced with an amount of HOCl provides greater antimicrobial activity than acetic acid alone, often by several orders of magnitude. In addition, the hypochlorous acid modulates the toxicity of the acetic acid and provides an analgesic effect, allowing stronger compositions to be applied to skin or other tissue without adverse side effects or patient discomfort.

The disclosed compositions are useful for treating a variety of types of tissue, both on the surface and beneath the surface. The hypochlorous acid component is effective against surface-level biofilms or biofilm just below the surface of, for example, a wound, while the acetic acid penetrates deeper into a wound or tissue. Various compositions are described herein, having different concentrations of each acid component for treatment of diverse types of tissues and

wounds. Acetic acid concentrations greater than about 0.25% are useful for penetrating wound surfaces. Some compositions thus have acetic acid in concentrations of about 1.0%, about 2.0%, or higher, up to about 5.0%. Likewise, hypochlorous acid is found in different concentrations in the compositions depending on the type of tissue to be treated. For example, hypochlorous acid at 80 to 250 ppm is useful for treating a biofilm infecting the root of a tooth, while only 5-60 ppm is needed for a dental mouthwash composition. Compositions of the invention are particularly beneficial due to the synergistic balance between hypochlorous acid and acetic acid, which gives the compositions the dual effect of surface, just beneath surface, and deeper sub-surface treatment of biofilm infected tissue. In general, hypochlorous acid is able to act rapidly

at or near the surface; whereas acetic acid takes longer time to act and therefore can act below the wound surface.

Compositions of the invention may be provided as a gel or cream, which allows longer contact time with the tissue. For wound treatment, gels and cream compositions also help to keep the wound hydrated, promoting healing. Additionally, one or both of the components of inventive compositions can be encapsulated in a nanoparticle for controlled or delayed release.

The disclosed compositions and treatment methods are effective against biofilms wherever they are found, whether in a wound, on or in tissue, on non-tissue surfaces, or in pre-surgical or post-trauma settings. Application of the compositions to the site of skin trauma helps to combat microbial infection by preventing and treating bacterial infection, including biofilms. Compositions of the invention are useful for first-aid or in a surgical setting, for treating skin prior to, during, or after surgery. Disinfecting the area prior to surgical incision not only helps disinfect the operation area but also lessens the likelihood of infection spreading to other tissue during surgery. Hypochlorous acid and acetic acids compositions are also useful for debridement and cleaning of damaged tissue.

The compositions described herein can be combined with various excipients and carriers to facilitate topical administration. Hypochlorous acid (and organic acid) products can take the form of gels, creams, lotions, sprays, liquids, foams, powders, and other delivery formulations known in the art. Alternatively, the compositions can be provided incorporated into cloth or fibrous wipes or wound dressings.

Because the disclosed compositions are capable of penetrating into tissues, they are also effective for fighting biofilms below the surface of the wound, in subcutaneous tissue, such as in a tooth root, a surgical site, or a deep tissue wound.

In certain aspects, the invention includes a composition made up of acetic acid and hypochlorous acid. The acetic acid is present in concentrations greater than about 0.1%, and preferably greater than about 0.25%. A preferred hypochlorous acid concentration is between about 10 ppm and about 1000 ppm. In various embodiments the particular concentrations of acetic acid and hypochlorous acid depend on the intended treatment area and how deep beneath the surface of the tissue the treatment is desired.

In some embodiments, acetic acid is present in a concentration sufficient to penetrate beneath the surface of a tissue. In some embodiments, acetic acid concentration is greater than

about 0.5%, and preferably greater than about 1.0%, and in some embodiments it is about 2.0% or more. The acetic acid may be encapsulated in a nanoparticle for controlled or delayed release. In some embodiments, the hypochlorous acid is present in a concentration sufficient to treat biofilm on and just beneath a surface of a wound. The hypochlorous acid concentration may be between about 20 ppm and about 200 ppm. The composition may further include a gel, cream, ointment, or oil.

In related aspects, the invention involves a method for treating a biofilm in or on tissue. Methods include applying to a tissue a composition comprising acetic acid in a concentration sufficient to penetrate skin and hypochlorous acid in an amount sufficient to remove biofilm on and just beneath a surface of the tissue.

The acetic acid may be present in amounts sufficient to remove biofilm beneath the surface of skin. The acetic acid may be present in an amount from about 0.1% to about 2.0%, and the hypochlorous acid may be present in a concentration from about 10 ppm to about 1000 ppm.

In some embodiments, the tissue to be treated is bladder tissue and the hypochlorous acid concentration is about 80-250 ppm. In other embodiments, the tissue to be treated is lung tissue, and the hypochlorous acid concentration is about 15-60 ppm. In still other embodiments, the tissue to be treated is dental tissue, and the hypochlorous acid concentration is about 5-60 ppm, and the acetic acid concentration is between about 0.05% and about 5.0%.

In some embodiments, the biofilm to be treated is formed at a wound site, including the surface and beneath the surface of the wound. The acetic acid concentration for wound treatment may be between about 0.5% and about 5.0%.

In related aspects, a method for treating biofilm in tissue involves applying a nanoparticle comprising acetic acid to a tissue site in which biofilm formation is suspected. The nanoparticle may be lipid soluble.

#### Brief Description of the Drawings

Figure 1 is a schematic showing an exemplary system for producing hypochlorous acid according to methods of the invention.

Figure 2 is a schematic showing a magnified view of the mixing device shown in Figure 1.

Figure 3 is a schematic showing an internal view of the mixing chamber of the mixing device.

Figure 4 is a schematic showing a front view of the members that divide the mixing chamber into a plurality of sub-chambers. This view shows the apertures in the members.

Figure 5 is a schematic showing a valve configured with measuring sensors for switching from a waste line to a product collection line.

Figure 6 is a schematic showing the valve in-line with the waste line and the product collection line.

Figure 7 is a schematic showing another exemplary system for producing hypochlorous acid according to methods of the invention. This system is configured for automated use with buffered deionized water. The buffer can either be included in the inflowing water or can be introduced through an injection port. The buffer may also be mixed during the mixing process by using NaOH in NaOCl or separately injected and acetic acid or others similar acids or bases.

Figure 8 is a graph of a calibration curve showing HOCl concentration (ppm) calculated indirectly versus conductivity.

Figure 9 is a graph showing a spectrophotometric analysis of the produced HOCl. The gases generally produced during production of HOCl are ClO<sub>2</sub>, Cl<sub>2</sub>O and Cl<sub>2</sub>, all of which are detectable in the visible range as yellow or yellow-red. The graph shows no absorption from colored gases in the produced HOCl.

Figure 10 is a graph showing the amount (parts per million (ppm)) of HOCl initially produced (T = 0) and its stability over time.

Figure 11 is a graph showing how the pH of the HOCl product changed over time.

Figure 12 is a graph showing the oxidation and reduction (redox) of the HOCl product over time.

Figure 13 shows an anti-microbial composition that includes an aqueous solution of hypochlorous acid encapsulated in a nanoparticle.

Figure 14 is an illustration of a method of making an anti-microbial composition that includes an aqueous solution of hypochlorous acid encapsulated in a nanoparticle.

### Detailed Description

Treatment of bacterial infection and biofilm is achieved using a synergistic composition of acetic acid and hypochlorous acid. The acetic acid component is particularly effective for penetrating into tissues, while the hypochlorous acid is particularly effective for treating biofilm on the outer surface of tissue. Acetic acid can penetrate up to 2 mm or more beneath the surface of a wound to treat otherwise difficult to reach biofilms.

Compositions of the invention comprise hypochlorous acid in synergistic combination with acetic acid. It has been discovered that a balanced composition in which a biocidal amount of acetic acid (or an equivalent organic acid) optimized with hypochlorous acid achieves maximum therapeutic benefit, whether applied to a surface or in a manner designed to penetrate skin. For example, for surface applications, the relative amount of acetic acid to hypochlorous acid is lower than for penetrative applications. According to the invention, surface bacterial contamination or biofilm is sufficiently treated by hypochlorous acid with a lower amount of acetic acid; but for applications requiring deep penetration (e.g., wounds), the amount of acetic acid must be increased. In that case, hypochlorous acid is used to moderate the toxicity of the acetic acid to surrounding tissue, while allowing the acetic acid to attack the biofilm. In addition, it has been discovered that the synergistic combination of acetic acid and hypochlorous acid selectively kill harmful biofilm while preserving beneficial biofilm. Compositions of the invention comprise balanced concentrations of acetic acid and hypochlorous acid in order to selectively kill harmful biofilm. Concentrations are also balanced in consideration of the application to which they are directed (e.g., surface treatment of a tooth or skin versus deep tissue treatment of a wound or tooth root). The application provides guidance on the synergistic effects of various combinations of acetic acid and hypochlorous acid. The skilled artisan can determine, based upon the information provided in the instant specification, the relative amounts of acetic acid and hypochlorous acid necessary for treatment of any bacterial infection or biofilm formation.

Treating both the surface-level and subdermal infections provides a dual action treatment that is particularly needed for wound care. Chronic wounds and eczema are plagued by biofilm that affects subsurface parts of the wound. These wounds frequently have *S. aureus* infections which typically exist on or near the surface and prevent the wound from closing and healing.

Also, *P. aeruginosa* infection is often present, which is generally deeper, underneath the surface of the wound. When a deep infection is present, it is important to keep the wound open and hydrated while healing from the inside out, to prevent the wound from closing before the deeper infection is healed. Only treating the surface-level infection causes the wound to close and trap the deeper biofilm inside the tissue, which can lead to sepsis and other complications.

A frequent problem with diabetic foot ulcers, for example, is that they close at the surface, creating an open cavity beneath. The cavity will contain pus as part of the immune system response, which consists of debris, bacteria, and white blood cells. Pus contained in a closed compartment, particularly in a foot ulcer, can help spread the infection and potentially cause sepsis. In an open wound properly dressed, however, the pus will be discharged into the wound bed and the dressing. The bacteria that survive the pus environment inside a closed wound can spread infection. Therefore, removing the *S. aureus* infection without first or simultaneously removing the *P. aeruginosa* infection may not completely eradicate biofilm infection, leading to early closure and possibly sepsis.

Antimicrobial solutions, such as compositions provided herein, reduce infection in the deep areas of the wound bed and allow wound healing from the inside out, so that the surface does not heal faster than the inner wound. Acetic acid is present in an amount sufficient to disinfect a biofilm beneath the wound bed, and hypochlorous acid is present in an amount sufficient to disinfect the surface of the wound. The composition therefore allows complete disinfection of the wound to prevent premature closing and trapping a biofilm beneath the surface of a closed wound.

The disclosed compositions are particularly effective because balancing the concentrations of hypochlorous acid and acetic acid allows treatment of the surface level biofilm and also the sub-surface biofilm. The precise balance depends on the treatment site and the amount of surface penetration that is desired. The hypochlorous acid can be present in about 10 ppm up to about 500 ppm or more. Different uses and types of tissue may require higher or lower concentrations. The acetic acid may be present at about 0.25% up to about 2.0% or more, and preferably about 1.0%. By balancing the two components, the composition can have the dual effect of treating at the surface and beneath the surface of the tissue or wound.

Compositions consistent with the present disclosure can be created for a variety of uses. For example, a composition of relatively low acetic acid (as low as about 0.05%) and about 5-60

ppm of hypochlorous acid is a useful composition as a mouthwash for combating infection in dental tissue. The lower concentration of acetic acid is sufficient in mouthwash compositions because the microbial infection does not tend to penetrate deep within the tissue.

For wound treatment, on the other hand, a composition may include a higher concentration of acetic acid (about 1.0%, about 2.0%, about 3.0%, about 4.0%, or about 5.0%) to more effectively treat the biofilm deep inside the tissue.

Other uses may require more or less of each component. For example, a composition with hypochlorous acid concentration of about 80-250 ppm is useful for flushing a bladder, a treatment that is often needed for patients with a urinary catheter to prevent infection or blockage. A composition having a hypochlorous acid concentration of about 15-60 ppm is sufficient for treatment of an infected lung.

In certain embodiments, the composition is in the form of a gel, which allows longer contact times with the wound. Rinsing with a solution may not be sufficient, as the contact time of the antiseptic will be very short. In many cases, to fully remove a biofilm, the composition should be in contact with it for a prolonged period of time, ranging from a few seconds, to several minutes, to an hour or more. The composition may be provided in a gel or cream, which resists immediate evaporation or dispersal. Gels, creams, ointments, oils, and other similar carriers for topical administration are known in the art.

Additionally, for wound treatment, compositions in gel form have the benefit of maintaining moisture at the site of the wound. It is important to keep the wound hydrated during and after treatment with the compositions of the invention. The disclosed compositions are mostly water (generally 95% or more), allowing the wound to remain hydrated while the antiseptic ingredients of the composition fight infection in the wound and prevent new infections from taking hold. Maintaining hydration also prevents the wound from prematurely closing and trapping biofilm inside the tissue. Acetic acid is readily formulated in a gel because acetic acid is not overly reactive. Other organic acids can be used as well, and those that are less reactive are desirable.

Slow-release compositions may be used as well. In some compositions, acetic acid may be encapsulated in lipid soluble nanoparticles, which allow the acetic acid to be carried beneath the surface of a wound before being released from the nanoparticle. Administration with nanoparticles of different properties allows the acetic acid to be released slowly over time,

prevent dispersal, and provide other benefits to administration. Acetic acid is freely diffusing, water soluble, and has a high vapor pressure. These properties add to the difficulty of controlling where the acetic acid goes. Nanoparticle encapsulated acetic acid allows the composition to be more precisely controlled. Nanoparticles are described in greater detail below and shown in FIGS. 13 and 14.

In some embodiments, the composition includes some acetic acid that is free from nanoparticles and some acetic acid that is encapsulated within nanoparticles. Alternatively, slow-release formulations may be used on their own or in combination with other instant-acting formulations. For example, a wound may be treated with a composition of acetic acid and hypochlorous acid, and then treated with a composition of mainly acetic acid encapsulated in nanoparticles to provide ongoing release of acetic acid into the deep parts of the wound after the initial treatment.

#### Production of hypochlorous acid compositions

The basis of compositions and methods of the invention is the protonation of the hypochlorite ion (OCl<sup>-</sup>). Using HCl or acetic acid (HAc) and NaOCl as an example, the protonation is accomplished by introducing an acid (e.g., HCl) to the solution, which results in the following reaction occurring:

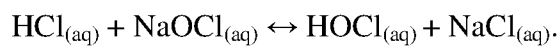

or

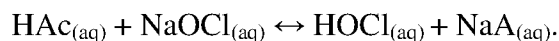

The hypochlorous acid in aqueous solution partially dissociates into the anion hypochlorite (OCl<sup>-</sup>), thus in aqueous solution there is always an equilibrium between the hypochlorous acid and the anion (OCl<sup>-</sup>). This equilibrium is pH dependent and at higher pH the anion dominates. In aqueous solution, hypochlorous acid, is also in equilibrium with other chlorine species, in particular chlorine gas, Cl<sub>2</sub>, and various chlorine oxides. At acidic pH, chlorine gases become increasingly dominant while at neutral pH the different equilibria result in a solution dominated by hypochlorous acid. Thus, it is important to control exposure to air and pH in the production of hypochlorous acid.

Additionally, the concentration of protons ( $H^+$ ) affects the stability of the product. The invention recognizes that the proton concentration can be controlled by using an acid that has a lesser ability at a given pH to donate a proton (i.e., the acid can provide buffering capacity). For example, conducting the process with acetic acid instead of hydrochloric acid is optimal when the desired pH of the final solution is approximately the pKa of acetic acid. This can be achieved by mixing ratios in water of 250X or greater, meaning 1 part proton donor at 100% concentration (e.g., HCl or acetic acid) to 250 parts water.

In certain embodiments, methods of manufacturing HOCl involve mixing together in water in an air-free environment, a compound that generates a proton ( $H^+$ ) in water and a compound that generates a hypochlorite anion ( $OCl^-$ ) in water to thereby produce air-free hypochlorous acid. The water may be tap water or purified water, such as water purchased from a water purification company, such as Millipore (Billerica, MA). Generally, the pH of the water is maintained from about 4.5 to about 9 during the method, however the pH may go above and below this range during the production process. Conducting methods of the invention in an air-free environment prevents the build-up of chlorine gases during the production process. Further, conducting methods of the invention in an air-free environment further stabilizes the produced HOCl.

Any compound that produces a hypochlorite anion ( $OCl^-$ ) in water may be used. Exemplary compounds include NaOCl and  $Ca(OCl)_2$ . In particular embodiments, the compound is NaOCl. Any compound that produces a proton ( $H^+$ ) in water may be used with methods of the invention. Exemplary compounds are acids, such as acetic acid, HCl and  $H_2SO_4$ . In particular embodiments, the compound is HCl. In preferred embodiments, the compound is acetic acid because it is a weaker acid with a preferred pKa to HCl, meaning, it donates fewer protons during the reaction than HCl and is able to maintain the preferred pH level better.

Mixing can be conducted in any type of vessel or chamber or fluidic system. In certain embodiments, a fluidic system **100** as shown in Figure 1 is used to perform methods of the invention. The system **100** includes a series of interconnected pipes **101a-c** with a plurality of mixing devices **102** and **103** in-line with the plurality of pipes **101a-c**. The pipes and the mixing devices can be interconnected using seals such that all air can be purged from the system, allowing for methods of the invention to be performed in an air-free environment. In certain embodiments, methods of the invention are also conducted under pressure. Making HOCl in an

air-free environment and under pressure allows for the production of HOCl that does not interact with gases in the air (e.g., oxygen) that may destabilize the produced HOCl.

Pipes **101a-c** generally have an inner diameter that ranges from about 5mm to about 50 mm, more preferably from about 17 mm to about 21 mm. In specific embodiments, the pipes **101a-c** have an inner diameter of about 21 mm. Pipes **101a-c** generally have a length from about 10 cm to about 400 cm, more preferably from about 15 cm to about 350 cm. In certain embodiments, pipes **101a-c** have the same length. In other embodiments, pipes **101a-c** have different lengths. In specific embodiments, pipe **101a** has a length of about 105 cm, pipe **101b** has a length of about 40 cm, and pipe **101c** has a length of about 200 cm.

The pipes and mixers can be made from any inert material such that material from the pipes and mixers does not become involved with the reaction occurring within the fluidic system. Exemplary materials include PVC-U. Pipes are commercially available from Georg Fischer AB. The pipes and mixers can be configured to have a linear arrangement such that the pipes and the mixers are arranged in a straight line. Alternatively, the pipes and mixers can have a non-linear arrangement, such that the water must flow through bends and curves throughout the process. System **100** shows a non-linear configuration of the pipes **101a-c** and mixers **102** and **103**.

Pipe **101a** is an inlet pipe that receives the water that will flow through the system. Generally, the water in pipes **101a-c** is under a pressure of at least about 0.1 bar, such as for example, 0.2 bar or greater, 0.3 bar or greater, 0.4 bar or greater, 0.5 bar or greater, 0.7 bar or greater, 0.9 bar or greater, 1.0 bar or greater, 1.2 bar or greater, 1.3 bar or greater, or 1.5 bar or greater. At such pressures, a turbulent water flow is produced, thus the reagents are introduced to a highly turbulent water flow which facilitates an initial mixing of the reagents with the water prior to further mixing in the mixing devices **102** and **103**.

In order to control the pH during the production process, the incoming water should have a buffering capacity in the range of pH 3.5-9.0, more preferably from 6.0 and 8.0, to facilitate addition of the compounds that generates the proton and the compound that generates the hypochlorite anion. The dissolved salts and other molecules found in most tap waters gives the tap water a buffering capacity in the range of pH 5.5-9.0, and thus tap water is a suitable water to be used with methods of the invention.

In certain embodiments, deionized water with the addition of known buffering agents to produce a water having a buffering capacity in the range of pH 3.5-9.0 is used. On example of a

buffer in this particular range is phosphate buffer. For greater process control and consistency, using a formulated deionized water may be preferable to using tap water because tap water can change between locations and also over time. Additionally, using deionized water with known additives also ensures a stable pH of the incoming water flow. This process is discussed in greater detail below.

In particular embodiments, an initial pH of the water prior to addition of either the compounds that generates the proton or the compound that generates the hypochlorite anion is at least about 8.0, including 8.1 or greater, 8.2 or greater, 8.3 or greater, 8.4 or greater, 8.5 or greater, 8.6 or greater, 8.7 or greater, 8.8 or greater, 8.9 or greater, 9.0 or greater, 9.5 or greater, 10.0 or greater, 10.5 or greater, or 10.8 or greater. In specific embodiments, the pH of the water prior to addition of either the compound that generates the proton or the compound that generates the hypochlorite anion is 8.4.

Methods of making HOCl include introducing to the water the compound that generates the proton and the compound that generates the hypochlorite anion in any order (e.g., simultaneously or sequentially) and in any manner (aqueous form, solid form, etc.). For example, the compound that generates the proton and the compound that generates the hypochlorite anion are each aqueous solutions and are introduced to the water sequentially, e.g., the compound that generates the proton may be introduced to the water first and the compound that generates the hypochlorite anion may be introduced to the water second.

System **100** is configured for sequential introduction of reagents to the water flow, and the process is described herein in which the compound that generates the proton is introduced to the water first and the compound that generates the hypochlorite anion is introduced to the water second. In certain embodiments, the compound that generates the proton and the compound that generates the hypochlorite anion are introduced to the water in small aliquots, e.g., from about 0.1 mL to about 0.6 mL. The iterative and minute titrations make it possible to control the pH in spite of additions of acid (compound that generates the proton) and alkali (the compound that generates the hypochlorite anion). In certain embodiments, no more than about 0.6 mL amount of compound that generates the proton is introduced to the water at a single point in time. In other embodiments, no more than about 0.6 mL amount of the compound that generates the hypochlorite anion is introduced to the water at a single point in time.

To introduce the reagents to the water, pipe **101a** includes an injection port **104** and pipe **101b** includes an injection port **105**. The injection ports **104** and **105** allow for the introduction of reagents to the water flow. In this embodiment, aqueous compound that generates the proton is introduced to the water in pipe **101a** via injection port **104**. The compound that generates the proton is introduced by an infusion pump that is sealably connected to port **104**. In this manner, the flow rate, and thus the amount, of compound that generates the proton introduced to the water at any given time is controlled. The infusion pump can be controlled automatically or manually. The rate of introduction of the compound that generates the proton to the water is based upon the incoming water quality (conductivity and pH level) and the pressure and the flow of the incoming water. In certain embodiments, the pump is configured to introduce about 6.5 liters per hour of hydrochloric acid into the water. The introducing can be a continuous infusion or in an intermittent manner. Since the water is flowing through the pipes in a turbulent manner, there is an initial mixing of the compound that generates the proton with the water upon introduction of the hydrochloric acid to the water.

Further mixing occurs when the water enters the first mixing device **102**. FIG. 2 shows a magnified view of the mixing device **102** shown in FIG. 1. In the illustrated embodiment, the mixing device includes a length of about 5.5 cm and a diameter of about 5 cm. One of skill in the art will recognize that these are exemplary dimensions and methods of the invention can be conducted with mixing devices having different dimensions than the exemplified dimensions. Mixing device **102** includes a fluidic inlet **106** that sealably couples to pipe **101a** and a fluidic outlet **107** that sealably couples to pipe **101b**. In this manner, water can enter the mixing chamber **108** of device **102** from pipe **101a** and exit the chamber **108** of device **102** through pipe **101b**.

The mixing device **102** is configured to produce a plurality of fluidic vortexes within the device. An exemplary device configured in such a manner is shown in FIG. 3, which is a figure providing an internal view of the chamber **108** of device **102**. The chamber **108** includes a plurality of members **109**, the members being spaced apart and fixed within the chamber **108** perpendicular to the inlet and the outlet in order to form a plurality of sub-chambers **110**. Each member **109** includes at least one aperture **111** that allows fluid to flow there through. FIG. 4 shows a front view of the members **109** so that apertures **111** can be seen. The size of the apertures will depend on the flow of water and the pressure in the system.

Any number of members **109** may be fixed in the chamber **108**, the number of members **109** fixed in the chamber **108** will depend on the amount of mixing desired. FIG. 4 shows four members **109a-d** that are fixed in the chamber to produce four sub-chambers **110a-d**. The members **109** may be spaced apart a uniform distance within the chamber **108**, producing sub-chambers **110** of uniform size. Alternatively, the members **109** may be spaced apart at different distances within the chamber **108**, producing sub-chambers **110** of different size. The members **109** are of a size such that they may be fixed to an interior wall within the chamber **108**. In this manner, water cannot flow around the members and can only pass through the apertures **111** in each member **109** to move through mixing device **102**. Generally, the members will have a diameter from about 1 cm to about 10 cm. In specific embodiments, the members have a diameter of about 3.5 cm.

A fluidic vortex is produced within each sub-chamber **110a-d**. The vortices result from flow of the water through the apertures **111** in each member **109**. Methods of the invention allow for any arrangement of the apertures **111** about each member **109**. FIG. 4 illustrates non-limiting examples of different arrangements of the apertures **111** within a member **109**. The apertures may be of any shape. FIG. 4 illustrates circular apertures **111**. In certain embodiments, all of the apertures **111** are located within the same place of the members **109**. In other embodiments, the apertures **111** are located within different places of the members **109**. Within a single member **109**, all of the apertures **111** may have the same diameter. Alternatively, within a single member **110**, at least two of the apertures **111** have different sizes. In other embodiments, all of the apertures **111** within a single member **110** have different sizes.

In certain embodiments, apertures **111** in a member **110** have a first size and apertures **111** in a different member **110** have a different second size. In other embodiments, apertures **111** in at least two different members **110** have the same size. The size of the apertures will depend on the flow of water and the pressure in the system. Exemplary aperture diameters are from about 1 mm to about 1 cm. In specific embodiments, the apertures have a diameter of about 6 mm.

The solution enters mixing device **102** through inlet **106**, which is sealably mated with pipe **101a**. The solution enters the chamber **108** and turbulent mixing occurs in each of sub-chambers **110a-d** as the solution pass through members **109a-d** via the apertures **111** in each

member **109a-d**. After mixing in the final sub-chamber **110d**, the water exits the chamber **108** via the fluidic outlet **107** which is sealably mated to pipe **101b**.

The compound that generates the hypochlorite anion is next introduced to the solution that is flowing through pipe **101b** via injection port **105**. The compound that generates the hypochlorite anion is introduced by an infusion pump that is sealably connected to port **105**. In this manner, the flow rate, and thus the amount, of compound that generates the hypochlorite anion introduced to the water at any given time is controlled. The infusion pump can be controlled automatically or manually. The rate of introduction of the compound that generates the hypochlorite anion to the water is based upon properties of the solution (conductivity and pH level) and the pressure and the flow of the solution. In certain embodiments, the pump is configured to introduce about 6.5 liters per hour of compound that generates the hypochlorite anion into the solution. The introducing can be a continuous infusion or in an intermittent manner. Since the solution is flowing through the pipes in a turbulent manner, there is an initial mixing of the compound that generates the hypochlorite anion with the solution upon introduction of the compound that generates the hypochlorite anion to the solution.

Further mixing occurs when the solution enters the second mixing device **103**. Mixing device **103** includes all of the features discussed above with respect to mixing device **102**. Mixing device **103** may be configured the same or differently than mixing device **102**, e.g., same or different number of sub-chambers, same or different diameter of apertures, same or different sizes of sub-chambers, etc. However, like mixing device **102**, mixing device **103** is configured to produce a fluidic vortex within each sub-chamber.

The solution enters mixing device **103** through an inlet in the device, which is sealably mated with pipe **101b**. The solution enters the mixing chamber and turbulent mixing occurs in each sub-chamber of the mixing device as the solution passes through members in the chamber via the apertures in each member. After mixing in the final sub-chamber, the water exits the chamber via the fluidic outlet in the mixing device which is sealably mated to pipe **101c**.

At this point, the reaction has been completed and the HOCl has been formed. The production is controlled in-line by measuring pH and conductivity. The pH is used in combination with conductivity based on a pre-calibrated relation between the conductivity and concentration of HOCl measured with spectrophotometry. The measured conductivity is a measure of the solvent's ability to conduct an electric current. Comparing the same matrix with

different known concentrations of HOCl and OCl<sup>-</sup>, a calibration curve (FIG. 8) has been established that is used in combination with the pH meter to regulate the titrations and control the process.

Pipe **101c** can be connected to a switch valve **112** that switches between a waste line **113** and a product collection line **114**. Shown in FIGS. 5 and 6. The valve **112** includes the pH meter and the conductivity measuring device. These devices measure the concentration (ppm), purity, and pH of the HOCl being produced and provide feedback for altering such properties of the produced HOCl. Once the HOCl being produced in pipe **101c** meets the required concentration, purity, and pH, the valve **112** switches from the waste line **113** to the product collection line **114** to collect the desired product.

The HOCl that has been produced in an air-free manner is collected and bottled in an air-free manner. Placing liquids into a bottle in an air-free manner is known in the art. An exemplary method includes placing an inflatable vessel (such as a balloon) into a bottle. The inflatable vessel is connected directly to the collection line **114** and the HOCl is pumped directed into the inflatable vessel in the bottle without ever being exposed to air. Another method involves filling the bottles under vacuum. Another air-free filling method involves filling the bottles in an environment of an inert gas that does not interact with the HOCl, such as an argon environment.

The produced hypochlorous acid is air-free and will have a pH from about 4.5 to about 7.5. However, the pH of the produced HOCl can be adjusted post production process by adding either acid (e.g., HCl) or alkali (e.g., NaOCl) to the produced hypochlorous acid. For example, a pH of between about 4.5 and about 7 is particularly suitable for the application of reprocessing heat sensitive medical instruments. Other applications, such as its use in non-medical environments, for example as in the processing of poultry and fish and general agricultural and petrochemical uses, the breaking down of bacterial biofilm and water treatment, may demand different pH levels.

The process can be performed manually or in an automated manner. Fluidic systems described herein can be operably connected to a computer that controls the production process. The computer may be a PCL-logic controller system. The computer opens and closes the valves for the water inlet, the waste water outlet, and the product outlet according to the feedback received from the sensors in the system (e.g., conductivity, pH, and concentration of product (ppm) being produced). The computer can also store the values for the water pressures and water

amounts and can adjust these according to the feedback received from the sensors regarding the properties of the HOCl being produced. The computer can also control the infusion pumps that inject the reagents into the water for the production process.

The process can be performed iteratively in that pipe **101c** can be attached to a second fluidic system and the produced HOCl is then flowed through the second system where the process described above is repeated with the starting solution being HOCl instead of water. In this manner, an increased yield of HOCl is produced. Any number of fluidic systems may be interconnected with methods of the invention.

FIG. 7 is a schematic showing another exemplary system **200** for producing hypochlorous acid according to methods of the invention. System **200** is configured for regulation of the pH of the incoming water and injecting buffer for stability. In system **200**, water is introduced into pipe **201a**. Pipe **201a** has a pH meter **208** connected to it. pH meter **208** measures the pH of the incoming water. The pH meter **208** is connected to injection port **202**. The injection port **202** allows for the introduction of at least one buffering agent to the incoming water. The buffering agent is introduced by an infusion pump that is sealably connected to port **202**. In this manner, the flow rate, and thus the amount, of buffering agent introduced to the water at any given time is controlled. The infusion pump can be controlled automatically or manually. The rate of introduction of the buffering agent to the water is based upon the incoming water quality (conductivity and pH level), the buffer composition, and the pressure and the flow of the incoming water. The introducing can be a continuous infusion or in an intermittent manner. Since the water is flowing through the pipe **201a** in a turbulent manner, there is an initial mixing of the buffering agent with the water upon introduction of the buffering to the water. This initial mixing may be sufficient to properly adjust the properties of the incoming water.

In certain embodiments, further mixing of the water and buffer is performed prior to conducting the process of producing the HOCl. In those embodiments, further mixing occurs when the water with buffering agent enters the first mixing device **203**. Mixing device **203** includes all of the features discussed above with respect to mixing device **102**. Mixing device **203** may be configured the same or differently than mixing device **102**, e.g., same or different number of sub-chambers, same or different diameter of apertures, same or different sizes of sub-

chambers, etc. However, like mixing device **102**, mixing device **203** is configured to produce a fluidic vortex within each sub-chamber.

The solution enters mixing device **203** through an inlet in the device, which is sealably mated with pipe **201a**. The solution enters the mixing chamber and turbulent mixing occurs in each sub-chambers of the mixing device as the solution pass through members in the chamber via the apertures in each member. After mixing in the final sub-chamber, the water exits the chamber via the fluidic outlet in the mixing device which is sealably mated to pipe **202b**. The water has a pH of at least about 8.0, preferably 8.4, and a buffering capacity of pH 5.5-9.0.

The process is now conducted as described above for producing HOCl. The compound that generates the proton is next introduced to the water that is flowing through pipe **201b** via injection port **204**. The compound that generates the proton is introduced by an infusion pump that is sealably connected to port **204**. In this manner, the flow rate, and thus the amount, of compound that generates the proton introduced to the water at any given time is controlled. The infusion pump can be controlled automatically or manually. The rate of introduction of the compound that generates the proton to the water is based upon properties of the water (conductivity and pH level), the buffer composition, and the pressure and the flow of the water. In certain embodiments, the pump is configured to introduce from about 6.5 liters per hour to about 12 liters per hour of compound that generates the proton into the water. The introducing can be a continuous infusion or in an intermittent manner. Since the water is flowing though the pipes in a turbulent manner, there is an initial mixing of the compound that generates the proton with the water upon introduction of the hydrochloric acid to the water.

Further mixing occurs when the solution enters the second mixing device **205**. Mixing device **205** includes all of the features discussed above with respect to mixing device **102**. Mixing device **205** may be configured the same or differently than mixing device **203**, e.g., same or different number of sub-chambers, same or different diameter of apertures, same or different sizes of sub-chambers, etc. However, like mixing device **203**, mixing device **205** is configured to produce a fluidic vortex within each sub-chamber.

The solution enters mixing device **205** through an inlet in the device, which is sealably mated with pipe **201b**. The solution enters the mixing chamber and turbulent mixing occurs in each sub-chambers of the mixing device as the solution pass through members in the chamber

via the apertures in each member. After mixing in the final sub-chamber, the water exits the chamber via the fluidic outlet in the mixing device which is sealably mated to pipe **201c**.

The compound that generates the hypochlorite anion is next introduced to the solution that is flowing through pipe **201c** via injection port **206**. The compound that generates the hypochlorite anion is introduced by an infusion pump that is sealably connected to port **206**. In this manner, the flow rate, and thus the amount, of compound that generates the hypochlorite anion introduced to the water at any given time is controlled. The infusion pump can be controlled automatically or manually. The rate of introduction of the compound that generates the hypochlorite anion to the water is based upon properties of the solution (conductivity and pH level) and the pressure and the flow of the solution. In certain embodiments, the pump is configured to introduce about 6.5-12 liters per hour of compound that generates the hypochlorite anion into the solution. The amount introduced depends on the desired concentration of HOCl (ppm) and flow of water through the pipes. The introducing can be a continuous infusion or in an intermittent manner. Since the solution is flowing through the pipes in a turbulent manner, there is an initial mixing of the compound that generates the hypochlorite anion with the solution upon introduction of the compound that generates the hypochlorite anion to the solution.

Further mixing occurs when the solution enters the second mixing device **207**. Mixing device **207** includes all of the features discussed above with respect to mixing device **102**. Mixing device **207** may be configured the same or differently than mixing devices **205** or **203**, e.g., same or different number of sub-chambers, same or different diameter of apertures, same or different sizes of sub-chambers, etc. However, like mixing devices **205** and **203**, mixing device **207** is configured to produce a fluidic vortex within each sub-chamber.

The solution enters mixing device **207** through an inlet in the device, which is sealably mated with pipe **201c**. The solution enters the mixing chamber and turbulent mixing occurs in each sub-chambers of the mixing device as the solution pass through members in the chamber via the apertures in each member. After mixing in the final sub-chamber, the water exits the chamber via the fluidic outlet in the mixing device which is sealably mated to pipe **201d**.

At this point, the reaction has been completed and the HOCl has been formed. The produced HOCl can be measured and collected as described above. Pipe **201d** can be connected to a switch valve that switches between a waste line and a product collection line. The valve includes a pH meter and a conductivity measuring device. These devices measure the

concentration, purity, and pH of the HOCl being produced and provide feedback for altering such properties of the produced HOCl. Once the HOCl being produced in pipe **201d** meets the required concentration, purity, and pH, the valve switches from the waste line to the product collection line to collect the desired product.

In another embodiment, a deionizer is placed in-line with incoming water. The deionizer deionizes the water and then a buffering agent is added to the deionized water. The production process is then conducted as described for embodiments of system **200** to produce water having a pH of at least about 8, for example 8.4, and a buffering capacity of pH 6-8.

The HOCl produced by the above process can be used in numerous different applications, for example medical, foodservice, food retail, agricultural, wound care, laboratory, hospitality, dental, delignification, or floral industries.

#### Wound care

In certain embodiments, compositions of the invention are used for wound care. Wound care involves treating damaged or broken skin, including abrasions, lacerations, ruptures, punctures, or burns. Particular wound care treatments involve treating biofilms. Biofilms may form when free floating microorganisms such as bacteria and fungus attach themselves to a surface. Biofilms are known to impair cutaneous wound healing and reduce topical antibacterial efficiency in healing or treating infected wounds. Other common health conditions related to biofilms include urinary tract infections, middle-ear infections, chronic wounds, and the formation of dental plaque. Cystic fibrosis, native valve endocarditis, otitis media, periodontitis, and chronic prostatitis also involve microorganisms that produce biofilms. Microorganisms commonly associated with biofilms include *Candida albicans*, coagulase-negative *staphylococci*, *Enterococcus*, *Klebsiella pneumoniae*, *Pseudomonas aeruginosa*, *Staphylococcus aureus*, and others.

Biofilms are often resistant to traditional antimicrobial treatments, and are therefore a serious health risk. The resistance of biofilms renders traditional antibiotic and antimicrobial treatments ineffective. Because biofilms can greatly reduce susceptibility to antibiotics and disinfectants, treatments are needed that are capable of breaking down biofilms but that are not too toxic to the patient.

Methods are provided for administration of a composition to an individual in need of treatment for a biofilm-associated infection. Methods of the invention include prophylaxis, therapy, or cure of a biofilm-associated infection. Methods include administration of one or more unit doses of a composition in a therapeutically or prophylactically effective amount for treatment of an existing biofilm-associated infection or prevention of establishment of a biofilm-associated infection in the individual. In some embodiments, spread of a biofilm-associated infection to another site in the individual is inhibited. In various embodiments, the composition may be administered parenterally, orally, locally, or topically. Compositions may be applied by intravenous, intra-muscular, or subcutaneous injection. In methods of the invention, compositions may be administered in a pharmaceutically acceptable carrier, examples of which are discussed below.

Treatment includes killing of microbes inhabiting the biofilm or removing a biofilm, inhibiting biofilm formation, and disrupting an existing biofilm. The compositions disclosed herein are particularly effective for treatment of microbial biofilms in or on a wound. The composition may be in the form of a topically administrable wound treatment composition which comprises a hypochlorous acid and acetic acid compound. The composition may be combined with an additional antimicrobial agent.

Compositions of the invention can be administered topically to a subject, e.g., by the direct laying on or spreading of the composition on the epidermal or epithelial tissue of the subject. The composition may be formulated as a liquid, powder, lotion, cream, gel, oil, ointment, gel, solid, semi-solid formulation, or aerosol spray. Such formulations may be produced in a conventional manner using appropriate carriers which are well known to a person skilled in the art.

Suitable carriers for topical administration preferably remain in place on the skin as a continuous film, and resist being removed by perspiration or immersion in water. The carrier may include pharmaceutically-acceptable emollients, emulsifiers, thickening agents, solvents, and the like.

The composition may be provided as part of a wound dressing in which the composition is provided within the wound dressing or on the wound-contacting surface thereof. A wound dressing may be intended to be applied to a wound to be treated and which comprises a substrate comprising compositions in accordance with the invention. Such a dressing is particularly

convenient because it delivers the composition of the invention to the wound to be treated and simultaneously provides a dressing therefor. The wound dressing may, for example, be fibrous, a foam, a hydrocolloid, a collagen, a film, a sheet hydrogel or a combination thereof. The wound dressing may be in the form of a layered dressing in which one or more layers of the dressing are formed at least in part or one or of; natural fibers, alginate, Chitosan, Chitosan derivatives, cellulose, carboxymethyl-cellulose, cotton, Rayon, Nylon, acrylic, polyester, polyurethane foam, hydrogels, hydrocolloids, polyvinyl alcohol, starch, a starch film, collagen, hylaronic acid and its derivatives, biodegradable materials, and other materials known in the art. Methods of the invention may further comprise negative-pressure wound therapy, as is known in the art. Such therapies involve applying negative pressure to the wound, such as with a vacuum dressing.

The composition may be administered in a single daily dose or in multiple doses, e.g., 2, 3, 4, or more doses, per day. The total daily amount of composition may be about 0.01 mg, 0.1 mg, 1 mg, 2 mg, etc., up to about 1000 mg. In some embodiments, the total daily amount of administered is about 0.01 mg to about 1 mg, about 1 mg to about 10 mg, about 10 mg to about 100 mg, about 100 mg to about 500 mg, or about 500 mg to about 1000 mg. The actual dosage may vary depending upon the specific composition administered, the mode of administration, the type or location of biofilm to be treated, and other factors known in the art. In some embodiments a dosage can also be selected so as to provide a predetermined amount of composition per kilogram of patient weight.

The use of the compound in conjunction with another known antimicrobial treatment may increase the efficacy of the antimicrobial agent. In some embodiments, methods of the invention further comprise administration (simultaneously or sequentially with compositions of the invention) of one or more doses of an antibiotic substance, including, but not limited to, ciproflaxin, ampicillin, azithromycin, cephalosporin, doxycycline, fusidic acid, gentamycin, linezolid, levofloxacin, norfloxacin, ofloxacin, rifampin, tetracycline, tobramycin, vancomycin, amikacin, deftazidime, cefepime, trimethoprim/sulfamethoxazole, piperacillin/tazobactam, aztreanam, meropenem, colistin, or chloramphenicol. In some embodiments, methods of the invention further comprise administration of one or more doses of an antibiotic substance from an antibiotic class including, but not limited to, aminoglycosides, carbacephem, carbapenems, first generation cephalosporins, second generatin cephalosporins, third generation cephalosporins, fourth generation cephalosporins, glycopeptides, macrolides, monobactam,

penicillins, polypeptides, quinolones, sulfonamides, tetracyclines, lincosamides, and oxazolidinones. In some embodiments, methods of the invention comprise administration of a nonantibiotic antimicrobial substance, including but not limited to sertraline, racemic and stereoisomeric forms of thioridazine, benzoyl peroxide, taurolidine, and hexitidine.

#### Treating biofilm on other tissues

Compositions of the invention can be used to treat biofilms affecting various parts of the body, or attached to various surfaces. In some embodiments, methods of the invention comprise administration of a therapeutically effective composition to an individual in need thereof for treatment of a biofilm-associated infection in the bladder, kidney, heart, middle ear, sinuses, skin, lung, a joint, subcutaneous tissue, soft tissue, vascular tissue, and/or the eye. In other embodiments, a therapeutically effective amount of composition is administered to an individual in need thereof for treatment of one or more of the following conditions associated with biofilm: urinary tract infection; chronic bacterial vaginosis; prostatitis; bacterial infection stemming from diabetes, such as a diabetic skin ulcer; pressure ulcer; venous catheter-associated ulcer; or a surgical wound (e.g., a surgical site infection). In some embodiments, the biofilm is on the skin of an individual. In some embodiments, the biofilm is associated with a wound, including abrasions, lacerations, ruptures, punctures, burns, and chronic wounds. In some embodiments, the biofilm is below the surface of the skin, in subcutaneous tissue, such as a deep tissue wound or a surgical site infection.

#### Treating biofilm on non-tissue surfaces

Other applications for treating biofilms are also envisaged. For example, the composition of the invention has application for the treatment of microbial biofilms on surfaces, e.g. surfaces in hospitals (such as operating rooms or patient care rooms) as well as other surfaces (e.g., household work surfaces). The invention also encompasses treating biofilms that form on implanted medical devices and prosthetics.

As is known in the art, implanted medical devices are susceptible to biofilm formation, including fungal biofilms and bacterial biofilms. Methods and compositions of the invention can also be used to treat biofilms that form on the surfaces of implanted medical devices such as catheters and prosthetics. Compositions of the invention can be applied to a medical device pre-

implantation. Alternatively, the medical device can comprise a reservoir containing the composition, such that the composition can be released in a controlled manner after implantation. Methods for treating implanted medical devices can be found in U.S. Patents 5,902,283 and 6,589,591, and U.S. Patent Publication 2005/0267543, each of which is incorporated by reference herein in its entirety.

### Dental treatment

In another embodiment of the invention, a method is provided for treating an orally-associated biofilm such as dental plaque. The invention provides methods for oral plaque prevention, treating oral plaque infection, treating tooth hypersensitivity, sterilizing a root canal, or treating a dental disease.

Methods of the invention comprise contacting an oral surface, such as teeth, gums, gingiva, or tongue, with a therapeutically effective amount of the composition. Some methods of the invention comprise prevention of an orally-associated biofilm by administration of a prophylactically effective amount of composition to an individual. The composition may be formulated as a dentifrice, such as toothpaste, for treatment or prevention of dental plaque. In other embodiments, the biofilm may be located on the tongue, oral mucosa, or gums. In some embodiments, the composition is formulated as a mouthwash. In some embodiments, the composition is formulated as a paint, foam, gel, or varnish, for example, in a fluoride-containing composition. In an embodiment, the composition is in the form of a gel or foam in a mouthguard that a patient wears for several minutes for fluoride treatment. In other embodiments the composition is contacted to an adhesive strips, which can be applied to the teeth or other oral surface. The composition may comprise a liquid polymer formulation, which is a composition that is preferably topically applied to a surface such as a tooth, to skin, to a mucous membrane, and which dries as a film adhering to that surface, in a manner which resists removal under normal conditions, such as eating or brushing, for applications to the teeth and oral mucosa, or normal washing and abrasion, when applied to skin. Alternatively, the composition may be applied to bandages, dressings, gauze, brushes, implants, etc. and permitted to dry into a film in advance of its administration to a patient.

### Mastitis treatment

In another embodiment of the invention, compositions and methods are provided for treating mastitis. Mastitis is an inflammation tissue in the breast or udder of a mammal. It is often associated with bacterial infections such as *Pseudomonas aeruginosa*, *Staphylococcus aureus*, *Staphylococcus epidermidis*, *Streptococcus agalactiae*, *Streptococcus uberis*, and others. Some of the bacteria known to cause mastitis also form biofilms, but not all mastitis results from biofilm formation.

Mastitis can occur in any mammal, such as humans, cows (dairy cattle), and other animals. Mastitis is a particular problem for dairy cattle. In cattle the condition occurs when leukocytes are released into the mammary gland, often as a response to bacteria in the teat canal. Cows that are repeatedly infected often must be culled to prevent widespread infection in the herd. The loss of milk from infected cows and the loss of cows and entire herds due to infection results in large economic losses for the dairy industry worldwide. In the United States, for example, mastitis is estimated to cost the dairy industry up to \$2 billion each year.

Methods are provided for administration of a composition to a mammal in need of treatment for mastitis. Methods of the invention include prophylaxis, therapy, or cure for mastitis. In some embodiments, spread of mastitis to another quarter or to another animal is inhibited.

The formulations, dosages, and routes of administration discussed above are applicable to these embodiments of the invention. For example, in various embodiments, the composition may be administered parenterally, orally, locally, or topically. Compositions may be applied by intravenous, intra-muscular, or subcutaneous injection. Compositions may be applied by infusion via a teat canal, as is known in the art. In methods of the invention, compositions may be administered in a pharmaceutically acceptable carrier, which may include emollients, emulsifiers, thickening agents, solvents, and the like.

The composition may be administered in a single daily dose or in multiple doses, e.g., 2, 3, 4, or more doses, per day. The total daily amount of composition may be about 0.01 mg, 0.1 mg, 1 mg, 2 mg, etc., up to about 1000 mg. In some embodiments, the total daily amount of administered is about 0.01 mg to about 1 mg, about 1 mg to about 10 mg, about 10 mg to about 100 mg, about 100 mg to about 500 mg, or about 500 mg to about 1000 mg. The actual dosage may vary depending upon the specific composition administered, the mode of administration,

and other factors known in the art. The composition may be administered in conjunction with another known antimicrobial treatment such as an antibiotic.

Compositions can be administered topically to a cow's udder by directly applying or spreading the composition onto the udder or teat. The composition may be formulated as a liquid, powder, lotion, cream, gel, oil, ointment, gel, solid, semi-solid formulation, or aerosol spray. Methods of the invention may further comprise dipping a teat into the composition. Teat dipping can be used to treat an already infected udder or to prophylactically prevent mastitis from developing. The composition may be applied immediately before milking, immediately after milking, or both. Methods of teat dipping are known in the art, and are described in more detail in U.S. Patent 4,113,854, as well as U.S. Patent Publications 2003/0235560 and 2003/0113384, each of which is incorporated by reference herein in its entirety. Methods may further comprise use of a teat sealant to create a physical barrier for the teat orifice after administration of the composition.

In other embodiments, compositions can be provided via intramammary infusion. Intramammary infusion involves forcing the antibiotic up through the teat canal into the udder. Infusion liquid may comprise a composition disclosed herein in combination with a pharmaceutically acceptable carrier such as canola oil. Prior to infusion, the teat is cleaned, for example with an alcohol swab. An antibiotic infusing device may include a cannula sized and shaped to fit into the teat canal. The cannula may be fully or partially inserted through the streak canal. Methods for infusion are known in the art and are described, for example, in U.S. Patents 4,983,634 and 5,797,872, the entirety of each of which is incorporated by reference herein.

Methods of the invention may further comprise administering antibiotics in conjunction with compositions of the invention, or in sequential doses before or after administration of the compositions.

#### Wounds and surgical uses

The compositions can be applied to prevent and treat biofilm on other types of living tissue as well. Tissue includes, for example, skin, mucus membranes, wounds, or ostomies. As has been described above, the composition is useful for wound treatment. Wounds include bedsores, chronic wounds, burns, pressure wounds, diabetes wounds, and other forms of skin trauma. Wounds are often susceptible to biofilm formation, which prevents healing and can lead

to chronic conditions. Hypochlorous acid and acetic acid compositions can be used for debridement and cleaning of damaged tissue.

The compositions can also be used in a surgical setting, for treating skin prior to or after an operation. The composition prevents infection that would lead to biofilm formation. At times, an area requiring surgery such as a traumatic wound may already be at risk of having developed a biofilm. The hypochlorous acid composition can be used to disinfect the area prior to surgical incision, which would not only help treat the biofilm but also lessen the likelihood of it spreading to other tissue during surgery. The compositions may be used to disinfect any surface within a surgical operating field.

#### Other medical uses

In addition to wound care, HOCl compositions of the invention can also be used for non-traumatic tissue treatment. They may be used for bladder irrigation, for preventing or treating bladder infections or catheter-associated urinary tract infections, and the like. They may be similarly used to treat infections in the aerodigestive tract such as sinus and lung infections, or infections in the oral cavity, pharynx, paranasal sinuses, sinonasal tract, larynx, pyriform sinus, or esophagus. They can be used to fight microbial growth that leads to infection and to reduce allergens that cause adverse immune responses. The compositions may also be administered to the gastrointestinal tract, including the stomach, intestines, and colon, to combat microbial infections such as gastroenteritis, *Clostridium difficile* infection, and small-intestine bacterial overgrowth (SIBO).

In various other embodiments, the compositions can be administered in the form of eye drops to fight eye infections, or can be used to clean or store contact lenses to prevent bacterial growth and biofilm formation. In other embodiments, the composition can be used as an oral rinse or mouthwash to fight biofilm buildup in the oral cavity, or it can be used to clean or store dentures.

In addition to the use as an antiseptic to treat or prevent biofilms on living tissue, the compositions can be used as a disinfectant on other surfaces such as for use in healthcare facilities, food preparation, cooking utensils, and the like. Compositions can be used to disinfect countertops, hospital beds, or food preparation surfaces.

The compositions can be used to disinfect medical devices and surgical instruments, for example. Medical devices are often initially supplied as sterile, but may require additional or subsequent cleaning and disinfection or sterilization. Reusable medical devices in particular must be sterilized or disinfected prior to reuse. Compositions can be applied to the medical device using any known technique. For example, the composition can be applied by wiping or spreading it onto the surface of the device, by spraying an aerosol or mist form of the composition onto the device, by dipping the device into a vessel containing a volume of the composition, or by placing the device into a flow of the composition such as from a faucet. Additionally or alternatively, medical devices and surgical instruments may also be stored submerged in the composition and removed at the time of use.

Treatment with a hypochlorous acid composition disclosed herein can be done in addition to other known techniques such as autoclaving. Alternatively, the composition can be applied instead of autoclaving. Because heat sterilization is not useful for all devices (e.g., some devices contain delicate parts or electronics that cannot withstand high temperatures), hypochlorous acid compositions are a useful alternative, providing an effective way to sterilize or disinfect such devices.

The compositions can also be used to disinfect implants and prostheses before introducing them to the body. Such devices include orthopedic implants, wires, screws, rods, artificial discs, prosthetic joints, soft tissue fillers, pacemakers, intra-uterine devices, coronary stents, ear tubes, artificial lenses, dental implants, and many others known in the art.

The stabilized hypochlorous acid and acetic acid compositions described herein are useful for both biofilm prevention and biofilm removal on all of the surfaces and tissues discussed herein. Because biofilms make microbes far more resistant to traditional antimicrobial agents, microbes that form biofilms are more able to share and modify their resistance genes and spread into the air and surroundings. As a consequence of biofilm development, a simple infection may become chronic, antibiotics and antiseptics stop working, and new strains of infections emerge.

Both acetic acid (or other organic acids) and hypochlorous acid, however, are particularly useful for treating and preventing biofilms. The HOCl compositions disclosed herein mimic the natural disinfectant of the immune system. Therefore the compositions are not susceptible to microbial resistance. Additionally, they are non-toxic, do not sting, and relieve itching.

The various embodiments and uses described above involve a variety of methods of administration, as would be understood in the art.

Hypochlorous acid compositions are particularly effective for transdermal treatment due to the small size of the HOCl molecule. Hypochlorous acid is able to penetrate epithelium and wound surfaces, and so can generally reach deeper tissue layers without requiring injection. This is particularly useful for biofilm infection that forms beneath the top layer of skin. Unlike many other antimicrobial treatments, acetic acid and similar organic acids can penetrate deeper layers of skin without requiring an invasive delivery mechanism.

In some embodiments, however, it may be desirable to prevent the HOCl from penetrating into the skin, and therefore the compositions can be combined with excipients, carriers, emulsifiers, polymers, or other ingredients, examples of which are discussed in U.S. Patent Application 2016/0271171, which is incorporated herein by reference in its entirety.

In addition to topical use, wherein the compositions can be sprayed, wiped, or rubbed onto skin, in other embodiments the compositions may be injected into a particular tissue requiring treatment. The compositions can be ingested in capsule form for administration to the gastrointestinal tract. They can be supplied in slow-release or delayed-release capsules. The compositions can be provided as a suppository for insertion into the rectum or vagina.

In other embodiments, the compositions can be provided as a nasal spray for treatment of the aerodigestive tract, which can include treatment of allergic reactions, sinus infections and the like. The nasal spray may be in droplet, aerosol, gel, or powder form. The buffered hypochlorous acid and acetic acid composition can be combined with one or more of a decongestant or an anti-inflammatory or anti-histamine agent, as needed. The composition can be aerosolized with a nasal spray dispenser as is known in the art.

The nasal spray may also include a pharmaceutically acceptable carrier, such as a diluent, to facilitate delivery to the nasal mucosa. The carrier might be an aqueous carrier such as saline. The composition may be isotonic, having the same osmotic pressure as blood and lacrimal fluid. Suitable non-toxic pharmaceutically acceptable carriers are known to those skilled in the art. Various carriers may be particularly suited to different formulations of the composition, for example whether it is to be used as drops or as a spray, a nasal suspension, a nasal ointment, a nasal gel or another nasal form. Other additives, excipients, emulsifiers, dispersing agents, buffering agents, preservatives, wetting agents, consistency aids, and gelling agents may be

included as well. Preferably, additives should be chosen that impart the desired characteristic without reducing the stability of the hypochlorous acid. Additives may aid in evenly administering the composition over the mucosa or for reducing or delaying the rate of absorption of the composition.

The composition can be delivered by various devices known in the art for administering drops, droplets, and sprays. The nasal spray composition can be delivered by a dropper, pipet, or dispensing. Fine droplets, sprays, and aerosols can be delivered by an intranasal pump dispenser or squeeze bottle. The composition can also be inhaled via a metered dose inhaler, such as a dry powder inhaler or a nebulizer.

#### Controlled Release with Nanoparticle Encapsulation

Stable aqueous solutions of hypochlorous acid and/or acetic acid can be encapsulated in nanoparticles that allow controlled release of the acid from the nanoparticles. Controlled release allows persistent anti-microbial protection.

FIG. 13 shows an anti-microbial composition 1301 comprising an aqueous solution 1303 of hypochlorous acid encapsulated in a nanoparticle 1305. The aqueous solution 1303 of hypochlorous acid is made by a method described herein to produce a solution in which the acid is stable. The stable hypochlorous acid solution 1303 is then encapsulated in nanoparticle 1305. The nanoparticle allows gradual release of the hypochlorous acid. Although not depicted, acetic acid can also be encapsulated in a nanoparticle for controlled release.

The nanoparticle may be any type of nanoparticle that provides controlled release of the acid from the nanoparticle. The nanoparticle may comprise a polymer, such as an organic polymer. Examples of polymers suitable for controlled-release nanoparticles include acrylic acid, carrageenan, cellulosic polymers (e.g., ethyl cellulose or hydroxypropyl cellulose), chitosan, cyclodextrins, gelatin, guar gum, high amylose starch, hyaluronic acid, locust bean gum, pectin, polyacrylamide, poly(D,L-lactide-co-glycolide acid), poly(lactic acid), poly(xylitol adipate salicylate), polyanhydride, poly(ethylene oxide), poly(ethyleneimine), polyglycerol ester of a fatty acid, polysaccharides, polyvinyl alcohol, povidone, sodium alginate, and xanthan gum. For details on the use of polymers to form controlled-release nanoparticles, see Binnebose, et al., *PLOS Negl Trop Dis* 9:e0004713 (2015); Campos, et al., *Scientific Reports* 5:13809 (2015); Dasgupta et al., *Mol. Pharmaceutics* 12:3479-3489; Gao, et al., *The Journal of Antibiotics*

64:625–634, (2011); Lee, et al., *International Journal of Nanomedicine* 11:285-297 (2016); and U.S. Patent No. 8,449,916 (incorporated by reference). The nanoparticle may contain an aluminosilicate (such as a zeolite, e.g., analcime, chabazite, clinoptilolite, heulandite, leucite, montmorillonite, natrolite, phillipsite, or stilbite), calcium ammonium nitrate, hydroxyapatite (e.g., urea-modified hydroxyapatite), metal hydroxide, metal oxide, polyphosphate, or silicon compound (e.g., silicon dioxide). The nanoparticle may contain lipids, i.e., it may be a lipid nanoparticle. The nanoparticle may include a liposome. For details on the use of liposomes to form controlled-release nanoparticles, see Weiniger et al., *Anaesthesia* 67:906–916 (2012). The liposome may be multi-lamellar. The nanoparticle may contain a gel, sol-gel, emulsion, colloid, or hydrogel. For details on the use of hydrogels to form controlled-release nanoparticles, see Grijalvo et al., *Biomater. Sci.* 4:555 (2016). The nanoparticle may contain a combination of formats, such as a hydrogel encapsulated within a liposome. The nanoparticle may have a core-shell structure. The nanoparticle may be biodegradable. Compositions of the invention may include an anti-metabolic agent. The anti-metabolic agent may be a metal ion. For example, the anti-metabolic agent may be zinc, copper, or silver.

A nanoparticle that allows controlled release of hypochlorous acid or acetic acid permits diffusion of the acid to occur more slowly than the acid would diffuse from an equal volume of the same aqueous solution of the acid that is not encapsulated in a nanoparticle. The controlled release of hypochlorous acid or acetic acid may be due to permeability characteristics of the nanoparticle, e.g., a nanoparticle that is partially or poorly permeable to the acid. A controlled-release nanoparticle may be a nanoparticle that releases the acid due to degradation of the nanoparticle or impairment of its structural integrity in a time-dependent manner. Release of the acid from the nanoparticle may be triggered by environmental conditions, such as pH, temperature, light, pressure, redox conditions, or the presence of a particular chemical.

FIG. 14 is an illustration of a method 1401 of making an anti-microbial composition that includes an aqueous solution 1403 of hypochlorous acid encapsulated in a nanoparticle 1405. The method entails mixing 1411 in water in a chamber 1413 from which air has been purged a compound 1415 that generates a proton ( $H^+$ ) in water and a compound 1417 that generates a hypochlorite anion ( $OCl^-$ ) in water. The mixing 1411 produces an air-free aqueous solution 1403 of hypochlorous acid. The solution 1403 is then encapsulated 1421 in a nanoparticle 1405. The

encapsulation may be performed in an air-free environment to produce a composition that is substantially free of air.

*Compositions for aerodigestive treatment*

The invention provides compositions and methods for treating and/or regulating the aerodigestive tract with compositions comprising hypochlorous acid. According to the invention, hypochlorous acid compositions made as described herein are safe and effective for the treatment of aerodigestive infections and/or regulation of the gut biome.

Compositions including hypochlorous acid and acetic acid can be provided as a nasal spray for treatment of the aerodigestive tract. The nasal spray may be in droplet, aerosol, gel, or powder form. The buffered hypochlorous acid and acetic acid composition can be combined with one or more of a decongestant or an anti-inflammatory or anti-histamine agent, as needed. The composition can be aerosolized with a nasal spray dispenser as is known in the art.

The nasal spray may also include a pharmaceutically acceptable carrier, such as a diluent, to facilitate delivery to the nasal mucosa. The carrier might be an aqueous carrier such as saline. The composition may be isotonic, having the same osmotic pressure as blood and lacrimal fluid. Suitable non-toxic pharmaceutically acceptable carriers are known to those skilled in the art. Various carriers may be particularly suited to different formulations of the composition, for example whether it is to be used as drops or as a spray, a nasal suspension, a nasal ointment, a nasal gel or another nasal form. Other additives, excipients, emulsifiers, dispersing agents, buffering agents, preservatives, wetting agents, consistency aids, and gelling agents may be included as well. Preferably, additives should be chosen that impart the desired characteristic without reducing the stability of the hypochlorous acid. Additives may aid in evenly administering the composition over the mucosa or for reducing or delaying the rate of absorption of the composition.

Compositions for use according to the invention are produced as described herein and are formulated for delivery to all or a portion of the aerodigestive tract. For example, hypochlorous acid can be formulated in an aerosol for intranasal delivery as described herein. Intranasal delivery can be a vehicle for addressing the entirety of the aerodigestive tract, but is primarily used to treat infections in the nose, the sinuses, the lungs, and the upper GI tract. In other examples, hypochlorous acid is formulated for oral delivery. Compositions of the invention are

prepared in an appropriate diluent or adjuvant for pharmaceutical deliver (e.g, oral dosing) or are formulated as part of a fluid that is delivered as a beverage. According to the invention, hypochlorous acid compositions can be formulated as a hydration drink (e.g., a sports drink), a milkshake, an electrolyte balance drink, a smoothie and the like. Compositions of the invention can also be integrated into food, such as a yogurt. In addition, compositions of the invention can be formulated for deliver directly to the aerodigestive tract through, for example, a suppository, an enema or direct application during surgery.

Compositions of the invention can be formulated along with other components. For example, hypochlorous acid compositions can be combined with antibiotics, antivirals, probiotics, and other medicaments or nutraceuticals. Thus, compositions of the invention are useful for both the regulation of the aerodigestive tract and for the treatment of infections in the aerodigestive tract.

The composition can be delivered by various devices known in the art for administering drops, droplets, and sprays. The nasal spray composition can be delivered by a dropper, pipet, or dispensing. Fine droplets, sprays, and aerosols can be delivered by an intranasal pump dispenser or squeeze bottle. The composition can also be inhaled via a metered dose inhaler, such as a dry powder inhaler or a nebulizer.

#### *Compositions of acetic acid and hypochlorous acid for biofilm treatment*

The disclosed formulations of acetic acid and hypochlorous acid are superior for treating biofilms on surfaces including skin or other tissue. The compositions use a balanced formula where the combination of acetic acid and hypochlorous acid provide greater disinfecting qualities than either substance alone. In fact the present invention recognizes that the particular disclosed combinations provide greater disinfecting power than would be expected by adding the acetic acid and hypochlorous acid. In other words, the compositions have been found to be greater than the sum of their parts. These benefits are shown in the accompanying data in FIGS. 15-21, which demonstrate how the balanced compositions of acetic acid and hypochlorous acid provide enhanced disinfecting capabilities against biofilms and outperform all other products on the market. The differences in performance are shown across a wide range of concentrations.

Additionally, since acetic acid is toxic at high concentrations, the prior art has taught away from its use on skin or other tissue, except in trace amounts. Some of the disclosed

compositions contain acetic acid at 2% or greater, and when in combination with HOCl have proven to be safe and effective for treating skin and other tissues. The HOCl in these compositions has been found to have a modulating effect of the acetic acid. This allows the compositions to take advantage of the antimicrobial properties of acetic acid without causing harm to the tissue. Additionally, HOCl has an analgesic function, so it also allows higher concentrations of HAc to be used on skin or other tissue without causing excessive pain or discomfort to the patient.

FIG. 15 for example, shows a comparison of various concentrations of HOCl and acetic acid against other commercially available antimicrobial compositions. Eight different treatments were tested, as listed along the x-axis. Each composition was exposed to a 24-hour filter-grown *S. aureus* biofilm, and the reduction in biofilm was measured in colony-forming units per milliliter (cfu/ml) and reported on a log scale along the y-axis. Measurements of the reduction in biofilm were recorded at 3 hours and 6 hours. Each column therefore has two bars, and shows the effect of each composition on the biofilm over time.

The first three columns show the results of 200ppm HOCl with three different concentrations of acetic acid (0.25%, 1.0%, and 2.0%, respectively). The fourth column shows 1% acetic acid alone. The next four columns show commercially available antimicrobial products: Prontosan; Octenilin; Pyrisept; and Microdacyn, which is a hypochlorous acid composition.

The results show that all three combinations of acetic acid and hypochlorous acid were more effective against the biofilm than any of the other compositions. At 3 hours, test composition A (200ppm HOCl and 0.25% HAc) performed approximately as well as the Prontosan, the current market leader in biofilm treatment. It also far outperformed the 1% HAc or the other commercially available products. After 6 hours, however, composition A showed much greater efficacy than even Protosan.

Meanwhile, test composition B (200ppm HOCl and 1.0% HAc) was even more effective at treating biofilm. Comparing composition B with the 1% HAc (in the fourth column) shows the unexpected benefit of the addition of HOCl. Despite having the same concentration of acetic acid, composition B far outperforms the 1% HAc alone at both 3 hours and 6 hours.

Composition C (200ppm HOCl and 2.0% HAc) showed by far the greatest reduction in biofilm among the tested compositions. At both 3 and 6 hours, it was several orders of magnitude more effective than the commercially available products.

These data show that in addition to being more effective in reducing biofilm than any of the commercially available products, the compositions containing both acetic acid and hypochlorous acid were more effective than acetic acid alone (1% HAc) or hypochlorous acid alone (microdacyn), and those superior results cannot be explained merely by the additive effect of the two components. Without being bound by any particular mechanism, the data show that the acetic acid and hypochlorous acid combination provides a synergistic effect that allows the composition to be more effective than would otherwise be predicted based on the efficacy of each component alone.

FIGS. 16-19 show the effects of various compositions of HOCl and HAc on *P. aeruginosa* biofilms. FIG. 16 shows a comparison of compositions having 1% acetic acid and varying concentrations of HOCl. Five different treatments were tested with HOCl in concentrations of 0ppm, 50ppm, 100ppm, 150ppm, and 200ppm. Each composition was exposed to a 24-hour filter-grown *P. aeruginosa* biofilm, and the reduction in biofilm was measured in colony-forming units per milliliter (cfu/ml) and reported on a log scale along the y-axis. Measurements of the reduction in biofilm were recorded at 2 hours and 4 hours.

As shown in the graph, the reduction at 2 hours was greater with higher concentrations of HOCl, with a particularly significant spike at 150ppm. At 4 hours, the spike occurs at even lower concentrations of HOCl.

FIG. 17 shows the effects on *P. aeruginosa* of different compositions where the concentration of HOCl is maintained at 100ppm and the percentage of acetic acid varies from 0.25% to 2%. FIG. 18 shows the effects as both HOCl and HAc increase.

FIGS. 19-21 show different compositions of HOCl and HAc against *S. aureus* and *P. aeruginosa* under various conditions. The figures show the superior results obtained with combinations of hypochlorous acid and acetic acid, which demonstrate the synergistic effect of those two compounds.

The various disclosed formulations may be effective for treating biofilm infections in different types of tissue. For example, the 200ppm HOCl and 0.25% HAc composition is useful for topical applications such as hand disinfection or mouth wash. This composition is more

effective than other commercially available products at treating surface-level biofilms as shown in FIG. 15. For treating penetrating deeper into tissue, or for clearing particularly bad biofilm infections or invasive biofilms that have penetrated beneath the surface, a higher percentage of HAc may be used, such as the formulation of 200ppm HOCl with 2% HAc. This composition is useful for treating infected wounds, preventing biofilm in wounds, treating eczema, or treating other infections. This formulation has been found to be effective for combatting biofilms that have formed in the root of teeth.

FIGS. 20-21 show additional data supporting the unexpected efficacy of acetic acid and hypochlorous acid compositions on various biofilms, particularly as compared to prior art and commercially available compositions. As the figures make clear, various compositions that balance in the concentrations of HOCl and HAc in different ways provide an assortment of disinfecting compositions that can target different types of biofilms on different types of tissue.

Another benefit of the disclosed HOCl and HAc compositions is that while they are particularly effective at reducing pathogenic biofilms, they have been found not to inhibit growth of “good” biofilms and other microbes that live symbiotically on and in tissue. In some trials, the good biofilm was reduced to a lesser extent than the pathogenic biofilm, and it grew back faster than the target biofilm did. Especially compared with alcohol-based disinfectants, the disclosed compositions were more effective at targeting the pathogenic biofilm infection without damaging the good microbes. The disclosed compositions therefore are a targeted treatment, combating biofilm infections without causing harm to the body’s natural flora.

#### Incorporation by Reference

Any and all references and citations to other documents, such as patents, patent applications, patent publications, journals, books, papers, web contents, that have been made throughout this disclosure are hereby incorporated herein by reference in their entirety for all purposes.

#### Equivalents

The invention may be embodied in other specific forms without departing from the spirit or essential characteristics thereof. The foregoing embodiments are therefore to be considered in all respects illustrative rather than limiting on the invention described herein.

### Examples

#### Example 1: Product analysis

When spectrophotometry is expanded to also cover the visible range it is possible to detect colors. The gases generally produced during production of HOCl are ClO<sub>2</sub>, Cl<sub>2</sub>O and Cl<sub>2</sub>, all of which are detectable in the visible range as yellow or yellow-red. Tzanavaras et al. (Central European J. of Chemistry, 2007, 5(1)1-12). Data in FIG. 9 illustrates that the HOCl produced by methods on the invention shows no absorption from colored gases as shown by the lack of colored substance. It is known that HOCl produces a peak at 292 nm (Feng et al. 2007, J. Environ. Eng. Sci. 6, 277-284).

#### Example 2:

HOCl produced by the process described above was stored under heat stress at 40°C in order to accelerate degradation using four different types of aqueous solutions: (1) reagent grade water (deionized water); (2) tap water; (3) reagent grade water with a phosphate buffer; and (4) tap water with a phosphate buffer. Characteristics of the HOCl product were monitored after the initial reaction (T = 0); four weeks (T = 4); eight weeks (T = 8); and twelve weeks (T = 12).

FIG. 10 is a graph showing the amount (parts per million (ppm)) of HOCl initially produced (T = 0) and its stability over time. The data show that the reagent grade water (deionized water) without phosphate buffer is the most stable over the twelve weeks, showing the least amount of product degradation from the initial amount produced. The deionized water produces a much more stable product than that produced using tap water. Additionally, and surprisingly, the data show that phosphate buffer may negatively impact amount of HOCl product produced.

FIG. 11 is a graph showing how the pH of the HOCl product changed over time. In all cases, the pH decreased over time, however, for all cases, the pH stayed in the range of pH = 4 to pH = 7 over the twelve weeks.

FIG. 12 is a graph showing the oxidation capacity of the HOCl product over time. The data show that the product retained oxidation capacity over the twelve weeks regardless of the starting water.

Example 3: Acetic acid compared to hydrochloric acid

Using the above described process, HOCl was produced using hydrochloric acid (HCl) and acetic acid and thereafter stored under heat stress at 40C. The amount of HOCl initially produced was recorded (T = 0) and then the amount of HOCl product remaining after twelve days was recorded. Three batches of each were produced. The data for the HCl produced HOCl is shown in Table 1. The data for the acetic acid produced HOCl is shown in Table 2.

Table 1: HOCl produced with HCl

Batch number	Initial amount (ppm)	Initial pH	Amount after 12 days (ppm)	pH after 12 days	Amount of degradation	Amount pH change
1	192	7.12	159	5.71	17.2%	19.8%
2	183	5.88	147	4.01	19.7%	31.8%
3	189	5.21	154	3.97	18.5%	23.8%

Table 2: HOCl produced with acetic acid

Batch number	Initial amount (ppm)	Initial pH	Amount after 12 days (ppm)	pH after 12 days	Amount of degradation	Amount pH change
1	205	4.62	180	4.50	12.4%	2.7%
2	205	5.33	178	5.04	13.3%	5.4%
3	207	4.07	178	3.89	13.9%	4.6%

The data show that using acetic acid provides greater product stability, most likely due to greater stability in the pH. Without being limited by any particular theory or mechanism of action, it is believed that the different protonation capacity of acetic acid as compared to hydrochloric acid, i.e., acetic acid donates fewer protons to a liquid than hydrochloric acid, results in greater HOCl stability over time.

Claims

What is claimed is:

1. An air-free antimicrobial composition comprising acetic acid and hypochlorous acid having a balanced concentration of each so as to achieve a synergistic effect resulting in the composition being sufficient to treat a bacterial biofilm without harming surrounding skin, wherein at least some of the acetic acid is encapsulated in a nanoparticle, and wherein the acetic acid has a concentration of approximately 2.0 wt % and the hypochlorous acid has a concentration of approximately 200 ppm.
2. The composition of claim 1, wherein the acetic acid is present in a concentration sufficient to treat a biofilm on the skin.
3. The composition of claim 1 or claim 2, wherein the composition is formulated in a gel, cream, ointment, or oil.

**WIAB Water Innovation AB**  
**Patent Attorneys for the Applicant/Nominated Person**  
**SPRUSON & FERGUSON**

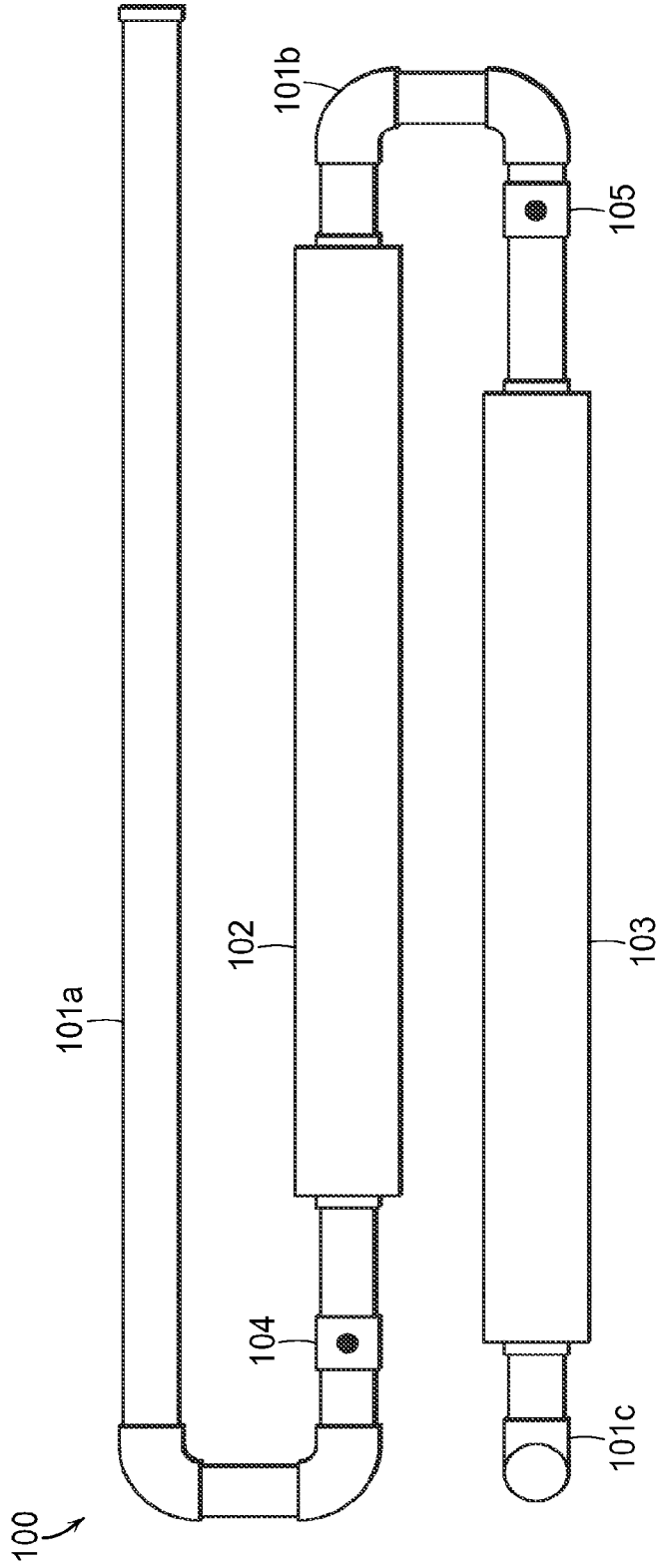

FIG. 1

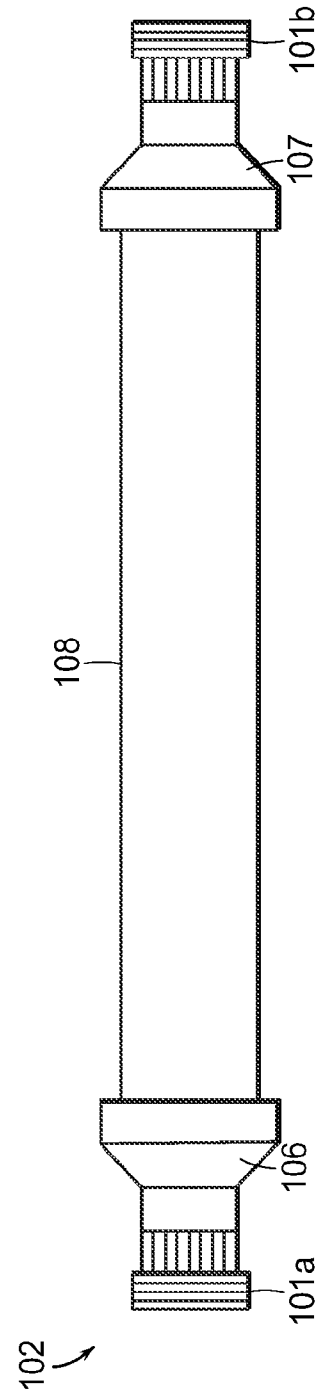

FIG. 2

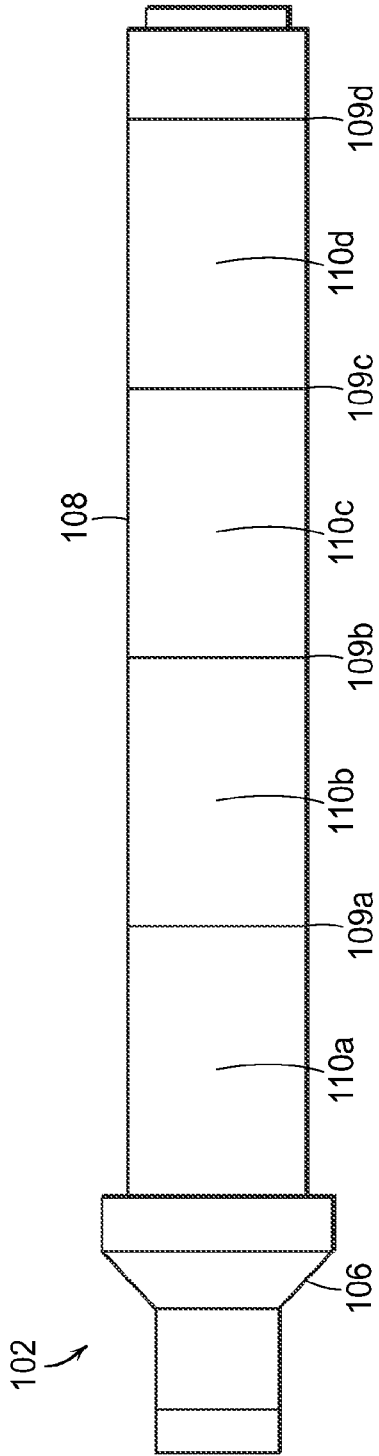

FIG. 3

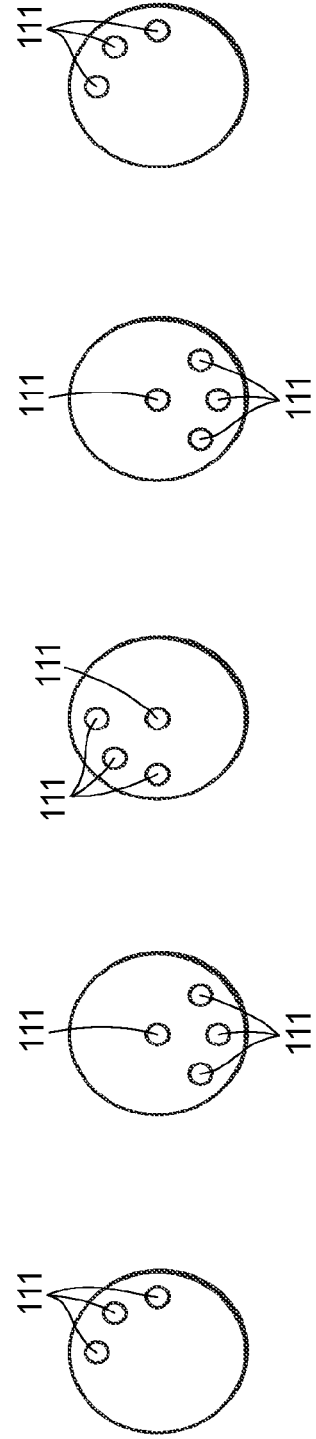

FIG. 4

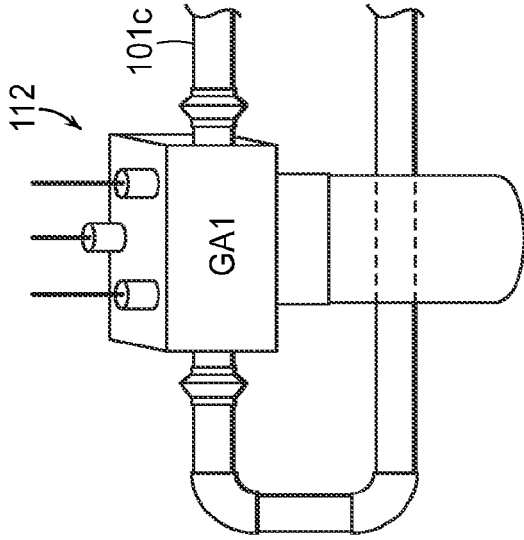

FIG. 5

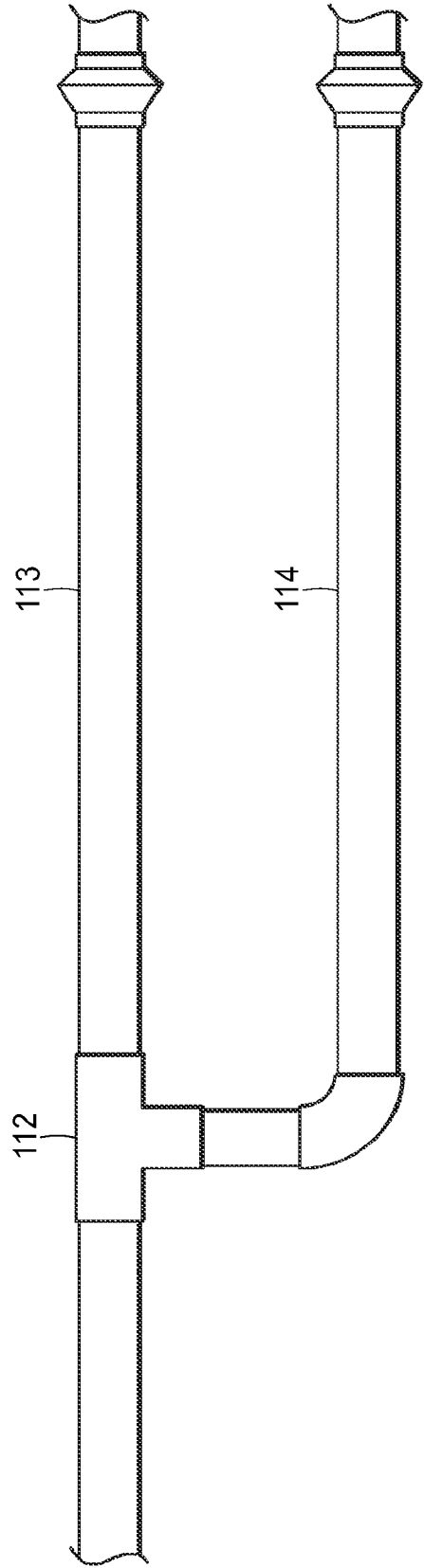

FIG. 6

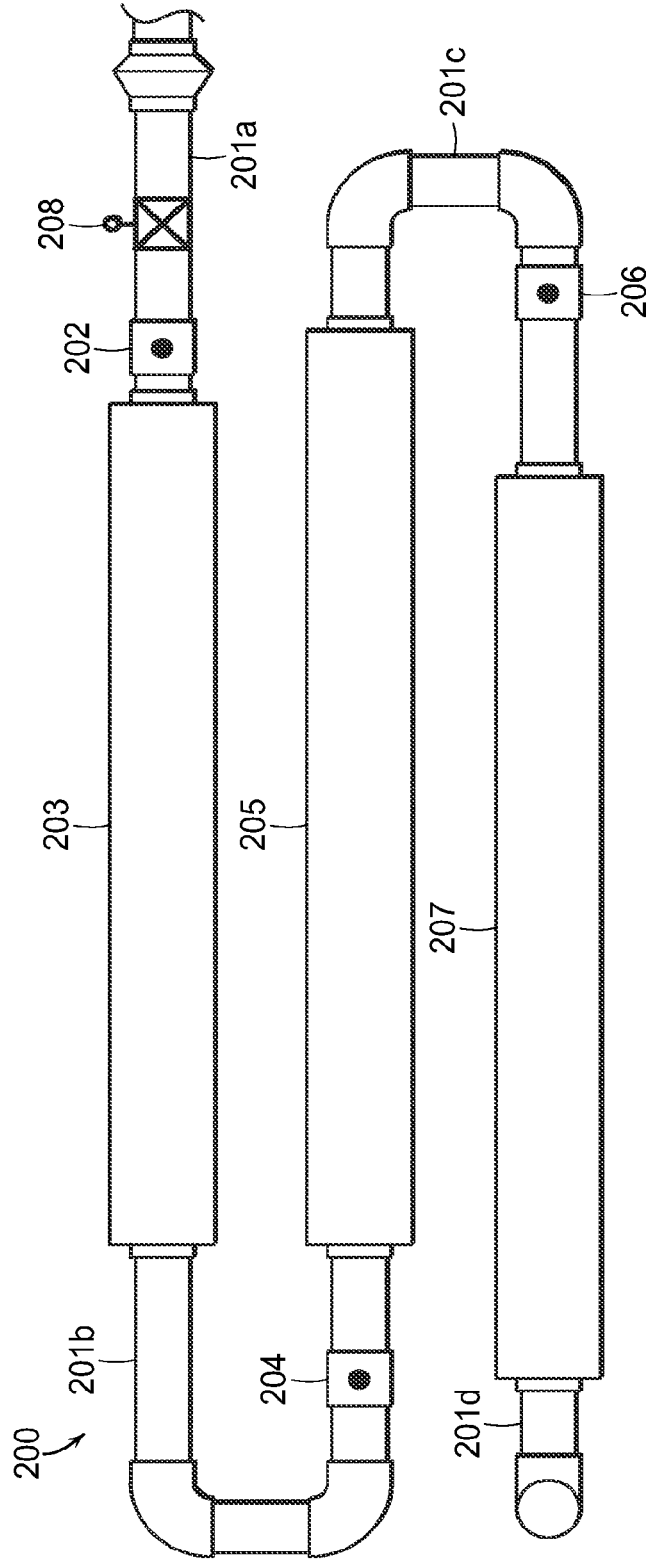

FIG. 7

2017380595 25 Jun 2019

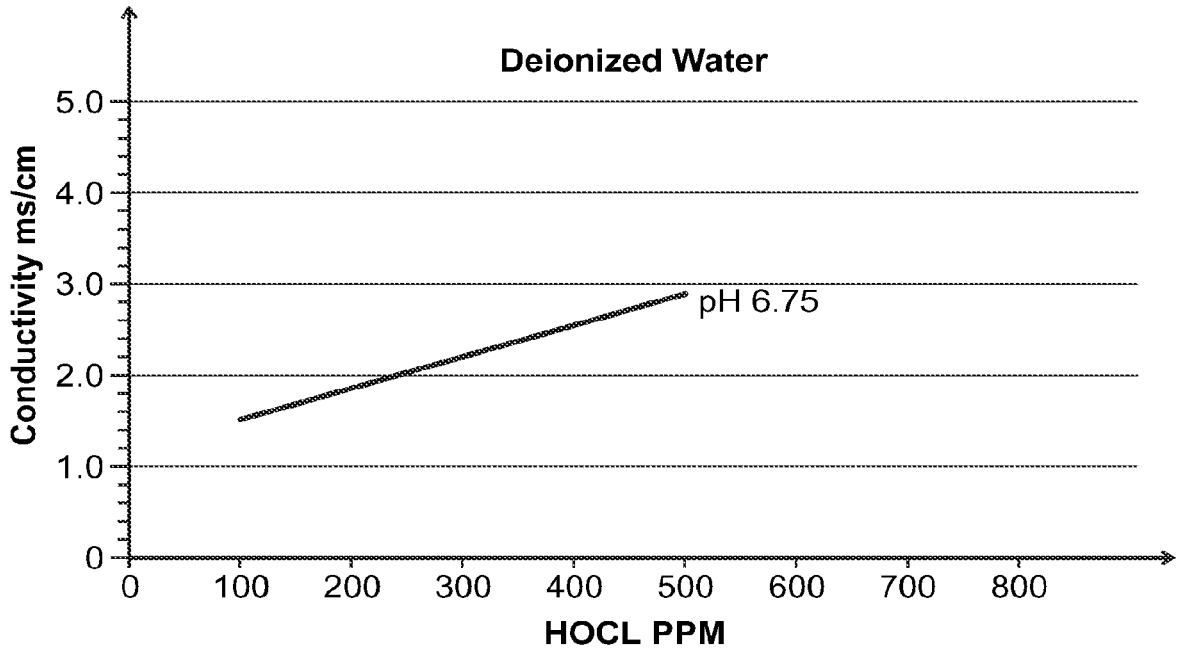

FIG. 8

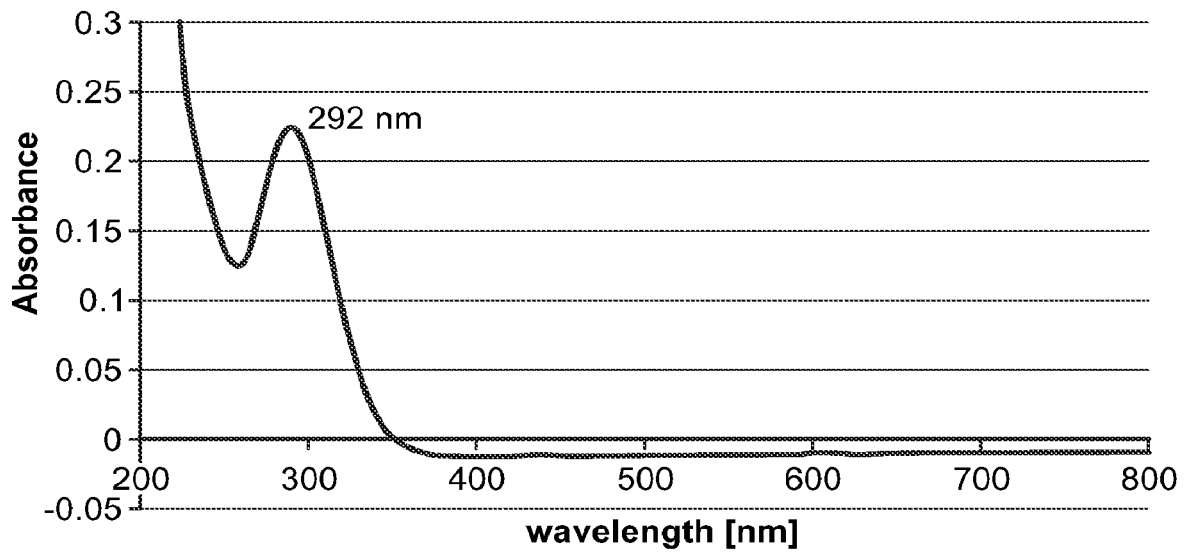

FIG. 9

2017380595 25 Jun 2019

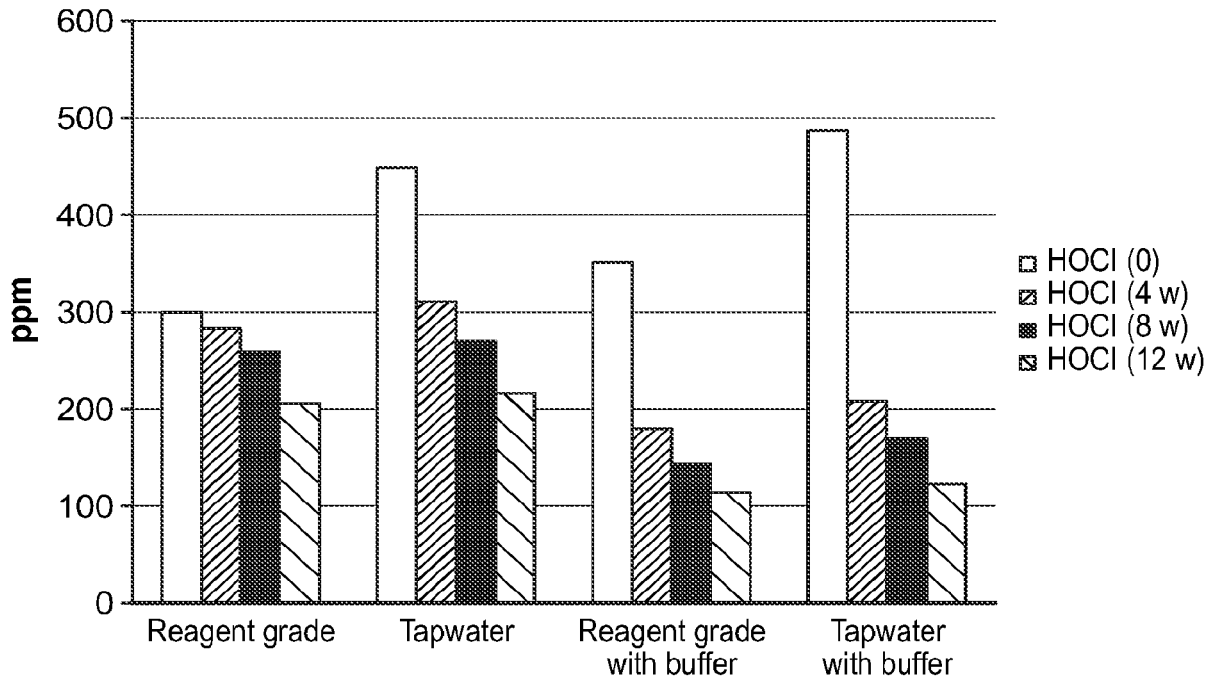

FIG. 10

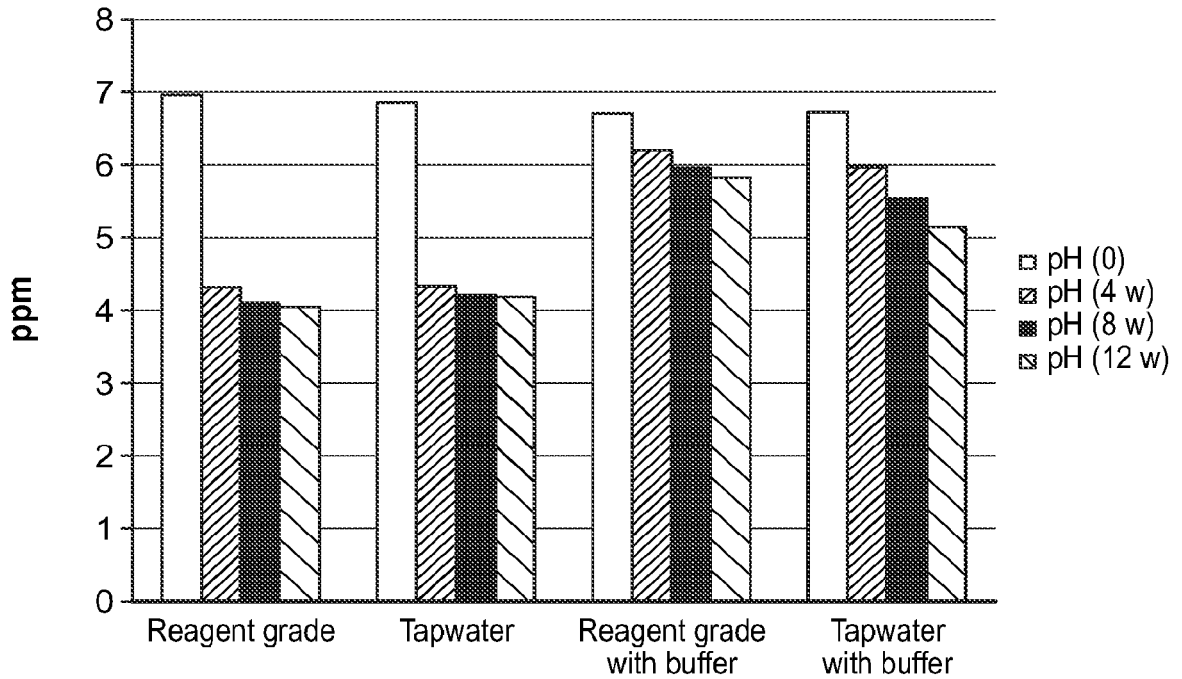

FIG. 11

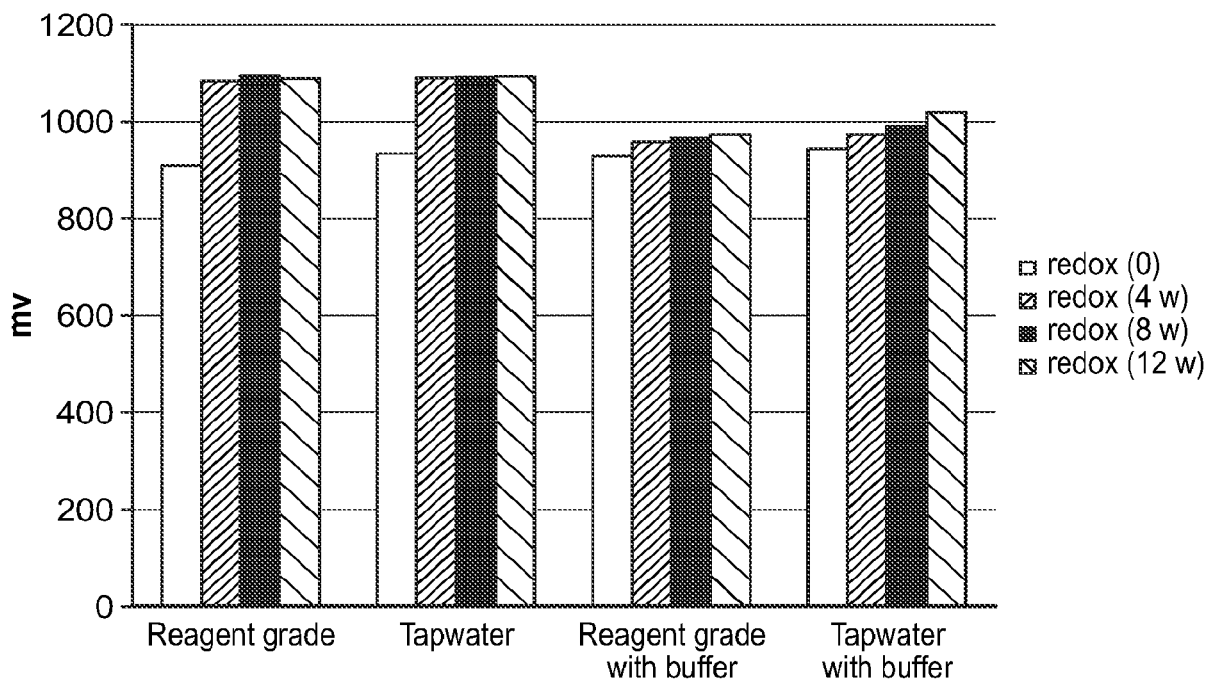

FIG. 12

2017380595 25 Jun 2019

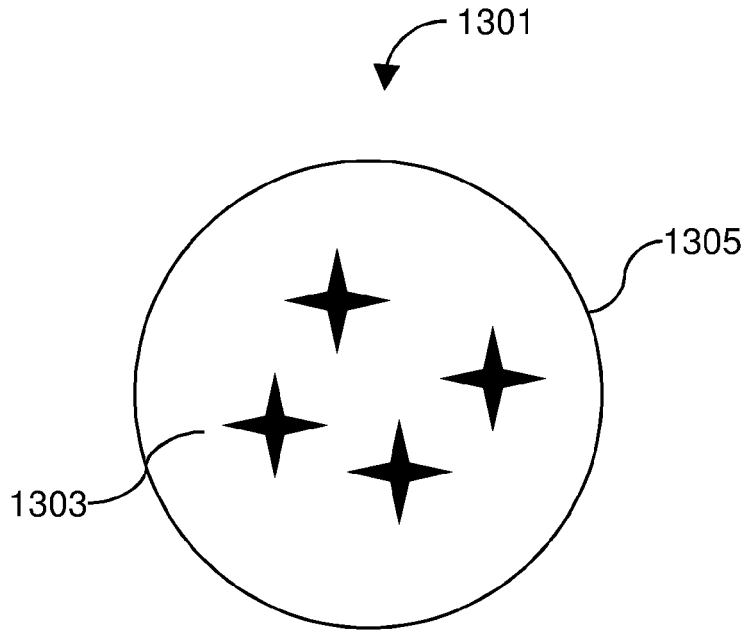

FIG. 13



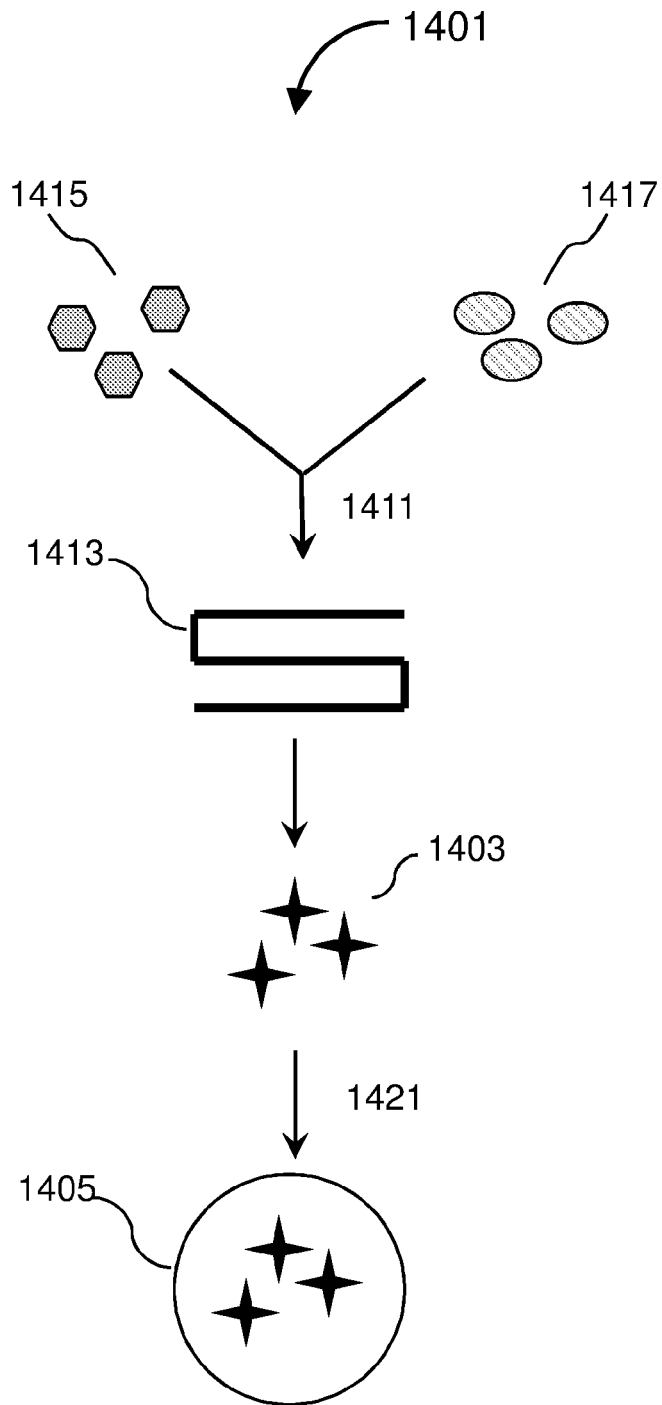

FIG. 14

2017380595 25 Jun 2019