

J. S. BRENNAN,
 OIL BURNER.
 APPLICATION FILED MAY 5, 1919.

1,317,153.

Patented Sept. 30, 1919.
 2 SHEETS—SHEET 1.

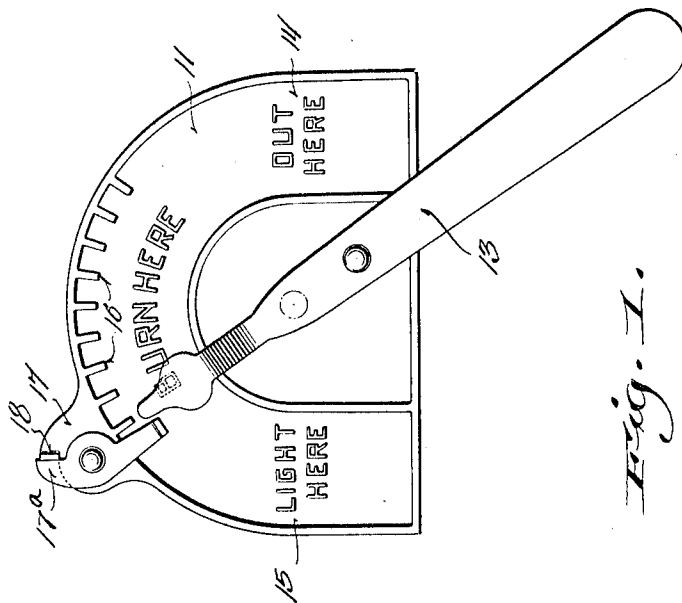
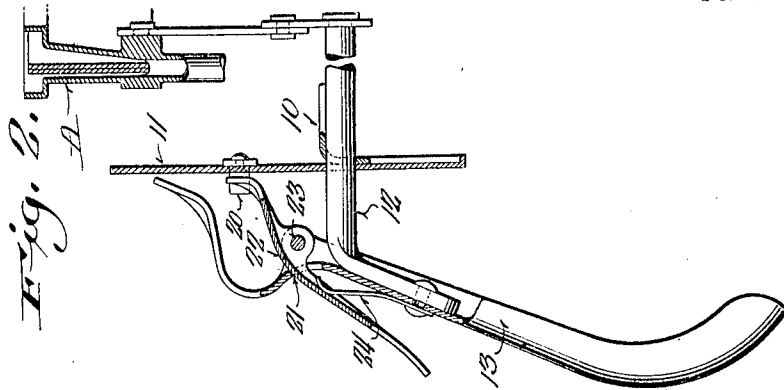

Witness:
William C. Young

Inventor:
 John S. Brennan

By *Young & Young*
 Attorneys

J. S. BRENNAN.
 OIL BURNER.
 APPLICATION FILED MAY 5, 1919.

1,317,153.

Patented Sept. 30, 1919.
 2 SHEETS—SHEET 2.

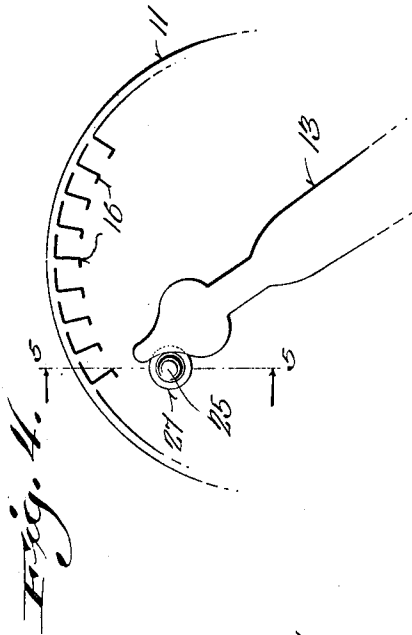

Fig. 4.

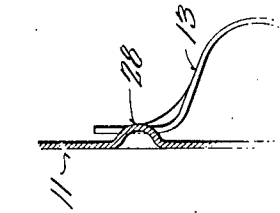

Fig. 5.

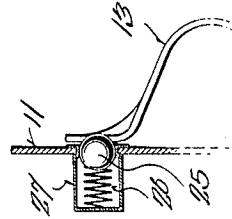

Fig. 5.

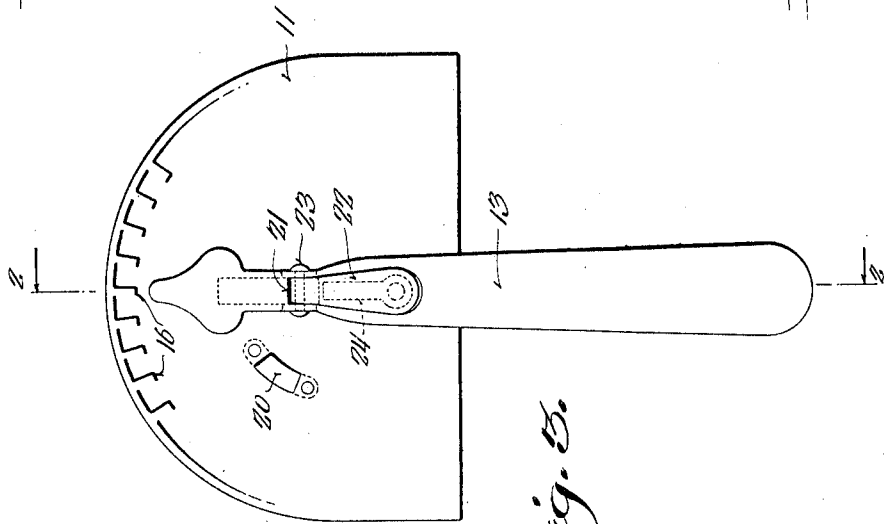

Fig. 6.

W. H. Wood:
Commissioner of Patents

Inventor:

John S. Brennan

Wm. H. Young & Co.
Attorneys

UNITED STATES PATENT OFFICE.

JOHN S. BRENNAN, OF MILWAUKEE, WISCONSIN.

OIL-BURNER.

1,317,153.

Specification of Letters Patent. Patented Sept. 30, 1919.

Application filed May 5, 1919. Serial No. 294,844.

To all whom it may concern:

Be it known that I, JOHN S. BRENNAN, a citizen of the United States, and resident of Milwaukee, in the county of Milwaukee and State of Wisconsin, have invented certain new and useful Improvements in Oil-Burners; and I do hereby declare that the following is a full, clear, and exact description thereof.

My invention relates to new and useful improvements in oil burners of that type shown in my copending application for patent filed Mar. 25th, 1919, Serial No. 284,946, wherein oil is supplied from a constant level source to a burner member including a fuel trough having disposed therein a relatively stationary incombustible wick body, regulation of the burning action being procured by raising and lowering the burner member bodily to vary its relation to the fuel supply level. When the burner is not in use, its bottom is raised above the fuel supply level, and when it is desired to light the burner, its bottom is moved a considerable distance below the level of fuel supply to procure ready and complete impregnation of the wick body with oil, various intermediate dispositions of the burner member effecting different degrees of burning action.

Practice has demonstrated that, in adjusting the normal burning position of the burner, there is a liability for some operators to shift the burner too far downwardly and thus dispose it in lighting position, with a consequent flooding of the burner which results in a smoking and unsatisfactory operation.

It is therefore primarily the object of my invention to provide an arrangement for positively determining the practical limit of high-burning operation of the burner which, at the same time readily permits movement of the burner to lighting position when desired.

It is more particularly my object to provide a detent means associated with the indicator dial plate and operating lever of a burner of this type, which is releasably effective to halt burner lowering movement of the lever at the practical limit of its normal burning action.

With the above and other objects and advantages in view, my invention resides in the novel combinations, formation and arrangement of parts hereinafter more fully

described and particularly pointed out in the appended claims.

In the accompanying drawings:

Figure 1 is an elevational view of the operating lever and dial plate of a burner of the class described, showing one embodiment of my invention associated therewith.

Fig. 2 is a view, partly in section of the burner operating mechanism, showing another embodiment of my invention, the plane of section being indicated by the line 2-2 of Fig. 3.

Fig. 3 is an elevational view of what is shown in Fig. 2.

Fig. 4 is an elevational view of the lever and plate showing a still further embodiment of my invention.

Fig. 5 is a sectional view on a plane indicated by the line 5-5 of Fig. 4 and

Fig. 6 is a sectional view similar to Fig. 5, but showing a still further embodiment of my invention.

Referring now more particularly to the drawings, 10 designates a burner bracket having its forward end down turned for securement thereto of a vertical dial plate 11, said dial plate and bracket being apertured to form a journal for an operating shaft 12. To procure rotation of the shaft and at the same time indicate the position of the burner relative to the fuel level line, a lever bar 13 is obliquely secured to the outer end of the shaft, the major portion of the lever extending downwardly to form a handle, while the remaining portion of the lever is inclined toward the dial and forms an indicator. The dial plate is provided with symbols 14 and 15 at opposite sides of the shaft for indicating respectively the upper and lower limits of movement imparted to the burner by the shaft 12, the burner being conventionally indicated as *a*. Intermediate of the symbols 14 and 15, the plate is provided with a series of symbols 16 for indicating the various adjustments of the burning position of the burner.

My invention resides in the provision of releasable means for halting movement of the actuator lever when its indicating portion reaches approximately the endmost symbol 16 adjacent the lighting-position symbol 15. The means shown in Fig. 1 comprises a pawl 17^a intermediately pivoted to a peripheral lug 17 of the dial plate, the outer end of the pawl being engageable with a stop 18 on the lug 17 and its inner end

portion being engageable by the indicator portion of the actuator lever in its counter-clockwise movement from burning to lighting position, thus affording a positive stop for the lever and preventing the accidental movement of the burner past its normal maximum burning position. To procure the lighting position of the burner, it is merely necessary to rock the pawl out of the path of the lever prior to the movement of the lever past the pawl. In movement of the lever from lighting to normal burning position, it trips the pawl to permit movement therepast. The pawl is urged to lever engaging position by gravity, and its lower end is returned to form a finger piece and abutment for the lever.

In the embodiment of my invention shown in Figs. 2 and 3, a projection 20 is provided on the face of the dial plate adjacent the endmost burning position symbol 16, this projection being taperingly increased in width from the lighting symbol 15 and terminating in an abutment shoulder. The actuator lever 13 is provided with a transverse slot 21 adjacent its bound of securement to the shaft 12, and the intermediate portion of a pawl lever 22 is passed through this slot and pivoted at 23 to the actuator lever. One end portion of this pawl is engageable with the shoulder of the projection 20, while the other end portion of the pawl lever forms a finger piece which may be pressed by the hand of the operator grasping the lever 13 to retract the pawl lever and permit movement of the actuator lever past the projection to lighting position. The pawl lever is urged to engaging position by a leaf spring 24 bearing against its finger piece end portion and secured to the actuator lever preferably by the means which attaches said lever to the shaft 12. Figs. 5 and 6 show a still further modification wherein movement of the actuator lever from burning to lighting position is effected by overcoming a certain spring resistance which is effected in the present instance by a detent ball 25 urged to partially project through a restricted opening in the dial plate for engagement by the indicator end portion of the actuator lever, this detent ball being engaged by a spring 26 disposed in a housing 27 projecting from the rear face of the dial plate.

As shown in Fig. 6, this yieldable resilient detent action may be effected by a rounded

projection 28 struck from the surface of the dial plate 11, said projection being engageable with the indicator portion of the lever 13, movement of the indicator portion past the projection in either direction being procured by the resilient yielding of the lever-portion.

In burners wherein the lowering movement of the burner trough procures automatically a spaced relation of the burner trough and drum, as in my said co-pending application, my improved releasable detent means also serves to prevent spacing of the drum from the burner trough in the adjustment of burning position of the burner trough.

While I have shown and described various structures embodying my invention, it will be appreciated that still other embodiments may be employed to meet differing conditions of manufacture and use without departing in any manner from the spirit of my invention.

What is claimed is:

1. The combination with a burner shiftable to procure its various lighting and burning positions, of a dial member, a burner shifting member connected with the burner and movable across the face of the dial member from burning to lighting positions, and a pawl pivotally carried by one of said members and engageable with a stop portion of the other member to normally prevent movement of the burner shifting member from burning to lighting position, said pawl being movable from the path of said stop portion to permit such movement of the burner shifting member.

2. The combination with a burner shiftable to procure its various lighting and burning positions, of a dial plate, a burner operating lever movable across the face of the dial plate, a pawl intermediately pivoted on the dial plate, one end portion of the pawl being engageable by said lever in its movement from lighting to burning position, and a stop engageable with the pawl to prevent its movement in the lighting direction of movement of the lever.

In testimony that I claim the foregoing I have hereunto set my hand at Milwaukee, in the county of Milwaukee and State of Wisconsin.

JOHN S. BRENNAN.