

No. 705,207.

Patented July 22, 1902.

E. G. CHARLEBOIS.
SHEET METAL SIDING.
(Application filed Jan. 27, 1902.)

(No Model.)

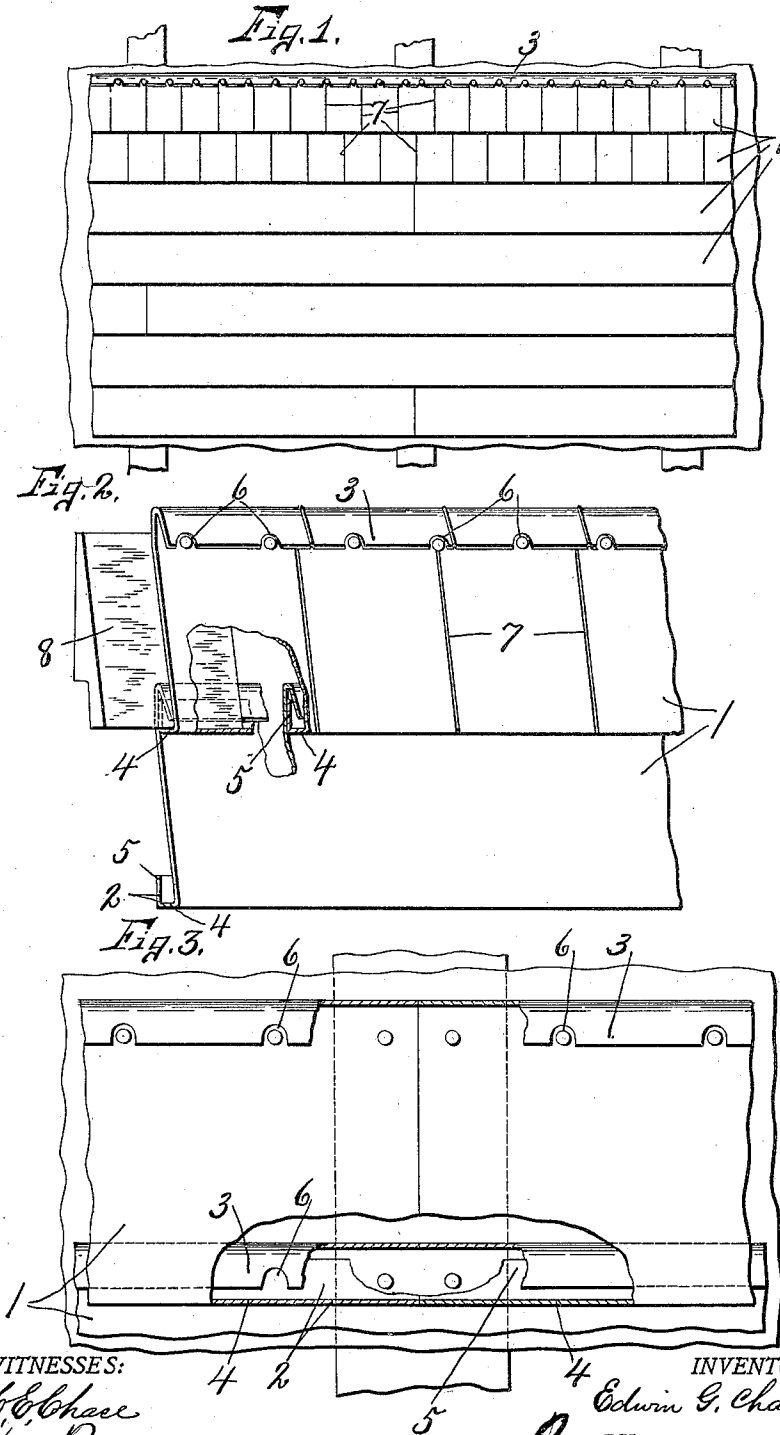

WITNESSES:
W. S. Chase
Wm. Brewer.

INVENTOR
Edwin G. Charlebois
BY
Smith & Denison
ATTORNEYS.

UNITED STATES PATENT OFFICE.

EDWIN G. CHARLEBOIS, OF WATERTOWN, NEW YORK.

SHEET-METAL SIDING.

SPECIFICATION forming part of Letters Patent No. 705,207, dated July 22, 1902.

Application filed January 27, 1902. Serial No. 91,467. (No model.)

To all whom it may concern:

Be it known that I, EDWIN G. CHARLEBOIS, of Watertown, in the county of Jefferson, in the State of New York, have invented new and useful Improvements in Sheet-Metal Siding, of which the following, taken in connection with the accompanying drawings, is a full, clear, and exact description.

My invention relates to improvements in sheet-metal siding.

The object of this invention is to produce a siding composed of a series of sheet-metal strips or sections adapted to interlock with each other at their longitudinal edges and having the external appearance of clapboard or shingle siding.

A further object of this invention is to so construct and arrange the interlocking flanges as to permit the strips to be readily and easily assembled or secured to the studing or sheathing in such manner as to conceal the fastening means.

Another object is to interlock the longitudinal flanges of adjacent strips or sections in such manner that the weather exposure may be varied a limited distance and the sections adjusted transversely relatively to each other to conform to certain limitations of space—as, for instance, between the water-table and sills—without mutilating or otherwise impairing the integrity of the strip.

A further object is to score or crease these strips or sections transversely to represent shingle-siding.

To this end the invention consists in the construction and formation of a siding strip or section as hereinafter fully described, and pointed out in the claims.

Referring to the drawings, Figure 1 is an elevation of a portion of the side wall of a building, showing the application of my improved siding thereto. Fig. 2 is an enlarged perspective view of two adjacent strips or sections of the siding, showing the manner of interlocking their adjacent longitudinal edges. Fig. 3 is an enlarged face view of one of my improved siding strips or sections, showing particularly the means for securing the same to the sheathing or studs.

Similar reference characters indicate corresponding parts in all the views.

As seen in the drawings, Figs. 2 and 3, this

invention consists, essentially, of a lengthwise sheet-metal strip 1, having one of its longitudinal edges provided with an angular flange 2, and its other edge is formed with a longitudinal flange 3. These strips or sections may be of any desired length, being usually of substantially the same length as ordinary clapboards, the flanges 2 and 3 being formed integral with the body of the metal by rolling or stamping the same to the desired form. The flange 2 is preferably angular in cross-section, the portion 4 adjacent to the body of the metal being bent inwardly at substantially right angles to said body, and the free longitudinal edge 5 of the portion 4 is bent upwardly toward the opposite longitudinal edge of the strip or section and is disposed in a plane substantially parallel with the inner face of said opposite longitudinal edge. The flange 3 is preferably folded outwardly and downwardly toward the lower edge of said strip, and its free longitudinal edge is preferably curved outwardly and is slightly separated from the adjacent portion of the section, being usually formed with a series of recesses 6, made by cutting away portions of the flange 3 at intervals, for permitting the insertion of suitable fastening members, as nails, through the contiguous portion of the strip or section above or within the free longitudinal edge of the flange 3, so that when the flanges 2 and 3 are interlocked the nails and recesses are entirely concealed. The lower edge of the strip or section, or the portion 4 of the angular flange 2 is preferably of greater width than the corresponding upper edge of said strip or section at the junction of the flange 3 thereof for the purpose of deflecting the body of the strip or section outwardly from a vertical plane when said strip or section is placed in position, and it is therefore evident that the vertical inclination produces substantially the same effect in appearance and utility as the ordinary clapboard.

It is well known to those skilled in the art of building structure that wood shingles are frequently used for siding, and in order to produce substantially the same visual effect with my improved siding as the ordinary wood-shingle siding I preferably provide the strips or sections with transverse scores or

creases 7, which are arranged at regular or irregular predetermined intervals throughout the length of said strip or section in such manner as to give the appearance of wood shingles when the strips or sections are secured in position upon the building.

It is apparent from the foregoing description that the inner face of the flange portion 5 and the inner face of the opposite edge of the body of the strip lie in substantially the same vertical plane when secured in position and that in assembling the strips the first or bottom course is secured in position upon the sheathing or studs. The next superimposed course is then placed in position by inserting the portions 5 of the flange 2 beneath the flange 3, and moving said strips or sections upwardly to give the desired lap, whereby said flanges are interlocked with each other, the flange 3 overlapping the flange 5, whereupon said second course is secured in position in the manner previously described, this operation being continued until the surface to be sided is entirely covered.

It is to be understood that the siding-sections are manufactured complete before being applied to the building and that the assembled sections in the finished siding are the same in cross-section as when manufactured. It is also evident that when these strips or sections are secured in position the fastening members are entirely concealed by the flange portions 5.

The joints at the abutting ends of the several courses of strips or sections are preferably staggered in the usual manner, and in order to effect an absolute water-tight and weatherproof joint I usually provide a suitable filling or back piece of wood, metal, or any other desired material 8 of sufficient length to entirely cover any opening in the joint and is preferably interposed between the inner faces of the adjacent ends of the strips or sections and the outer face of the sheathing or studs or other surface to which the siding is secured. This filling or back piece 8 is preferably shaped to any cross-section to conform to and entirely fill the space between the strips or sections and the surface to which it is secured and preferably abuts at its lower edge against the inner face of the portion 4 of the flange 2, the object of this being to render the joint absolutely weatherproof and at the same time to conduct any water or rain beneath the lower edge of the strip or section, thereby forming an even surface at said abutting ends.

The operation of my invention will now be readily understood upon reference to the foregoing description and the accompanying drawings, and it will be noted that some change may be made in the detail construction and arrangement of the various features of my invention without departing from the spirit thereof. Therefore I do not limit myself to the precise construction of details shown and described, as, for instance, in some cases, it may be desired to overlap the adjacent ends of the strips, and thereby dispense with the back piece of filling 8.

Having thus fully described my invention, what I claim, and desire to secure by Letters Patent, is—

1. The combination of sheet-metal siding strips or sections arranged end to end, and a filling or back piece interposed between the inner faces of the meeting ends of said strips or sections and the surface to which said strips or sections are secured for the purpose specified.

2. As a new article of manufacture a sheet-metal siding strip or section having its opposite longitudinal edges bent in opposite directions for forming interlocking flanges operating as described, one of said flanges having portions thereof cut away for forming cut-outs or recesses for permitting the insertion of the fastening members through the body of the strip or section.

3. As a new article of manufacture a sheet-metal siding strip or section having its opposite longitudinal edges provided with oppositely-turned flanges of unequal projection from the main body, said strips or sections being provided with transverse creases or scores for the purpose set forth, portions of the free edge of the upper flange being cut away at intervals to form recesses to receive the fastening members.

4. A sheet-metal-siding strip or section having one of its longitudinal edges bent inwardly and upwardly and its other longitudinal edge bent outwardly and downwardly for forming opposite longitudinal flanges, the upturned edge of the former flange being separated a greater distance from the body of the strip or section than the free edge of the other flange.

In witness whereof I have hereunto set my hand this 24th day of January, 1902.

EDWIN G. CHARLEBOIS.

Witnesses:

H. E. CHASE,
MILDRED M. NOTT.