



(51) International Patent Classification:

E02F9/24 (2006.01) E02F3/36 (2006.01)
F15B 20/00 (2006.01)

(21) International Application Number:

PCT/EP20 18/067306

(22) International Filing Date:

27 June 2018 (27.06.2018)

(25) Filing Language:

English

(26) Publication Language:

English

(71) Applicant: VOLVO CONSTRUCTION EQUIPMENT AB [SE/SE]; 63 1 85 ESKILSTUNA (SE).

(72) Inventors: LOISY, Pierre; 16 me Berthet Burlet, 73000 CHAMBERY (FR). OGGERO, Alain; 108 chemin du Rhone, 01300 VIRIGNIN (FR).

(74) Agent: CABINET PLASSERAUD; 66 me de la Chaussee d'Antin, 75440 PARIS CEDEX 09 (FR).

(81) Designated States (unless otherwise indicated, for every kind of national protection available):

AE, AG, AL, AM, AO, AT, AU, AZ, BA, BB, BG, BH, BN, BR, BW, BY, BZ, CA, CH, CL, CN, CO, CR, CU, CZ, DE, DJ, DK, DM, DO, DZ, EC, EE, EG, ES, FI, GB, GD, GE, GH, GM, GT, HN, HR, HU, ID, IL, IN, IR, IS, JO, JP, KE, KG, KH, KN, KP, KR, KW, KZ, LA, LC, LK, LR, LS, LU, LY, MA, MD, ME, MG, MK, MN, MW, MX, MY, MZ, NA, NG, NI, NO, NZ, OM, PA, PE, PG, PH, PL, PT, QA, RO, RS, RU, RW, SA, SC, SD, SE, SG, SK, SL, SM, ST, SV, SY, TH, TJ, TM, TN, TR, TT, TZ, UA, UG, US, UZ, VC, VN, ZA, ZM, ZW.

(84) Designated States (unless otherwise indicated, for every kind of regional protection available):

ARIPO (BW, GH, GM, KE, LR, LS, MW, MZ, NA, RW, SD, SL, ST, SZ, TZ, UG, ZM, ZW), Eurasian (AM, AZ, BY, KG, KZ, RU, TJ, TM), European (AL, AT, BE, BG, CH, CY, CZ, DE, DK, EE, ES, FI, FR, GB, GR, HR, HU, IE, IS, IT, LT, LU, LV, MC, MK, MT, NL, NO, PL, PT, RO, RS, SE, SI, SK, SM,

(54) Title: METHOD AND SYSTEM TO SECURELY MANAGE QUICK COUPLING OF TOOLS IN AN EARTH MOVING EQUIPMENT

FIG. 2

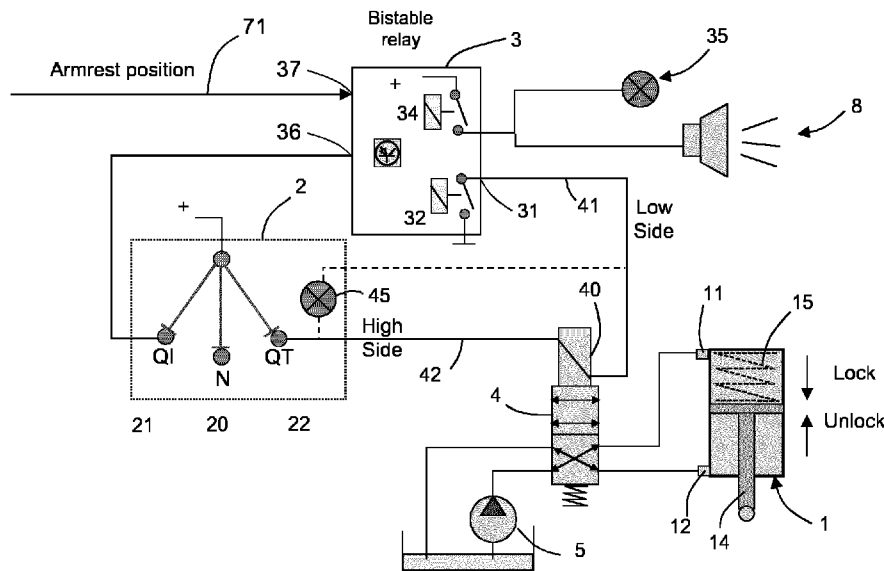

(57) Abstract: A control device and method for controlling a disengaging actuator (1) of a tool attachment, the device comprising a three-state switch (2), with a middle neutral position (20), a first end position (21), and a second end position (22), a control unit (3, 3'), having an input corresponding to an activation of the first end position (21), an electro-valve (4) coupled hydraulically to the disengaging actuator (1), having a coil (40), a first control line (41) and a second control line (42) coupled respectively to first and second terminals of the coil (40) of the electro-valve, wherein one of the first and second control lines is coupled to the second end position (22) of the three-state switch and the other of the first and second control lines is coupled to an output of the control unit, such that both control lines have to be activated to allow disengagement.



TR), OAPI (BF, BJ, CF, CG, CI, CM, GA, GN, GQ, GW,
KM, ML, MR, NE, SN, TD, TG).

Published:

— *with international search report (Art. 21(3))*

**METHOD AND SYSTEM TO SECURELY MANAGE QUICK COUPLING OF
TOOLS IN AN EARTH MOVING EQUIPMENT**

5

FIELD OF THE INVENTION

The present invention relates to methods and systems for securely managing quick coupling of tools in earth moving equipment. Tools attached to earth moving equipment can be buckets, hammers, or any accessory that can be attached to the distal end of the powered arm of the earth moving equipment. Earth moving equipment comprise in particular excavators and the like.

BACKGROUND OF THE DISCLOSURE

Construction machines, including excavators, are fitted with various optional devices or tools, including buckets, breakers, hammers, shears, dozer blades, etc., at the tip of the arm as a working device to accommodate the work required at the construction site. Typically, the optional device or 'tool' can be mounted to a quick coupler system which enables a quick replacement of one tool by another tool.

The quick coupler system is usually operated by hydraulic pressure. Most quick coupler systems comply with ISO standard ISO 1303 1.

Equipment manufacturers seek to decrease the likelihood of an incident or inadvertent event during the exchange phase of the tool, as taught for example by document W02012085500.

The inventors have found that there remains a need to further improve the safety of such quick coupler systems.

25

SUMMARY OF THE DISCLOSURE

According to one aspect of the present invention, it is disclosed a control device for controlling a disengaging actuator of a tool attachment, the device comprising

- a three-state switch, with a middle neutral position, a first end position, and a second end position,
- a control unit, having an input corresponding to an activation of the first end position,
- a electro-valve coupled hydraulically to the disengaging actuator,
- a first control line and a second control line coupled respectively to first and second terminals of the coil of the electro-valve,

wherein one of the first and second control lines is coupled to the second end position of the three-state switch and the other of the first and second control lines is coupled to an output of the control unit such that both control lines have to be activated to allow disengagement.

Thanks to these dispositions, first and second control lines are respectively controlled
5 by channels having a different technology (hardwire versus logically controlled), thereby decreasing the risk of common mode failure.

We also note that, unlike the conventional art, none of the two terminals of the coil is permanently established (no permanent connection to positive supply or ground). Said otherwise, both terminals of the electro-valve coil are selectively controlled, not only one.

10 There is therefore provided functional and hardware protection against any single failure from hardware, software or operator; also most user misuse can be avoided.

Only a multiple point failures (at least two) can lead to undesirable event.

In the present disclosure, the term “control system” can also be used instead of “control device” since several physical units are involved.

15 Preferably, the first end position is biased toward the middle neutral position, said otherwise, the first end position is unstable (pushbutton like). Preferably, the term ‘middle’ about the neutral position means that the neutral position lies between the first and second end positions.

Here ‘control lines’ are electrical control lines; said electrical control lines are configured
20 to energize the coil of the electro-valve for moving the plunger away from its rest position.

The proposed solution enhances safety integrity and resistance to faults of the arrangement of electro-hydraulic means used in the context of the quick coupler control function in excavators.

25 This decreases the likelihood of dependent failures to a minimal extent, and by that increases resistance to faults. The rejected faults are furthermore either caused by operator misuse or system failures.

In various embodiments of the invention, one may possibly have recourse in addition to one and/or other of the following arrangements, taken alone or in combination.

30 According to one possible option, the first control line is coupled to an output of the control unit.

According to one possible option, the first control line is energized when pulled to ground. Such electrical or electronic control stage, pulling to ground inside the control unit,

turns out to be of good availability and cost effectiveness.

According to one possible option, the second control line is coupled to the second end position of the three-state switch.

5 According to one possible option, the second control line is energized when supplied by positive voltage. Thereby, since short circuits to ground appears more often than short circuits to positive voltage, the likelihood of controlling the second line in an inadvertent manner the second line is decreased.

According to one possible option, the control unit comprises a bi-stable relay. This is a sturdy, well known and reliable solution.

10 According to one possible option, the control unit comprises a solid state control stage to control the first control line. Protection is provided against short circuits.

According to one possible option, the control unit may comprise software. This configuration is more open to take into account auxiliary additional inputs or parameters in order to abort an ongoing quick change phase if necessary.

15 According to one possible option, the control device may further comprise at least one warning light (35,45), giving visual feedback and indications to the operator.

20 According to one possible option, the control device may comprise a first warning light controlled in parallel with one of the first and second control lines, and a second warning light controlled in parallel with the electro-valve. The first warning light notifies the user(s) about an ongoing quick coupling changing phase/sequence; whereas the second warning light notifies the user(s) about an ongoing disengagement of the disengaging actuator.

According to one possible option, the control device may further comprise an audio warning reflecting an ongoing quick change phase; this provides a good coverage for user warning whatever the stand/posture of the operator.

25 According to one possible option, the control device may further comprise an armrest position sensor and armrest position input at the control unit, such that an ongoing quick change phase is aborted whenever the armrest is raised. Advantageously, thanks to the position sensor and the logic attached to this information, whenever the operator goes out the machine cabin, the quick coupler changing phase is aborted

30 According to one possible option, the three-state switch is arranged on a machine armrest. Thereby, the machine armrest has to be in the operative low position when starting a quick coupler changing phase; further, it is difficult, to manoeuver the three-state switch when the armrest is raised. When the armrest is raised, even if the three-state switch is actuated, this has

no effect and does not start a changing sequence.

According to one preferred option, the second end position is stable and mechanically protected from direct actuation; this prevents inadvertent actuation of the second end position.

According to one possible option, there are provided an auxiliary knob interposed
5 between two protective cheeks, and the auxiliary knob has to be actuated before allowing the toggling of the three-state switch to the second end position. Thereby, only an intentional action with the tip of a finger can lead to effective toggling to the second end position, achieving efficient misuse protection.

According to one preferred option, the electro-valve is a 4/2 valve. This is a reliable well
10 known solution.

The present disclosure is also directed to an electro-hydraulic system comprising a hydraulic disengaging actuator, a hydraulic circuit with a pump and a control device as described above.

The present disclosure is also directed to a control method to be carried out in a device
15 for controlling a disengaging actuator of a tool attachment, comprising a three-state switch, with a neutral position, a first end position, and a second end position, a control unit, a electro-valve coupled hydraulically to the disengaging actuator, a first control line and a second control line coupled respectively to first and second terminals of the coil of the electro-valve,

20 the method comprising the following steps:

/a/ a first temporary actuation of the three-state switch to the first end position, causes a start/beginning of a quick coupler changing phase/sequence and causes the first control line to be energized and maintained in an energized state, accompanied with visible and audio warnings,

25 */b/* a toggling of the three-state switch to the second end position, causes the second control line to be energized through the three-state switch, and causes the actuation of the electro-valve which in turn causes the actuation of the disengaging actuator,

Id allowing the physical change of the tool/implement attached to the quick coupler attachment, (moving the excavator arm)

30 */d/* a toggling of the three-state switch back to the neutral position, causes at least the second control line to be de-activated, which causes the de-actuation of the electro-valve which in turn causes the re-engagement of the disengaging actuator,

Id a second/further temporary actuation of the three-state switch to the first end position,

causes a termination of the quick coupler changing phase.

The overall warnings (audio and visual) are cleared at step *Id*.

We note here that instead of “quick coupler changing phase”, the term “quick coupler changing sequence” can also be used.

5 According to one possible option, at step *Id*, the second/further temporary actuation of the three-state switch to the first end position, further causes the first control line to be deactivated.

According to one possible option, the quick coupler changing phase is aborted whenever an armrest raised information is inputted.

10 According to one possible option, the control device has no time-out function, abortion is achieved by a specific action or condition, abortion also occurs in case of loss/interruption of electrical power supply.

BRIEF DESCRIPTION OF THE DRAWINGS

15 Other features and advantages of the invention appear from the following detailed description of one of its embodiments, given by way of non-limiting example, and with reference to the accompanying drawings, in which:

- Figure 1 illustrates a diagrammatic side view of a bucket attached with a quick coupling system to an arm of a machine.

20 - Figure 2 is exemplary block diagram of a first embodiment of a control device according to the present invention,

- Figure 3 is exemplary block diagram of a second a second embodiment of a control device according to the present invention,

- Figure 4 illustrates a time chart of the method involved therein,

25 - Figure 5 illustrates one embodiment of the three-state switch,

- Figures 6A, 6B and 6C illustrate different states of the three-state switch,

- Figure 7 illustrates another time chart of the method involved therein,

- Figure 8 illustrates an armrest of the earth moving equipment.

30 DETAILED DESCRIPTION OF THE DISCLOSURE

In the figures, the same references denote identical or similar elements. For the sake of clarity, some elements may not be represented at scale.

As shown in figure 1, an earth moving equipment (‘excavator’ or ‘machine’ of this kind)

comprises a working arm having a distal end **61**. At the distal end of the working arm, there is provided a quick coupler system denoted **6**. In the illustrated example the quick coupler system comprises strong pins attached to the distal ends and strong pins or hooks to carry a bucket **62** or the like. There are provided various types of quick coupler system as described
5 in ISO standard 13031, as known per se.

In the context of the present invention, it has been illustrated a force locked engagement system with an engagement member denoted **64** and an actuator which is called in the following “disengagement actuator” (ref 1), since in the rest position, this actuator tends to push the engagement member in the secure locking state.

10 System layout

As apparent from Figure 2, the disengaging actuator **1** is such that its rest state corresponds to an engagement of the locking device to securely attach the tool to the machine arm **61**.

The disengaging actuator **1** is here a double-acting hydraulic cylinder with a first port **11**
15 and a second port **12**.

For the purpose of the safe rest state, there is provided a spring **15** that pushes the rod **14** of the cylinder toward the locking state, even when no hydraulic pressure is available.

Besides the above-mentioned pump **5**, there is provided a hydraulic tank and an electro-valve **4** between the pump **5** and the hydraulic cylinder.

20 According to the illustrated example, the electro-valve **4** is a 4/2 valve, i.e. with four ports, and two plunger positions. Here it is an ON/OFF valve. This kind of electro-valve has a control coil **40**, a return spring to bias the plunger to a rest position. This kind of electro-valve is known per se thus not described in detail here.

25 However, alternate solutions for the electro-valve or the hydraulic circuit are also possible.

Further, when hydraulic pressure is available (hydraulic pump **5** is running), the default control by the hydraulic circuit is to supply hydraulic pressure through first port **11** in the chamber where the pushing spring is located. The rest position of the electro-valve corresponds to the locking state of the disengaging actuator.

30 Only when ad-hoc conditions are met to disengage the disengaging actuator **1**, the plunger of the electro-valve **4** is to be controlled away from its rest position; when the coil **40** is energized, the plunger moves away from its rest position and, in this case only, the hydraulic pressure is supplied to the second port **12** of the hydraulic cylinder, whereas at the

same time the first port 11 is connected to the tank. Under this condition, the rod 14 moves back and the quick coupler is unlocked, allowing physical exchange of tool.

As shown on figure 2, the control device comprises a three-state switch 2. The three-state switch comprises a middle neutral position 20 (lettered 'N'), a first end position 21 (lettered 'QF'), and a second end position 22 (lettered 'QT'). There is provided at least an electrical input supplying the three-state switch with positive voltage (12V or 24V according to the network voltage of the machine). There is provided a first electrical output corresponding to the first end position, coupled by an electrical link 43 or wire to the control unit. There is provided a second electrical output corresponding to the second end position, coupled by an electrical link 42 or wire to the electro-valve 4. The internal electrical layout can be as simple as represented at figure 2, or can be more elaborate with two independent electrical commutators for the same overall function.

As illustrated on figure 8, the three-state switch 2 is arranged on a machine armrest 7. Besides, the armrest 7 comprises one or more joystick 75 or levers to controls the different actuators of the machine (arm, tool auxiliaries, etc, without excluding crawlers).

The control device comprises a first control line 41 a second control line 42 coupled respectively to first and second terminals of the coil 40 of the electro-valve.

The control device comprises a control unit 3. The control unit 3 has an input 36 corresponding to an activation of the first end position **21**.

In the illustrated example, the first control line 41 is energized when pulled to ground, i.e. Low Side active. However we note that the contrary can also be possible.

In the illustrated example, the second control line 42 is energized when supplied by positive voltage (either 12V or 24V according to the onboard electrical network). However we note that the contrary can also be possible.

The first control line 41 is coupled to an output denoted 31 of the control unit.

The output 31 is driven by a relay 32 included in the control unit.

The control unit 3 comprises a bi-stable relay. A bi-stable relay is here a relay having a basic logic control, with a basic latch function, i.e. one impulse set the latch and a further impulse unset the latch.

In the illustrated example, the control device comprises a first warning light 35, reflecting an ongoing quick change phase. The first warning light 35 can be controlled in accordance with the logic on first control line.

In the illustrated example, the control device comprises a second warning light 45,

reflecting a disengagement state of the disengaging actuator. The second warning light **45** can be controlled in accordance with the coil control.

One of the first and second warning light **35,45** can be located in the three-state switch **2**.

5 In the illustrated example, the control device comprises an audio warning **8** reflecting an ongoing quick change phase.

The audio warning **8** can be any kind of beeper, buzzer. There may be one audio warning device inside the cabin of the machine. There may be one audio warning device outside the cabin.

10 There may be one warning light inside the cabin of the machine There may be arranged a turning light on the top of the cabin.

In the illustrated example, the warning devices give strong notice of an ongoing quick coupler changing sequence are driven by a separate relay **34**. However they could also be driven from the output **31** controlling the first line.

15 In the illustrated example, the control device comprises an armrest position sensor **72** and armrest position input **71** such that an ongoing quick change phase is aborted whenever the armrest is raised.

20 As apparent from figure 3, the control unit **3'** may comprise a communication capability via a serial bus **90** (CAN bus, LIN bus or any like solution). The control unit **3'** may comprise a microcontroller. There may be provided a HMI screen **95** (HMI = Human Machine Interface) to provide a series of menu driven or sequence driven displays intended to help to the user.

25 Here, in the shown example, the control unit **3'** comprises a solid state control stage **33** to control the first control line **41**. However a controlled relay can also be considered. Here, in the shown example, the control unit **3'** may comprise a smart FET (Field Effect Transistor) with a current sensing capability; this provides protection against short circuits and overheating.

30 Three-state switch

Figure 5 depicts the three-state switch **2** which comprises a base **29** and a rocker **28**. One or more warning light **35;45** already mentioned can be located in the three-state switch **2**.

In the illustrated example here, the three-state switch **2** comprises an auxiliary knob **26**

interposed between two protective cheeks **24**. The auxiliary knob **26** provides protection against direct actuation by pushing the rocker **28**. A known-per-se mechanical design inside the three-state switch **2** requires a prior actuation of the auxiliary knob **26** to release the rocking of the three-state switch **2** to the second end position **22**.

5 In other words, the auxiliary knob **26** has to be actuated before allowing the toggling of the three-state switch **2** to the second end position **22**.

Figure 6A depicts the three-state switch **2** in the neutral position. The rocker **28** is in a middle stand between the two end positions that are described below.

10 Figure 6B depicts the three-state switch **2** in the first end position **21**. The first end position is unstable (pushbutton like), the rocker **28** is biased to the neutral position by a spring. Only impulses are therefore achieved, stable state.

Figure 6C depicts the three-state switch **2** in the second end position **22**.

As apparent from figure 6C, only an intentional action with the tip of a finger UF can lead to effective toggling to the second end position **22**, achieving efficient misuse protection.

15 The second end position is stable, and (with or without mechanical protection) changing from the second end position to the neutral position and vice-versa is called “toggling”.

Control method

As illustrated on figure 4, the propose method comprises the following steps:

20 Step /a/ a first temporary actuation of the three-state switch to the first end position **21**, causes a start/beginning of a quick coupler changing phase/sequence and causes the first control line to be energized and maintained in an energized state, accompanied with visible and audio warnings,

25 Step /b/ : a toggling of the three-state switch to the second end position **22**, causes the second control line to be energized through the three-state switch **2**, and causes the actuation of the **electro-valve 4** which in turn causes the actuation of the disengaging actuator **1**,

Step *Id* : allowing the physical change of the tooFimplement attached to the quick coupler attachment, here the operator uses the joystick **75** to disengage old tool, then moves the excavator arm to a new tool and engage the new tool.

30 Step /d/ : a toggling of the three-state switch back to the neutral position **20**, causes at least the second control line to be de-activated, which causes the de-actuation of the electro-valve **4** which in turn causes the re-engagement of the disengaging actuator **1**,

Step *Id* : a second/further temporary actuation of the three-state switch to the first end

position **21**, causes a termination of the quick coupler changing phase, and preferably in practice the second/further temporary actuation of the three-state switch to the first end position **21**, causes the first control line to be de-activated.

At step /e/, preferably, audio and visual warnings are stopped, i.e. stated otherwise, the overall warnings (audio and visual) are cleared.

In one embodiment, the control device has no time-out function, abortion of the quick coupler changing phase is achieved only by a specific action on the three-state switch 2.

According to a preferred variant, the quick coupler changing phase is also aborted whenever an armrest raised information **71** is inputted at the control unit.

Further, abortion also occurs in case of loss/interruption of electrical power supply.

We note here that a quick coupler changing phase abortion by a second/further temporary actuation of the three-state switch to the first end position **21** can occur during step *Id*.

It should be noted that when the quick coupler changing phase is still active (before step *Id*) steps /b/,/c/ and /d/ can be repeated a second time; this can happen if the operator realizes that the coupling is not correct, the operator can trigger again disengagement to correct the excavator arm position with regard to the bucket position.

The skilled person understand that, advantageously, only a predetermined sequence intentionally performed by an operator can allow tool disengagement.

If, for instance, the three-state switch is moved to the second end position **22** without having first move it to the first end position **21**, then the first control line 41 remains not energized. As a result, even though the second line 42 is energized, no current flow in the coil 40 and the plunger of the electro-valve remains in the safe rest position. When the quick coupler changing phase has not been initiated properly, there is no risk of undesirable event.

According to another example, if the three-state switch 2 has been moved to the second end position **22** before the legal operator took control of the machine, for example another person has tampered the controls of the machine (intentionally or not), **the same result occurs** even though the second line 42 is energized, no current flow in the coil 40 and the plunger of the electro-valve remains in the safe rest position since the quick coupler changing phase has not been initiated properly.

Miscellaneous

Figure 7 shows that an armrest raise interrupts the supply of the first control line **41**, and

therefore the disengaging actuator 1 is re-engaged. Also, it is noted that an armrest raised condition prevents a sequence to be initiated even though the three-state switch is actuated.

5 In an alternative embodiment, the first control line can be energized by positive supply (High side) and the second control line can be energized when pulled to ground (Low side).

The proposed configuration of control device and associated method is validated according to ISO13849-2:2012.

10 The visual warning lights can include with one or more Leds.

There may be provided a diagnosis function of the three-state switch; a three-state switch with a double stage can be used such that the control circuit 3,3' can detect various failures : open circuit, short circuit to ground, short circuit to positive supply.

15

CLAIMS

1. A control device for controlling a disengaging actuator (1) of a tool attachment, the device comprising
- 5 - a three-state switch (2), with a middle neutral position (20), a first end position (21), and a second end position (22),
- a control unit (3;3'), having an input corresponding to an activation of the first end position (21),
- a electro-valve (4) coupled hydraulically to the disengaging actuator (1), having a coil (40),
- 10 - a first control line (41) and a second control line (42) coupled respectively to first and second terminals of the coil (40) of the electro-valve,
- wherein one of the first and second control lines is coupled to the second end position (22) of the three-state switch and the other of the first and second control lines is coupled to an output of the control unit, such that both control lines have to be activated to allow
- 15 disengagement.
2. The device of claim 1, wherein the first control line (LS) is coupled to an output (31) of the control unit.
- 20 3. The device of claim 2, wherein the second control line (HS) is coupled to the second end position (22) of the three-state switch.
4. The device of any of the claims 1 to 3, further comprising at least a warning light (35,45).
- 25 5. The device of any of the claims 1 to 3, comprising a first warning light (35) controlled in parallel with one of the first and second control lines, and a second warning light (45) controlled in parallel with the electro-valve (4).
6. The device of any of the claims 1 to 5, further comprising at least an audio warning (8).
- 30 7. The device of any of the claims 1 to 6, further comprising an armrest position sensor and armrest position input (71) at the control unit.

8. The device of any of the claims 1 to 7, wherein the three-state switch (2) is arranged on a machine armrest (7).

9. The device of any of the claims 1 to 8, wherein the second end position (22) is stable and mechanically protected from direct actuation.

10. The device of any of the claims 1 to 9, wherein the electro-valve (4) is a 4/2 valve.

11. An electro-hydraulic system comprising a hydraulic disengaging actuator (1), a hydraulic circuit with a pump (5) and a control device according to any of the claims 1 to 10.

12. A control method to be carried out in a device for controlling a disengaging actuator of a tool attachment, comprising :

- a three-state switch (2), with a middle neutral position (20), a first end position (21), and a second end position (22),
- a control unit (3), having an input corresponding to an activation of the first end position (21),
- a electro-valve (4) coupled hydraulically to the disengaging actuator (1),
- a first control line and a second control line coupled respectively to first and second terminals of the coil (40) of the electro-valve,

the method comprising the following steps:

- /a/* a first temporary actuation of the three-state switch to the first end position (21), causes a start/beginning of a quick coupler changing phase and causes the first control line to be energized and maintained in an energized state, accompanied with visible and audio warnings,
- /b/* a toggling of the three-state switch to the second end position (22), causes the second control line to be energized through the three-state switch (2), and causes the actuation of the electro-valve (4) which in turn causes the actuation of the disengaging actuator (1),
- Id* allowing the physical change of the tool/implement attached to the quick coupler attachment, including moving the excavator arm,
- /d/* a toggling of the three-state switch back to the neutral position (20), causes at least the second control line to be de-activated, which causes the de-actuation of the electro-valve (4) which in turn causes the re-engagement of the disengaging actuator (1),
- Id* a second/further temporary actuation of the three-state switch to the first end position (21),

causes a termination of the quick coupler changing phase.

5 **13.** The method of claim 12, wherein at step **1d** the second/further temporary actuation of the three-state switch to the first end position (21), further causes the first control line to be deactivated.

14. The method of any of the claims 12 to 13, wherein the audio and visual warnings are cleared at step /e/.

10 **15.** The method of any of the claims 12 to 14, wherein the quick coupler changing phase is aborted whenever an armrest raised information is inputted at the control unit (3).

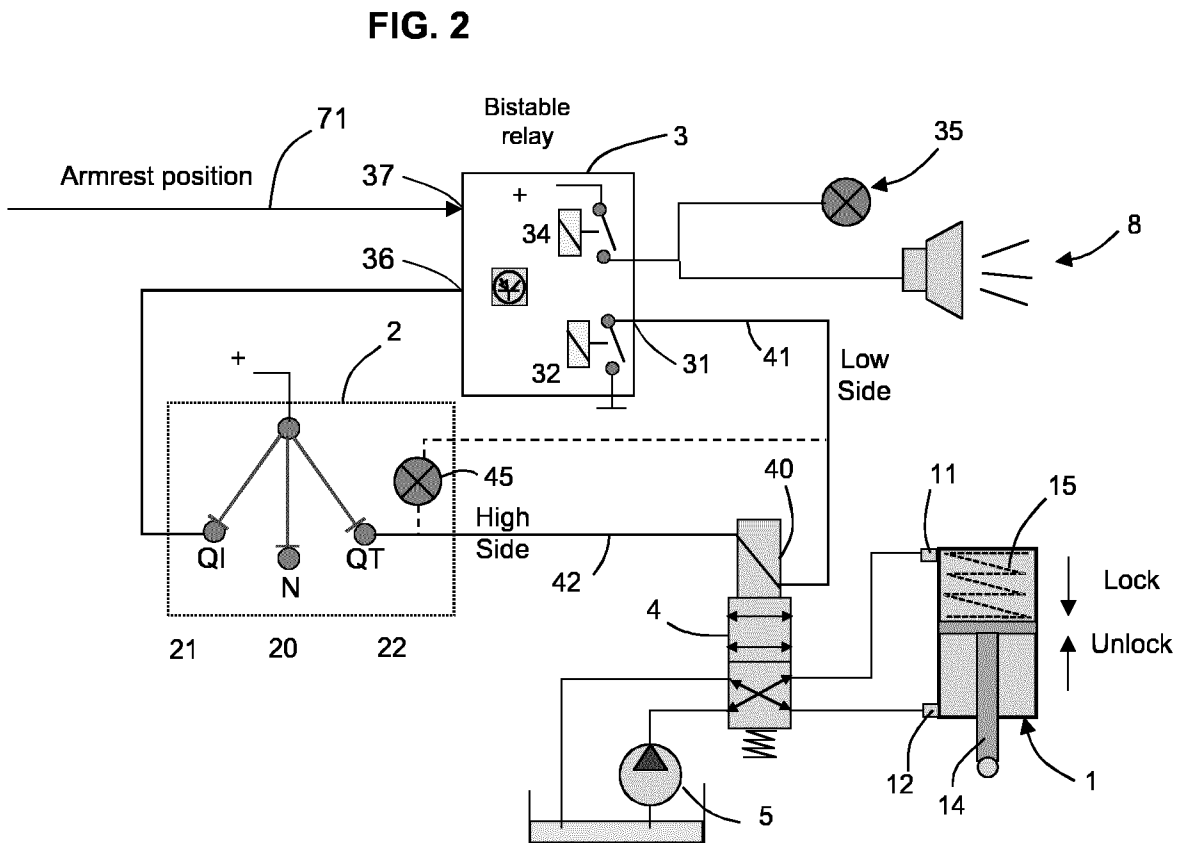
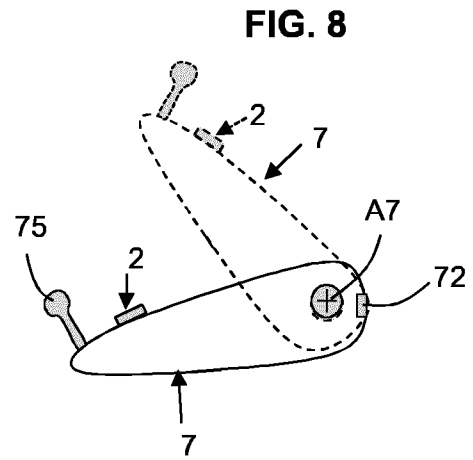
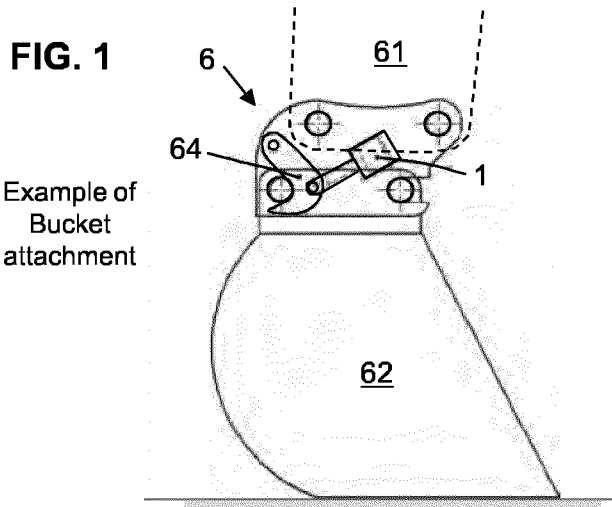

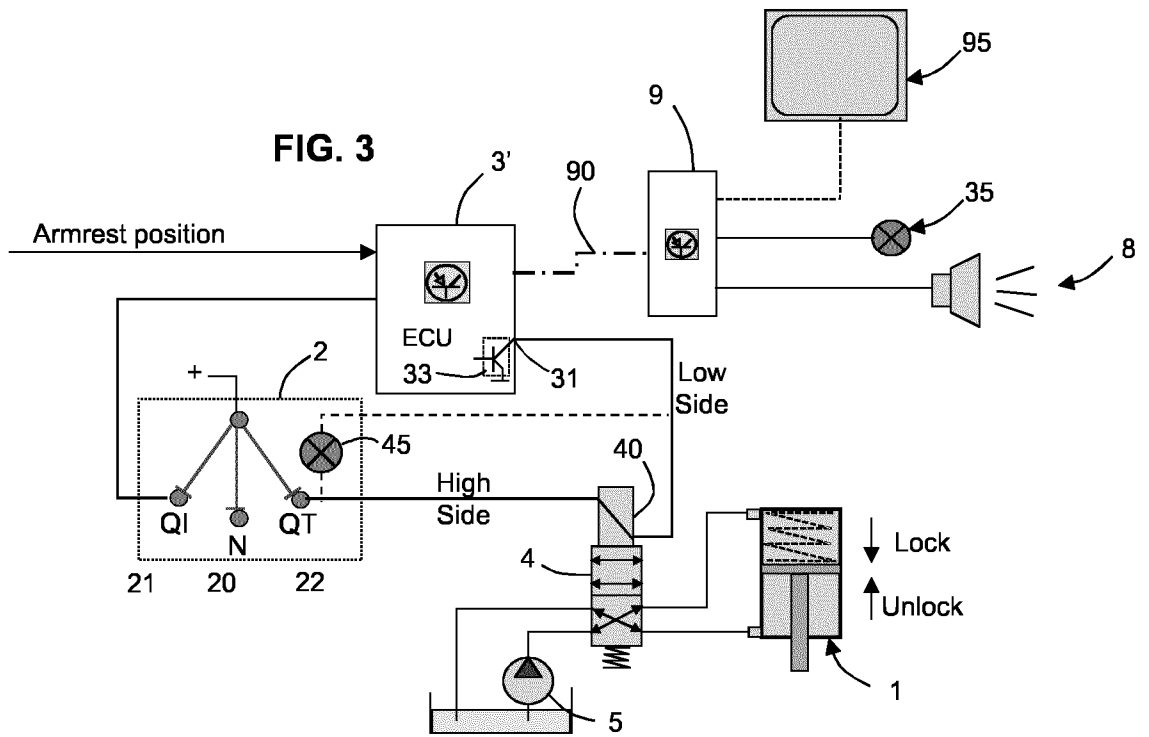

FIG. 4

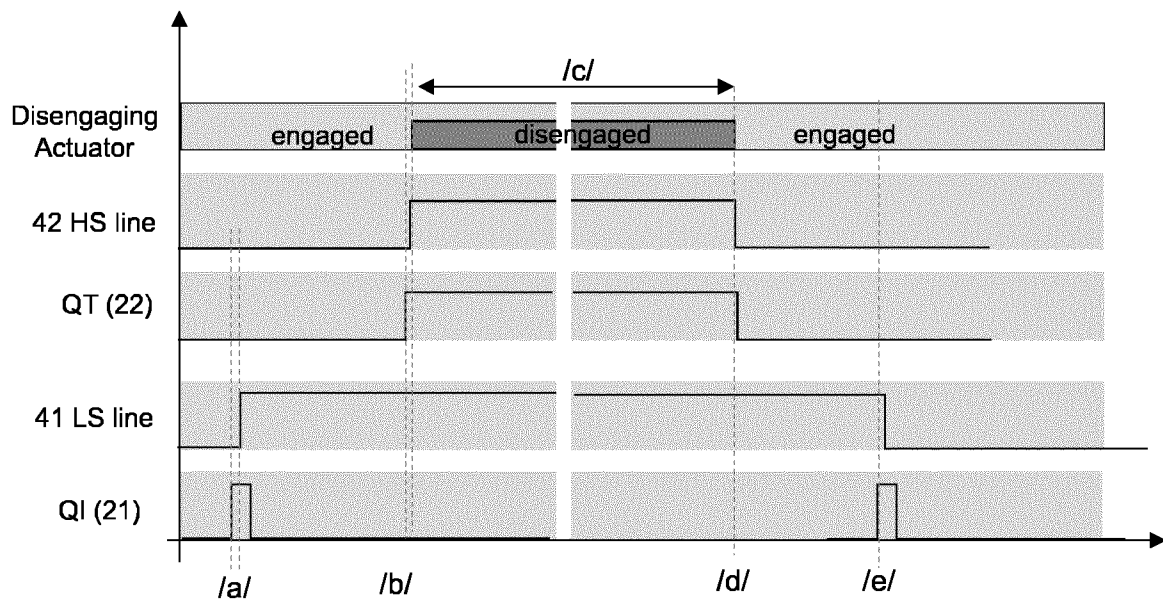

FIG. 5

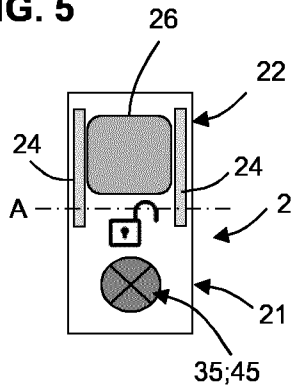

FIG. 6A

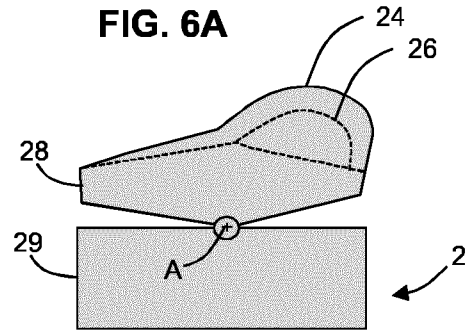

FIG. 6B

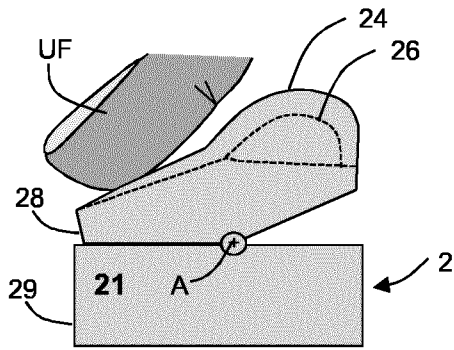

FIG. 6C

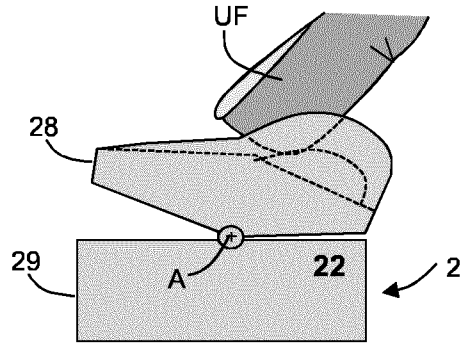
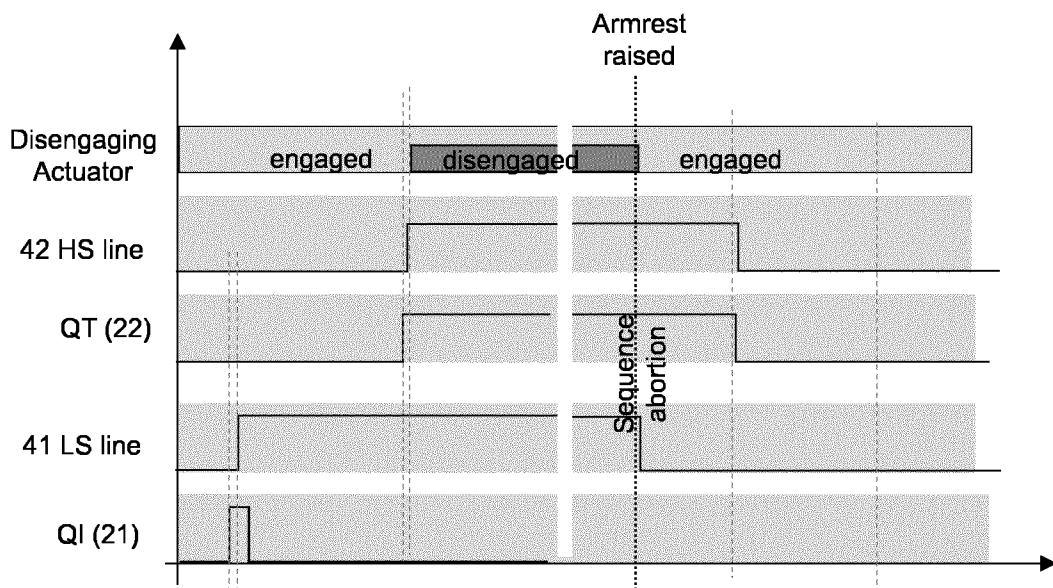

FIG. 7



INTERNATIONAL SEARCH REPORT

International application No
PCT/EP2018/067306

A. CLASSIFICATION OF SUBJECT MATTER
INV. E02F9/24 F15B20/00 E02F3/36
ADD.
 According to International Patent Classification (IPC) or to both national classification and IPC

B. FIELDS SEARCHED
 Minimum documentation searched (classification system followed by classification symbols)
E02F F15D F15B

Documentation searched other than minimum documentation to the extent that such documents are included in the fields searched

Electronic data base consulted during the international search (name of data base and, where practicable, search terms used)
EPO-Internal , WPI Data

C. DOCUMENTS CONSIDERED TO BE RELEVANT

Category*	Citation of document, with indication, where appropriate, of the relevant passages	Relevant to claim No.
A	US 9 970 177 B2 (DEERE & CO [US]) 15 May 2018 (2018-05-15) column 6, line 44 - column 7, line 47; figure 8	1-15
A	----- WO 2015/155232 A1 (CATERPILLAR SARL [CH]) 15 October 2015 (2015-10-15) paragraph [0035] - paragraph [0043]; figure 1; table 1	1-15
A	----- US 2004/244575 A1 (FATEMI RAY S [US] ET AL) 9 December 2004 (2004-12-09) paragraph [0035] - paragraph [0038]; figure 1C paragraph [0053] - paragraph [0058]; figure 2B -----	1-15

Further documents are listed in the continuation of Box C.

See patent family annex.

* Special categories of cited documents :

- "A" document defining the general state of the art which is not considered to be of particular relevance
- E " earlier application or patent but published on or after the international filing date
- "L" document which may throw doubts on priority claim(s) or which is cited to establish the publication date of another citation or other special reason (as specified)
- "O" document referring to an oral disclosure, use, exhibition or other means
- "P" document published prior to the international filing date but later than the priority date claimed

- "T" later document published after the international filing date or priority date and not in conflict with the application but cited to understand the principle or theory underlying the invention
- "X" document of particular relevance; the claimed invention cannot be considered novel or cannot be considered to involve an inventive step when the document is taken alone
- "Y" document of particular relevance; the claimed invention cannot be considered to involve an inventive step when the document is combined with one or more other such documents, such combination being obvious to a person skilled in the art
- "&" document member of the same patent family

Date of the actual completion of the international search 15 February 2019	Date of mailing of the international search report 28/02/2019
--	---

Name and mailing address of the ISA/ European Patent Office, P.B. 5818 Patentlaan 2 NL - 2280 HV Rijswijk Tel. (+31-70) 340-2040, Fax: (+31-70) 340-3016	Authorized officer Clarke, Alister
--	--

INTERNATIONAL SEARCH REPORT

Information on patent family members

International application No

PCT/EP2018/067306

Patent document cited in search report	Publication date	Patent family member(s)	Publication date
US 9970177	B2	15-05-2018	NONE
WO 2015155232	A1	15-10-2015	CN 106133249 A 16-11-2016
			EP 3129559 A1 15-02-2017
			JP 6176666 B2 09-08-2017
			JP 2015200104 A 12-11-2015
			KR 20160142848 A 13-12-2016
			US 2017030047 A1 02-02-2017
			WO 2015155232 A1 15-10-2015
US 2004244575	A1	09-12-2004	NONE