

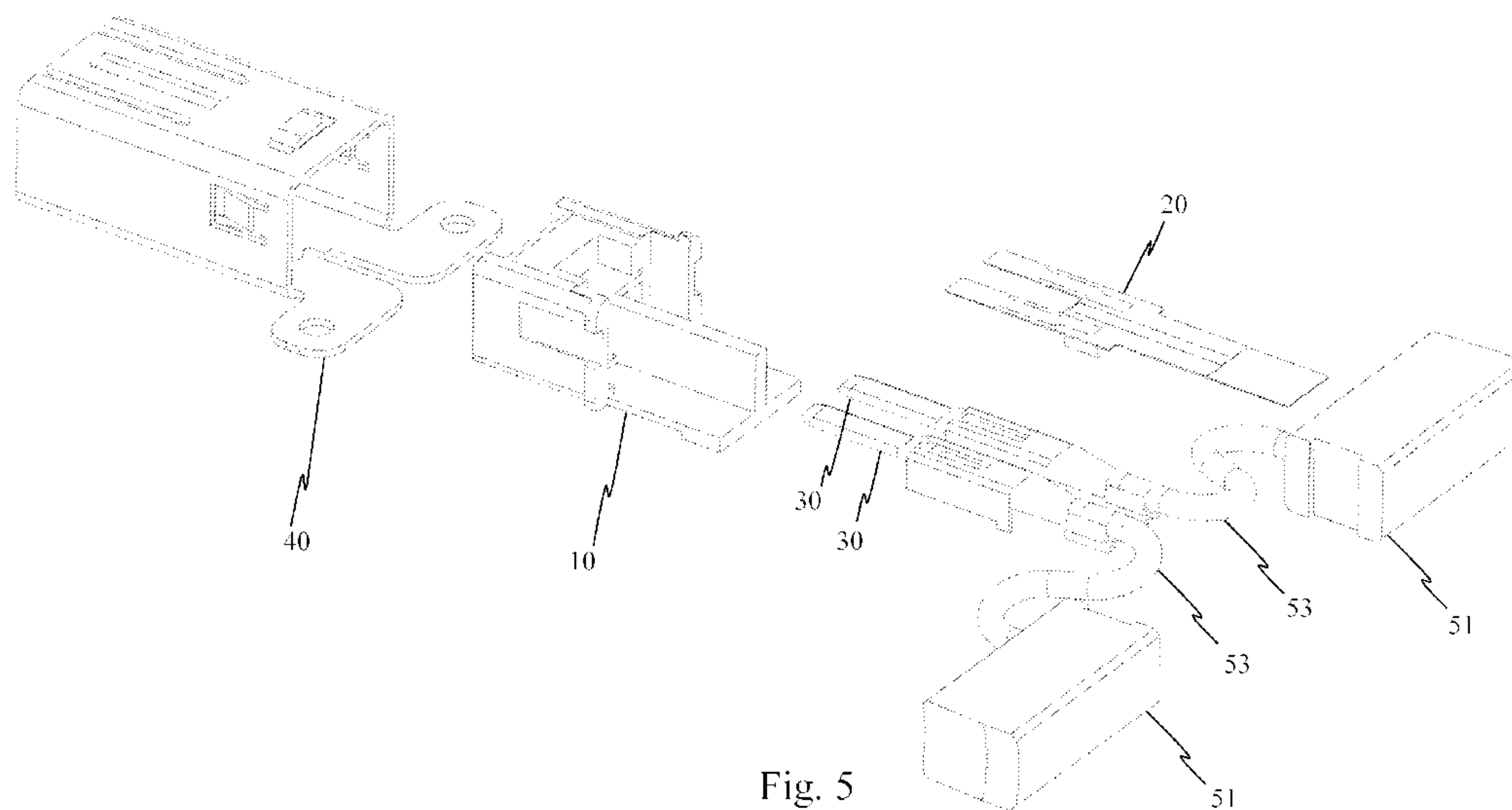

(86) Date de dépôt PCT/PCT Filing Date: 2013/07/15
 (87) Date publication PCT/PCT Publication Date: 2014/01/16
 (85) Entrée phase nationale/National Entry: 2015/01/12
 (86) N° demande PCT/PCT Application No.: US 2013/050507
 (87) N° publication PCT/PCT Publication No.: 2014/012097
 (30) Priorité/Priority: 2012/07/13 (US13/549,139)

(51) Cl.Int./Int.Cl. *H01R 13/658* (2011.01),
H01R 13/11 (2006.01)
 (71) Demandeur/Applicant:
ALLIED MOTION TECHNOLOGIES INC., US
 (72) Inventeur/Inventor:
COLWELL, ROBERT, US
 (74) Agent: FINLAYSON & SINGLEHURST

(54) Titre : **CONNECTEUR ELECTRIQUE ET SON PROCÉDE D'ASSEMBLAGE**
 (54) Title: **ELECTRICAL CONNECTOR AND METHOD OF ASSEMBLING SAME**



(57) **Abrégé/Abstract:**

An electrical connector and method assembling the same. A device of the present invention may comprise a connector frame, a flexible printed circuit board connected to the connector frame, a filter mounted to the flexible printed circuit board; and at least one

(57) **Abrégé(suite)/Abstract(continued):**

terminal mounted to the flexible printed circuit board and in electrical communication with the filter. A method of the present invention to assemble an electrical connector may comprise the steps of: providing a flexible printed circuit board having two conductive pads and a filter in electrical communication with the two conductive pads; connecting each conductive pad to a corresponding terminal; inserting each terminal into corresponding holders in a connector frame; placing the flexible printed circuit board in a curved pathway of the connector frame to form a connector subassembly; and inserting the connector subassembly into a connector housing. The filter may have three electrical connections, two are connected to the terminals and one is connected to ground.

(12) INTERNATIONAL APPLICATION PUBLISHED UNDER THE PATENT COOPERATION TREATY (PCT)

(19) World Intellectual Property
Organization
International Bureau

WIPO | PCT

(10) International Publication Number
WO 2014/012097 A1(43) International Publication Date
16 January 2014 (16.01.2014)

- (51) **International Patent Classification:**
H01R 13/658 (2011.01) *H01R 13/11* (2006.01)
- (21) **International Application Number:**
PCT/US2013/050507
- (22) **International Filing Date:**
15 July 2013 (15.07.2013)
- (25) **Filing Language:** English
- (26) **Publication Language:** English
- (30) **Priority Data:**
13/549,139 13 July 2012 (13.07.2012) US
- (71) **Applicant:** ALLIED MOTION TECHNOLOGIES INC.
[US/US]; 23 Inverness Way E, Suite 150, Englewood, CO
80112-5711 (US).
- (72) **Inventor:** COLWELL, Robert; 261 Catherine Drive,
Owosso, MI 48867 (US).
- (74) **Agents:** CUTAIA, Alfonzo, I. et al.; Hodgson Russ LLP,
The Guaranty Building, 140 Pearl Street, Suite 100, Buf-
falo, NY 14202-4040 (US).

- (81) **Designated States** (*unless otherwise indicated, for every kind of national protection available*): AE, AG, AL, AM, AO, AT, AU, AZ, BA, BB, BG, BH, BN, BR, BW, BY, BZ, CA, CH, CL, CN, CO, CR, CU, CZ, DE, DK, DM, DO, DZ, EC, EE, EG, ES, FI, GB, GD, GE, GH, GM, GT, HN, HR, HU, ID, IL, IN, IS, JP, KE, KG, KN, KP, KR, KZ, LA, LC, LK, LR, LS, LT, LU, LY, MA, MD, ME, MG, MK, MN, MW, MX, MY, MZ, NA, NG, NI, NO, NZ, OM, PA, PE, PG, PH, PL, PT, QA, RO, RS, RU, RW, SC, SD, SE, SG, SK, SL, SM, ST, SV, SY, TH, TJ, TM, TN, TR, TT, TZ, UA, UG, US, UZ, VC, VN, ZA, ZM, ZW.
- (84) **Designated States** (*unless otherwise indicated, for every kind of regional protection available*): ARIPO (BW, GH, GM, KE, LR, LS, MW, MZ, NA, RW, SD, SL, SZ, TZ, UG, ZM, ZW), Eurasian (AM, AZ, BY, KG, KZ, RU, TJ, TM), European (AL, AT, BE, BG, CH, CY, CZ, DE, DK, EE, ES, FI, FR, GB, GR, HR, HU, IE, IS, IT, LT, LU, LV, MC, MK, MT, NL, NO, PL, PT, RO, RS, SE, SI, SK, SM, TR), OAPI (BF, BJ, CF, CG, CI, CM, GA, GN, GQ, GW, KM, ML, MR, NE, SN, TD, TG).

Published:

— with international search report (Art. 21(3))

(54) **Title:** ELECTRICAL CONNECTOR AND METHOD OF ASSEMBLING SAME

Fig. 5

(57) **Abstract:** An electrical connector and method assembling the same. A device of the present invention may comprise a connector frame, a flexible printed circuit board connected to the connector frame, a filter mounted to the flexible printed circuit board; and at least one terminal mounted to the flexible printed circuit board and in electrical communication with the filter. A method of the present invention to assemble an electrical connector may comprise the steps of: providing a flexible printed circuit board having two conductive pads and a filter in electrical communication with the two conductive pads; connecting each conductive pad to a corresponding terminal; inserting each terminal into corresponding holders in a connector frame; placing the flexible printed circuit board in a curved pathway of the connector frame to form a connector subassembly; and inserting the connector subassembly into a connector housing. The filter may have three electrical connections, two are connected to the terminals and one is connected to ground.

WO 2014/012097 A1

ELECTRICAL CONNECTOR AND METHOD OF ASSEMBLING SAME

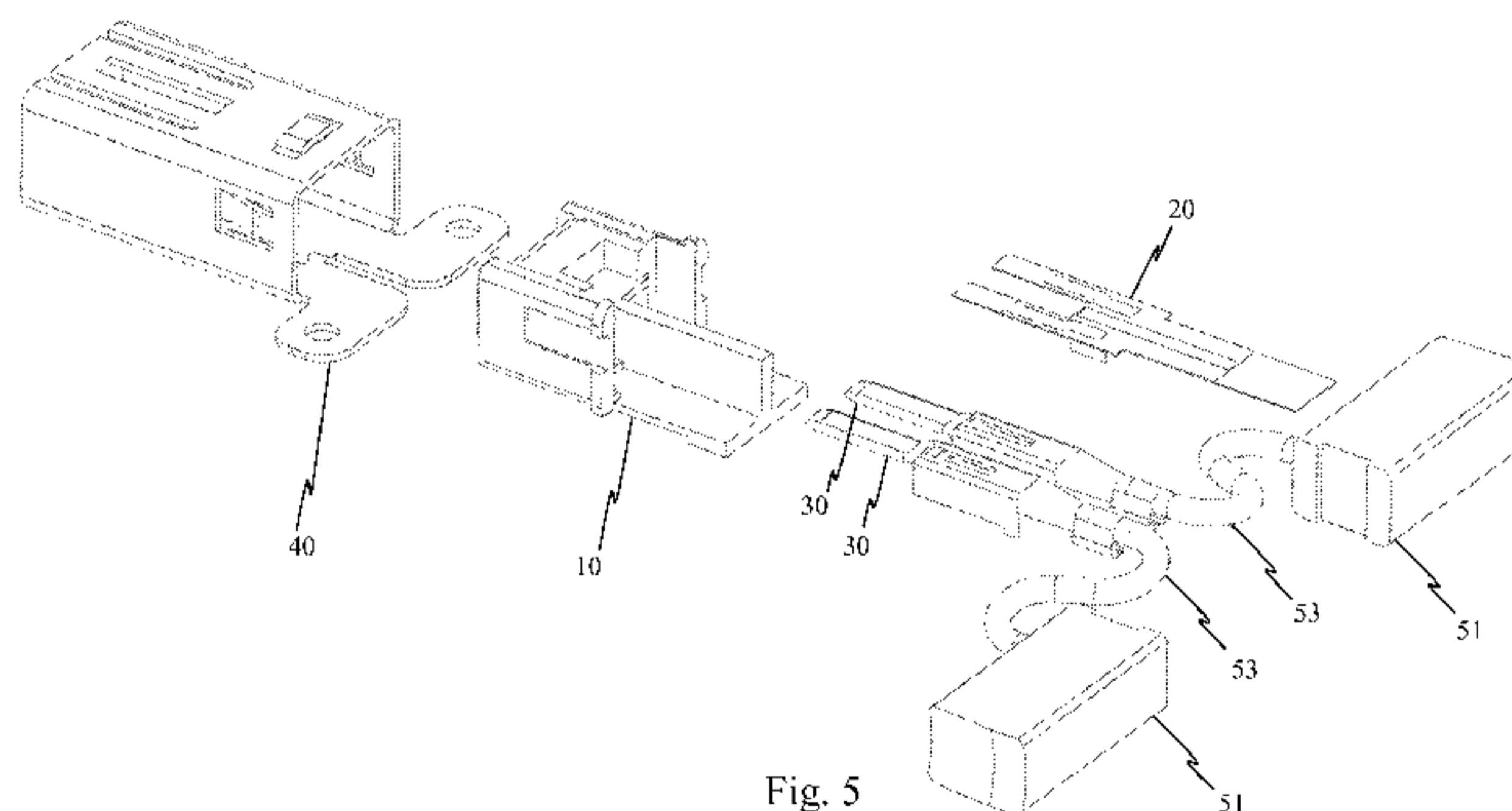
Field of the Invention

[0001] The present invention relates to an electrical connector, for example an
5 electrical connector for an electric machine.

Background of the Invention

[0002] Certain electric systems include electric machines, such as electrical motors,
that can create significant amounts of electrical noise, which can adversely affect other, more
sensitive components. In order to reduce this electrical noise, filters are often added to these
10 systems. And, the placement of such filters within the system is an important factor to the
effectiveness of electrical noise reduction. For example, in an system with an electrical
motor, it may be preferable to place the filter close to the point where the lead wires exit the
motor housing.

[0003] Many systems include standardized electric motors that have electrical
15 connectors. Such electrical connectors allow these motors to be more easily “plugged-in” to
the system. In this way, systems with electrical motors can be more easily designed using
readily-available, modular components, and those modular components can be more readily
replaced, using the removable electrical connectors, should the need arise.

[0004] As previously stated, it is often desirable to include a noise filter when an
20 electric motor is used in a system. Where the electric motor has a modular design with a
removable electrical connector, it is convenient to include the filter as part of the motor
module. Considering the design goal of locating the filter closer to the lead wires and/or
electrical connector, previous motor designs have included the filter within the electrical
connector.

25 [0005] While the components of many systems are subjected to significant stresses,
electrical connectors are uniquely susceptible due to the non-permanent nature of their

connection to a mating connector. Furthermore, the act of forming and breaking the mating connections creates additional stresses that electrical connectors must be able to withstand.

[0006] Previous attempts at integrating filters in connectors have used rigid printed circuit boards and/or overmolding. Overmolding is an injection molding process where one
5 material (usually an elastomeric material) is molded “over” a secondary, rigid substrate material (such as a rigid printed circuit board).

[0007] The rigid printed circuit board and overmolding techniques were seen to be advantageous for electrical connectors because rigid bodies may be able to withstand environmental stresses while maintaining a consistent electrical connection in a system. For
10 example, some electrical connectors are used with sensors in close proximity to an engine’s combustion chambers. Previous electrical connector designs have utilized rigid components, such as rigid printed circuit boards (“PCBs”) to reduce and withstand mechanical and physical stresses, shock, vibration, and various thermal conditions.

[0008] However, the use of overmolding has shortcomings. First, the overmolding
15 process is costly and time consuming as it requires two sequential molds. Furthermore, during the overmolding process, the substrate material must be stationary. Otherwise, it is difficult to repeatedly overmold substrates with a consistent outcome. As such, when overmolding flexible components, additional measures must be taken to ensure that the substrate does not move during the overmolding process. These additional measures increase
20 the complexity, and therefore, the cost to produce electrical connectors. Also, filters can be bulky and susceptible to damage, especially if exposed to high-temperature assembly techniques such as overmolding.

[0009] Rigid components, such as PCBs, can be difficult to design into small form-factor housings (e.g., electrical connectors). There is generally a trade-off between the ability
25 of a rigid component to fit into a small space and the ability of that component to be easily assembled. This trade-off creates a more costly and/or complex device.

[0010] Therefore, it is difficult to place filters in close proximity to the electrical connector and/or lead wires without increasing the cost and complexity of the connector.

Summary of the Invention

[0011] The invention provides an electrical connector device and a method for
5 making the electrical connector device. For example, the electrical connector device may be used with an electrical machine. The present invention solves the problems found in the prior art by mounting a filter to a flexible printed circuit board, thereby removing the need for overmolding, and placing the filter as close as possible to the electrical connector. Further, the flexibility of the flexible printed circuit board provides the unexpected result of
10 simplifying assembly of the electrical connector while reducing stress on the electrical contacts between the flexible printed circuit board and a terminal.

[0012] Here, “terminal” refers to a conductive member that interfaces with the mating counterpart of the electrical connector. For example, the terminal may be a pin, blade, cavity, or slit. The terminal need not be encompassed by its counterpart, but may only abut the
15 counterpart so as to make an electrical connection. For example, a terminal may be the prongs and socket on a standard electrical plug, or the metallic contacts of a USB connector and slot.

[0013] The present invention may be embodied as an electrical connector comprising a connector frame, a flexible printed circuit board connected to the connector frame, a filter
20 mounted to the flexible printed circuit board, and at least one terminal mounted to the flexible printed circuit board and in electrical communication with the filter. The electrical connector may further comprise a connector housing configured such that the connector frame is substantially disposed within the connector housing.

[0014] In one embodiment, the filter may be in electrical communication with a
25 common ground by way of the connector housing. The filter may comprise a multilayer ceramic chip capacitor, or discrete components (*e.g.*, inductors, capacitors, resistors, etc.).

[0015] In one embodiment, the flexible printed circuit board may be disposed in a curved pathway of the connector frame. The flexible printed circuit board may also have a number of leg portions corresponding with the number of terminals in the electrical connector. The at least one terminal may be mounted to the flexible printed circuit board at
5 the corresponding leg portion.

[0016] In another embodiment, the connector frame may have a projection and the flexible printed circuit board may have an aperture capable of alignment with the connector frame's projection. Here, "projection" may refer to any retention features or guiding features (such as a pin or nub) that extend from a surface of the connector frame in order to align or
10 retain the flexible printed circuit board. "Aperture" may refer to any guiding feature (such as a hole or cut-out) present in the flexible printed circuit board in order to align the flexible printed circuit board with the connector frame's projection(s).

[0017] The invention may also be embodied as a method of making an electrical connector. One such method comprises the steps of: providing a flexible printed circuit board
15 having two conductive pads and a filter in electrical communication with the two conductive pads; connecting each conductive pad to a corresponding terminal; inserting each terminal into corresponding holders in a connector frame; placing the flexible printed circuit board in a curved pathway of the connector frame to form a connector subassembly; and inserting the connector subassembly into a connector housing.

20 [0018] In one embodiment of the method, the step of placing the flexible printed circuit board in a curved pathway of the connector frame further comprises the sub-step of inserting a projection of the connector frame into an aperture of the flexible printed circuit board.

[0019] In another embodiment of the method, the housing is electrically conductive
25 and the method further comprises the step of electrically connecting the filter to the housing. The connecting steps may be performed by soldering.

[0020] In one embodiment, the method further comprises the step of electrically connecting leads to the at least two terminals.

Brief Description of the Drawings

[0021] For a fuller understanding of the nature and objects of the invention, reference should be made to the accompanying drawings and the subsequent description. Briefly, the drawings are:

Figures 1A and 1B show multiple perspective views of a connector frame according to an exemplary embodiment of the invention;

Figures 2A and 2B show multiple perspective views of a printed circuit board having a filter according to an exemplary embodiment of the invention;

Figure 3 shows a terminal according to an exemplary embodiment of the invention;

Figures 4A and 4B show multiple perspective views of a connector housing according to an exemplary embodiment of the invention;

Figure 5 shows an exploded view of an assembled electrical connector according to an exemplary embodiment of the invention;

Figures 6A and 6B show multiple perspective views of an assembled electrical connector according to an exemplary embodiment of the invention;

Figures 7A and 7B show multiple perspective views of an assembled electrical connector mounted to the base of an electric machine according to an exemplary embodiment of the invention;

Figure 8 shows a view of an electrical connector integrated into an electrical motor according to an embodiment of the invention;

Figure 9 shows the step of connecting the conductive pad of a flexible printed circuit board to a corresponding terminal according to an embodiment of the invention;

Figure 10 shows the step of inserting each terminal into corresponding holders in a connector frame according to an embodiment of the invention;

Figure 11 shows the step of placing the flexible printed circuit board into a curved pathway of the connector frame and inserting the connector subassembly into a connector housing according to an embodiment of the invention;

Figure 12 shows an assembled electrical connector according to an embodiment of the present invention;

Figures 13A shows a wireframe cross-section and 13B shows a shaded cross-section of the assembled electrical connector according to an embodiment of the invention; and

Figure 14 is a flowchart showing a method of making an electrical connector according to an embodiment of the invention.

Further Description of the Invention

[0022] The present invention may be embodied as an electrical connector for an electrical machine. As used herein, an “electrical machine” may refer to any device, including but not limited to, devices that produce or require electrical energy, transmit data using electrical energy, convert mechanical energy to electrical energy, convert electrical energy to mechanical energy, or changes alternating current from one voltage level to a different voltage level. One example of an electrical machine is an electric motor.

[0023] The connector frame may be formed from a non-conductive, material such as a plastic. The connector frame may be rigid or semi-rigid. The connector frame may be formed to accept counterpart mating terminals. The connector frame may also be formed to isolate various electrical components, for example, by providing a non-conductive partition between ground and powered portions of the connector.

[0024] In another embodiment, the connector frame is formed such that the other components of the electrical connector can snap into place for easy assembly. For example, the connector frame may have small tabs that align and guide other components of the electrical connector.

[0025] The flexible printed circuit board is connected to the connector frame. The flexible printed circuit board is formed such that it can conform to a desired shape or bend around features of the connector frame. In one embodiment, the flexible printed circuit board is a single-sided flex circuit having a single conductor layer made of either a metal or
5 conductive (metal filled) polymer on a flexible dielectric film. Holes may be formed in the base film to allow component leads to pass through for interconnection, normally by soldering. Components may also be surface mounted to a flexible printed circuit board. Single sided flex circuits may be fabricated with or without protective coatings as cover layers or cover coats.

10 [0026] The flexible printed circuit board may also have one or more mounting points at which other components can be electrically connected. The mounting points may be electrically conductive areas such as pads or contacts. The flexible printed circuit board may be disposed in a curved pathway of the connector frame. In one embodiment, the flexible printed circuit board is capable of being folded and threaded through apertures in the
15 connector frame.

[0027] In another embodiment, the flexible printed circuit board may have a number of leg portions corresponding with the number of terminals in the connector. The leg portions may be tabs extending from the printed circuit board. The at least one terminal may be mounted or electrically connected to the flexible printed circuit board at the corresponding
20 leg portion. In this way, only one terminal would be mounted or electrically connected to each leg portion. In other embodiments, multiple terminals may be mounted or electrically connected to a single leg portion.

[0028] The filter may be mounted to the flexible printed circuit board through soldering or any other method that maintains an electrical connection between the filter and
25 the flexible printed circuit board (*e.g.*, clamping). The filter may comprise multiple discrete components (*e.g.*, inductors, capacitors, resistors, etc.) or a single component package. The filter may also be a multilayer ceramic chip capacitor. In one embodiment, the filter is an

X2Y® capacitor available from X2Y Attenuators LLC, 2730-B West 21st Street, Erie, PA 16506-2972.

[0029] In another embodiment, the flexible printed circuit board has a third
conductive pad which is electrically connected to the motor housing and eventually to
5 ground. The filter may also have three electrical connections, each connection corresponding
to one of the flexible printed circuit board's conductive pads. For example, two of the filter's
electrical connections are connected to the terminals, and one of the filter's electrical
connections is connected to ground. In one embodiment, a capacitor is placed between a first
terminal and ground, a second terminal and ground, and the first terminal and the second
10 terminal.

[0030] At least one terminal may be mounted to the flexible printed circuit board. The
at least one terminal may be formed from a conductive substance, such as a metal. In one
embodiment, the terminals may be "male" or "female." The contacts may be configured to
insert or receive, a mated terminal. In another embodiment, the terminal may have two ends,
15 the first end configured to mate with another terminal, and the second end configured to be
electrically connected to a lead (*e.g.*, wire, electrical connection, etc.) from the electrical
machine. The second end of each terminal may be connected (*e.g.*, soldered) to a mounting
point on the flexible printed circuit board. The terminal may also be configured with features
that align and hold the terminal at least partially within the connector frame.

[0031] The at least one terminal is in electrical communication with the filter. The
electrical communication may be indirect (*e.g.*, where other components, such as wires or the
flexible printed circuit board, electrically connect the terminal to the filter). The method may
also comprise the step of electrically connecting lead wires to the at least one terminals.

[0032] In another embodiment, the electrical connector may further comprise a
25 connector housing. The connector housing may be formed from a conductive or non-
conductive material. The housing may be configured such that the connector frame can be
substantially disposed within the connector housing. For example, portions of the connector

frame, or a terminal, may extend beyond the connector housing. The connector housing may not enclose sections of the connector frame that lead to the electrical machine.

[0033] The housing may have features that align the connector frame within the housing or hold the connector frame into the housing. For example, the connector frame may have a projection such as a pin or notch, and the connector housing may have an aperture, or
5 other physical feature, capable of alignment with the projection of the connector frame.

[0034] In one embodiment, the connector housing is formed from a conductive material, such as metal, and is connected to a common ground. For example, the housing can be connected to a common ground when the electrical connector is mated, or through a
10 common ground in the flexible printed circuit board. The filter may also be in electrical communication with the common ground by way of the connector housing. For example, the filter may be electrically connected to a trace on the flexible printed circuit board, the trace electrically connected to the connector housing, and the connector housing electrically
15 electrically connected to a common ground. Through this series of electrical connections, the filter is electrically connected to ground.

[0035] In some embodiments, two or more common grounds may be connected together to create a Faraday cage capable of reducing electrical noise and interference. For example a Faraday cage may be formed around a connected electrical connector, thereby reducing or eliminated electromagnetic interference propagated or emitted by the electrical
20 connector.

[0036] The present invention may also be embodied as a method of making an electrical connector. The method may comprise the step of providing a flexible printed circuit board having two conductive pads and a filter in electrical communication with the two conductive pads. The filter may be in direct electrical communication with the two
25 conductive pads, or indirect communication through traces on the PCB.

[0037] The method may also comprise the step of connecting each conductive pad to a corresponding terminal. The connecting step may be performed by soldering a terminal to a

single conductive pad. In another embodiment, the terminal may be clamped, or otherwise connected to the conductive pad. A conductive pad may also be connected to more than one terminal.

[0038] The method may also comprise the step of inserting each terminal into
5 corresponding holders in a connector frame. The holders may be recesses in the connector frame configured to align the terminals such that they can be mated with another electrical connector. The holders may also be features in the connector frame configured to hold the terminal in place.

[0039] The method may also comprise the step of placing the flexible printed circuit
10 board in a curved pathway of the connector frame to form a connector subassembly. The flexible printed circuit board may be threaded through one or more apertures in the connector frame. In one embodiment, the step of placing the flexible printed circuit board in a curved pathway of the connector frame further comprises the sub-step of inserting a projection of the connector frame into an aperture of the flexible printed circuit board. The method may also
15 comprise the step of inserting the connector subassembly into a connector housing. The method may also comprise the step of electrically connecting the filter to the housing wherein the housing is electrically conductive.

[0040] EXEMPLARY EMBODIMENTS OF THE INVENTION

[0041] **Figures 1-8** show an assembled electrical connector device attached to an
20 electric machine according to one embodiment of the present invention. **Figures 1A** and **1B** show multiple perspective views of a connector frame **10**. The connector frame **10** is made from a non-conductive material, such as plastic. The connector frame may be molded or milled into its shape. In this embodiment, the connector frame has two holders **19** configured to accept one end of a terminal **30** (shown in **Fig. 3**). The holders **19** may be larger than
25 terminal **30** ends or of a similar size in order to maintain a friction fit. A divider **11** may be used to separate multiple terminals **30**. Here, the divider **11** is formed from the same piece of material as the rest of the connector frame **10**. The connector frame **10** also has a slot **12**

configured to accept the flexible printed circuit board **20** (shown in **Fig. 2**). The slot **12** may be of a similar size, or larger than, the printed circuit board **20**.

[0042] Filter cavity **13** is configured to be of a similar size and shape as the filter **21** (shown in **Fig. 2**) to simplify aligning the flexible printed circuit board **20** in the connector frame **10**. The filter cavity **13** may also be larger than the filter **21**. In this embodiment, retention surface **15** is formed into the connector frame **10** and is configured to hold the connector frame **10** in a connector housing **40** (shown in **Fig. 4**). For example, a retention element **45** (also shown in **Fig. 4**) may be provided that frictionally abuts with retention surface **15** or the lip surrounding retention surface **15**. The retention element **45** and the retention surface **15** are configured such that the connector housing **40** and the connector frame **10** snap together and become difficult to separate. Vertical guides **16** are configured to only permit the connector frame **10** to be inserted into the connector housing **40** at certain vertical alignments. The vertical guides **16** may make it easier for the connector frame **10** to be inserted into the connector housing **40** based on the tactile feedback provided during improper insertion (*i.e.*, when the vertical guides **16** make contact with features of the connector housing **40**.) Likewise, insertion guide **14** may also align the connector frame **10** with the connector housing **40**.

[0043] Horizontal terminal guides **18** and vertical terminal guides **17** serve a similar purpose, except with the terminal **30** instead of the connector housing **40**.

[0044] **Figures 2A** and **2B** show multiple perspective views of the flexible printed circuit board **20**. Here, the printed circuit board may be a double-sided flexible circuit having two conductive layers. The double-sided flexible circuit can be fabricated with a protective cover layer on both sides, and allows for a cross over connection between the conductive layers. In this way, conductive pads on one side of the flexible printed circuit board **20** may connect to other conductive pads on the opposite side of the flexible printed circuit board **20**.

[0045] Here, a filter **21** is mounted to the flexible printed circuit board **20**. The filter **21** may be configured to reduce the transmission or emission of electromagnetic interference

or, more specifically, radio frequency interference. The filter is mounted to at least
conductive filter mounts **22** and **23**. Conductive filter mount **22** is in electrical
communication with one conductive pad **22** of leg **26** of the flexible printed circuit board **20**.
For example, the filter mount **22** may be in electrical communication with a conductive pad
5 **22** through a trace in the flexible printed circuit board **20**. Conductive filter mount **23** acts as
an electrical pathway through portion **25** which terminates at conductive pad **27**. In **Figs. 2A**
and **2B**, conductive portions exposed to the environment are indicated by gray shading.

[0046] **Figure 3** shows a terminal **30**. The terminal **30** is formed from a conductive
material, such as metal. Here, the terminal **30** has a blade **34** configured to be inserted to a
10 corresponding female adapter. Other configurations of the blade **34** are possible, including
pins, slits, contacts, etc. The terminal **30** may have a retention portion **35** configured to guide
and secure the terminal **30** within the connector frame **10**. Terminal retention feature **33** is
configured to limit the insertion of the terminal **30** in the connector frame **10** such that the
terminal blade **34** is at a proper length. Lead end **32** has flanges **31** that can be used to crimp a
15 lead (not shown) into electrical communication with the terminal **30**. Here, the lead may be
placed in the lead end **32** between flanges **31**. Once in place, force is applied to flanges **31**
such that the flanges **31** secure and hold the lead.

[0047] **Figures 4A** and **4B** show multiple perspective views of a connector housing
40. Here, the connector housing **40** is constructed from a conductive material, such as metal.
20 However, in other embodiments, the connector housing **40** may be constructed from a non-
conductive material, such as plastic. The connector housing **40** has mounting flanges **41** that
can be used to mount the connector housing **40** (and the entire electrical connector) to an
electric machine. Apertures **42** are provided and configured to allow a fastener to secure the
connector housing **40** to an electric machine. Guide groove **43** is provided to ensure the
25 connector housing's **40** proper alignment with the electric machine. In this embodiment,
retention member **45** is provided, as discussed above, to help secure the connector frame **10**
to the connector housing **40**. Also provided are mating grooves **46** and mating aperture **47**.
The mating grooves **46** may be provided to help align a corresponding electrical connector

into electrical communication with the electrical connector of the invention. The mating aperture 47 may be configured to allow a mating flange to attach to the electrical connector, such that it cannot be removed by pulling the corresponding electrical connector away. For example, removal of the mated electrical connectors may require depressing the mating
5 flange (to remove the flange from aperture 47) while pulling the corresponding electrical connector away.

[0048] **Figure 5** shows an exploded view of an assembled electrical connector. Here, terminals 30 are crimped to leads 53 which are also electrically connected to brushes 51. The leads 53 may be an extension of brushes 51, or may be another electrically conductive
10 element such as a wire or filament. In this embodiment, brushes 51 are configured to manipulate an electric motor. **Figure 6** shows multiple perspective view of the assembled electrical connector 60.

[0049] **Figures 7A** and **7B** show multiple perspective views of an assembled electrical connector 60 mounted to the base of an electric machine. The base assembly 70 has
15 one or more alignment flanges 75 configured to align the base with the electric machine. The base assembly 70 also comprises brush mounts 71 that hold the brushes 51 in place and in proper alignment. The brush mounts 71 are affixed to the base by fasteners 72. Fasteners 73 also affix the electrical connector 60 to the base. The base may be constructed from a conductive material. The inside surfaces of the brush tube may have ribs 74 rather than flat
20 surfaces which contact the brush so that brush dust will be less likely to hang up the brush. The ribs 74 can also improve moldability and dimensional control. The resulting grooves in the two vertical sides may provide a place for a constant force brush spring.

[0050] **Figure 8** shows a view of an electrical connector integrated into an electrical motor 80. The electrical motor casing 81 surrounds the electrical motor and may also be
25 constructed as a conductive material. By constructing the connector housing 40, the base assembly 70 and the electrical motor casing 81 from conductive materials, these pieces may act in conjunction as a common ground surrounding the motor. By surrounding the motor,

these elements act as a Faraday cage, thus reducing (or eliminating) electromagnetic interference caused by an operating motor.

[0051] **Figures 9-12** show one embodiment of a method of making the electrical connector. **Figure 9** shows electrically connecting **90** the flexible printed circuit board **91** to the terminals **94**. The terminals are electrically connected (here, through crimping) to leads **92** and brushes **93**.

[0052] **Figure 10** shows folding **101** the flexible printed circuit board **91** for insertion **100** into the connector frame **102**. After insertion **100**, the flexible printed circuit board **91** is folded **111** once again above the connector frame **102**. The connector frame assembly **110** is then inserted **112** into the connector housing **113**. The final assembled electrical connector **120** is shown in **Figure 12**.

[0053] **Figures 13A and 13B** show, respectively, a wireframe cross-section and a shaded cross-section of the assembled electrical connector **130**. In this embodiment, connector housing **131** encloses terminals **132**, thereby protecting the terminals **132** from accidental contact. The flexible printed circuit board **133** is electrically connected to the terminals **132** and the electrical housing **131**. For example, the flexible printed circuit board **133** may be electrically connected through soldering. The connector frame **134** is also located substantially within the connector housing **131**.

[0054] The invention may also be embodied as a method **140** of making an electrical connector. The method **140** comprises the step of providing **141** a flexible printed circuit board having conductive pads and a filter. Conductive pad(s) are connected **143** to the terminal(s). Each terminal is inserted **144** into corresponding holders in a connector frame. The flexible printed circuit board is placed **145** in the connector frame to form a connector subassembly. The placement step **145** may comprise the substep of inserting **146** a projection of the connector frame into an aperture of the flexible printed circuit board. The connector subassembly is inserted **147** into a connector housing. In one embodiment, the filter is

electrically connected **148** to the connector housing, for example, through the flexible printed circuit board. In another embodiment, a lead is electrically connected **142** to the terminal.

[0055] Although the present invention has been described with respect to one or more particular embodiments, it will be understood that other embodiments of the present
5 invention may be made without departing from the spirit and scope of the present invention. Hence, the present invention is deemed limited only by the appended claims and the reasonable interpretation thereof.

What is claimed is:

1. An electrical connector for an electric machine, comprising:
 - a connector frame;
 - a flexible printed circuit board connected to the connector frame;
 - 5 a filter mounted to the flexible printed circuit board; and
 - at least one terminal mounted to the flexible printed circuit board and in electrical communication with the filter.
2. The electrical connector of claim 1, further comprising a connector housing configured such that the connector frame is substantially disposed within the connector housing.
- 10 3. The electrical connector of claim 2, wherein the filter is in electrical communication with a common ground by way of the connector housing.
4. The electrical connector of claim 1, wherein the connector frame has a projection and the flexible printed circuit board has an aperture capable of alignment with the projection of the connector frame.
- 15 5. The electrical connector of claim 1, wherein the filter is a three-node capacitor package.
6. The electrical connector of claim 1, wherein the flexible printed circuit board is disposed in a curved pathway of the connector frame.
7. The electrical connector of claim 1, wherein the flexible printed circuit board has a number of leg portions corresponding with the number of terminals.
- 20 8. The electrical connector of claim 7, wherein the at least one terminal is mounted to the flexible printed circuit board at the corresponding leg portion.
9. A method of making an electrical connector for an electric machine, the method comprising the steps of:
 - providing a flexible printed circuit board having two conductive pads and a filter in
 - 25 electrical communication with the two conductive pads;
 - connecting each conductive pad to a corresponding terminal;
 - inserting each terminal into corresponding holders in a connector frame;

placing the flexible printed circuit board in a curved pathway of the connector frame to
form a connector subassembly; and
inserting the connector subassembly into a connector housing.

10. The method of claim 9, wherein the step of placing the flexible printed circuit board in a
5 curved pathway of the connector frame further comprises the sub-step of inserting a
projection of the connector frame into an aperture of the flexible printed circuit board.
11. The method of claim 9, wherein the housing is electrically conductive and the method
further comprises the step of electrically connecting the filter to the housing.
12. The method of claim 9, further comprising the step of electrically connecting leads to the
10 at least two terminals.
13. The method of claim 9, wherein the connecting step is performed by soldering.

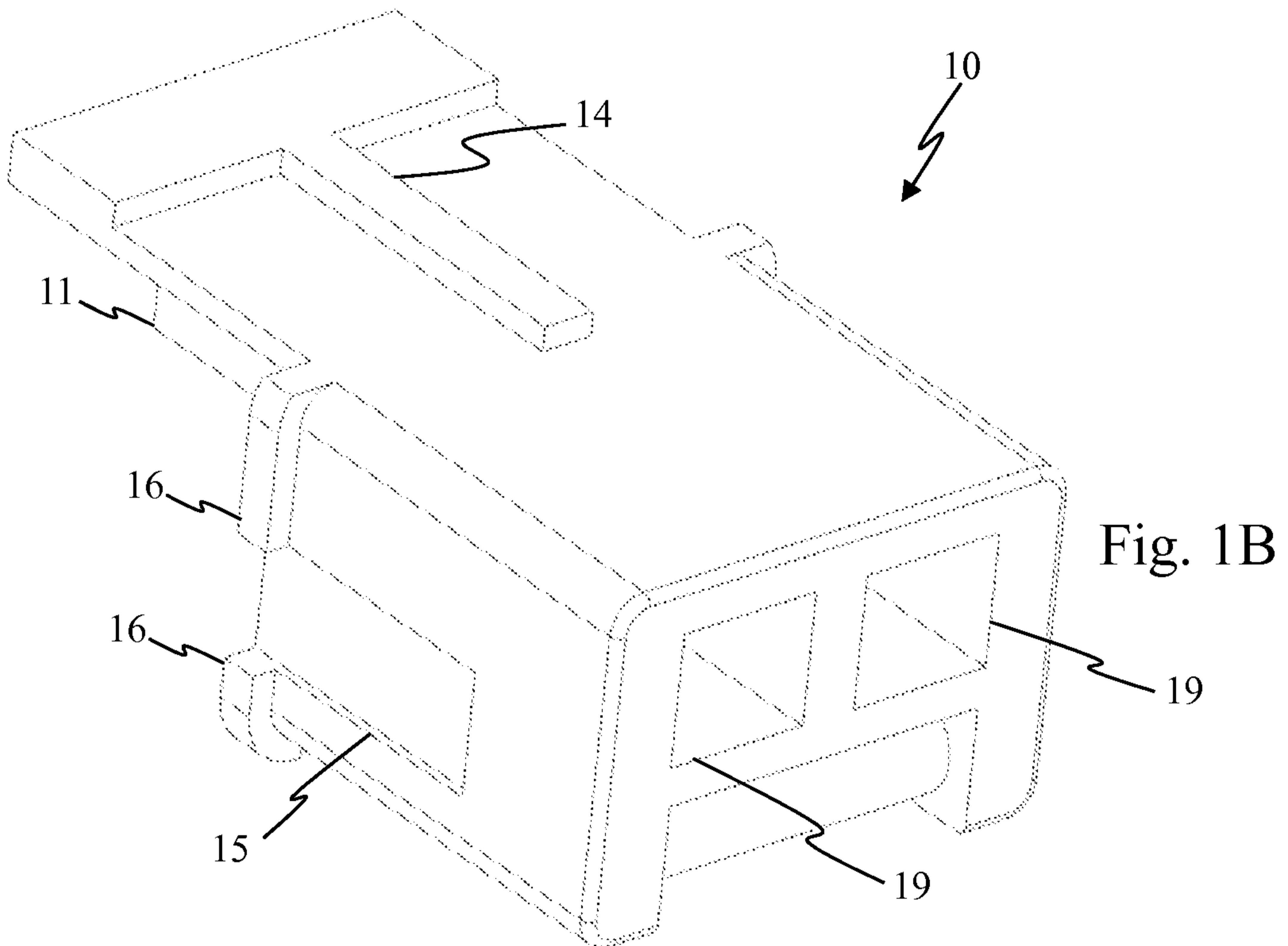
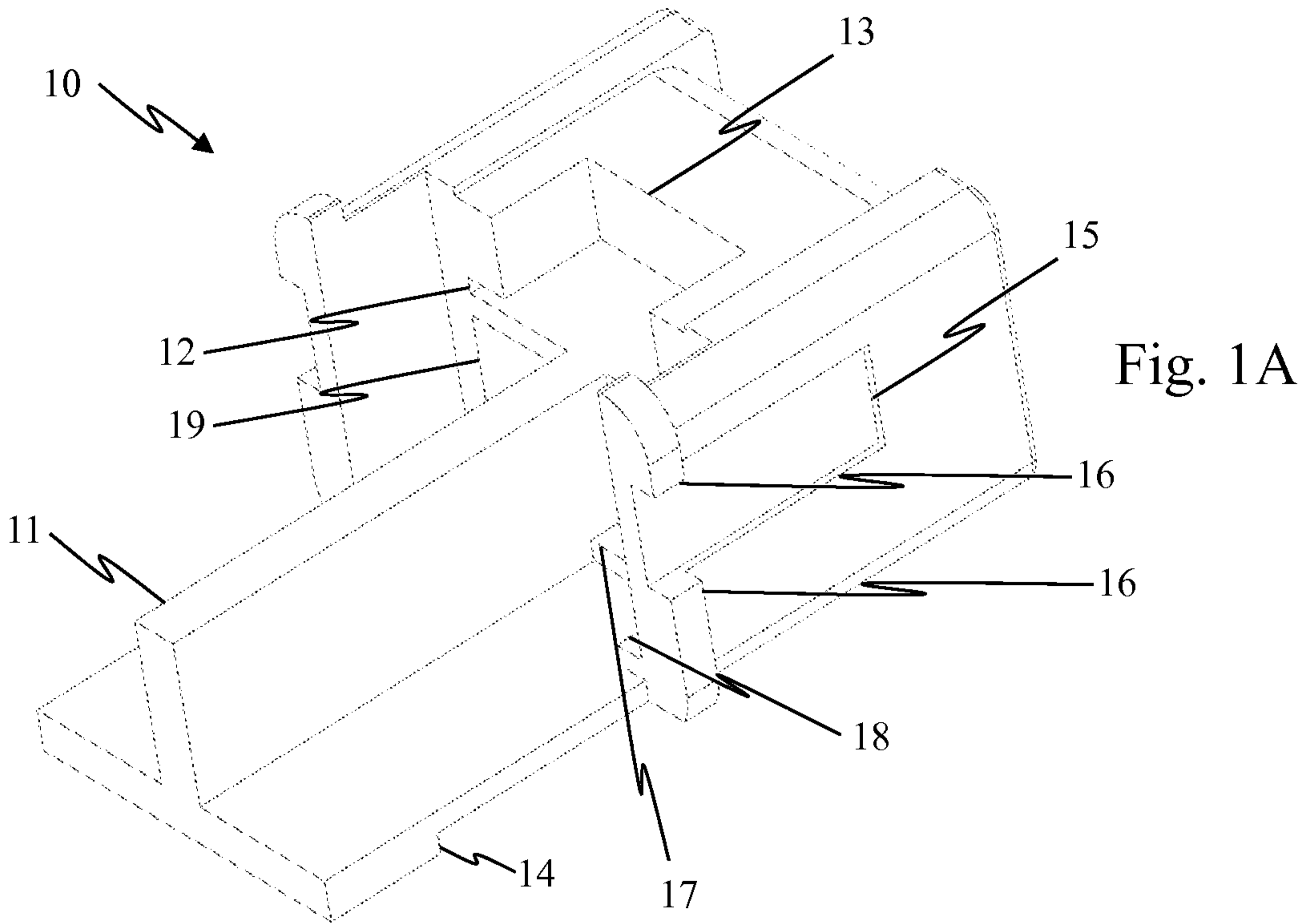

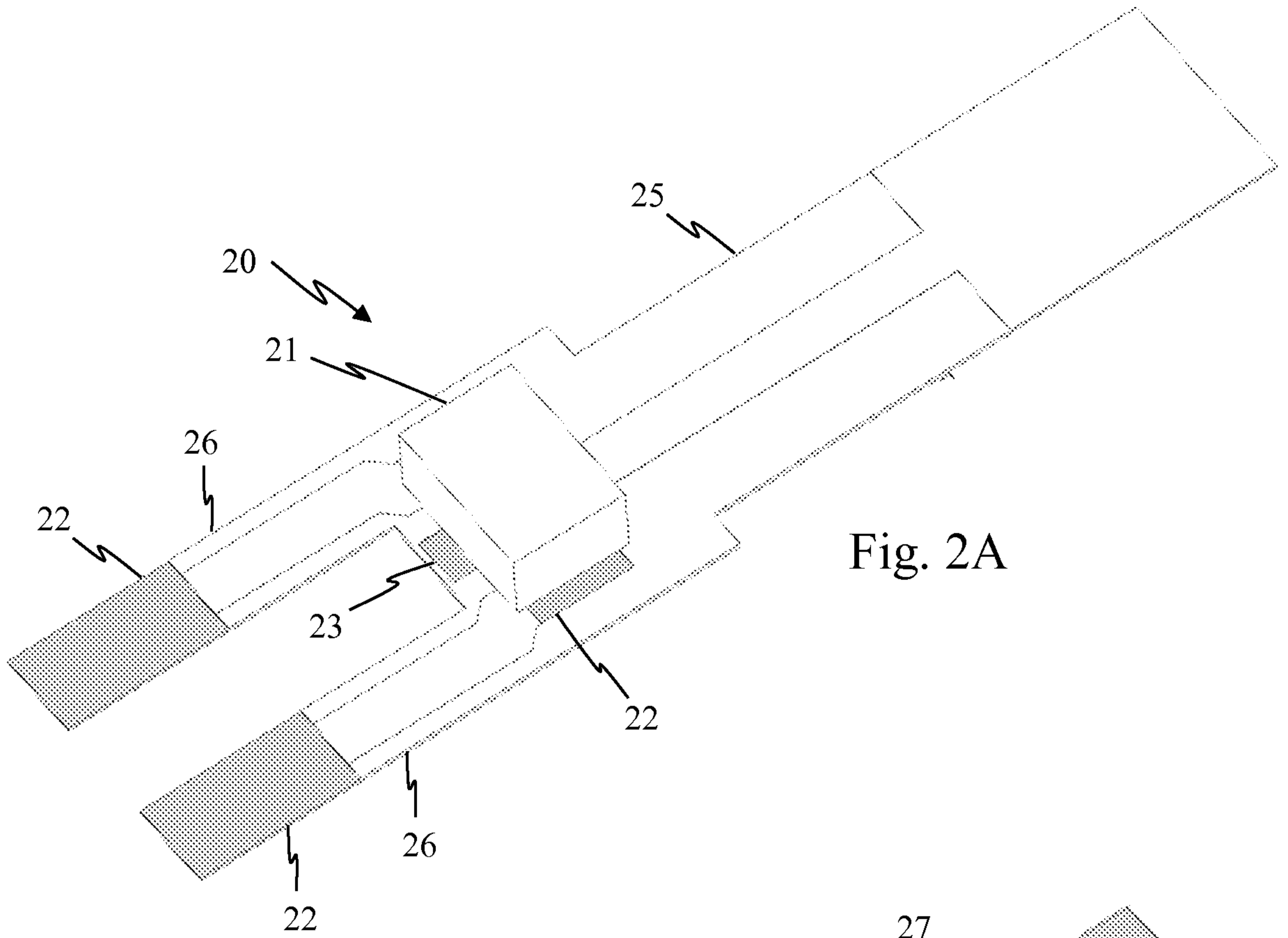

Fig. 2A

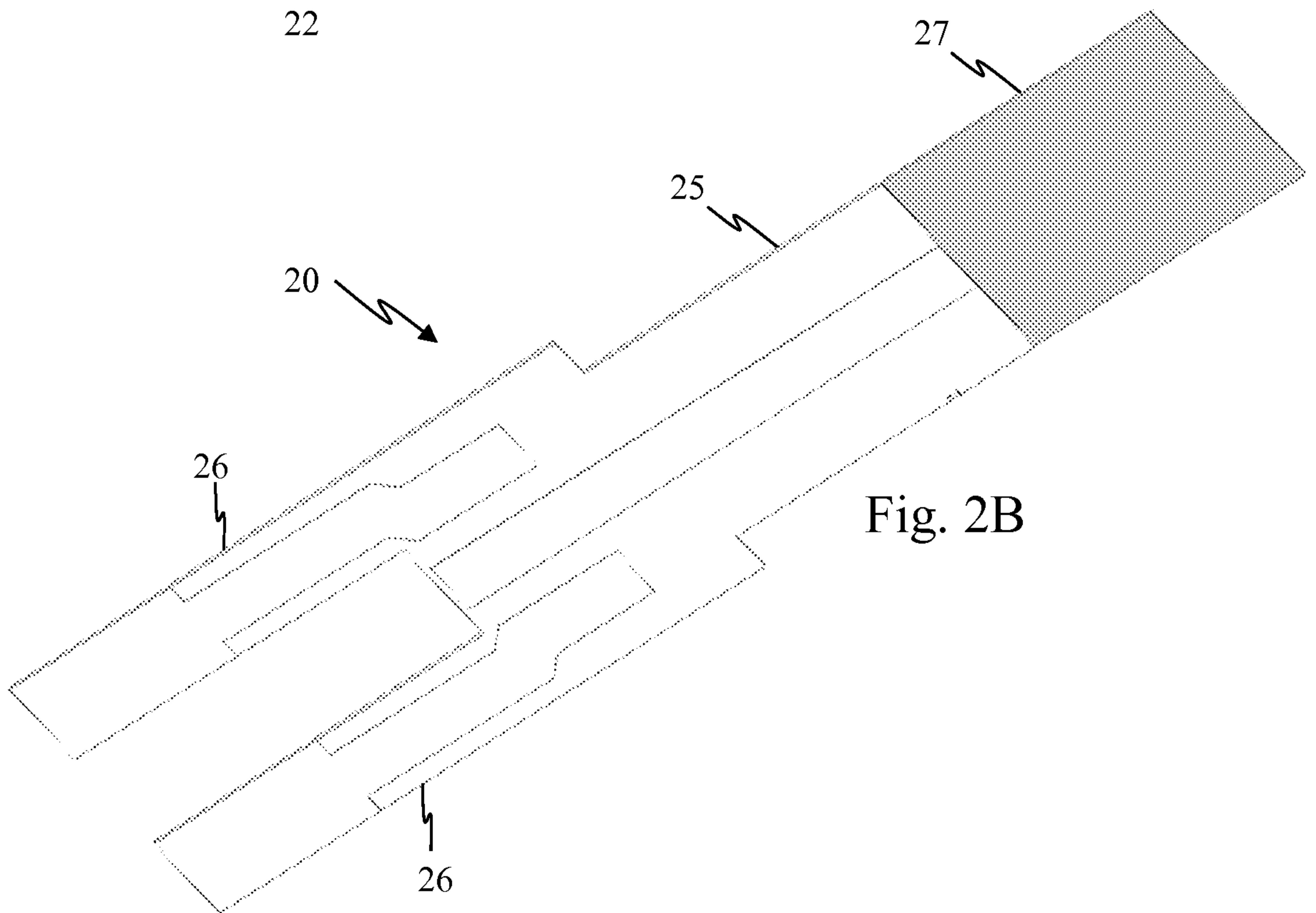

Fig. 2B

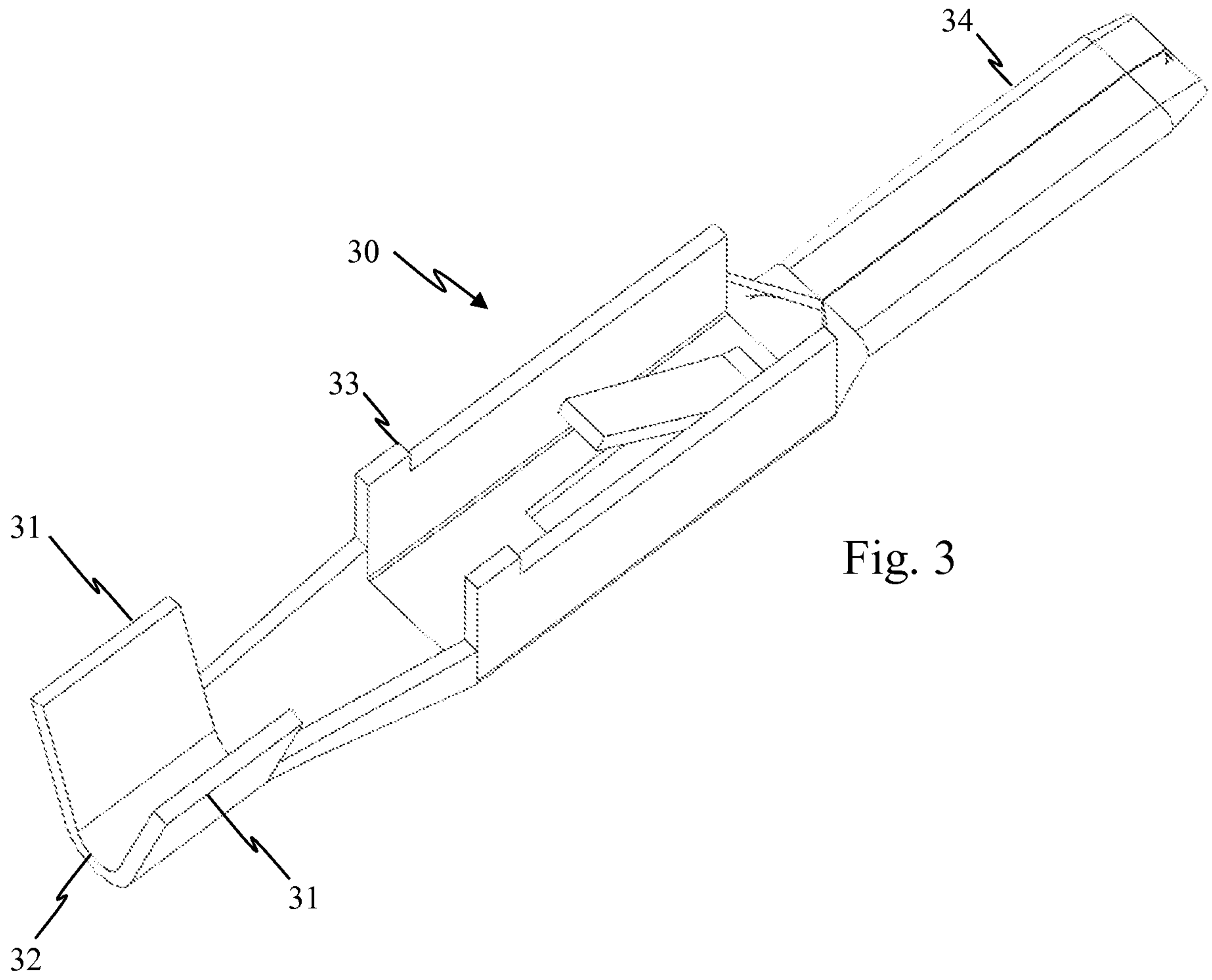

Fig. 3

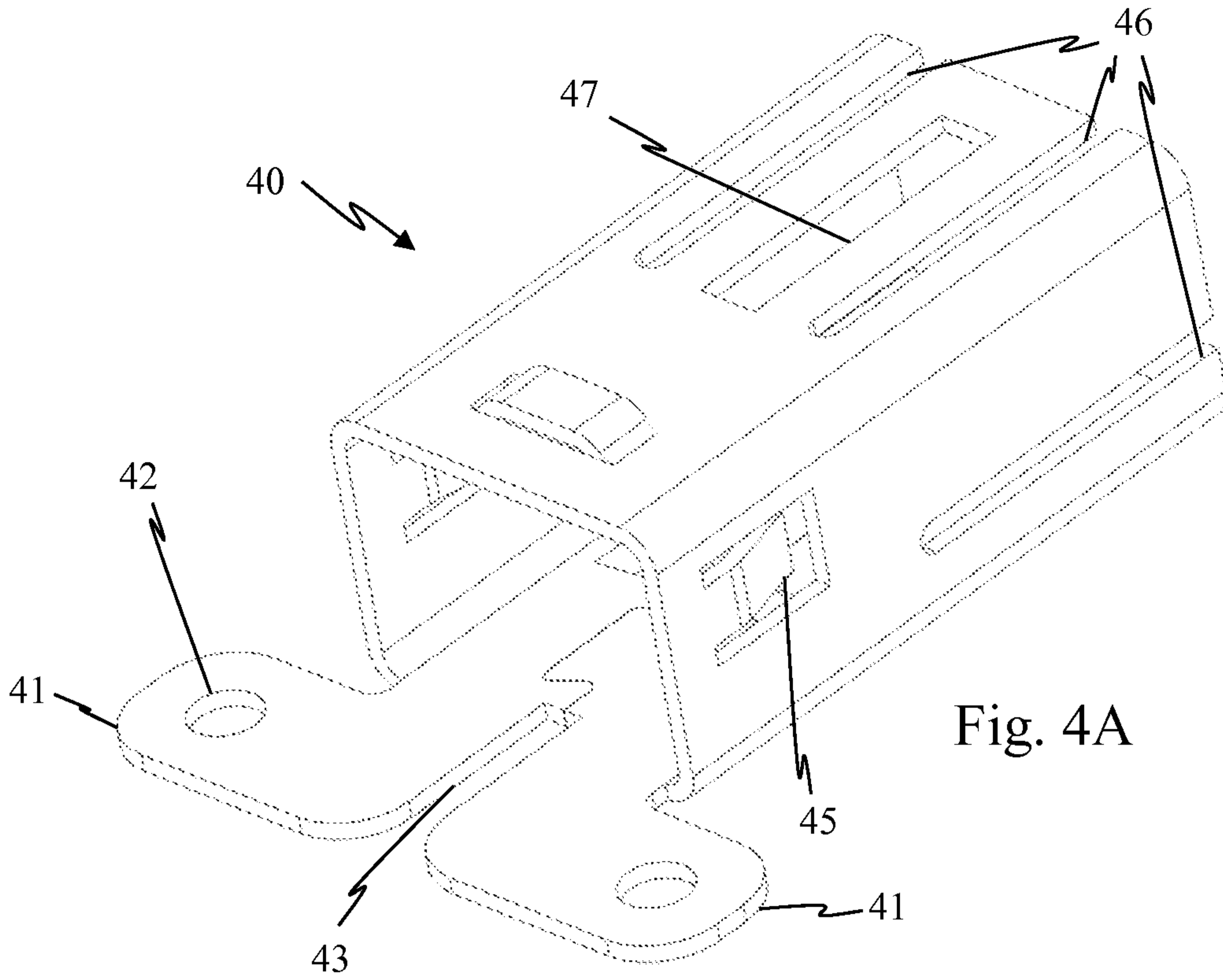

Fig. 4A

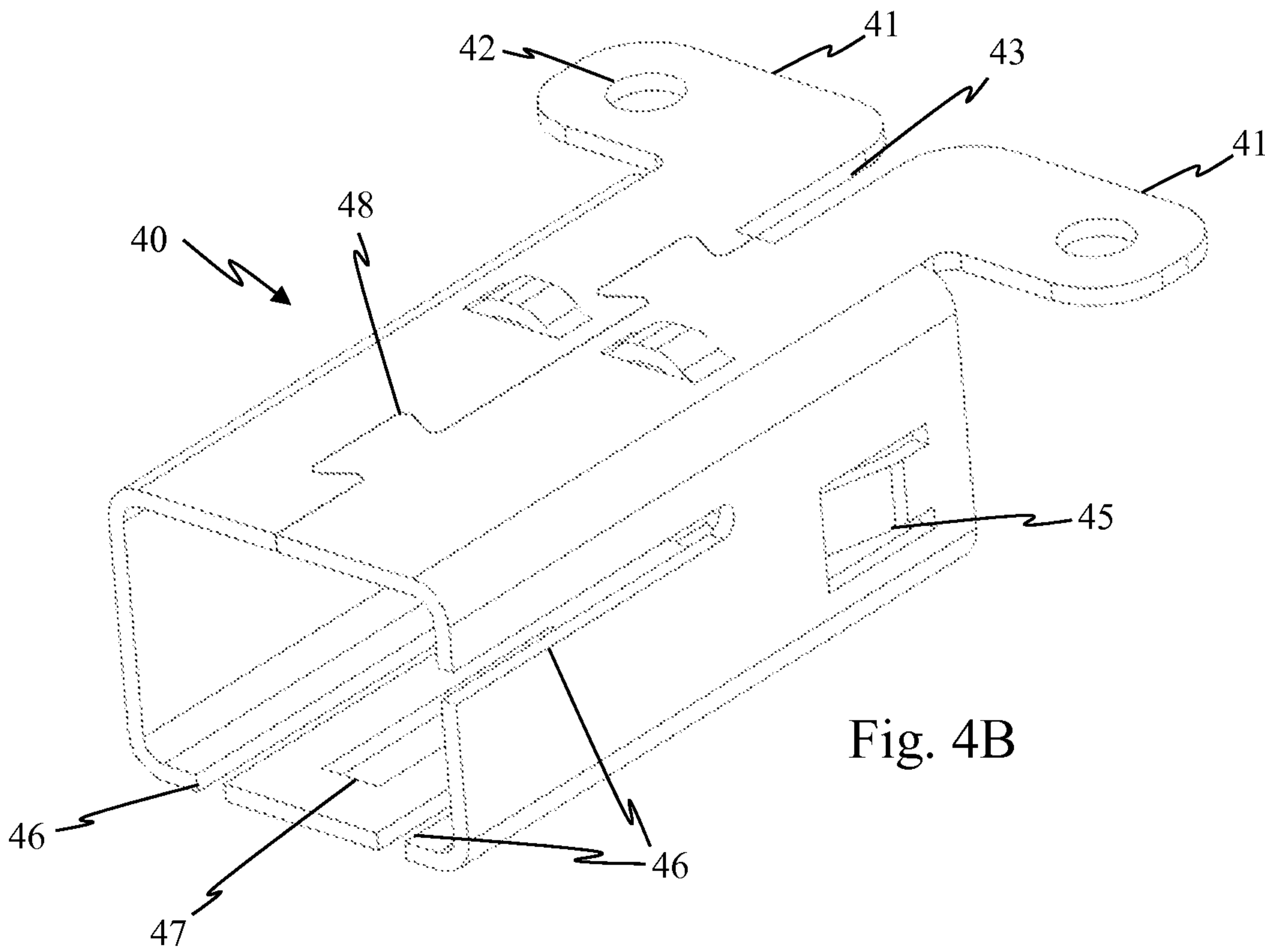

Fig. 4B

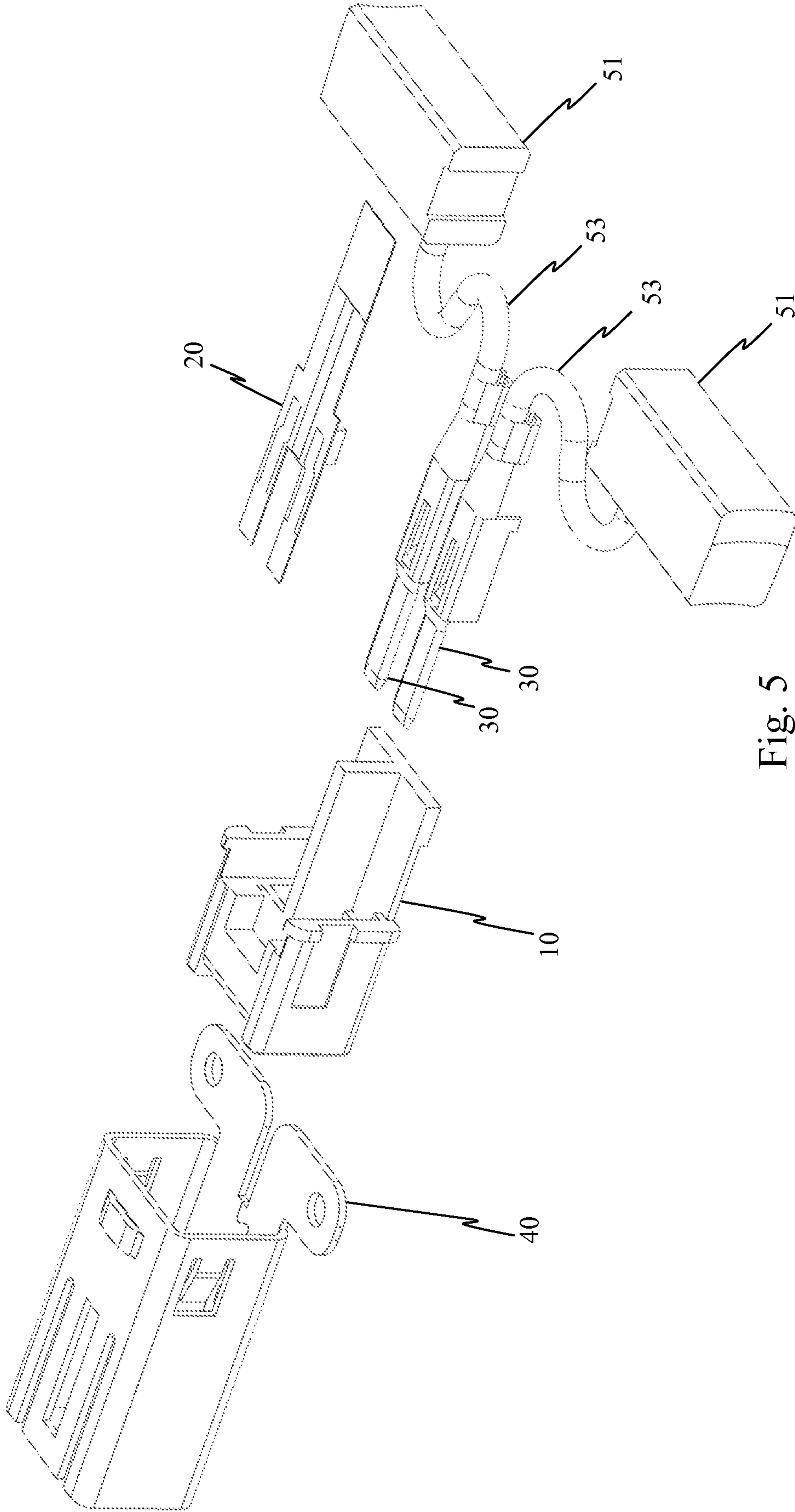

Fig. 5

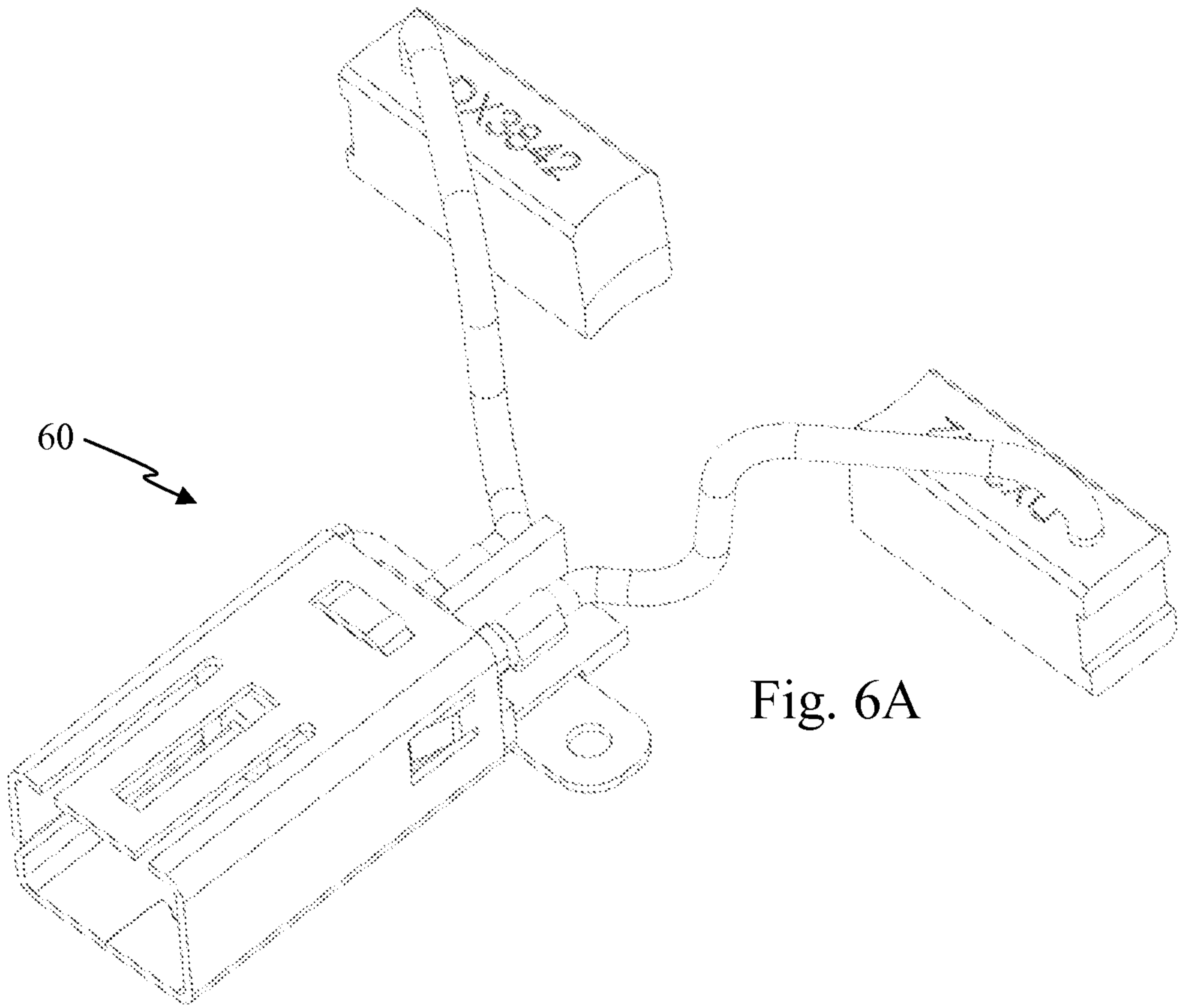

Fig. 6A

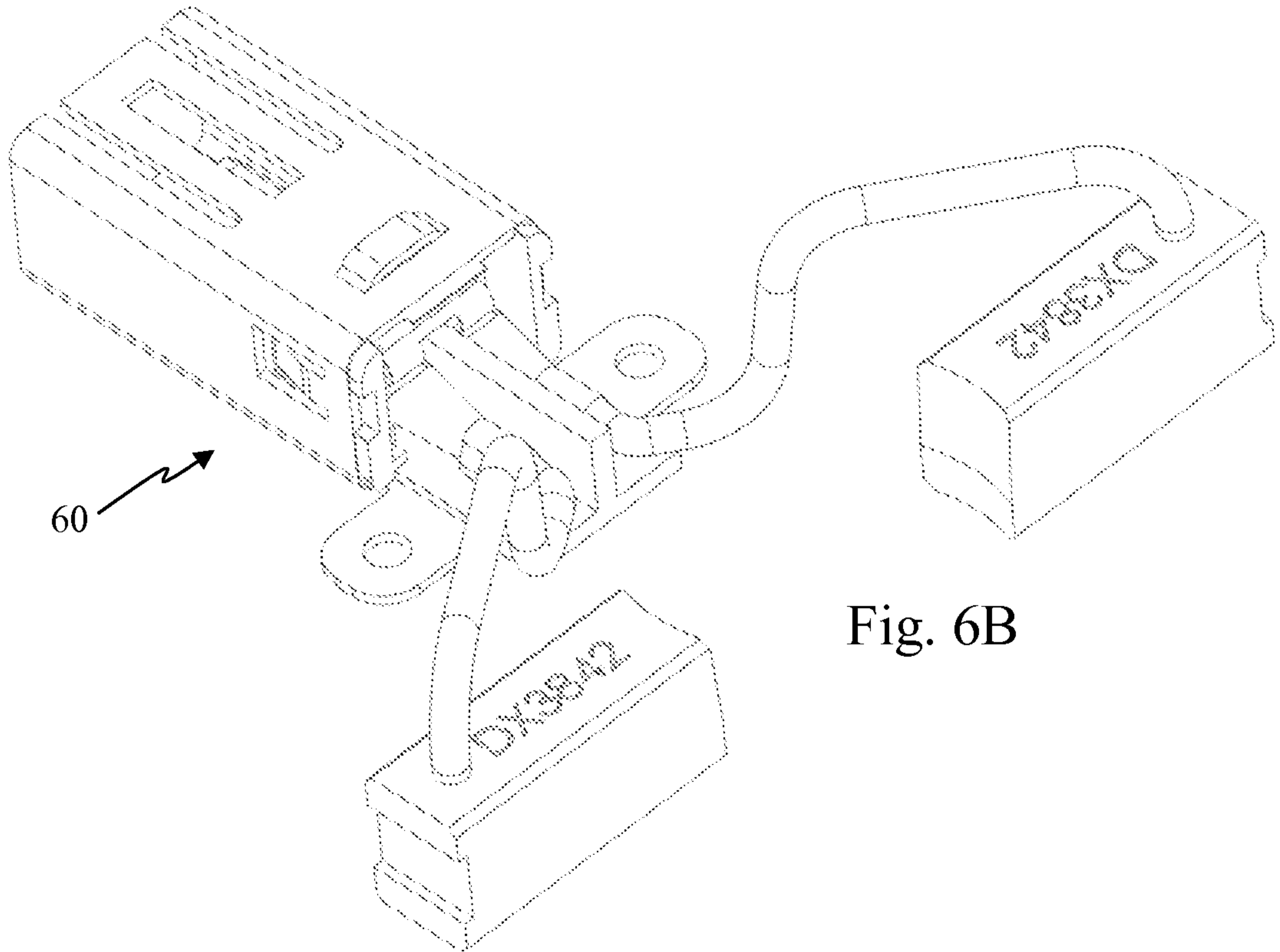

Fig. 6B

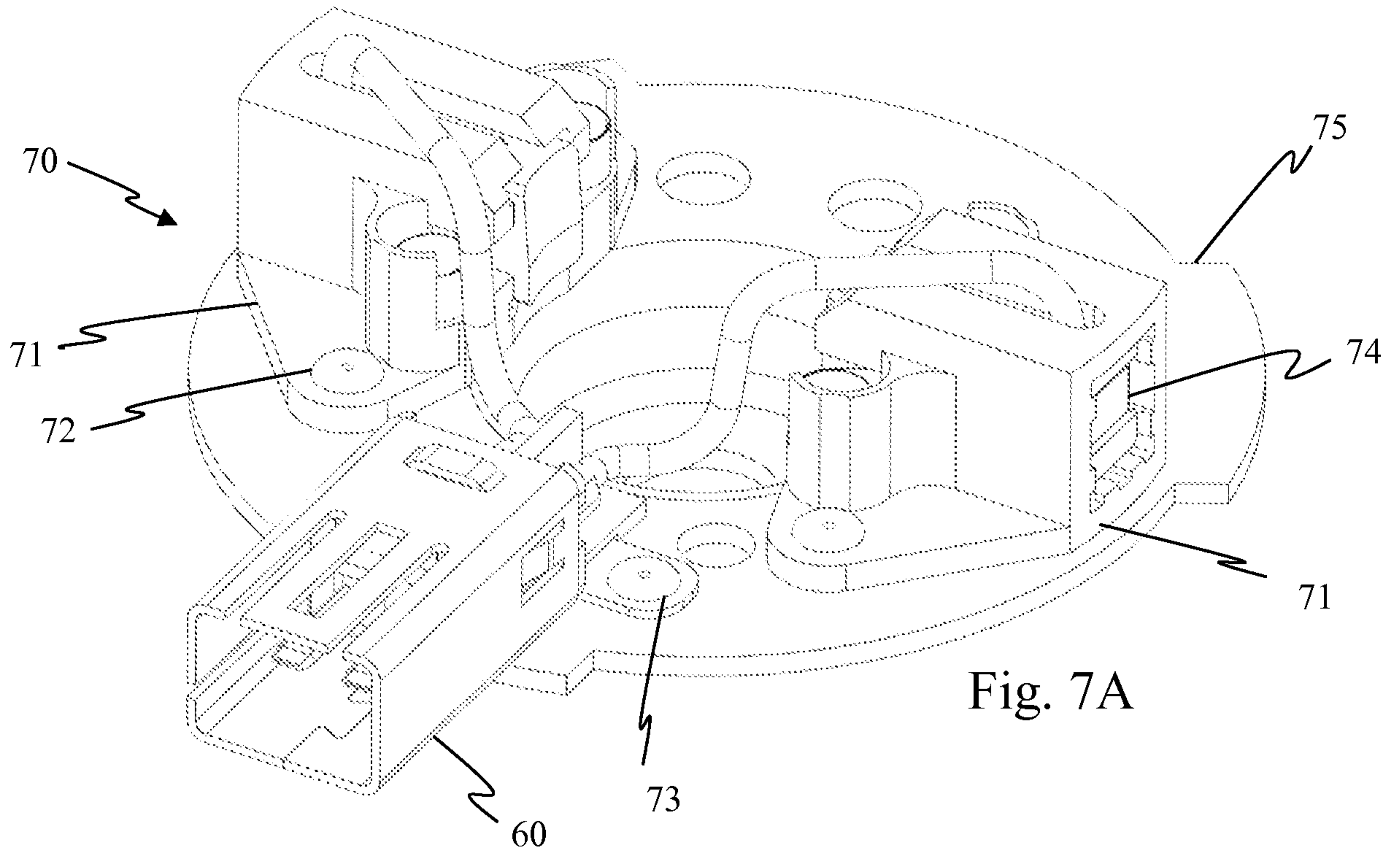

Fig. 7A

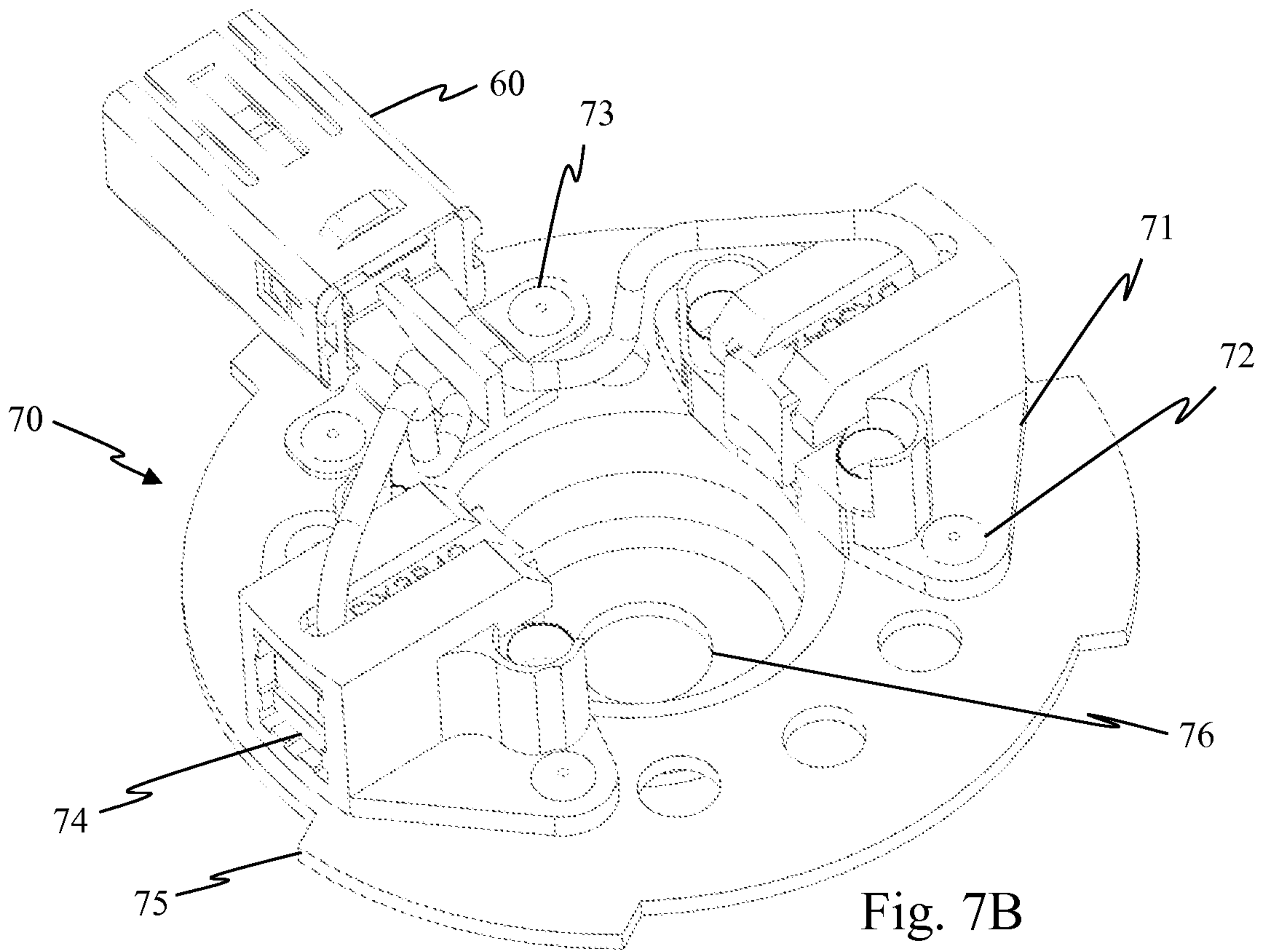

Fig. 7B

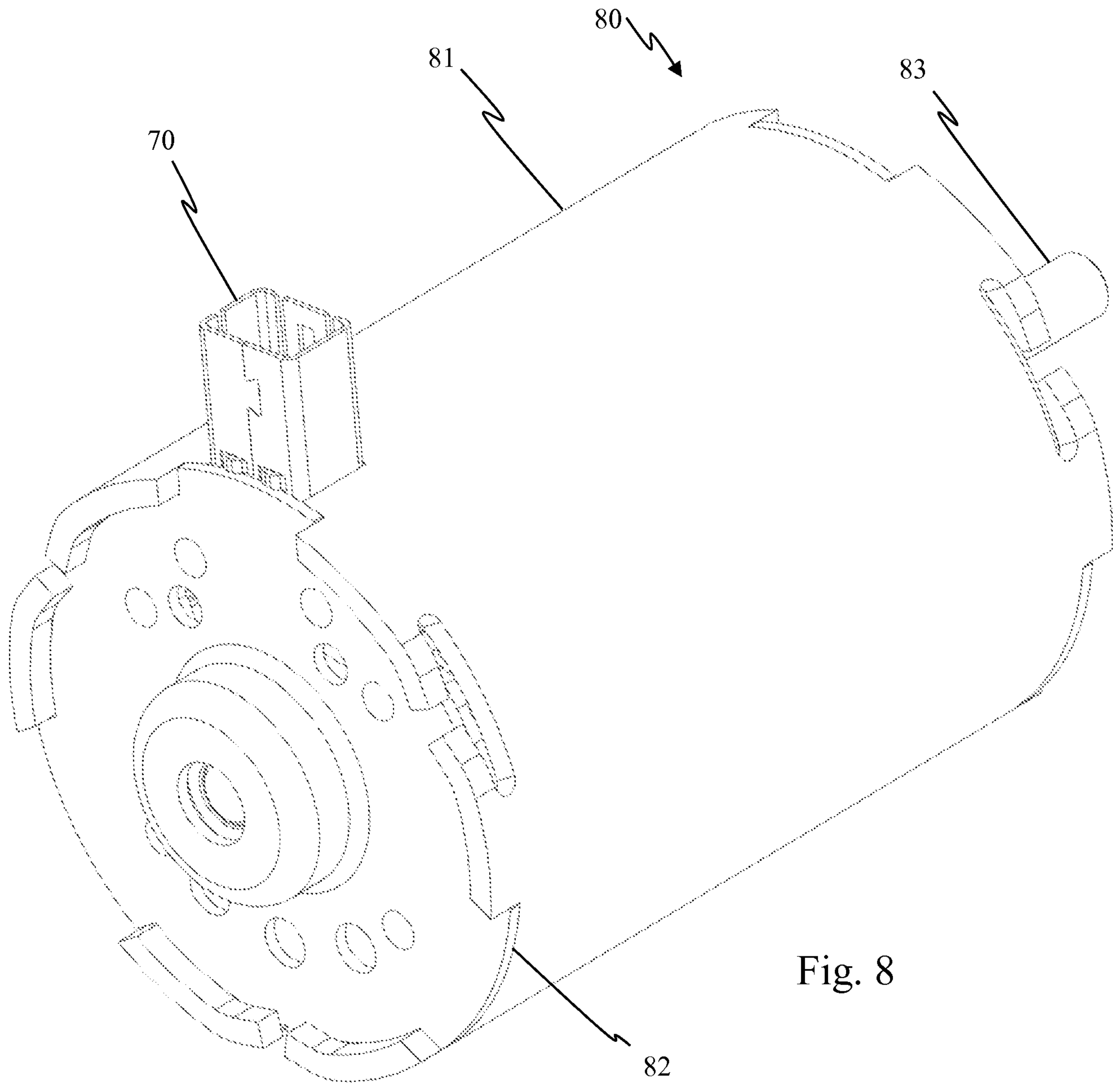

Fig. 8

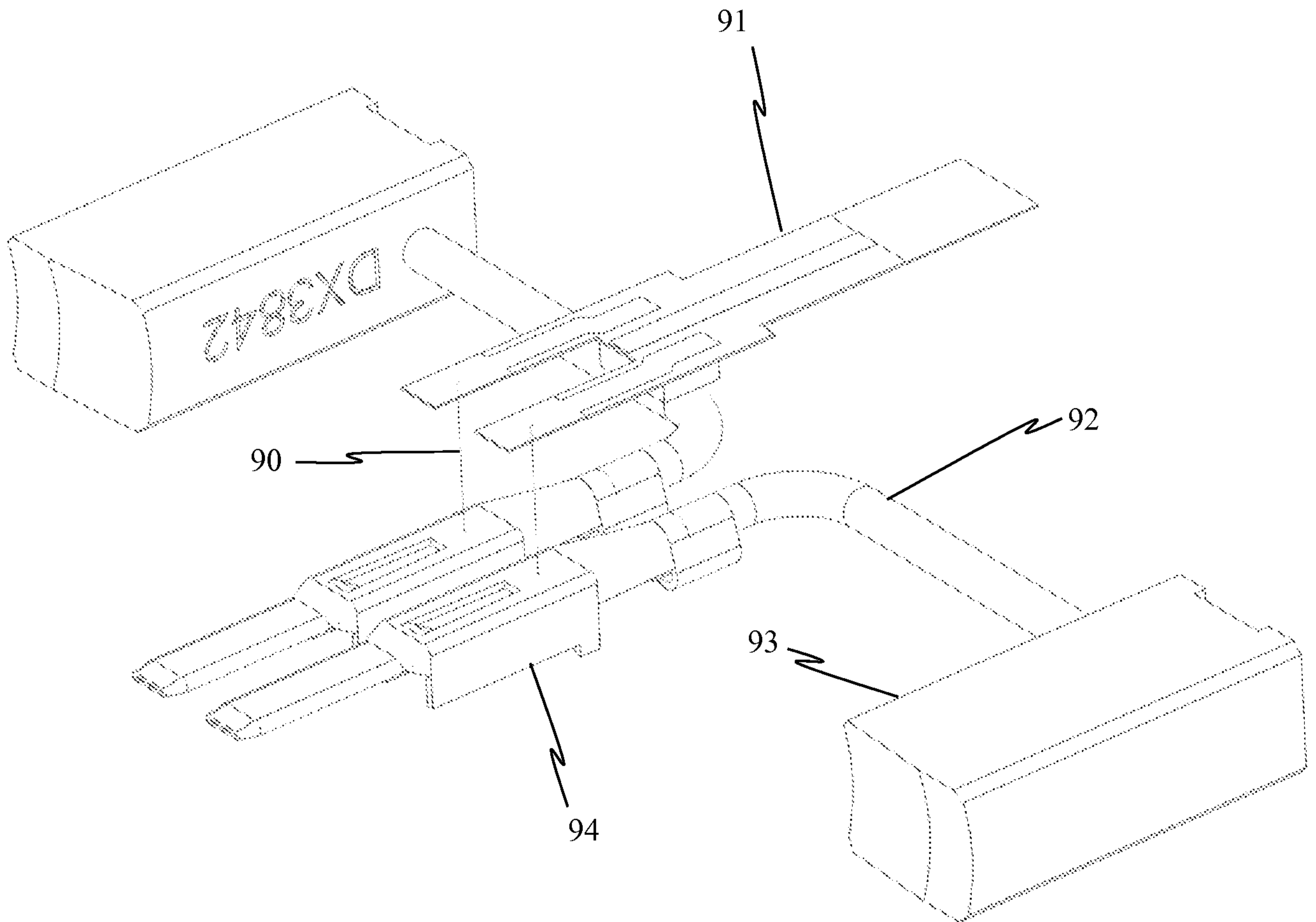

Fig. 9

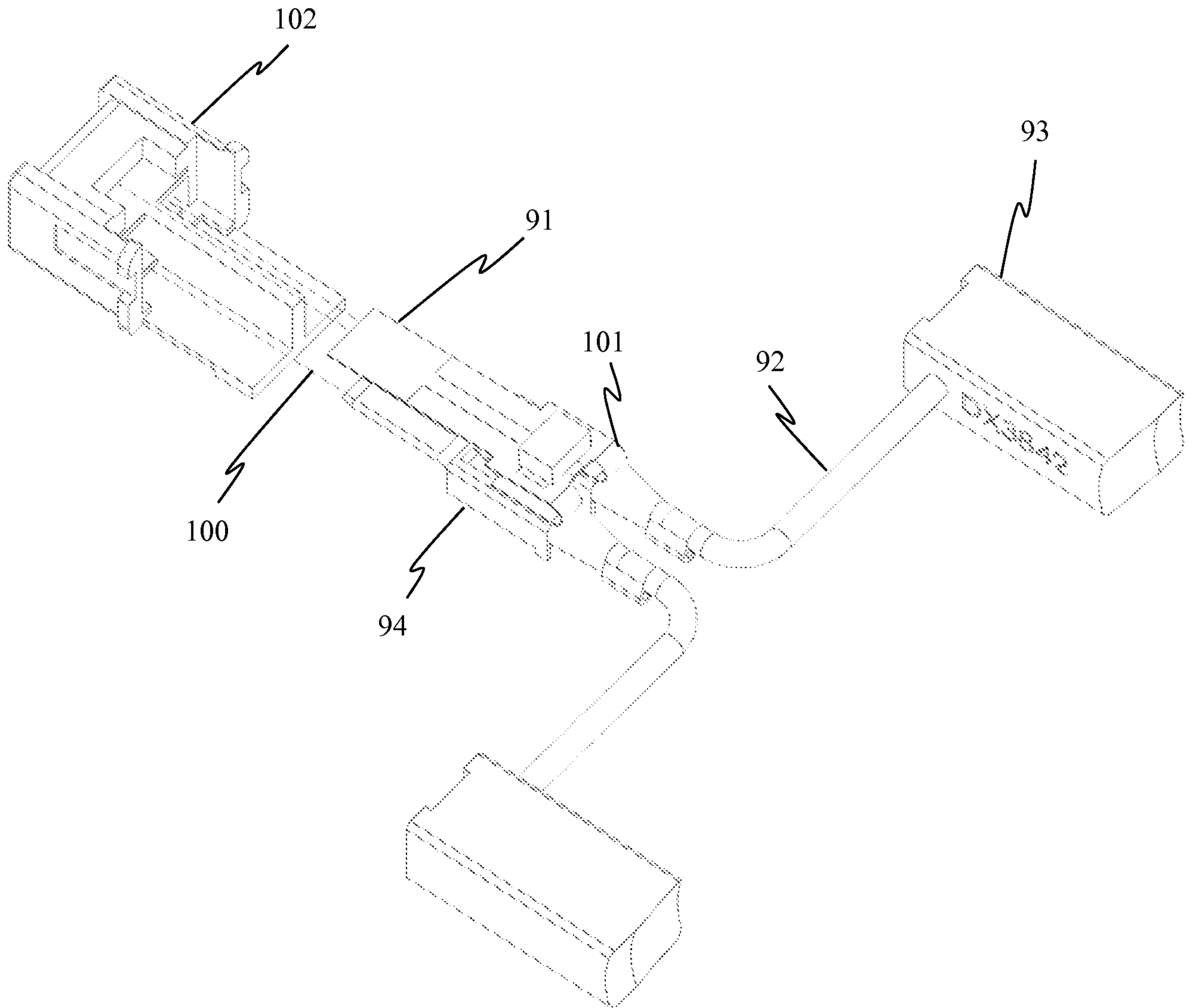

Fig. 10

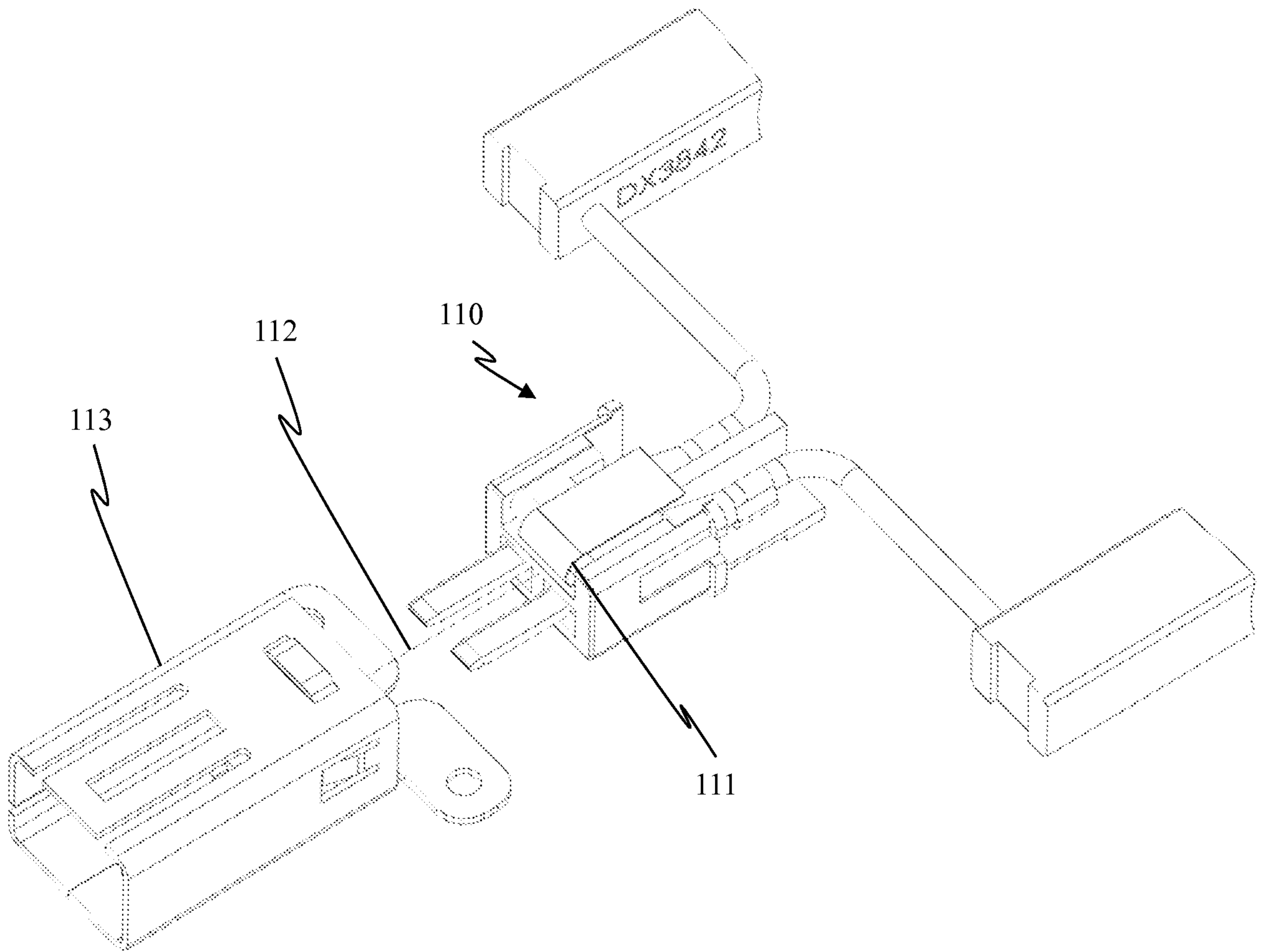

Fig. 11

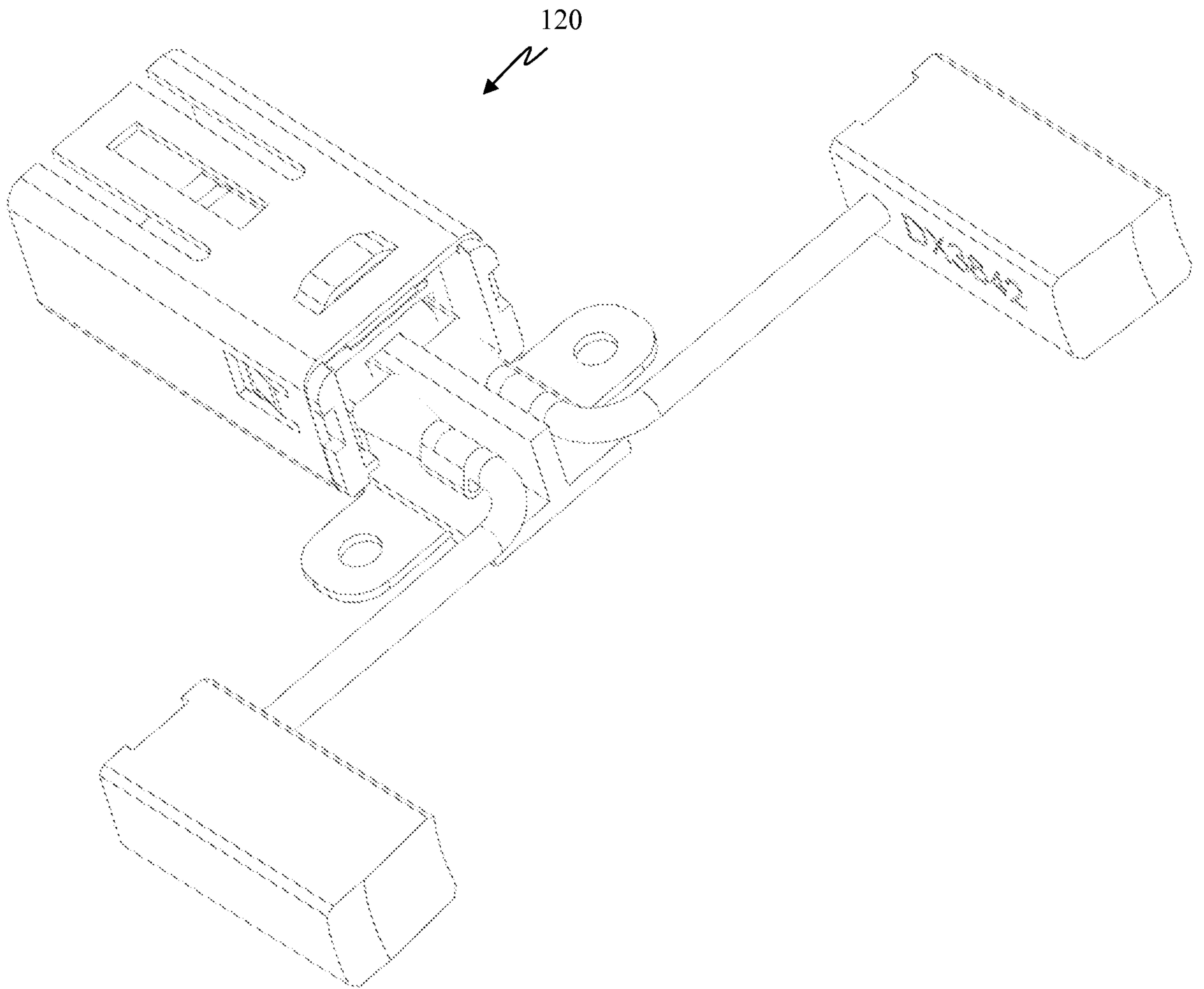

Fig. 12

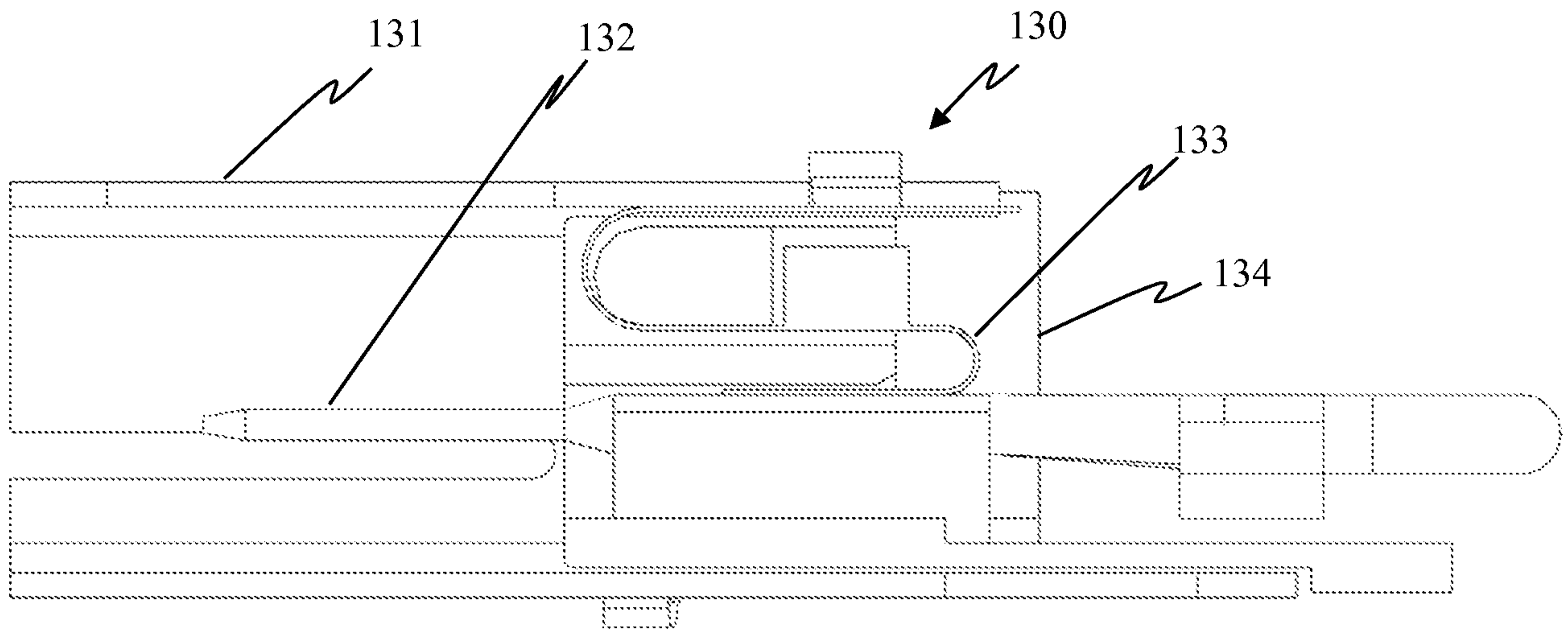

Fig. 13A

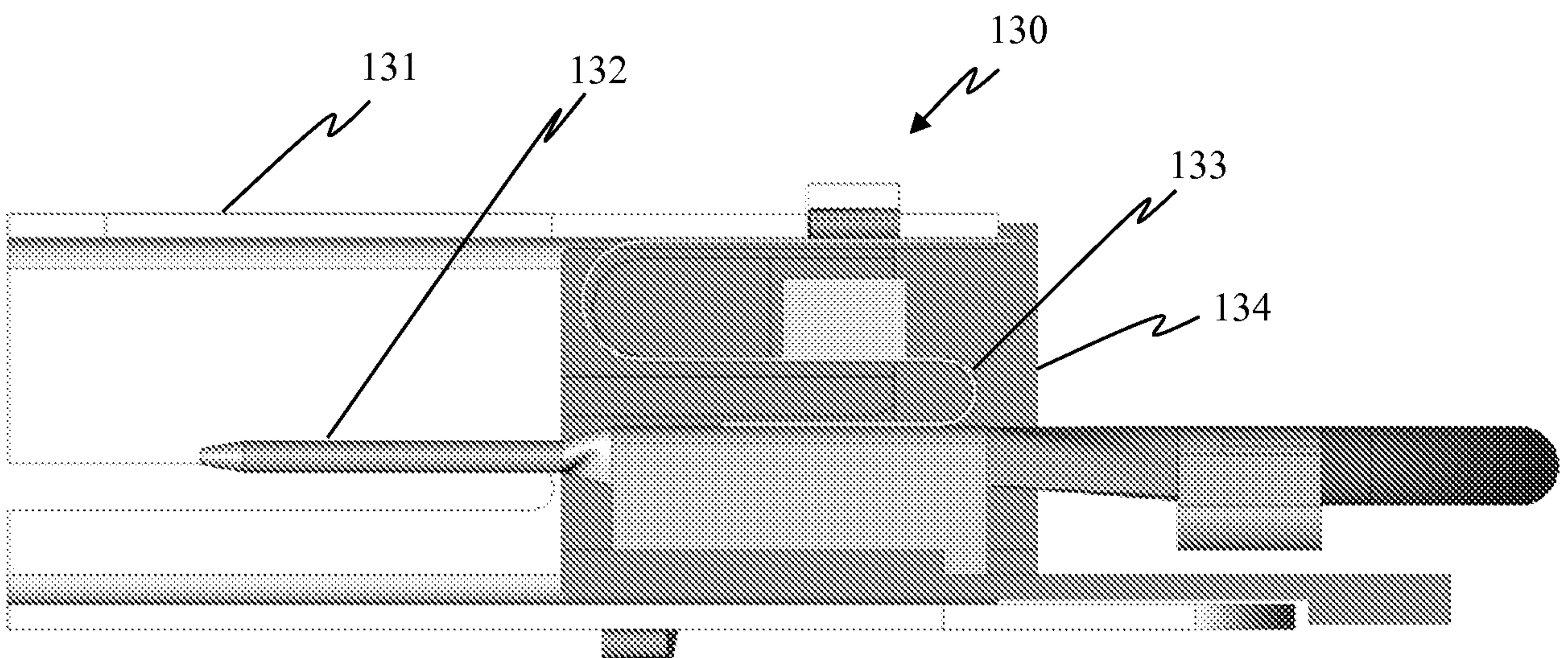

Fig. 13B

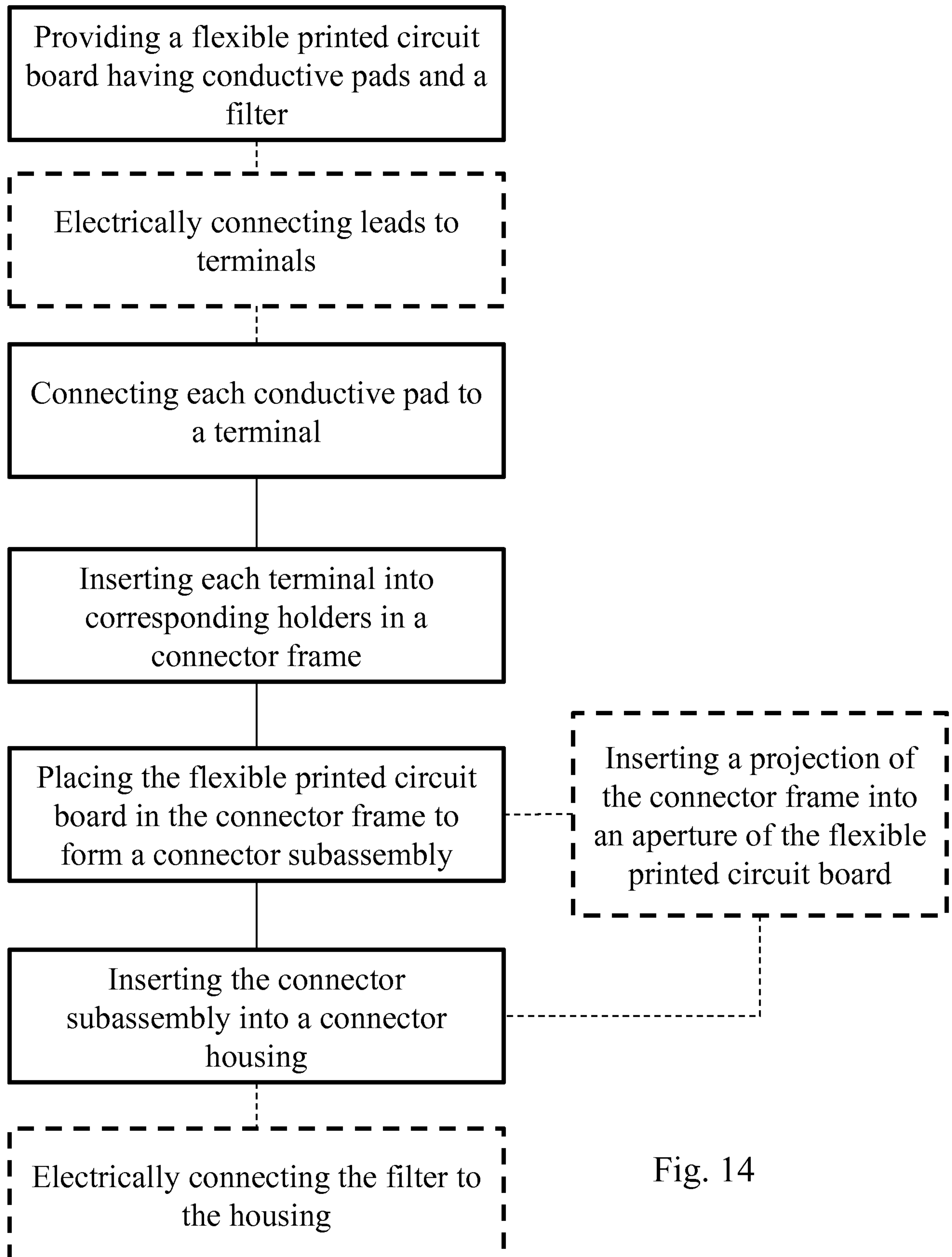

Fig. 14

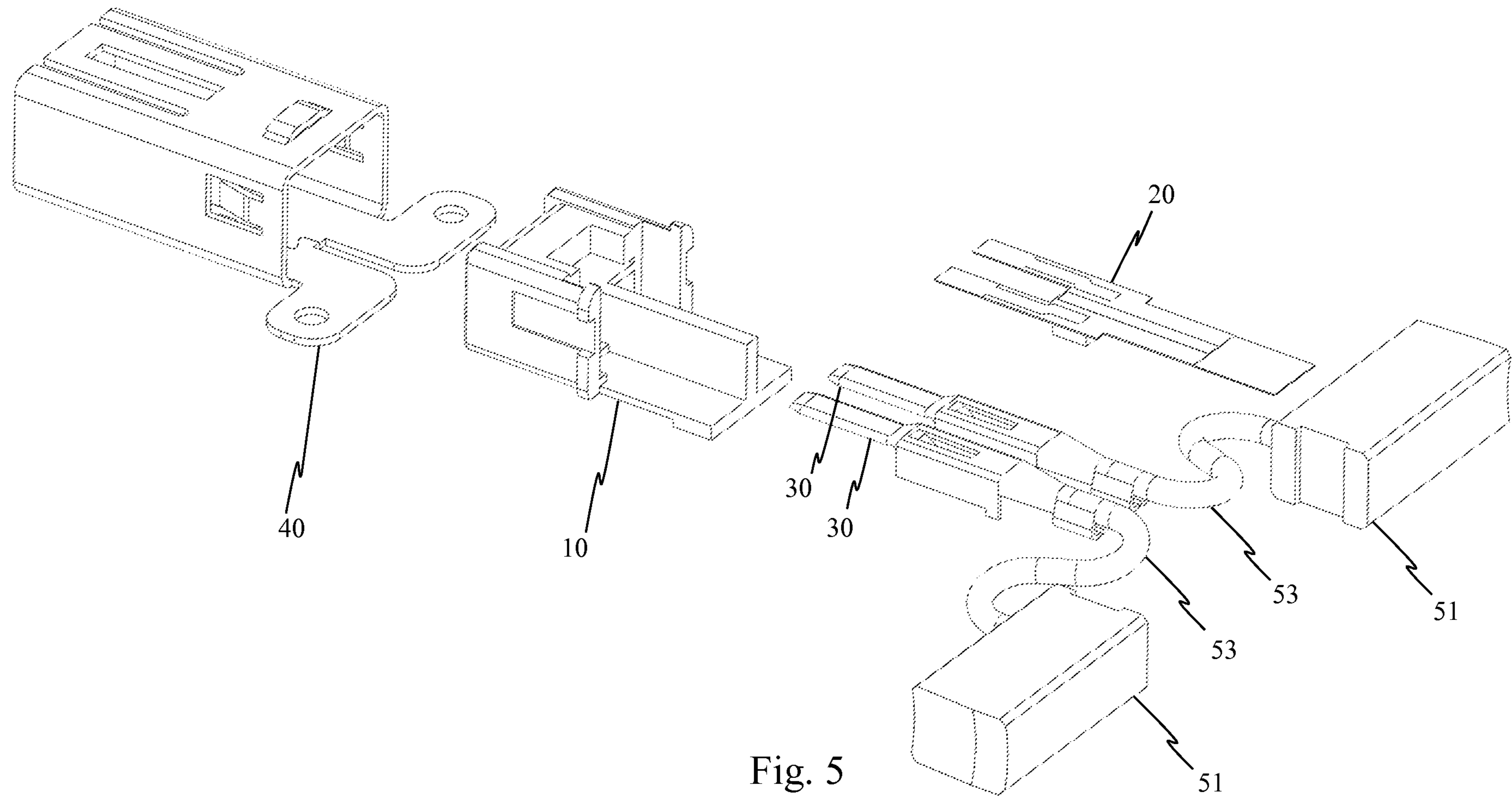

Fig. 5