

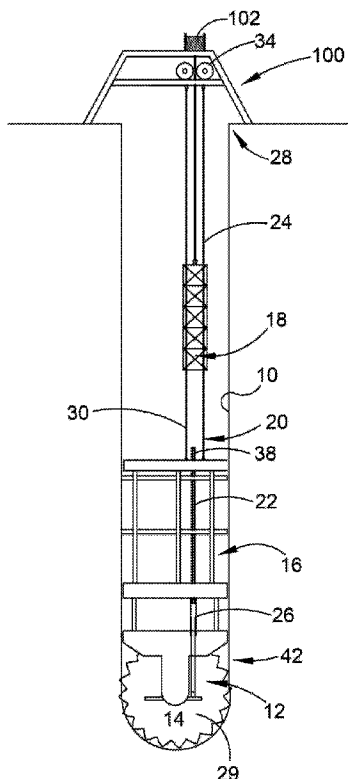

(86) Date de dépôt PCT/PCT Filing Date: 2014/08/25  
 (87) Date publication PCT/PCT Publication Date: 2015/02/26  
 (45) Date de délivrance/Issue Date: 2022/04/19  
 (85) Entrée phase nationale/National Entry: 2016/02/09  
 (86) N° demande PCT/PCT Application No.: AU 2014/000848  
 (87) N° publication PCT/PCT Publication No.: 2015/024069  
 (30) Priorité/Priority: 2013/08/23 (AU2013903212)

(51) Cl.Int./Int.Cl. *E21D 7/02* (2006.01),  
*B66B 17/00* (2006.01), *E21D 1/03* (2006.01),  
*E21D 9/12* (2006.01)  
 (72) Inventeurs/Inventors:  
WEBB, ROCKY LYNN, CA;  
DELABBIO, FREDRIC CHRISTOPHER, AU  
 (73) Propriétaire/Owner:  
TECHNOLOGICAL RESOURCES PTY. LIMITED, AU  
 (74) Agent: NORTON ROSE FULBRIGHT CANADA  
LLP/S.E.N.C.R.L., S.R.L.

(54) Titre : BENNE ET CROSSES  
 (54) Title: SKIP AND CROSSHEAD



(57) Abrégé/Abstract:

A conveyance system for moving a conveyance along a mine shaft during shaft construction, comprising: a first guide section; a second guide section located along the mineshaft in series with the first guide section, the conveyance being movable along the first guide section; and a head section for receiving the conveyance, the head section cooperating with the first guide section to enable the conveyance to travel from the second guide section along the first guide section when received by the head section.

(12) INTERNATIONAL APPLICATION PUBLISHED UNDER THE PATENT COOPERATION TREATY (PCT)

(19) World Intellectual Property Organization  
International Bureau



(10) International Publication Number  
**WO 2015/024069 A1**

(43) International Publication Date  
26 February 2015 (26.02.2015)

- (51) International Patent Classification:  

E21D 7/02 (2006.01)	E21D 1/03 (2006.01)
E21D 9/12 (2006.01)	B66B 17/00 (2006.01)
- (21) International Application Number: PCT/AU2014/000848
- (22) International Filing Date: 25 August 2014 (25.08.2014)
- (25) Filing Language: English
- (26) Publication Language: English
- (30) Priority Data: 2013903212 23 August 2013 (23.08.2013) AU
- (71) Applicant: TECHNOLOGICAL RESOURCES PTY. LIMITED [AU/AU]; 123 Albert Street, Brisbane, Queensland 4000 (AU).
- (72) Inventors: WEBB, Rocky Lynn; 1249 Lakeshore Drive, North Bay, Ontario P1B 8Z4 (CA). DELABBIO, Fredric Christopher; 69 Burton Lane, Samford, Queensland 4520 (AU).
- (74) Agent: GRIFFITH HACK; Level 19, 109 St Georges Terrace, Perth, Western Australia 6000 (AU).
- (81) Designated States (unless otherwise indicated, for every kind of national protection available): AE, AG, AL, AM, AO, AT, AU, AZ, BA, BB, BG, BH, BN, BR, BW, BY, BZ, CA, CH, CL, CN, CO, CR, CU, CZ, DE, DK, DM, DO, DZ, EC, EE, EG, ES, FI, GB, GD, GE, GH, GM, GT,

[Continued on next page]

(54) Title: SKIP AND CROSSHEAD

(57) Abstract: A conveyance system for moving a conveyance along a mine shaft during shaft construction, comprising: a first guide section; a second guide section located along the mineshaft in series with the first guide section, the conveyance being movable along the first guide section; and a head section for receiving the conveyance, the head section cooperating with the first guide section to enable the conveyance to travel from the second guide section along the first guide section when received by the head section.



WO 2015/024069 A1

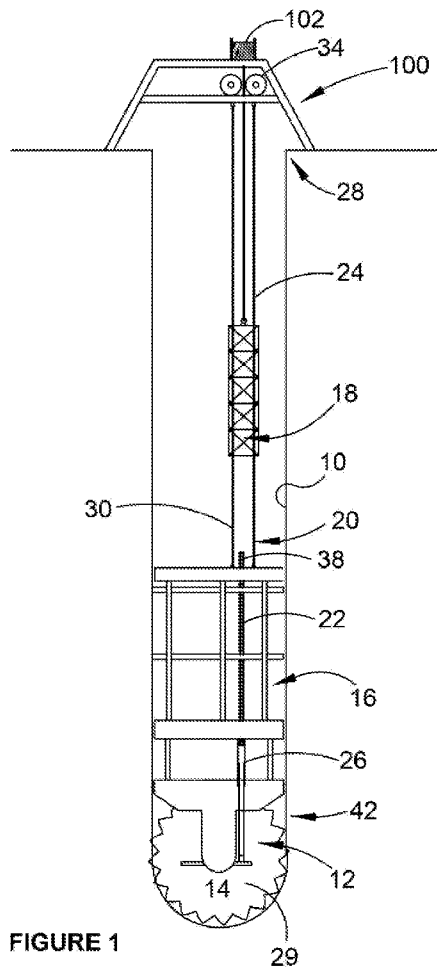

FIGURE 1

**WO 2015/024069 A1** 

HN, HR, HU, ID, IL, IN, IR, IS, JP, KE, KG, KN, KP, KR, KZ, LA, LC, LK, LR, LS, LT, LU, LY, MA, MD, ME, MG, MK, MN, MW, MX, MY, MZ, NA, NG, NI, NO, NZ, OM, PA, PE, PG, PH, PL, PT, QA, RO, RS, RU, RW, SA, SC, SD, SE, SG, SK, SL, SM, ST, SV, SY, TH, TJ, TM, TN, TR, TT, TZ, UA, UG, US, UZ, VC, VN, ZA, ZM, ZW.

TZ, UG, ZM, ZW), Eurasian (AM, AZ, BY, KG, KZ, RU, TJ, TM), European (AL, AT, BE, BG, CH, CY, CZ, DE, DK, EE, ES, FI, FR, GB, GR, HR, HU, IE, IS, IT, LT, LU, LV, MC, MK, MT, NL, NO, PL, PT, RO, RS, SE, SI, SK, SM, TR), OAPI (BF, BJ, CF, CG, CI, CM, GA, GN, GQ, GW, KM, ML, MR, NE, SN, TD, TG).

**(84) Designated States** (unless otherwise indicated, for every kind of regional protection available): ARIPO (BW, GH, GM, KE, LR, LS, MW, MZ, NA, RW, SD, SL, ST, SZ,

**Published:**

— with international search report (Art. 21(3))

SKIP AND CROSSHEAD

Priority

Priority is claimed from Australian provisional  
5 patent application No. AU 2013903212.

Field of the Invention

This invention relates to guiding movement of a  
conveyance up and down a mine shaft. It has particular  
10 but not exclusive application to guiding conveyances that  
convey materials and personnel up/down a mine shaft from  
top of shaft to an excavation region during formation of  
the mine shaft, and it may also have application to other  
purposes such as the delivery of personnel and materials  
15 up/down a mineshaft between successive lateral branches of  
the mineshaft at different underground depths.

This invention also relates to mine shaft  
conveyance systems for raising and/or lowering a  
conveyance in a mine shaft.

20

Background of the Invention

Traditional shaft sinking operations are carried  
out by drilling and blasting to excavate materials from a  
mine shaft. The excavated material is removed by a mucking  
25 system, by which the excavated material is picked up and  
deposited in kibbles (large cylindrical buckets) that are  
hoisted to the surface on cables extending downwardly from  
headgear incorporating a hoist at the top of mine shaft.

Shaft sinking and mine constructions methods using  
30 blasting and mucking processes are slow and discontinuous.  
In this context, 'discontinuous' refers to shaft  
construction taking place slowly, with each stage in the  
drill, blast and mucking cycle all being done in series  
with minimal processes being completed in parallel. For  
35 example, the time between mucking stages is lengthy since  
after completion of one mucking stage, mucking equipment  
is removed from the shaft bottom, drilling equipment is

lowered to the shaft bottom to drill boreholes, charges are then set in the bore holes, all equipment is removed from the bottom of the mine shaft, charges are initiated, and then the next mucking stage commences.

5 More recently there have been proposals to increase the speed at which sinking can progress by using mechanical excavation technology similar to that used in the horizontal civil tunnelling industry. International patent publication number WO 2011/000037A1 discloses such  
10 a proposal for sinking a mine shaft in which rock excavated by a boring machine is transferred into large capacity conveyances in the form of skips which are raised and lowered by a hoisting system installed at the top of mine shaft. On completion of shaft sinking operations the  
15 hoisting system and skips may subsequently be operated to convey material excavated during production mining stage of the mine life.

In the equipment disclosed in WO 2011/000037A1, each loaded skip or other conveyance must travel down the  
20 mine shaft and through a work stage or "Galloway". The requirements of the system that controls and/or guides movement of the respective conveyance change as the conveyance moves through different sections (e.g. moving through the Galloway versus moving from top of mine shaft  
25 to the Galloway) of a mine shaft. The present invention provides a system to meet one or more of the changes in system requirements.

The term "skip" refers inter alia to a conveyance used to bring mined material to the top of a  
30 mine shaft. Skips are manufactured in various sizes and designs for both vertical and incline shafts, and generally include bottom door dump type conveyances.

Skips are distinct from "buckets" insofar as:

- 35
- a) skips are self-dumping;
  - b) the properties of skips make them suitable for use in production shafts and

have never previous to this invention  
been used in construction/sinking of a  
shaft;

5

c) skips are, during normal operation,  
attached at all times to the hoist rope;  
and

10

d) skips do not have to be able to free  
stand on the bottom of a mine shaft (i.e.  
can be extremely long and slender).

A "bucket" and "kibble" are typically  
cylindrical shaped conveyances, use to transport  
blasted rock from the shaft bottom, during shaft  
construction (sinking) operations.

15

When compared with skips, buckets:

20

a) require manual dumping  
b) must be unloaded in a tip over fashion  
c) are attached to the hoist rope via  
detachable hook to suspension chains (or  
bales) at the top of the bucket (minimum  
of 3 to maintain stability)

25

d) must be used in conjunction with a  
crosshead to provide guidance in the  
shaft barrel (above work stage)

30

e) are unguided (both in terms of rotation  
and swing) below shaft guide system or  
within work stage, and also below work  
stage

35

f) are regularly disconnected from the hoist  
rope (generally to load at shaft bottom)  
during the loading operation

g) must be round and have a height to  
diameter ratio that is stable and will  
stand unsupported on shaft bottom

5 h) must have a smooth outer surface so as to allow the bucket to work with bump guides to prevent swaying, and accordingly cannot have guide couplings attached to their outer surface.

10 Unless context specifies otherwise, the term "guide" as used herein refers to a member along which a conveyance travels down a mine shaft, and that resists or prevents both rotation of the conveyance and lateral movements of the conveyance relative to the mine shaft. Such a "guide" provides no motive or drive force to cause movement of the conveyance.

15 Summary of the Invention

The present invention provides a conveyance system for moving a conveyance along a mine shaft during shaft construction, comprising:

- 20 a first guide section;
- a second guide section located along the mine shaft in series with the first guide section, the conveyance being movable along the first guide section; and
- 25 a head section for receiving the conveyance, the head section cooperating with the first guide section to enable the conveyance to travel from the second guide section along the first guide section when received by the head section.

30 The head section may include a containing section in which the conveyance is at least partially received during travel of the conveyance along the first guide section.

The head section may include a chairing member that chairs against the conveyance during travel of the conveyance along the first guide section.

35 The chairing member may come into abutment with the conveyance.

The head section may be configured to depend from the conveyance during movement of the conveyance and head

section along the first guide section.

The head section may be configured to permit passage of a hoist rope attached to the conveyance by which the conveyance is lifted and/or lowered along the mineshaft.

5 The head section may be arranged so that the hoist rope can extend through the head section to the conveyance.

The conveyance system may be arranged such that the head section chairs against a work stage as the conveyance travels from the first guide section along the second guide section.

The conveyance system may be arranged such that the head section does not travel along the second guide section.

15 The mine shaft may be substantially vertical.

The first guide section may be a variable length guide section and the second guide section may be a fixed length guide section.

The first guide section and second guide section may restrict rotational movement and swing movement of the conveyance.

The first guide section and second guide section may substantially prevent rotational movement and swing movement of the conveyance.

25 The conveyance system may concurrently guide multiple conveyances.

The first and second guide sections may guide each of the multiple conveyances.

30 Personnel and/or materials may be transported in a different one or ones of the conveyances to one or more conveyances that transport mined material.

The present invention further provides a guide system for guiding a conveyance during shaft construction, while lifting and/or lowering of the conveyance in a mine shaft, the system comprising:

an intermediate fixed length guide section; and  
a variable length upper guide section extending from

the intermediate section to accommodate changes in distance between the intermediate section and an upper region of the mineshaft, wherein the guide system restricts rotational movement and swing movement of the conveyance.

The guides may be configured to allow the conveyance to transition from one guide section to the other

The guide system may further include a variable length lower guide section extending from the intermediate section to accommodate changes in distance between the intermediate section and a lower region of a mineshaft.

The lower guide section may be extendable without a corresponding extension and/or retraction of the upper guide section.

The lower guide section may retract as the upper guide section extends. The upper guide section may in fact be extendable with downward movements of the intermediate section. The lower guide section may extend between the intermediate section and a shaft forming apparatus and extend with movements of the shaft forming apparatus away from the intermediate section, and retract with movement of the intermediate section towards the shaft forming apparatus.

In some embodiments, the upper guide section extends from top of shaft down to a work stage where the upper guide section meets the intermediate section. The intermediate section is fixed to the work stage and extends through the work stage to the variable length guide system. The lower guide section may extend from the work stage to a shaft forming apparatus, extending as the shaft is formed and retracting as the work stage (and therewith the intermediate section) advances down the mine shaft towards the shaft forming apparatus.

The upper guide section and intermediate section may meet at a transition region, and the conveyance may comprise a head section and a base section, the transition region being adapted to halt downward travel of the head

section whilst permitting the base section to continue downward travel along the intermediate section.

The invention may be designed for use in a substantially vertical mineshaft.

5           The invention also extends to a mine shaft conveyance system comprising a guide system as set out above, and a hoist system for lifting and/or lowering the conveyance along the guide system.

10           Embodiments of the present system may achieve higher mine shaft sinking speeds along with safer operation of conveyances along the length of the mine shaft.

#### Brief Description of the Drawings

15           In order that the invention may be more fully explained one particular embodiment will be described in detail with reference to the accompanying drawings in which:

20           Figure 1 is a side schematic view of a mine shaft-boring machine employing a guide system according to an embodiment of the present invention;

25           Figure 2 is a side perspective view of a conveyance, including head and base sections, in engagement with the upper guide section (stage ropes) of the guide system;

30           Figure 3 is a side perspective view of a base section of the conveyance of Figure 2 engaged with an intermediate or workstage section (fixed guides) of the guide system;

35           Figure 4 is a side perspective view of a head section of the conveyance of Figure 2 engaged with the upper guide section (stage ropes) of the guide system;

            Figure 5 is a side schematic view of a lower guide section (telescopic guides);

            Figures 6 and 7 show side views of a crosshead or 'bridle';

            Figures 8 and 9 show side views of a skip;

Figures 10 and 11 show side views of a crosshead or  
bridle, with a skip received therein; and

Figure 12 is a side perspective view of a crosshead  
or bridle;

5 Figure 13 is a side perspective view of an  
auxiliary cage or conveyance including a personnel  
carrier; and

Figure 14 is a side perspective view of the  
crosshead of Figure 12 when received over the conveyance  
10 of Figure 13.

Detailed Description of the preferred Embodiment

• TRADITIONAL SHAFT SINKING

15

Traditionally, shaft sinking processes have used  
blasting and mucking methods to deepen a mine shaft.  
Material at the bottom of a mine shaft is drilled,  
explosive charges are set, the bottom of the mine shaft is  
20 blasted, and blasted rock is loaded into a conveyance for  
transport to top of shaft. Finally, people and material  
are moved from the top of shaft down the shaft to the  
shaft bottom and to working locations such as the work  
stage.

25

• BUCKETS - KIBBLES

In traditional shaft sinking, kibbles (large  
buckets) have been used for transporting people and rock.  
30 This type of conveyance has been used for 100's of years.

There are many reasons why kibbles have been  
traditionally used during shaft sinking. In order to  
enable ready loading of a conveyance (e.g. a kibble) at  
35 the bottom of a mineshaft, the conveyance should be:

- 'open topped' to enable material to be dropped into  
it by a loader;

- 'freely moveable' to enable the conveyance to be located at a desirable position on the bottom of the mineshaft. The bottom of the mineshaft is typically highly irregular due to it constituting blasted rock. So a freely moveable conveyance can be stably positioned at an appropriate location for filling by the loader;
- 'cylindrical' so that the open top of the conveyance is accessible in a similar manner regardless of where the conveyance is located relative to the loader during loading of the conveyance; and
- 'connected at its top to a hoist rope' - the only logical way to lift a freely moving, cylindrical conveyance.

Clearly, buckets and kibles (large buckets) provide these characteristics and are thus the main form of conveyance used in mine shaft sinking/construction processes.

• DRAWBACKS OF BUCKETS AND KIBBLES

Buckets and kibles are freely suspended and unable to have attached, to an outer surface thereof, mechanisms for allowing the bucket or kibble to be coupled to a guide. One reason for this is as provided above in point (h) of the Background of the Invention. Once the cross head reaches the Galloway (workstage) the bucket hangs freely, is only constrained horizontally within the workstage but is able to rotate. Once the bucket is below the workstage it is not possible to constrain horizontal swing or rotation. As a result of the above, hoist speeds of the conveyance are reduced within the workstage and below the workstage.

In addition the lack of full guidance of the conveyance, and the general inability to fully guide the conveyance,

causes health and safety risks when transporting people. This is because absolute alignment of the conveyance with, for example, a high tolerance, engineered landing pad is not possible. This creates pinch points and large  
5 hazardous gaps that must be spanned when loading and unloading people.

Also, significant time is required to align the bucket or kibble with discharge ramps and the like, and to safely  
10 tip the bucket or kibble over to discharge mined material.

Buckets and kibbles thus slow down the process of mine shaft sinking and are the root cause for some health and safety risks associated with moving people and material within the shaft.

15

As part of an initiative to double the speed of shaft construction and to improve the health and safety of shaft sinking miners, a new shaft sinking system has been  
20 developed. This system replaces drilling and blasting of the rock with disc cutters to fracture the rock. This system also employs a material handling system that replaces buckets with skips for the transportation of rock, and a cage to transport people and materials.

25 A mechanical excavation system using the disc cutters to fracture the rock is embodied by mine shaft-boring, or shaft-sinking, machine 12 located in a mine shaft 10 in Figure 1. The machine 12 comprises a shaft forming apparatus, namely cutting head 14, for excavating  
30 the mine shaft 10, and a work stage 16 on which personnel install concrete lining and shaft services in parallel with the excavation of the shaft. Such a mine shaft-boring machine is described in WO2011/000037 in which a rotary cutting head is mounted to a lower end of a main machine  
35 frame and is equipped with disc cutters for excavating the rock. Cuttings from the cutting head are passed upwardly to a discharge/loading station in the work stage and are

transferred to skips for ascending the shaft to the top of shaft.

• CHALLENGES TO OVERCOME IN USING SKIPS DURING  
5 CONSTRUCTION

Based on skips used in production mining, it has been realised by the inventors that if skips could somehow be used in shaft sinking to convey and discharge material  
10 the rate of shaft sinking would be much greater than is the case with buckets. Also if a separate cage, able to move within the shaft independently from the skips, could be used to transport people and material instead of a bucket it would be safer and more efficient. Both of  
15 these opportunities needed the same challenges to be overcome including the provision of full conveyance guidance at all times across multiple guide systems, where the guide systems combine both fixed and flexible length systems.

20 In the embodiment shown in Figure 1, the cutter head 14 and workstage 16 will also descend at different times. So the height of the workstage 16 relative to the bottom of the mineshaft 10 will vary. Moreover, for safety reason the guides along which a skip would travel through  
25 the workstage are ideally fixed.

For these reasons, more than one type of guide system is necessary - in other words, a variable length guide extending from the top of the mineshaft to the workstage, and a fixed guide extending through the  
30 workstage.

In the embodiment shown in Figure 1, a further variable length guide system is required to span the gap between the bottom of workstage and the cutter head or shaft bottom.

35 The drawback with such systems is that skips do not readily transition between different types of guide.

While skips may be used during the production phase

of a mine where a single type of guide can be used, skips have traditionally not been workable during the construction phase of a mine. One reason for this is that skips require full guidance at all times. Skips therefore  
5 do not lend themselves to applications where multiple guide systems are present.

The inventors realise that these drawbacks are significant contributing factors to the long held understanding that skips are inappropriate for use during  
10 the construction phase.

- THE PRESENT SYSTEM

To guide movement of a conveyance, presently  
15 embodied by skip 18, the mine shaft 10 is equipped with a mine shaft conveyance system 100 comprising a guide system 20 as discussed below and a hoist system 102 for lifting and/or lowering the skip 18 along the guide system 20.

The hoist system 102 is attached to the top of the  
20 skip 18 in a known manner and applies the force necessary to controllably lift and lower the skip 18 in the mine shaft 10.

The guide system 20 guides movement of the skip 18 to ensure, for example, that it does not freely rotate  
25 during ascent/descent of the mineshaft 10. The skips 18 travels or runs along the guide system 20 for guided travel (i.e. lifting and/or lowering) of the skip 18 in the mineshaft 10.

As shown in Figure 1, the guide system 20 extends  
30 along the length of the mine shaft 10 down to the cutter head 14.

The guide system 20 can be divided into 3 sections:

1. a first or "upper" guide section 24  
35
2. a second, "lower" or "workstage" guide section 22, and

3. a third or "excavation region" guide section  
26.

5           The guide sections 24, 22, 26 extend in series from  
an upper region 28 of the mine shaft 10 to an excavation  
region 29 in which material is excavated from the mine  
shaft 10 to deepen the mine shaft 10.

10           To speed up the construction phase of a mine it is  
desirable not to have to provide and extend (i.e. during  
lengthening of the mineshaft) separate systems for the  
conveyance of mined material and the conveyance of  
personnel and/or equipment. It is therefore useful if  
15           personnel and materials are transported to the work stage  
using the same system as that used for the conveyance of  
mined material.

○ UPPER GUIDE SECTION 24

20           The upper guide section 24 extends from the  
workstage guide section 22 to accommodate changes in  
distance between the workstage guide section 22 and an  
upper region 28 of the mine shaft 10. Thus, the skip 18  
can travel along the upper guide section 24 as shown in  
25           Figure 1, between the top of shaft (e.g. an above ground  
loading/discharge region) and the work stage 16. It will  
be understood that for winze applications the upper region  
28 will not be ground level, but will be below ground  
level.

30           As the mine shaft 10 extends the distance from the  
upper region 28 to the work stage 16 increases. As a  
result, the distance from the upper region 28 to the  
workstage guide section 22 similarly increases.

35           The upper guide section 24 consequently has  
variable length to accommodate such changes in distance  
between the upper region 28 and workstage guide section  
22. It may similarly be desirable to lift the work stage

16 and so the upper guide section 24 may be retractable in addition, or as an alternative, to being extendable.

The upper guide section 24 comprises a pair of stage ropes 30 that extend up the barrel of the mine shaft 10, as shown in Figure 2. It will be appreciated that any number of ropes or alternative guide means may be used as desired, and that the ropes may be fabricated from any appropriate material (typically steel). For example, the upper guide section 24 may constitute wire ropes or cables, wound steel pipe or coiled tube, steel straps, chains and so forth. Any other elongated material or structure that can be wound in and wound out may be used as the upper guide section 24.

In a preferred embodiment, the upper guide section 24 comprises multiple pairs of stage ropes 30 enabling multiple conveyances to be guided concurrently up and down the shaft. In one such embodiment, the upper guide section 24 comprises 3 or 4 pairs of stage ropes 30, allowing for 3 to 4 conveyances to be guided simultaneously up and down the shaft.

With further reference to Figure 1, the stage ropes 30 are received on sheaves or cable drums 34 that unwind and wind to extend and retract the stage ropes 30. Thus, the upper guide section 24 is extendable and retractable. The sheaves 34 are mounted in a head frame 36 extending over the open upper end of the mineshaft 10. The ropes 30 therefore extend directly downwardly from the sheaves 34 down the mineshaft 10.

The sheaves 34 maintain sufficient tension in the stage ropes 30 to ensure that the conveyance 18 can travel up/down the upper guide section 24 without significant rotation or lateral deflection. In other words, the stage ropes 30 assist in maintaining the orientation and position of the conveyance 18 as it ascends/descends the mineshaft 10. In some embodiments, despite being extendable and retractable, the stage ropes 30 will in practice be under sufficient tension from suspending the

workstage 16 and/or other equipment, that they will form substantially rigid members with respect to any force applied by the skip 18 to the stage ropes 30.

5 The opposite ends of the stage ropes 30 are connected to the top of the work stage 16 by any appropriate cable stays or other means (e.g. eyelets, swivels). The stage ropes 30 may alternatively wind through sheaves mounted to the work stage 16. In alternative arrangements, the first (upper) guide section 10 24 may extend into the work stage 16 such that the work stage 16 is suspended from a lower point, or even from the bottom of the work stage 16. All such variations are intended to constitute part of the present disclosure.

15 In addition, the stage ropes 30 may be connected directly to the workstage guide section 22. However, the present stage ropes 30 are connected to the work stage 16 and the workstage section 22 extends along a parallel, but not collinear, path as shown in Figure 1. This is due to different guide means, namely bushings 32 and channels 40, 20 being the preferred guide means for use with the different types of guides, namely the wire ropes or stage ropes 30 of the upper guide section 24 and the fixed rails 38 of the workstage guide section 22, respectively.

25 ○ WORKSTAGE GUIDE SECTION 22

As mentioned above, the length of the upper guide section 24 is desirably flexible so as to enable it to extend along with extension of the mineshaft 10. In 30 contrast, the length of the work stage 16 is relatively fixed so no such flexibility (i.e. being extendable/retractable) is necessary for the workstage guide section 22.

35 Additionally, as personnel and materials are unloaded from the conveyance 18 when it is in the work stage 16, it is desirable that the conveyance 18 be oriented consistently at loading/unloading points in the

work stage 16. For this reason, the workstage guide section 22 is rigid and fixed in position relative to the work stage 16. Thus, the skip 18 and cage can be stopped in a consistent position on the workstage guide section 22, with consistent, known orientation to enable fast and efficient loading of rock into the skip and safe egress of personnel and equipment from the cage.

As shown in Figure 3, the workstage guide section 22 comprises a plurality of fixed rails 38 that are rigidly attached at various intervals to the work stage 16. The fixed rails 38 slide in channels 40 (discussed in relation to Figures 8 and 9) so that the skip 18 can advance through the work stage 16.

The channels 40 are necessarily open at one side to enable the skip 18 to slide past connections (not shown) between the fixed rails 38 and the work stage 16.

It is desirable to ensure that the skip 18 is safely mounted to the workstage guide section 22 before it transitions off the end of the upper guide section 24. Consequently, the fixed rails 38 extend a short distance above the connection between the stage ropes 30 (i.e. the upper guide section 24) and the work stage 16 so that guiding of the skip 18 on the fixed rails 38 commences before the stage ropes 30 cease guiding the head section 18' when the conveyance 18 is received therein.

A slight overlap in guidance of the skip 18 by the stage ropes 30 via the head section 18' and guidance of the skip 18 directly by the fixed rails 38 also ensures that the orientation of the skip 18 is at all times controlled.

#### ○ EXCAVATION REGION GUIDE SECTION 26

Although the excavation region guide section 26 constitutes part of the embodiment shown in Figure 1, it will be appreciated that no such guide section 26 may be necessary, and that the upper guide section 24 and lower

or workstage guide section 22 can be provided without also providing the excavation region guide section 26.

Similarly, it may be desirable to provide the excavation region guide section 26 without also supplying  
5 the upper guide section 24 and workstage guide section 22.

The excavation region guide section 26 is extendable and retractable to accommodate movements of the work stage 16 or of components (e.g. the cutting head 14) relative to the work stage 16. In other words, the  
10 excavation region guide section 26 of Figure 1 also constitutes a variable length guide section.

As the cutter head 14 moves away from the workstage 16, the excavation region guide section 26 extends. Similarly, as the workstage 16 moves towards the cutter  
15 head 14, the excavation region guide section 26 retracts.

Enabling the workstage 16 and cutter head 14 to advance at different times can be critical to proper formation of the mine shaft 10. Personnel in the work stage 16 line the mineshaft 10 during excavation of the  
20 mineshaft 10 by the cutting head 14. Thus, the cutting head 14 will advance though the work stage 16 remains stationary. To this end the excavation region guide section 26 has variable length and is extendable without a corresponding extension and/or retraction of the workstage  
25 guide section 22.

In the embodiment shown in Figure 1, the cutting head 14 may advance 10.5m and then cease cutting, at which time the work stage 16 advances 10.5m down the mineshaft 10 towards the cutting head 14 and lining of the next  
30 10.5m section of the mineshaft 10 can commence in the work stage 16. Thus as the cutting head 14 advances the excavation region guide section 26 extends so that the workstage 16 can remain in position until the concrete sets and/or services (e.g. ducting, wiring, etc.) are  
35 installed, and as the workstage 16 advances the excavation region guide section 26 retracts.

Conversely, the excavation region guide section 26

retracts as the upper guide section 24 extends. This is because extension of the upper guide section 24 results in lowering of the work stage 16 towards the cutting head 14. It is noted that the upper guide section 24 extends with  
5 downward movements of the workstage 16 and workstage guide section 22.

The excavation region guide section 26 comprises a telescopic guide assembly including a plurality of telescopic guides, such as telescopic guide 44 as shown in  
10 Figure 5. The telescopic guides 44 ensure there is always a guide extending the full distance between the work stage 16 and cutting head 14 so that a conveyance can be guided between them even as the distance changes. Rotation of the conveyance when travelling along the variable length  
15 lower guide section 26 is undesirable due to the limited space and critical nature of the equipment between and in the work stage 16 and cutting head 14. Thus, telescopic guide systems are preferred as they constrain rotational and lateral/horizontal movement of a conveyance moving  
20 along the guide system, even though the length of the guide system changes. In addition to telescopic guides, other flexible length guides could be used in this section such as ropes, etc.

In traditional shaft sinking operations buckets are  
25 used during mucking to bring blasted rock from out of a mine shaft. Since buckets are round there is no great issue with rotation. In contrast, the conveyances 18 shown herein may have another shape, for example they may have a square or rectangular cross-section, and so rotation is  
30 undesirable. To this end, the excavation region guide section 26 may constitute a system supplied entirely separately from the complete guide system 20 described above, and be designed for fitting to an existing shaft-boring system. Such an excavation region guide section 26  
35 (i.e. variable length guide system) would also be for guiding a conveyance along the mine shaft 10, and would extend from the work stage 16, the excavation region guide

section 26 being extendable or retractable to accommodate changes in distance between the work stage 16 and the lower region 42 of a mineshaft 10.

5 The excavation region guide section 26 as shown in Figure 5 extends to, or in the direction of, a shaft forming apparatus such as cutting head 14, and would thus extend or retract with changes in distance between the work stage 16 and shaft forming apparatus.

10 The telescopic guide 44 of the excavation region guide section 26 comprises an upper rail 46 and a lower rail 48 that is slidably received in a lower end of the upper rail 46. The lower end of the fixed rail 38 is received in the upper end of the upper rail 46. As the cutting head 14 advances the lower rail 48 extends from  
15 the upper rail 46. Conversely, as the work stage 16 advances towards the cutting head 14 the lower rail 48 retracts into the upper rail 46.

20 Since the larger of any two concentrically disposed rails will present an edge against which the channel 40 of the conveyance 18 may snag during raising or lowering (depending on whether the larger diameter rail is the upper or lower rail of the two concentrically disposed rails), the channels 40 are flared on their upper and lower ends.

25 It will be appreciated that the telescopic guide assembly may comprise any number of concentrically disposed rails. For example, the telescopic guide 44 may comprise only a single rail (e.g. upper rail 46) that receives the fixed rail 34 attached to the work stage 16.  
30 As such the fixed rail 34 and upper rail 46 together would form a telescopic guide system 44. Similarly, lower rail 48 may be sized to be received in fixed rail 34, thus omitting upper rail 46.

35 It will also be appreciated that the upper rail 46 may in fact retract up the fixed rail 38 as the work stage 16 advances, and extend from the fixed rail 38 as the cutting head advances provided that there are no

connections between the fixed rail 38 and work stage 16 for a sufficient length at the lower end of the fixed rail 38.

Thus the guide system 20 comprises a variable  
5 length upper guide section 24 extending upwardly from the work stage 16, a fixed length workstage guide section 22 fixed to the workstage 16 intermediate the other guide sections 24, 26, and a variable length lower (i.e. excavation region) guide section 26 extending downwardly  
10 from the workstage 16 towards a lower region in the mineshaft 10.

O SKIP

15 The use of skips 18 (and 64 as described below) as conveyances is particularly advantageous as skips can be filled from the top or side, discharged from the bottom, e.g. using arc gate skips and corresponding latches positioned at the location at which the skips will be  
20 discharged. Contrastingly, buckets must be upended, typically manually, and are thus generally open-topped to enable material to fall out during discharging. To that end, buckets usually have chains hanging from the sides, which make proper alignment of the bucket with, e.g. a  
25 loading/discharge point, more difficult than with skips that are fully guided at all times. Skips are thus a safer and more efficient alternative to buckets.

To enable the skip 18 to travel along the stage ropes 30, the stage ropes 30 run in running bushings 32  
30 provided on a head section 18' (shown in Figures 2 and 3) that receives the skip 18. The head section 18' guides movement of the skip 18 between the upper region 28 of the mine shaft 10 and the work stage 16.

While the skip 18 may have any appropriate  
35 construction, in the present embodiment it is represented by the construction identified with numeral 64 as shown in Figures 8 and 9. In other alternatives, the skip 18 may

comprise another device such as an auxiliary cage 18''. For illustrative purposes such an auxiliary cage 18'' is shown in Figure 2, received in a head section 18', and in Figure 3 in isolation.

5           The head section 18' (which will hereinafter be interchangeably referred to as a "crosshead" or "bridle") receives the auxiliary cage 18'' and assists with guiding the auxiliary cage 18'' along the upper guide section 24 of the guide system 20, as shown in Figure 2.

10           The auxiliary cage 18'' is used for the transportation of personnel (in lower cage 50), but can also be used for the transportation of goods (e.g. vent pipe 41 as shown in upper cage 52 in Figure 2).

15           To transition between the upper guide section 24 and the workstage guide section 22 the head section 18' detaches from the auxiliary cage 18''. To facilitate this separation the upper guide section 24 and workstage guide section 22 meet at a transition region (not shown) where the head section 18' separates from the auxiliary cage  
20 18''.

          The transition region may simply constitute the termination points of the stage ropes 30 and is adapted to halt downward travel of the head section 18' whilst permitting the auxiliary cage 18'' to continue downward  
25 travel along the workstage guide section 22.

          For this reason also it is desirable that there be provided separate guide means on the head section 18' and auxiliary cage 18''. To that end, bushings 32 are provided on the head section 18' to guide the head section  
30 18' along the upper guide section 24, and channels 40 are provided on the auxiliary cage 18'' to guide the auxiliary cage 18'' along the workstage guide section 22 after the head section 18' has chaired against the workstage 16.

          Figures 6 and 7 show side views of a head section  
35 18'. The head section 18' comprises a containing section 54, head charring section 56, base charring section 58, engagement assembly 60, and guide members 62.

In a most rudimentary embodiment, a conveyance guide system for moving a conveyance or skip 18 along a mineshaft, will include a workstage guide section 22, with the skip 18 (which may comprise auxiliary cage 18'' as shown in Figures 2 and 3, skip 64 as shown in Figures 8 and 9, or another type of conveyance) moveable along the workstage guide section 22, an upper guide section 24 located along the mineshaft 10 in series with the workstage guide section 22, and a head section 18' for receiving the conveyance 18. The head section 18' cooperates with the upper guide section 24 to enable the conveyance 64, 18'' to travel from the workstage guide section 22 along the upper guide section 24 when received by the head section 18'. The skip 18 includes a chairing member (e.g. skip chairing section 114) that cooperates with a chairing member (e.g. head chairing section 56) of the head section 18'. The chairing member (e.g. skip chairing section 114) of the skip 64 or auxiliary cage 18'' comes into abutment with the chairing member (e.g. head chairing section 56) of the head section 18', to chair the conveyance 18 in the head section 18'.

Head section 18' is essentially a passive element of the system. It is passive insofar as movement of the head section 18' is afforded by movement of a conveyance 18 against which the head section 18 is chaired, or by downward movement of the work stage 16 when the head section 18' is chaired against the work stage 16. In other words, the head section 18' depends from the conveyance 18 during movement of the conveyance 18 and head section 18' along the first or upper guide section 24.

The containing section 54 is for containing or receiving a conveyance 18, such as skip 64 as discussed below or auxiliary cage 18'' as described above. The containing section 54 guides movement of the conveyance 18 during movement between the work stage 16 and an upper level (e.g. ground level) of the mineshaft 10.

The containing section 54 is bounded by four

vertical and substantially parallel corner posts 66 the ends of which are interconnected by beams. The beams include a group of four horizontal beams 68 in the region of the head chairing section 56 and a similar group of four horizontal beams 70 in the region of the base chairing section 58. The corner posts 66, and beams 68, 70 together define substantially rectangular sides, top and bottom of the containing section 54.

It will be seen from the different widths of the head section 18' as shown in Figures 6 and 7, that the groups of horizontal beams 68, 70 each include two shorter beams and two longer beams, such that the top and bottom of the containing section 54 are substantially rectangular. Consequently, the containing section 54 has two short sides and two long sides being the sides across which the short beams and long beams respectively extend.

The posts 66 and beams 68, 70 may be formed from any appropriate material and are presently formed from rectangular hollow section steel that is capped at the ends to avoid internal debris hang-up.

The containing section 54 further includes brace beams 72 extending between the corner posts 66, generally in the plane of the rectangular sides of the containing section 54, at points intermediate the ends of the corner posts 66. In the present embodiment the beams 72 are substantially horizontal and parallel with the beams 68, 70. The beams 72 are equidistantly spaced between the head chairing section 56 and the base chairing section 58, and are connected at their ends to the vertical corner posts 66 by bolts 74.

On the longer sides of the containing section 54 (as shown in Figure 6), pairs of diagonal struts 76 extend from opposite sides (above and below) of one end of one beam 72 to the opposite end of the next beam 72 vertically above and below. Only one such diagonal strut 76 extends from the topmost and bottommost beams 72, as those beams 72 have only one neighbouring beam 72 that is respectively

below and above the beam 72 in question. Together, the beams 72 and struts 76 resist the containing section 54 forming a mechanism (i.e. resists relative rotation of structural members 66, 68, 72 and 76 about bolts 74), thus providing structural rigidity to the containing section 54.

On the short sides of the containing section 54 (as shown in Figure 7) there are no such diagonal struts.

The number of beams 72 and struts 76 may be selected as appropriate and may, for example, include 2 or more beams 66 with a corresponding number of struts 76.

The posts 66, beams 68, 70, 72 and struts 76 are each oriented and/or shaped to discourage debris collection. For example, the brace beams 72 and diagonal struts 76 may be formed from standard angle section steel opening inwardly of the containing section 54. Since debris will typically fall around the containing section 54 rather than through it, the angle section is unlikely to gather debris.

The posts, beams 68, 70, 72 and struts 76 together constitute a structural latticework or structural interconnection forming the containing section 54. These structural members define a volume of the containing section 54 in which goods, conveyances and mined material can travel in an appropriate receptacle or skip. To provide the requisite strength, the structural members are preferably made from steel, but may alternatively be made from other materials such as aluminium for some applications.

Extending up the inside of the containing section 54 are guides 55 for guiding progress of a conveyance 18 into and out of the containing section 54 (described below). The guides 55 are of the same shape as guides of the second or workstage guide section 22. The guides 55 of the present embodiment are formed from angle-section steel extending up the inside of the containing section 54 in the corners. The angle-section steel aligns with (i.e.

becomes coextensive or collinear with) the same size and gauge angle-section steel extending downwardly into the work stage 16 and constituting part of the workstage guide section 22. The guides 55 and workstage guide section 22  
5 are consistently shaped and come into alignment when the head section 18' chairs against the work stage 16, to provide a consistent guide path for the skip 18 moving into or out of the containing section 54. The head chairing section 56 is for chairing against the skip 18,  
10 so that the head section 18' and conveyance 18 travel in abutment upwardly from the work stage 16 along the upper guide section 24. The head chairing section 56 provides a rigid structural frame from which the weight of the head section 18' can depend during travel upwardly from the  
15 work stage 16.

The head chairing section 56 is bounded at the sides by the corner posts 66, at the top by beams 68 and head chairing bars 77 and, across the long sides of the containing section 54, cross members 78. Across the  
20 shorts sides of the containing section 54 the head chairing section 56 is bounded by cross members 80. Cross members 80 extend across the short sides of the containing section 54 at a level slightly higher than cross members 78, so as to be spaced a distance from the next lower beam  
25 72 that is the same as the distance between that beam 72 and the next lower beam 72.

The head chairing section 56 abuts or "chairs" against the conveyance 18 when the conveyance 18 is hoisted from the work stage 16 into the containing section  
30 54. After the conveyance 18 has chaired against the head chairing section 56, the head section 18' travels with the conveyance 18 as it is hoisted upwardly along the upper guide section 24 away from the work stage 16.

The head chairing bars 77 are positioned  
35 symmetrically about a centre axis Y of the containing section 54. This symmetrical positioning ensures that the conveyance 18 is centred in the head section 18' during

ascent up the upper guide section 24. The head chairing bars 77 extend substantially perpendicularly between the beams 68 that extend across the long sides of the containing section 54, substantially in parallel with the beams 68 that extend across the short side of the containing section 54. The head chairing bars 77 support upper ends of diagonal chairing bars 82 that extend between the head chairing bars 77 and the cross members 78. The diagonal chairing bars 82 chair against the top of the conveyance 18 as discussed below (described below in relation to Figures 10 and 11).

As best seen in Figure 7, the diagonal chairing bars 82 are paired, with a pair of diagonal chairing bars 82 positioned towards each end of a respective head chairing bar 77, symmetrically about the centre axis Y of the containing section 54.

Impact liners 84 are attached to the diagonal chairing bars 82 by any appropriate means, to reduce the impact of a conveyance 18 as it chairs against the diagonal chairing bars 82. In a preferred embodiment, the impact liners each constitute a sleeve for receiving a respective diagonal chairing bar 82 before attachment of the diagonal chairing bar 82 to the head chairing bars 77 and cross members 78. The impact liners 84 are positioned on the undersides of the diagonal chairing bars 82. While in the present case each diagonal chairing bar 82 is provided with an individual impact liner 84, a single impact liner 84 may extend across the underside of more than one diagonal chairing bar 82. For example, a single impact liner 84 may extend across the undersides of the two diagonal chairing bars 82 of a particular pair of diagonal chairing bars 82.

The impact liners 84 may be formed from any appropriate material, such as rubber, neoprene or a soft metal. The impact liners 84 may instead not be designed to absorb much, if any, impact and may instead be formed from a long-wearing material. To accommodate the absence

of a shock absorber on the diagonal chairing bars 82, the hoisting speed of the conveyance 18 may be slowed to a "creep speed", being a speed at which chairing will not cause a significant amount of vibration through the head section 18'.

The use of impact liners 84 is preferable as they remove the need to slow the conveyance 18 down to a "creep speed". Accordingly, the time required for the conveyance 18 to traverse the shaft is reduced, which in turn adds to the overall increase in muck removal speed and hence shaft sinking speed.

The base chairing section 58 is for chairing against the work stage 16 after the head section 18' has descended thereupon. In practice, the head section 18' will chair against the work stage 16 as the skip 18 travels from the upper guide section 24 along the workstage guide section 22. Upon chairing, or slightly before chairing, of the head section 18' on the work stage 16, the skip 18 is released from the head section 18' to continue down through the work stage 16 for unloading and/or loading.

The base chairing section 58 is bounded at its corners by the vertical posts 66, at the bottom generally by beams 70, and at the top by cross members 86. Cross members 86 extend across the sides of the containing section 54 between corner posts 66 to which the cross members 86 are bolted. The base section 58 in effect provides a rigid structural impact frame for supporting the weight of the head section 18' when chaired against the work stage 16.

The base chairing section 58 includes four guide plates 90 extending from the corner posts 66 on the opposite short sides of the head section 18', substantially perpendicularly outwardly from the short sides. Each guide plate 90 is planar and lies in a vertical plane, the respective plate 90 tapering upwardly towards a respective corner post 66.

The base chairing section 58 is also provided with impact buffers or stops 88 depending downwardly from the lower ends of the vertical corner posts 66. The impact buffers or stops 88 reduce the impact or impulse load as the head section 18' chairs against the work stage 16.

The impact buffers or stops 88 may be mounted to the corner posts 66 (or along beams 70 if desired) by any appropriate means. Presently, the impact buffers or stops 88 comprise a small square tab of rubberised shock absorber material moulded onto a plate (not shown) from which a bolt (not shown) protrudes. The bolt extends through an aperture in the end capping of the corner post 66 or other aperture, and is secured in position by tightening a nut (not shown) onto the bolt.

Since the work stage 16 will typically be provided with rubber impact liners (described below) there may be no need to provide impact buffers or stops 88.

During movement the head section 18' is guided along the upper guide section 24. To that end, the head section 18' is provided with two pairs of guide rope bearings 92. One guide rope bearing 92' of each pair of guide rope bearings 92 is welded or otherwise attached to the head section 18' at the head chairing section 56. The other guide rope bearing 92'' of the respective pair of guide rope bearings 92 is welded or otherwise attached to the head section 18' at the base chairing section 58.

Each guide rope bearing 92', 92'' comprises a roller set 96 that runs along the stage ropes (designated by broken line Z) of the upper guide section 24. The roller set 96 is fixed to a mount 94 for mounting the respective roller set 96 to the containing section 54.

Each mount 94 comprises a U-shaped bent plate, with the ends of the arms of the U-shape attached (e.g. welded) to the containing section 54, and the respective roller set 96 attached (e.g. welded) to the base of the U-shape. Other types of mount will be suitable in particular circumstances, or no mount at all in cases where the

roller sets 96 are mounted directly to the containing section 54, and all such variations are intended to fall within the scope of the present disclosure.

Each roller set 96 comprises a plurality of annular  
5 rollers (not shown) housed in a cylindrical housing 98. The housing 98 comprises two halves hinged together so that the housing 98 can be closed around a stage rope Z when installing a head section 18'.

A tapered (e.g. torpedoed) plate 110 is attached to  
10 the outside of the housing 96. As the head section 18' travels upwardly into the mineshaft conveyance system 100, the plates 110 enter female guides (not shown) to stabilise the head section 18'.

It will be appreciated that the guide rope bearings  
15 92 may be substituted for another guide mechanism (e.g. replaceable bronze bushings and/or spear guide slippers) to suit a different type of upper guide section 24 (e.g. rails mounted in the lining of the mineshaft).

The head section 18' is thus configured so that  
20 the hoist rope extends through the head section 18' to the skip 18. Therefore, as the skip 18 chairs in the head section 18' on its upward path, both the head section 18' and skip 18 are lifted up the mineshaft 10 by the hoist rope pulling on the conveyance 18.

It will be appreciated that all of the various  
25 interconnected members (e.g. members 66, 68, 70, 72) may be connected by nuts and bolts, welding, pairs of clamping plates, and other attachment methods all of which may be used and are intended to fall within the scope of the  
30 present disclosure. Moreover, those members may be formed from any appropriate material having any appropriate cross-section.

The latch 60 is a 'Kimberley' type safety latch,  
though any appropriate latch may be used. The latch  
35 includes an eyelet 124 mounted to the cross members 86 on both long sides of the containing section 54. A lever 126 is pivotally mounted in the eyelet 124 to pivot between a

latched position (not shown, but where the arm of the lever 126 is horizontal) and an unlatched position as shown. The lever 126 is biased to the latched position by a spring canister 130 that extends from a diagonal strut 76 to about mid-way along the arm of the lever 126.

The lever 126 is shaped so that in its 'at rest' position it is latched. A latched position while at rest is achieved by the lever arm 126 being at an angle (presently 90°) to the catch 128, rather than being aligned with (i.e. at 180°) the catch 128, so that as the lever 126 descends under its own weight the catch 128 is rotated against a pin 132 (see Figure 6) of the skip 18 (presently skip 64, which is an arc gate skip, though it will be appreciated that the disclosure below can be similarly applied to other types of skip 18, such as auxiliary cage 18'') thereby to catch the pin 132.

Figures 8 and 9 show a skip 64 for conveying mined material from a work stage 16 to a dump in the region of the top of the mine shaft hoist system 100. Skip 64 includes a frame 112 bounding a receptacle that contains the mined material during conveyance thereof.

At the top of the frame is a skip chairing section 114. The skip chairing section 114 forms part of the frame 112 and comprises diagonal plates 116 set at an angle the same as that of the diagonal chairing bars 82.

From the apex of the skip 64, namely where the diagonal plates 166 meet, a cable sheath 118 extends. The cable sheath 118 attaches to the lower end of a hoist rope 120 thereby attaching the rope 120 to the skip 64. The hoist rope 120 is hoisted by the mine shaft hoist system 100 to raise and lower the skip 64 along the mineshaft (e.g. along the workstage guide section 22 and upper guide section 24).

The skip 64 further includes runners 122. The runners 122 run against guides 55 as the skip 64 moves into and out of the containing section 54. The runners 122 comprise angle-section wear plates extending around

and protruding from the corners of the frame 112. It will be appreciated, however, that the runners 122 may comprise a series of rollers or any other mechanism suitable for cooperating with guides 55 to ensure the skip 64 is  
5 appropriately aligned with the head section 18 when entering/exiting the containing section 54.

An "in-use" case of the head section 18' and skip 64 is shown in Figures 10 and 11 which show the skip 64 contained within the containing section 54 of the head  
10 section 18'. As shown in Figure 11, during ascent from the work stage 16 or descent towards the work stage 16 the diagonal chairing plates 116 of the skip 64 are chaired (i.e. in abutment) with the impact liners 84 of the head section 18'. Since the runners 122 in the corners of the  
15 skip 64 are in abutment with the guides 55 of the containing section 54, the skip 64 remains in alignment with the head section 18'.

The rope sheath 118 extends between the head chairing bars 77, so that the hoist rope 120 raises and  
20 lowers both the skip 64 and head section 18' together. In this sense, the head section 18' in effect hangs from the skip 64 whilst in transit.

At the top of the hoist system 100 the plates 110 of the guide rope bearings 92 are received in female  
25 guides to stabilise the head section 18' and thereby also stabilise the skip 64. An arc gate door 134 then opens to release mined material from the skip 64. The arc gate door 134 then closes, readying the skip 64 for descent.

Upon commencing descent, the plates 110 of the  
30 guide rope bearings 92 slide out of the female guides and the skip 64 continues down the upper guide section 24. During descent the head section 18' hangs from the skip 64 by virtue of the abutment between the diagonal plates 116 of the skip 64 and diagonal chairing bars 82 of the head  
35 section 18'. Thus, the rate of descent of the head section 18' is that of the skip 64.

On approaching the work stage 16, the latches 60

are moved to the unlatched position by a trigger 136 mounted to the work stage 16. The trigger 136 is in the form of a bent plate. The plate of the trigger 136 extends vertically upwardly from the work stage 16 and has a bend so that the top section 138 of the trigger 136 is at an angle to vertical, extending away from the head section 18'.

During descent, the head section 18' and skip 64 are latched together, with the lever arm 126 of the latch 60 extending horizontally and protruding from the short side of the containing section 54. As the head section 18' approaches the work stage 16, the lever arm 126 comes into abutment with the top section 138 of the trigger 136. As the head section 18' descends further, the top section 138 of the trigger 136 overcomes the bias of the spring canister 130, and pushes the lever arm 126 into the unlatched position. Since the head section 18' effectively 'hangs' from the skip 64, the head section 18' travels further down towards the work stage 16 in unison with the skip 64 even after the skip 64 has been unlatched from the head section 18'.

Shortly before the head section 18' chairs against the work stage 16 the rate of descent slows to 'creep speed' and the chairing plates 90 of the head section 18' are received in female guides (not shown) on the work stage 16. This ensures the head section 18' is properly aligned with the work stage 16, thus ensuring the guides 55 are aligned with the workstage guide section 22 in the work stage 16.

The head section 18' then comes to rest against an impact liner mounted to the work stage 16. At this point the skip 64 slides along guides 55 out of the head section 18' and onto the workstage guide section 22. In so doing the cable shroud or sheath 118 and rope 120 descend between the head chairing bars 77 and down through the volume of the containing section 54.

It will be understood that at all times when the

skip 64 is within the work stage 16, the cable extends between the head chairing bars 77 through the containing section 54.

After the skip 64 has been filled and is ascending, the skip 64 travels from the workstage guide section 22 into the containing section 54, along the guides 55. The rate of ascent of the skip 64 immediately before chairing with the head section 18' is slowed to 'creep speed' so as to ensure chairing is a controlled event. Once the diagonal chairing plates 11 of the skip 64 have chaired against the diagonal chairing bars 82 of the head chairing section 56 of the head section 18', with the cable sheath 118 positioned centrally between the head chairing bars 77, the rate of ascent of the skip 64 increases.

Immediately after the head section 18' is picked up by the skip 64, the tip of the lever arm 126 travels upwardly against the vertical part of the trigger 136. Once the tip of the lever arm 126 reaches the bend it begins to move along the top section 138 of the trigger 136. At this time the spring canister 130 urges the lever arm 126 progressively back towards into latched position as the head section 18' and skip 64 ascend.

Thus, the skip 64 and head section 18' automatically latch together to ascend from the work stage 16 towards the top of the mineshaft hoist system 100 for dumping of the contents of the skip 64.

The head section 18' is therefore only capable of ascent or descent in unison (i.e. when chaired) with the skip 64. The head section 18' is essentially a passive construction that enables the skip 64 to smoothly transition between a rigid, fixed guide system such as workstage guide section 22, and a variable length guide system, such as stage ropes constituting part of the upper guide section 24. In effect, the head section 18' constitutes a travelling guide frame that is picked up by the skip 64 when the skip 64 travels along the upper guide section 24, the head section 18' acting as an interface

between the skip 64 and the guides of the upper guide section 24. The skilled person will appreciate that latches 60 constitute, in many cases, a safety precaution only since the position of the head section 18' on the skip 64 is set by the interaction between guides 55 and runners 122 and the chairing of the diagonal chairing bars 82 of the head section 18' on the diagonal plates 116 of the skip 64.

Figures 12 to 14 show an alternative version of the head section 142 and a conveyance 140 for conveying both parts and personnel up and down the mineshaft.

The head section 142 comprises a frame 144 having a square horizontal cross-section. The frame 144 comprises an interconnection of horizontal and diagonal struts, and brackets together constituting a rigid structure. The frame 144 is open on one side to facilitate access to a parts conveyance section 146 on top of a personnel carrier portion 148 of the conveyance 140.

The frame 144 again includes corner posts 150 formed from angle-section steel and bearings 92', 92'' as discussed above in relation to head section 18'.

The head section 142 comprises flat head chairing bars 152 against which the conveyance 140 chairs during movement of the conveyance 140 between the work stage 16 and the top of the mineshaft hoist system 100. The flat head chairing bars 152 and head section operate in the same manner as head section 18', and the features of head section 142 will be understood from the discussion above in relation to head section 18'.

The parts conveyance section 146 of the conveyance 140 is bounded by four corner posts 154. An upper end 156 of each corner post 154 is tapered or angled inwardly to assist with alignment of the corner posts 154 with the angle-section of the corner posts 150. To reduce friction between the corner posts 154 of the conveyance 140 and the corner posts 150 of the head section 142, wear plates 158 are fixed at the top and bottom of the parts conveyance

section 146 in pairs. The wear plates 158 of each pair bear against opposite flanges or arms of the angle-section of the corner posts 150 of the head section 142 in use.

5 The wear plates may be secured together using any appropriate method and may be formed from any appropriate material.

The conveyance 140 includes a chairing block 160. The chairing block 160 comprises a pair of chairing bars 162 attached to the top of the conveyance 140 and  
10 positioned to chair against chairing bars 152 of the head section 142, and a cable block 164 that extends between the head chairing bars 152 of the head section 142 when the conveyance 140 is chaired in the head section 142. The cable block 164 is flared outwardly downwardly to  
15 assist with aligning the cable block 164 centrally between the head chairing bars 152 of the head section 142, thereby locating the chairing bars 162 of the conveyance 140 on the head chairing bars 152 of the head section 142.

The personnel carrier portion 148 depends  
20 downwardly from the parts conveyance section 146. The length of the parts conveyance section 146 is the same as that of the head section 142 so that the personnel carrier portion 148 is below the bottommost beam 166 of the head section 142 while the head section 142 and conveyance 140  
25 are travelling together.

The personnel carrier portion 146 includes work stage guides, in the form of female guide brackets 168, that travel along the first guide section 22. In contrast to the head section 18' and skip 64 arrangement described  
30 above, the guides (i.e. corner posts) 144 of the head section 142 do not become coextensive with the first guide section 22. Instead, as the conveyance 140 moves into or out of the head section 142 the corner posts 154 are guided into the head section 142 by corner posts 150 of  
35 the head section 142. When the conveyance 140 travels along the workstage guide section 22 extending in the work stage 16, the female guide brackets 168 slide along

guides, presently C-section steel with the open side of the C-section facing away from the conveyance 140, of the workstage guide section 22.

5 While no latch is shown in the present embodiment, it will be appreciated that a latch or other coupling will be used to couple conveyance 140 to the head section 142. In fact, particularly where a conveyance carries personnel it will often be a legal requirement to have such a safety precaution installed to ensure there exists a mechanical  
10 coupling between the head section 142 and conveyance 140.

At the top of the hoist system 100 the plates 110 of the guide rope bearings 92 are received in female guides to stabilise the head section 142 and thereby also stabilise the conveyance 140. Personnel and materials can  
15 then be loaded into or taken out of the conveyance 140.

Upon commencing descent, the plates 110 of the guide rope bearings 92 slide out of the female guides and the conveyance 140 continues down the upper guide section 24. During descent the head section 142 hangs from the  
20 conveyance 140 by virtue of the abutment between the chairing bars 162 of the conveyance 140 and top chairing bars 152 of the head section 142. Thus, the rate of descent of the head section 142 is that of the conveyance 140.

25 Shortly before the head section 142 chairs against the work stage 16 female chairing brackets 170 of the head section 142 are received over male stubs (not shown) on the work stage 16. Shortly before the head section 142 chairs against the work stage 16 the female guide brackets  
30 168 are received over the end of the male guides of the workstage guide section 22 extending upwardly a short distance from the work stage 16. The bottom of the female guide brackets 168 is flared outwardly so as to accommodate a small degree of misalignment of the female  
35 guide brackets 168 with the guide of the workstage guide section 22.

The lower female guide brackets 168 receive the

upwardly extending male portion of the workstage guide section 22 and, as the conveyance 140 is progressively lowered, the upper female guide brackets 168 eventually receive over the upwardly extending male portion of the workstage guide section 22.

Immediately before the conveyance 140 and head section 142 having been lowered until the head section 142 comes into contact with the work stage, female chairing brackets 170 of the head section 142 receive over the male stubs (not shown) on the work stage 16. This ensures the head section 142 is properly aligned with the work stage 16.

At this time, the head section 142 comes to rest against an impact liner mounted to the work stage 16. At this point the conveyance 140 slides along guides (constituting corner posts 150) out of the head section 142 and onto the workstage guide section 22. In so doing the cable shroud or sheath 118 and rope 120 descend between the head chairing bars 152 and down through the volume of the head section 142.

The chairing process may occur while the conveyance 18 progresses downwardly into the work stage 16 at substantially the same speed at which the conveyance 18 descended the first guide section 24. Alternatively, the conveyance 18 may be slowed slightly before the head section 142 chairs against the work stage 16. In both of these examples, impact liners may be provided to reduce the impact loading of the head section 142 against the work stage 16. As a further alternative, the conveyance 18 may be slowed to a 'creep speed' in advance of the head section 142 chairing against the work stage 16.

It will be understood that at all times when the conveyance 140 is within the work stage 16, the cable extends between the head chairing bars 142 through the head section 142.

After the conveyance 140 has been filled and/or its load has been deposited, and the conveyance 140 is

ascending, the conveyance 140 travels from the workstage guide section 22 into the head section 142, along the guides (corner posts 150). The rate of ascent of the conveyance 140 immediately before chairing with the head section 142 is slowed to 'creep speed' so as to ensure chairing is a controlled event. Once the chairing bars 162 of the conveyance 140 have chaired against the top chairing bars 152 of the head section 142, with the cable sheath 118 positioned centrally between the head chairing bars 152, the rate of ascent of the conveyance 140 increases.

The head section 142 is therefore only capable of ascent or descent in unison with (i.e. when chaired upon) the conveyance 140. The head section 142 is essentially a passive construction that enables the conveyance 140 to smoothly transition between a rigid, fixed guide system such as workstage guide section 22, and a variable length guide system, such as stage ropes constituting part of the upper guide section 24. In effect, the head section 142 constitutes a travelling guide frame that is picked up by the conveyance 140 when the conveyance 140 travels along the upper guide section 24, the head section 142 acting as an interface between the conveyance 140 and the guides of the upper guide section 24.

Lastly, multiple conveyances may concurrently operate in the shaft. The first and second guide sections of the conveyance system may guide each of the multiple conveyances. Personnel and/or materials may be transported in a different one or ones of the conveyances to one or more conveyances that transport mined material.

In the claims which follow and in the preceding description of the invention, except where the context requires otherwise due to express language or necessary implication, the word "comprise" or variations such as "comprises" or "comprising" is used in an inclusive sense, i.e. to specify the presence of the stated features but not to preclude the presence or addition of further

features in various embodiments of the invention.

It is to be understood that, if any prior art  
publication is referred to herein, such reference does not  
constitute an admission that the publication forms a part  
5 of the common general knowledge in the art, in Australia  
or any other country.

Claims

1. A conveyance system for moving a conveyance along a mine shaft during shaft construction, comprising:
  - a first guide section;
  - a second guide section located along the mineshaft in series with the first guide section, the conveyance being movable along the second guide section; and
  - a head section for receiving the conveyance, the head section cooperating with the first guide section such that when the head section receives the conveyance, the head section enables the conveyance to travel from the second guide section along the first guide section;wherein the head section ceases travel once it reaches the second guide section.
2. A conveyance system according to claim 1, wherein the conveyance is a skip.
3. A conveyance system according to claim 1 or claim 2, wherein the head section includes a containing section in which the conveyance is at least partially received during travel of the conveyance along the first guide section.
4. A conveyance system according to any one of claims 1 to 3, wherein the head section includes a chairing member that chairs against the conveyance during travel of the conveyance along the first guide section.
5. A conveyance system according to claim 4, wherein the chairing member comes into abutment with the conveyance.
6. A conveyance system according to any one of claims 1 to 5, wherein the head section is configured to depend from the conveyance during movement of the conveyance and head section along the first guide section.

7. A conveyance system according to any one of claims 1 to 6, wherein the head section is configured to permit passage of a hoist rope attached to the conveyance by which the conveyance is lifted and/or lowered along the mineshaft.

8. A conveyance system according to claim 7, wherein the head section is arranged so that the hoist rope can extend through the head section to the conveyance.

9. A conveyance system according to any one of claims 1 to 8, wherein the head section chairs against a work stage as the conveyance travels from the first guide section along the second guide section.

10. A conveyance system according to any one of claims 1 to 9, wherein the mineshaft is substantially vertical.

11. A conveyance system according to any one of claims 1 to 10, wherein the first guide section is a variable length guide section and the second guide section is a fixed length guide section.

12. A conveyance system according to any one of claims 1 to 11, wherein the first guide section and second guide section restrict rotational movement and swing movement of the conveyance.

13. A conveyance system according to claim 12, wherein the first guide section and second guide section substantially prevent rotational movement and swing movement of the conveyance.

14. A conveyance system according to any one of claims 1 to 13 for concurrently guiding multiple conveyances.

15. A conveyance system according to claim 14, wherein

the first and second guide sections guide each of the multiple conveyances.

16. A conveyance system according to claim 14 or 15, wherein personnel and/or materials are transported in a different one or ones of the conveyances to one or more conveyances that transport mined material.

17. A guide system for guiding a skip during shaft sinking, while lifting and/or lowering of the skip in a mineshaft, the guide system comprising:

an intermediate fixed length guide section for guiding movement of the skip within a work stage and along the mineshaft, the work stage being arranged for transferring cuttings passed upwardly and received from a shaft forming apparatus to the skip for ascending the mineshaft to an upper region of the mineshaft; and

a variable length upper guide section extending from the intermediate fixed length guide section to accommodate changes in distance between the intermediate fixed length guide section and an upper region of the mineshaft, the variable length upper guide section guiding movement of the skip between the upper region of the mineshaft and the work stage,

wherein the guide system restricts rotational movement and swing movement of the skip; and

wherein the guide system provides guidance along an entire length of the mineshaft from the shaft forming apparatus to the upper region of the mineshaft.

18. A guide system according to claim 17, wherein the intermediate fixed length guide section and the variable length upper guide section are configured to allow the skip to transition from one guide section to the other.

19. A guide system according to any one of claims 17 to 18, wherein the variable length upper guide section

extends from the intermediate fixed length guide section to the upper region of the mineshaft.

20. A guide system according to any one of claims 17 to 19, wherein the intermediate fixed length guide section is fixable to the work stage.

21. A guide system according to any one of claims 17 to 20, further including a variable length lower guide section extending from the intermediate fixed length guide section to accommodate changes in distance between the intermediate fixed length guide section and a lower region of the mineshaft.

22. A guide system according to claim 21, wherein the variable length lower guide section extends from the intermediate fixed length guide section in the direction of a shaft forming apparatus.

23. A guide system according to claim 21, wherein the variable length lower guide section extends to the shaft forming apparatus.

24. A guide system according to claim 21 or 22, wherein the variable length lower guide section extends with movements of the shaft forming apparatus away from the intermediate fixed length guide section, and retracts with movements of the intermediate fixed length guide section towards the shaft forming apparatus.

25. A guide system according to any one of claims 21 to 23, wherein the variable length lower guide section comprises a telescopic guide assembly.

26. A guide system according to claim 25, wherein the telescopic guide assembly comprises a plurality of concentrically disposed rails.

27. A guide system according to any one of claims 21 to 25, wherein the variable length lower guide section is extendable without a corresponding extension and/or retraction of the variable length upper guide section.

28. A guide system according to any one of claims 21 to 26, wherein the variable length lower guide section retracts as the variable length upper guide section extends.

29. A guide system according to any one of claims 17 to 28, wherein the variable length upper guide section extends with downward movements of the intermediate fixed length guide section.

30. A guide system according to any one of claims 17 to 29, wherein the intermediate fixed length guide section comprises one or more fixed length rails.

31. A guide system according to claim 29, wherein the variable length upper section extends from the intermediate fixed length guide section to an above ground loading/discharge region.

32. A guide system according to any one of claims 17 to 31, wherein the variable length upper guide section comprises one or more ropes.

33. A guide system according to claim 32, wherein the or each rope winds around a sheave, the sheave rotating to extend and retract the respective rope.

34. A guide system according to any one of claims 17 to 33, wherein the variable length upper guide section and intermediate fixed length guide section meet at a transition region, and the conveyance comprises a head

section and a base section, the transition region being adapted to halt downward travel of the head section whilst permitting the base section to continue downward travel along the intermediate fixed length guide section.

35. A guide system according to any one of claims 17 to 34, being for use in a substantially vertical mineshaft.

36. A mine shaft conveyance system comprising a guide system according to any one of claims 17 to 35, and a hoist system for lifting and/or lowering the conveyance along the guide system.

1/5

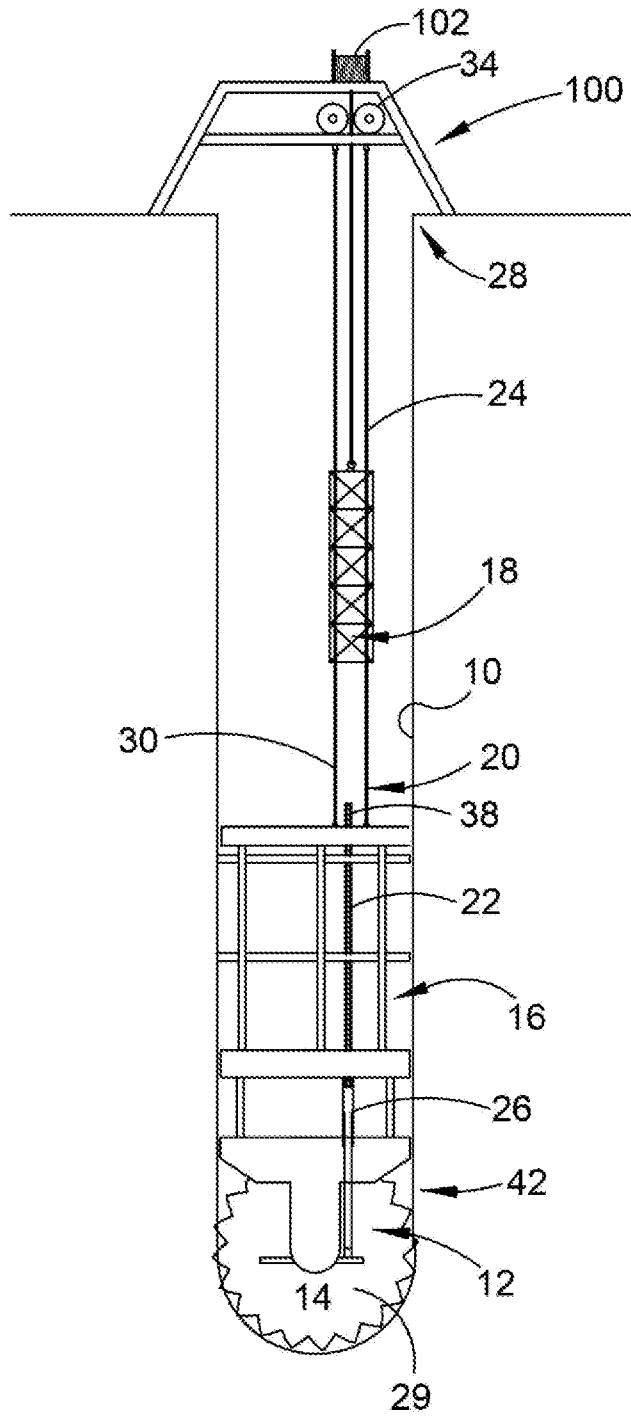

FIGURE 1

2/5

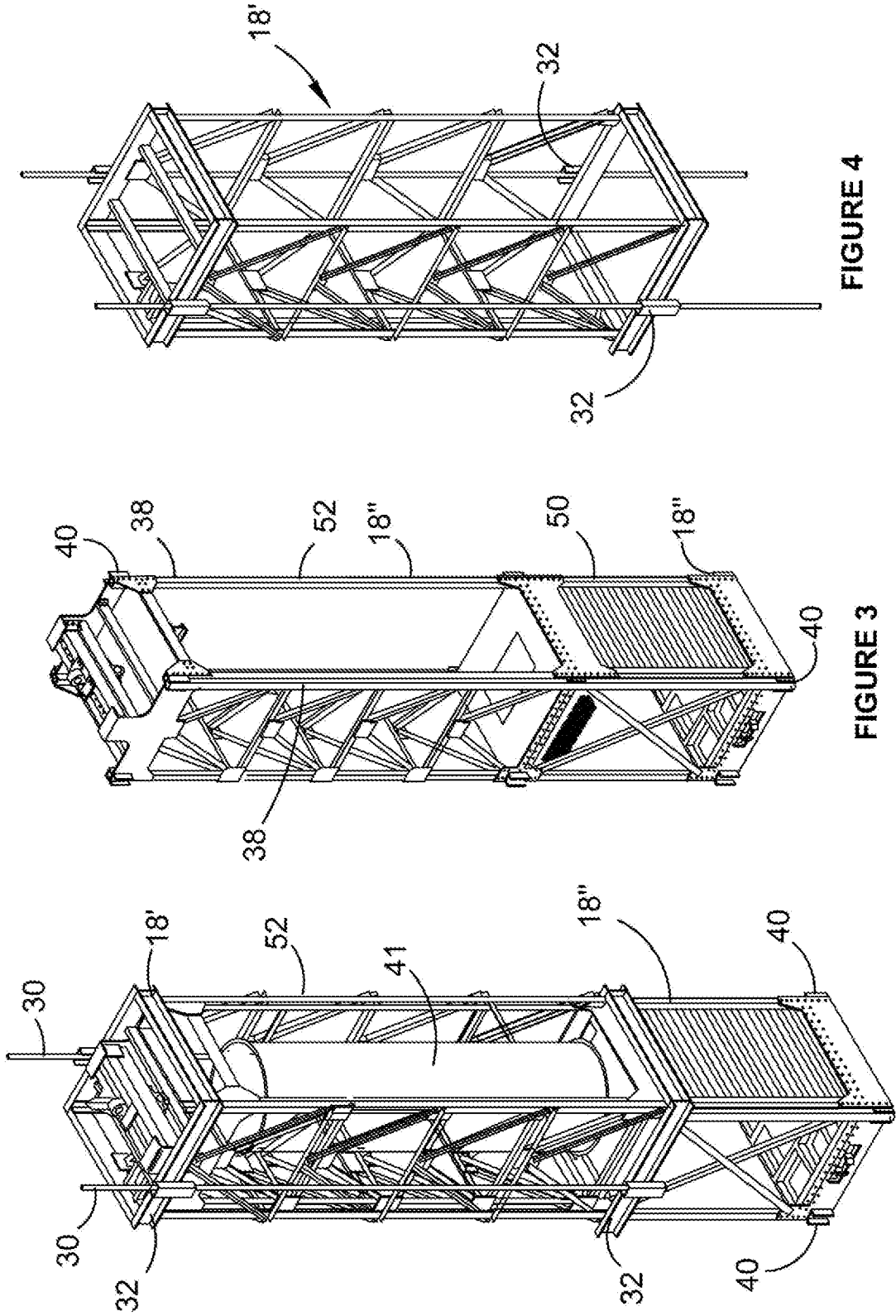

FIGURE 4

FIGURE 3

FIGURE 2

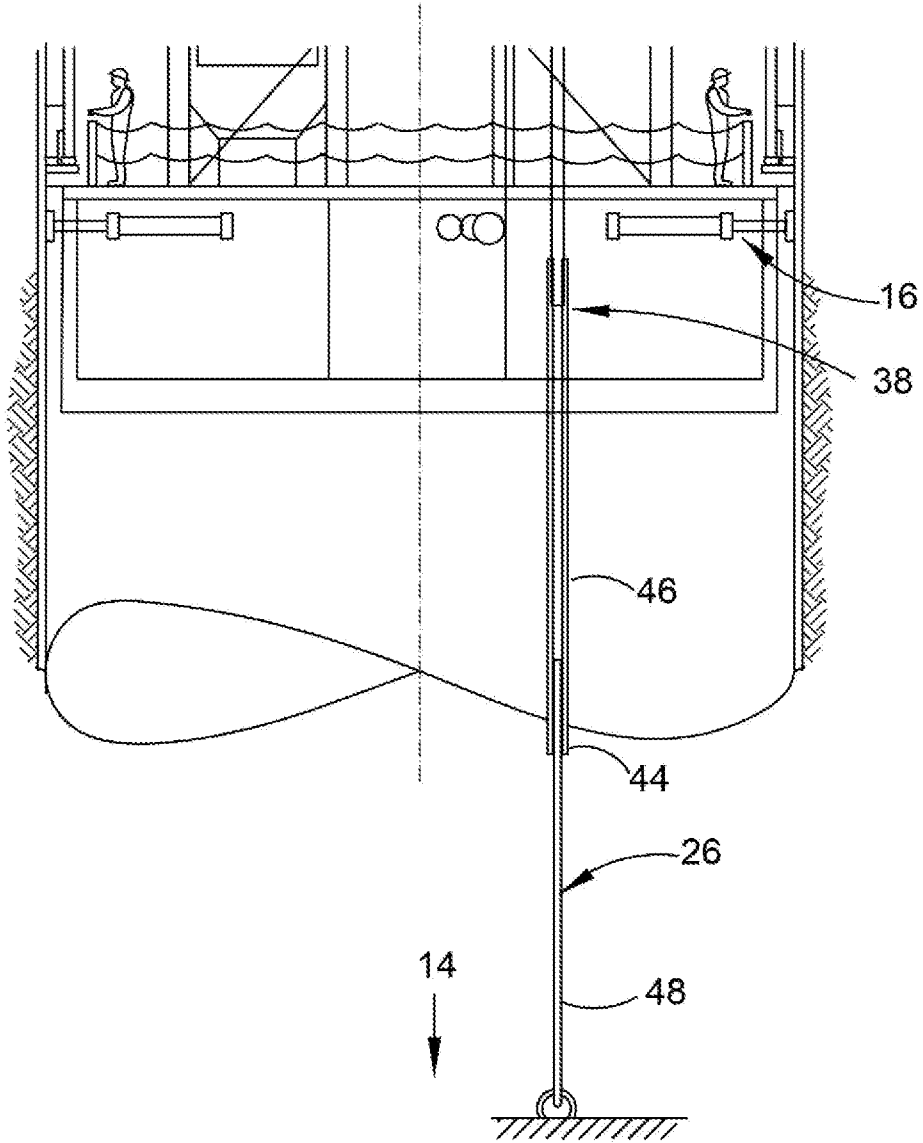

FIGURE 5



5/5

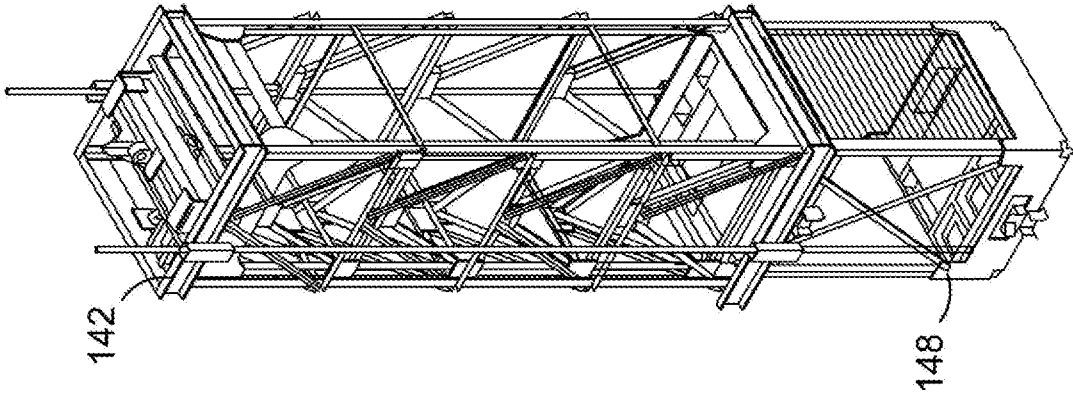

FIGURE 14

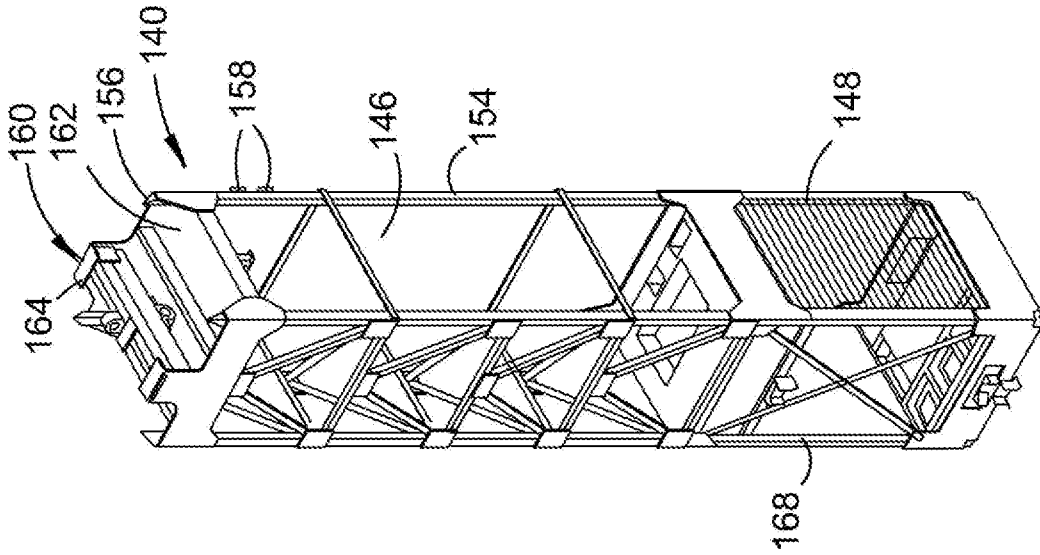

FIGURE 13

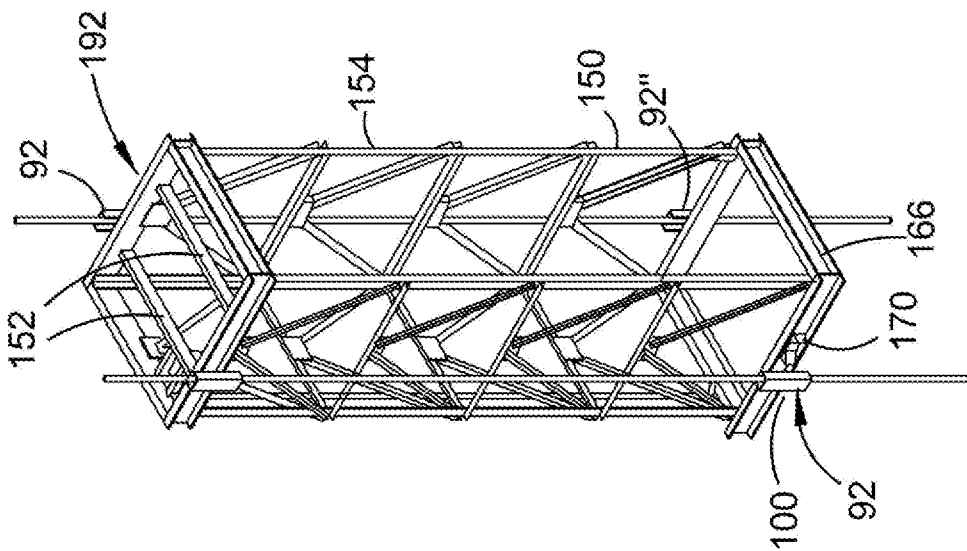

FIGURE 12

