

(No Model.)

A. E. BROWN.  
FURNITURE CASTER.

No. 455,906.

Patented July 14, 1891.

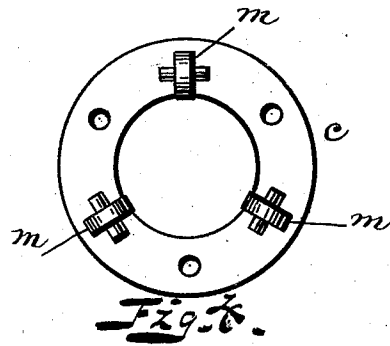
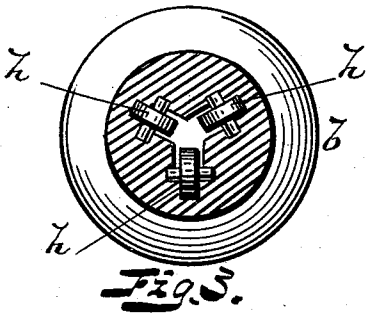
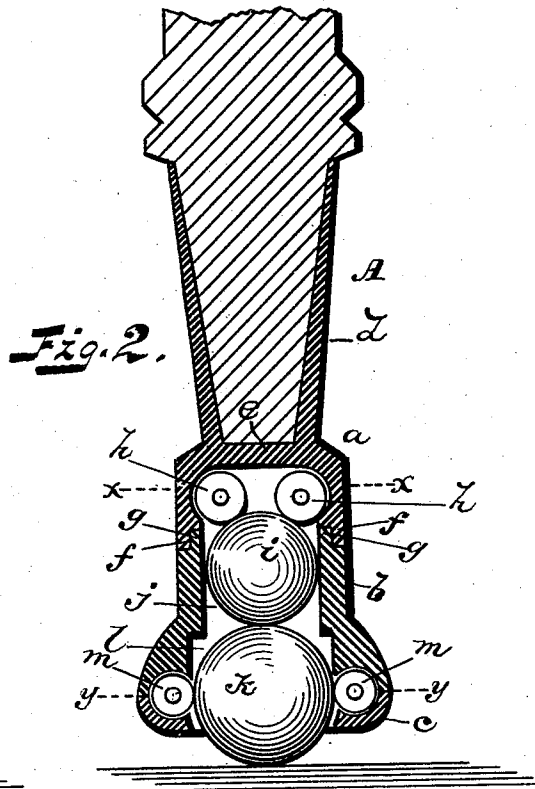
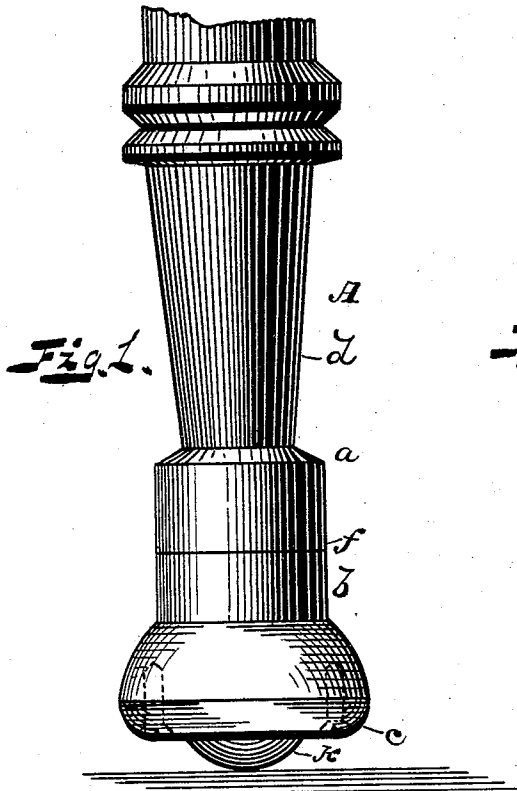

WITNESSES.  
*Jas B. Clarke*  
*m. m. martin*

INVENTOR.  
*A. E. Brown*  
*J. E. H. Bates* Attorney

# UNITED STATES PATENT OFFICE.

ALEXANDER E. BROWN, OF SOMERVILLE, MASSACHUSETTS.

## FURNITURE-CASTER.

SPECIFICATION forming part of Letters Patent No. 455,906, dated July 14, 1891.

Application filed April 13, 1891. Serial No. 388,636. (No model.)

*To all whom it may concern:*

Be it known that I, ALEXANDER E. BROWN, a citizen of the United States, residing at Somerville, in the county of Middlesex and State of Massachusetts, have invented certain new and useful Improvements in Furniture-Casters; and I do hereby declare the following to be a full, clear, and exact description of the invention, such as will enable others skilled in the art to which it appertains to make and use the same.

This invention has relation to improvements in furniture-casters; and it consists in the construction, novel arrangement, and combination of parts of which it is composed, all as will be hereinafter fully described.

The annexed drawings, to which reference is made, fully illustrate my device, in which—

Figure 1 represents a side view of my improved caster. Fig. 2 is a vertical sectional view of the same. Fig. 3 is a horizontal sectional view taken on line *xx*, Fig. 2; and Fig. 4 is also a horizontal sectional view of the same, taken on line *yy*, Fig. 2, of the drawings.

Referring by letter to the accompanying drawings, *A* designates the caster, the main portion of which is in three sections *a*, *b*, and *c*. The upper section *a* has an integral extension *d*, which is hollow to receive the foot of an article of furniture and forming a socket therefor. The interior of this caster is hollow, and the space is divided from that of the socket by a horizontal wall or partition *e*, and the lower portion of the section *a* has a flange *f*, which engages a flange *g* on the section *b*, thus providing means whereby these two sections can be readily taken apart when it is desired to have access to the interior of said caster. Within this top section *a* is jour-

naled three wheels *h h h*, that bear upon a ball *i*, arranged within the section *b* and directly beneath said wheels. This ball fits snugly within the space *j* and in turn rests upon and is supported by a larger ball *k*, arranged within the lower space *l* of the section *b*. This lower portion of the caster is provided with three wheels *m m m*, that are journaled between the lower section *c* and the section *b*. Said wheels have their bearing upon the lower ball aforesaid, thus providing a roller-bearing both at the sides and top. The lower section *c* is secured to the section *b* by screws and can be easily detached at will.

It will be seen by reference to the annexed drawings that the weight is borne by the top wheels and pair of balls, and the device can be applied to any article of furniture, pianos, safes, desks, &c., and it is simple in construction, durable, and at the same time cheap to manufacture.

I am aware of English patent numbered 642 of 1856, for furniture-casters; hence I do not claim, broadly, such a device; but

What I claim, and desire to secure by Letters Patent, is—

In a furniture-caster, the combination, with the main sectional portion, the wheels *h h*, journaled within the section *a*, the ball *i*, engaging said wheels, and the ball *k*, engaging both the ball *i* and lateral wheels *m m*, journaled in the lower section, all as shown and described.

In testimony whereof I affix my signature in presence of two witnesses.

ALEXANDER E. BROWN.

Witnesses:

JOHN E. WISDOM,  
LOUIS SEGOL.