

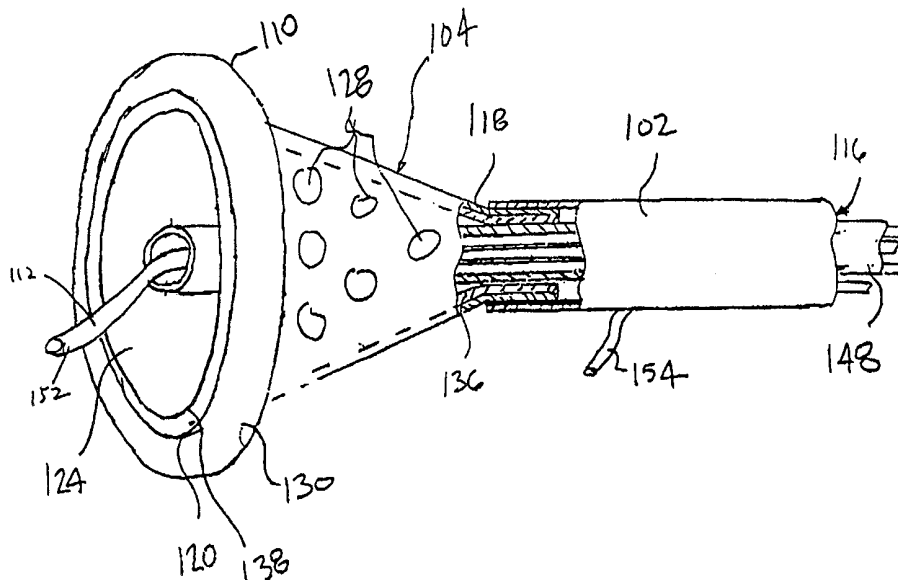

INTERNATIONAL APPLICATION PUBLISHED UNDER THE PATENT COOPERATION TREATY (PCT)

(51) International Patent Classification ⁷ : A61M 31/00	A1	(11) International Publication Number: WO 00/51675 (43) International Publication Date: 8 September 2000 (08.09.00)
<p>(21) International Application Number: PCT/US00/05005</p> <p>(22) International Filing Date: 25 February 2000 (25.02.00)</p> <p>(30) Priority Data: 09/260,371 1 March 1999 (01.03.99) US</p> <p>(71) Applicant: COAXIA, INC. [US/US]; 70 East 77th Street, New York, NY 10021-1181 (US).</p> <p>(72) Inventor: BARBUT, Denise; 70 East 77th Street, New York, NY 10021 (US).</p> <p>(74) Agent: KAPPOS, John, C.; Lyon & Lyon LLP, 633 West Fifth Street, Suite 4700, Los Angeles, CA 90071-2066 (US).</p>		<p>(81) Designated States: CA, JP, European patent (AT, BE, CH, CY, DE, DK, ES, FI, FR, GB, GR, IE, IT, LU, MC, NL, PT, SE).</p> <p>Published <i>With international search report.</i></p>

(54) Title: PARTIAL AORTIC OCCLUSION DEVICES AND METHODS FOR CEREBRAL PERFUSION AUGMENTATION



(57) Abstract

Methods are provided for partial aortic occlusion for cerebral perfusion augmentation in patients suffering from global or focal cerebral ischemia. Alternatively, the methods can be used to partially occlude aortic blood flow to condition the spinal cord to secrete neuro-protective agents prior to abdominal aortic aneurysm repair. Partial occlusion of a vessel can be accomplished by a device comprising an elongate catheter (102), a distally mounted expandable occludent (104), a variable flow mechanism, and a manometer (112). The occludent (104) may comprise two conical shells (118, 136) or an inflatable ring-shaped balloon (130) disposed about a cylindrical sleeve. Other medical devices, such as an atherectomy catheter, can be inserted distal the occludent to provide therapeutic intervention.

FOR THE PURPOSES OF INFORMATION ONLY

Codes used to identify States party to the PCT on the front pages of pamphlets publishing international applications under the PCT.

AL	Albania	ES	Spain	LS	Lesotho	SI	Slovenia
AM	Armenia	FI	Finland	LT	Lithuania	SK	Slovakia
AT	Austria	FR	France	LU	Luxembourg	SN	Senegal
AU	Australia	GA	Gabon	LV	Latvia	SZ	Swaziland
AZ	Azerbaijan	GB	United Kingdom	MC	Monaco	TD	Chad
BA	Bosnia and Herzegovina	GE	Georgia	MD	Republic of Moldova	TG	Togo
BB	Barbados	GH	Ghana	MG	Madagascar	TJ	Tajikistan
BE	Belgium	GN	Guinea	MK	The former Yugoslav Republic of Macedonia	TM	Turkmenistan
BF	Burkina Faso	GR	Greece	ML	Mali	TR	Turkey
BG	Bulgaria	HU	Hungary	MN	Mongolia	TT	Trinidad and Tobago
BJ	Benin	IE	Ireland	MR	Mauritania	UA	Ukraine
BR	Brazil	IL	Israel	MW	Malawi	UG	Uganda
BY	Belarus	IS	Iceland	MX	Mexico	US	United States of America
CA	Canada	IT	Italy	NE	Niger	UZ	Uzbekistan
CF	Central African Republic	JP	Japan	NL	Netherlands	VN	Viet Nam
CG	Congo	KE	Kenya	NO	Norway	YU	Yugoslavia
CH	Switzerland	KG	Kyrgyzstan	NZ	New Zealand	ZW	Zimbabwe
CI	Côte d'Ivoire	KP	Democratic People's Republic of Korea	PL	Poland		
CM	Cameroon	KR	Republic of Korea	PT	Portugal		
CN	China	KZ	Kazakstan	RO	Romania		
CU	Cuba	LC	Saint Lucia	RU	Russian Federation		
CZ	Czech Republic	LI	Liechtenstein	SD	Sudan		
DE	Germany	LK	Sri Lanka	SE	Sweden		
DK	Denmark	LR	Liberia	SG	Singapore		
EE	Estonia						

DESCRIPTION

Partial Aortic Occlusion Devices And Methods For Cerebral Perfusion Augmentation

Field of the Invention

5 The present invention relates generally to medical devices. More particularly, the invention relates to methods and devices for augmenting blood flow to a patient's vasculature. More particularly, the invention relates to apparatus and methods which provide partial obstruction ("coarctation") to aortic blood flow to augment cerebral perfusion in patients with global or focal ischemia. The devices and methods also provide mechanisms for continuous constriction and variable blood flow through the
10 aorta.

Background of the Invention

Patients experiencing cerebral ischemia often suffer from disabilities ranging from transient neurological deficit to irreversible damage (stroke) or death. Cerebral ischemia, *i.e.*, reduction or cessation of blood flow to the central nervous system, can be
15 characterized as either global or focal. Global cerebral ischemia refers to reduction of blood flow within the cerebral vasculature resulting from systemic circulatory failure caused by, *e.g.*, shock, cardiac failure, or cardiac arrest. Shock is the state in which failure of the circulatory system to maintain adequate cellular perfusion results in reduction of oxygen and nutrients to tissues. Within minutes of circulatory failure,
20 tissues become ischemic, particularly in the heart and brain.

The two common forms of shock are cardiogenic shock, which results from severe depression of cardiac performance, and hemorrhagic shock, which results from trauma. The most frequent cause of cardiogenic shock is myocardial infarction with loss of substantial muscle mass. Pump failure can also result from acute myocarditis or from
25 depression of myocardial contractility following cardiac arrest or prolonged cardiopulmonary bypass. Mechanical abnormalities, such as severe valvular stenosis, massive aortic or mitral regurgitation, acutely acquired ventricular septal defects, can also cause cardiogenic shock by reducing cardiac output. Additional causes of cardiogenic shock include cardiac arrhythmia, such as ventricular fibrillation.
30 Hemorrhagic shock is typically the result of penetrating injuries such as those caused by traffic accidents and gunshot wounds. In this case, cardiac function is unimpaired and the cause of shock is blood loss.

Treatment of global cerebral ischemia involves treating the source of the systemic

circulatory failure and ensuring adequate perfusion to the central nervous system. For example, treatment of cardiogenic shock due to prolonged cardiopulmonary bypass consists of cardiovascular support with the combination of inotropic agents such as dopamine, dobutamine, and intra-aortic balloon counterpulsation. Treatment of
5 hemorrhagic shock consists of volume replacement and hemostasis. When these measures fail, supraceliac aortic clamping is used. Vasoconstrictors, such as norepinephrine, are also administered systemically to maintain systolic blood pressure (ideally above 80 mmHg). Unfortunately, these agents produce a pressure at the expense of flow, particularly blood flow to small vessels such as the renal arteries. The use of the
10 vasoconstrictors is, therefore, associated with significant side effects, such as acute renal failure.

Focal cerebral ischemia refers to cessation or reduction of blood flow within the cerebral vasculature resulting from a partial or complete occlusion in the intracranial or extracranial cerebral arteries. Such occlusion typically results in stroke, a syndrome
15 characterized by the acute onset of a neurological deficit that persists for at least 24 hours, reflecting focal involvement of the central nervous system and is the result of a disturbance of the cerebral circulation. Other causes of focal cerebral ischemia include vasospasm due to subarachnoid hemorrhage or iatrogenic intervention.

Traditionally, emergent management of acute ischemic stroke consists of mainly
20 general supportive care, *e.g.*, hydration, monitoring neurological status, blood pressure control, and/or anti-platelet or anti-coagulation therapy. Heparin has been administered to stroke patients with limited and inconsistent effectiveness. In some circumstances, the ischemia resolves itself over a period of time due to the fact that some thrombi get absorbed into the circulation, or fragment and travel distally over a period of a few days.
25 In June 1996, the Food and Drug Administration approved the use of tissue plasminogen activator (t-PA) or *Activase*®, for treating acute stroke. However, treatment with systemic t-PA is associated with increased risk of intracerebral hemorrhage and other hemorrhagic complications. Aside from the administration of thrombolytic agents and heparin, there are no therapeutic options currently on the market for patients suffering
30 from occlusive focal cerebral ischemia. Vasospasm may be partially responsive to vasodilating agents. The newly developing field of neurovascular surgery, which involves placing minimally invasive devices within the carotid arteries to physically remove the offending lesion may provide a therapeutic option for these patients in the future, although this kind of manipulation may lead to vasospasm itself. Iatrogenic
35 vasospasm and vasospasm caused by subarachnoid hemorrhage may respond to treatment with aortic constriction.

In both global and focal ischemia, patients develop neurologic deficits due to the reduction in cerebral blood flow. Treatments should include measures to increase blood flow to the cerebral vasculature to maintain viability of neural tissue, thereby increasing the length of time available for interventional treatment and minimizing neurologic deficit while waiting for resolution of the ischemia. Augmenting blood flow to the cerebral vasculature is not only useful in treating occlusive or vasospastic cerebral ischemia, but may also be useful during interventional procedures, such as carotid angioplasty, stenting or endarterectomy, which might otherwise result in focal cerebral ischemia, and also cardiac procedures which may result in cerebral ischemia, such as cardiac catheterization, electrophysiologic studies, and angioplasty.

New devices and methods are thus needed for augmentation of cerebral blood flow in treating patients with either global or focal ischemia caused by reduced perfusion, thereby minimizing neurologic deficits.

Summary of the Invention

The invention provides vascular constriction devices and methods for augmenting blood flow to a patient's cerebral vasculature, including the carotid and vertebral arteries. The devices constructed according to the present invention comprise a constricting mechanism distally mounted on a catheter for delivery to a vessel, such as the aorta. The constrictor is collapsed to facilitate insertion into and removal from the vessel, and expanded during use to restrict blood flow. When expanded, the constrictor has a maximum periphery that conforms to the inner wall of the vessel, thereby providing a sealed contact between it and the vessel wall. The constrictor typically has a blood conduit allowing blood flow from a location upstream to a location downstream. The devices further include a variable flow mechanism in operative association with the blood conduit, thereby allowing blood flow through the conduit to be adjusted and controlled. The devices can optionally include a manometer and/or pressure limiter to provide feedback to the variable flow mechanism for precise control of the upstream and downstream blood pressure. In certain embodiments, the constrictor includes a second lumen for passage of other medical devices. Devices, such as an infusion, atherectomy, angioplasty, hypothermia catheters or devices (selective cerebral hypothermia with or without systemic hypothermia, and typically hypothermia will be combined with measures to increase perfusion to overcome the decreased cerebral blood flow caused by the hypothermia, such that hypothermia and coarctation are complimentary), or electrophysiologic study (EPS) catheter, can be introduced through the constrictor to insert in the vessel to provide therapeutic interventions at any site rostrally.

In a preferred embodiment, the expandable constrictor comprises an outer conical shell and an inner conical shell. Each shell has an apex and an open base to receive blood flow. One or a plurality of ports traverses the walls of the two conical shells. Blood flows through the open base and through the ports. The inner shell can be rotated relative to the outer shell so that the ports align or misalign with the ports in the outer shell to allow variable blood flow past the occluder, thereby providing adjustable and controlled flow. The inner shell is rotated by a rotating mechanism, *e.g.*, a torque cable disposed within the elongate tube and coupled to the inner shell. The constrictor can be expanded by, *e.g.*, a resilient pre-shaped ring, graduated rings, or a beveled lip formed at the base of the shell, and collapsed by, *e.g.*, pull wires distally affixed to the occluder or a guide sheath.

In another embodiment, the outer conical shell includes a plurality of resilient flaps, which are pivotally affixed to the base or the apex and can be displaced to variably control blood flow through the conduit. The flaps can be displaced by a plurality of pull wires affixed to the flaps.

In still another embodiment, the constrictor comprises a first cylindrical balloon mounted to a distal end of the catheter, and a second toroidal balloon disposed about the cylindrical balloon. The chamber of the first balloon communicates with an inflation lumen. Blood flow occurs through the cylindrical balloon and through the center of the toroidal balloon. The toroidal balloon is expanded by inflation through a second and independent inflation lumen to reduce blood flow through the cylindrical balloon. In this manner, the first balloon provides an inflatable sleeve and the second toroidal balloon provides variable control of blood flow through the sleeve. Other embodiments include an expandable sleeve (not a balloon) surrounded by a toroidal balloon, or a spring mechanism, for adjustably constricting the flow of blood through the cylindrical sleeve.

In a preferred method, the constriction devices described above are inserted into the descending aorta through an incision on a peripheral artery, such as the femoral, subclavian, axillary or radial artery, in a patient suffering from global or focal cerebral ischemia, typically stroke, shock or vasospasm, or during cardiac surgery (including any operation on the heart, with or without CPB), or during aortic surgery (during circulatory arrest, as for aortic arch surgery, repair of an abdominal aortic aneurysm, or thoracic aneurysm repair, to reduce perfusion and the amount of blood loss in the operating field). The devices can be introduced over a guide wire. With assistance of transesophageal echocardiography (TEE), transthoracic echocardiography (TTE), intravascular ultrasound (IVUS), aortic arch cutaneous ultrasound, or angiogram, the constrictor is positioned downstream from the takeoff of the brachiocephalic artery and upstream from

the renal arteries. When the constrictor is inserted in its preferred position, *i.e.*, below the renal arteries, no visualization is necessary with any imaging equipment. The constrictor is expanded to partially occlude blood flow in the aorta and maintained during systole, during diastole, or during systole and diastole. The constrictor preferably achieves continuous apposition to the wall of the vessel, resulting in fewer emboli dislodgment. The pressure limiter, connected to the rotary unit and the pressure monitor, prevents the upstream and downstream blood pressure from exceeding, respectively, a set maximum and minimum pressure differential.

Flow rates can be varied within one cardiac cycle (*e.g.*, 80% during systole, 20% during diastole, or 70% during systole, 30% during diastole), and every few cycles or seconds (*e.g.*, 80% for 6 cycles, 20% for 2 cycles, or 70% for 5 cycles, 10% for 1 cycle). In certain cases it may be preferred to cycle between lesser and greater occlusion so that the brain does not autoregulate. This ensures constant and continued increased cerebral perfusion. In this manner, blood in the descending aorta is diverted to the cerebral vasculature, thereby increasing cerebral perfusion and minimizing neurological deficits. By selectively increasing cerebral blood flow, the use of systemically administered vasoconstrictors or inotropic agents to treat shock may be reduced or eliminated.

In another method, in patients anticipating a major cardiothoracic surgery, such as abdominal aortic aneurysm repair, the device is introduced and deployed approximately 24 hours prior to surgery, thereby inducing mild artificial spinal ischemia. This induces endogenous neuroprotective agents to be released by the spinal cord and/or brain in response to the ischemia, thereby protecting the tissue from ischemic insult of surgery. This technique is known as "conditioning." The devices are inserted into the descending aorta. To induce spinal ischemia, the constrictor is positioned downstream from the takeoff of the brachiocephalic artery and upstream from the renal artery and expanded to partially occlude blood flow in the aorta, resulting in reduction of blood flow to the spinal cord. A similar technique may be employed to condition the brain to stimulate production of neuroprotective agents. To induce cerebral ischemia, the constrictor is positioned upstream from the takeoff of the innominate artery, or between the innominate artery and the left common carotid artery.

It will be understood that there are many advantages in using the partial aortic occlusion devices and methods disclosed herein. For example, the devices can be used (1) to provide variable partial occlusion of a vessel; (2) to augment and maintain cerebral perfusion in patients suffering from global or focal ischemia; (3) to condition the brain or spinal cord to secrete neuroprotective agents prior to a major surgery which will necessitate reduced cerebral or spinal perfusion; (4) to prolong the therapeutic window in

global or focal ischemia; (5) to accommodate other medical devices, such as an atherectomy catheter; (6) prophylactically by an interventional radiologist, neuroradiologist, or cardiologist in an angiogram or fluoroscopy suite; (7) for prevention of cerebral ischemia in patients undergoing procedures, such as coronary catheterization or surgery, where cardiac output might fall as a result of arrhythmia, myocardial infarction or failure; (8) to treat shock, thereby eliminating or reducing the use of systemic vasoconstrictors; (9) to prevent hypotensive neurologic damage during carotid stenting, and (10) to rescue vasospasm induced by hemorrhage or interventional procedures.

10 Brief Description of the Drawings

Fig. 1 illustrates a patient's systemic arterial circulation relevant to the present invention.

Fig. 2 illustrates an embodiment of the devices constructed according to the present invention for providing partial occlusion of a vessel.

15 Fig. 3 illustrates a constrictor of the device depicted in Fig. 2.

Fig. 4A illustrates an outer conical shell employed in the constrictor of Fig. 3.

Fig. 4B illustrates an inner conical shell employed in the constrictor of Fig. 3.

Fig. 5 illustrates an alternative embodiment of the constrictors of Fig. 3 having elongate rectangular ports.

20 Fig. 6 illustrates another embodiment of the occluder having a beveled lip.

Fig. 7 illustrates another embodiment of the occluder having a plurality of graduated rings.

Fig. 8 illustrates complete misalignment of the ports on the outer and inner conical shells.

25 Fig. 9 illustrates partial alignment of the ports on the outer and inner conical shells.

Fig. 10 illustrates complete alignment of the ports on the outer and inner conical shells.

30 Fig. 11 illustrates another embodiment of the device for providing partial occlusion of a vessel.

Fig. 12 illustrates another embodiment of the constrictor employed in the device of Fig. 11.

Fig. 13A illustrates a frontal view of the constrictor of Fig. 12 having a plurality of preformed flaps extending perpendicular to the longitudinal axis of the constrictor.

35 Fig. 13B illustrates a frontal view of the flaps of Fig. 13A under an external

force.

Fig. 13C illustrates a frontal view of the constrictor of Fig. 12 having a plurality of preformed flaps extending parallel to the longitudinal axis of the constrictor.

5 Fig. 13D illustrates a frontal view of the flaps of Fig. 13C under an external force.

Fig. 14 illustrates another embodiment of the occluder having flaps included in the collar of the outer conical shell.

Fig. 15 illustrates still another embodiment of the device for providing partial occlusion of a vessel.

10 Fig. 16 illustrates an embodiment of the constrictor employed in the device of Fig. 15.

Fig. 17 illustrates the constrictor of Fig. 16, having an inflated ring-shaped balloon for reducing blood flow through a blood conduit.

Fig. 18 illustrates the occluder of Fig. 16, having a deflated ring-shaped balloon.

15 Fig. 19 illustrates a suction/atherectomy catheter introduced through the constrictor of Fig. 16.

Fig. 20 illustrates a perfusion and an EPS catheter introduced through the constrictor of Fig. 16.

20 Fig. 21A illustrates the constrictor of Fig. 3 inserted in the aorta downstream from the left subclavian artery and partially occluding aortic blood flow.

Fig. 21B illustrates the constrictor of Fig. 14 inserted in the aorta downstream from the left subclavian artery and partially occluding aortic blood flow.

Fig. 22 illustrates the constrictor of Fig. 3 inserted in the aorta downstream from the right brachiocephalic artery and partially occluding aortic blood flow.

25 Fig. 23 illustrates a suction/atherectomy catheter introduced through the constrictor of Fig. 3 and inserted in the left carotid artery proximal to a thromboembolic occlusion.

Fig. 24 illustrates the constrictor of Fig. 3 inserted in the aorta upstream from the lumbar or lumbar or spinal arteries.

30 Fig. 25 illustrates the constrictor of Fig. 3 inserted in the renal arteries.

Fig. 26 depicts a graph of cerebral blood flow versus time in a stroke induced rat brain.

Fig. 27 depicts a fluorescent stain of a rat brain section having normal capillary perfusion.

35 Fig. 28 depicts a fluorescent stain of the stroke center in a rat brain section after induction of stroke.

Fig. 29 depicts a fluorescent stain of the stroke penumbra in a rat brain section after induction of stroke.

Fig. 30 depicts a fluorescent stain of the stroke center in a rat brain section after placement of a coarctation device.

5 Fig. 31 depicts a fluorescent stain of the stroke penumbra in a rat brain section after placement of a coarctation device.

Fig. 32A depicts an embodiment of a constrictor that can be removably mounted on a standard catheter.

Fig. 32B depicts the inflated constrictor of Fig. 32A.

10 Fig. 32C depicts another embodiment of a constrictor that can be removably mounted on a standard catheter.

Fig. 32D depicts the inflated constrictor of Fig. 32C.

Fig. 32E depicts another embodiment of the constrictor having a manometer and lumen allowing passage of other devices.

15 Fig. 32F depicts the inflated constrictor of Fig. 32E.

Fig. 32G depicts another embodiment of the constrictor having a spring mechanism constricting its lumen.

Fig. 32H depicts the constrictor of Fig. 32G with the spring mechanism relaxed.

20 Fig. 33A depicts a constrictor mechanism mounted on a stent deployment catheter.

Fig. 33B depicts the catheter and constrictor of Fig. 33A with the constrictor expanded.

Fig. 34A depicts another embodiment of a constrictor having an introducer sheath and an inflatable balloon catheter within the sheath.

25 Fig. 34B depicts a cross-sectional view of the catheter of Fig. 34A through sectional line B-B.

Detailed Description of the Preferred Embodiments

The devices and methods disclosed herein are most useful in treating patients suffering from global cerebral ischemia due to systemic circulatory failure, and focal cerebral ischemia due to thromboembolic occlusion of the cerebral vasculature. However, it will be understood that the devices and methods can be used in other medical conditions, such as hypertension and spinal cord conditioning.

35 Systemic arterial circulation relevant to the methods of the present invention is described in Fig. 1. During systole, oxygenated blood leaving heart 8 enters aorta 10, which includes ascending aorta 12, aortic arch 14, and descending aorta 22. The aortic

arch gives rise to brachiocephalic trunk 16, left common carotid artery 18, and left subclavian artery 20. The brachiocephalic trunk branches into right common carotid artery 24 and right subclavian artery 26. The right and left subclavian arteries, respectively, give rise to right vertebral artery 28 and left vertebral artery 34. The
5 descending aorta gives rise to a multitude of arteries, including lumbar (*i.e.*, spinal) arteries 38, which perfuse the spinal cord, renal arteries 40, which perfuse the kidneys, and femoral arteries 42, which perfuse the lower extremities.

Fig. 2 depicts occlusion catheter 100 for use in the methods described herein. The device includes elongate catheter 102, distally mounted expandable constrictor, *i.e.*,
10 occluder, 104 having distal opening 124 and variable flow mechanism 108. The constrictor, when expanded, has maximum periphery 110, which conforms to the inner wall of a vessel to form a secure seal with the vascular wall, such that blood flow through the vessel can be effectively controlled. Opening 124 receives blood from distal the constrictor and controls the passage of blood proximal the constrictor. Variable flow
15 mechanism 108, connected to rotary unit 150, operates the constrictor, thereby controlling (1) the flow rate through the occlusion, and (2) upstream blood pressure. Preferably, the device includes manometer 112, which is connected to pressure monitor 156 and pressure limiter 114. Rotary unit 150 receives blood pressure measurements from the manometer. Pressure limiter 114, connected to the rotary unit and the pressure
20 monitor, prevents the upstream and downstream blood pressure from exceeding, respectively, a set maximum and minimum pressure differential. A proximal end of the catheter is equipped with adapter 103, from which pull wires 132 can be manipulated for collapsing the occluder and to which the rotary unit, pressure monitor, and/or pressure limiter can be connected.

25 Referring to Fig. 3, the occlusion device comprises catheter 102 and constrictor 104. The catheter is constructed from a biocompatible and flexible material, *e.g.*, polyurethane, polyvinyl chloride, polyethylene, nylon, etc. The catheter includes lumen 116 through which various operative elements pass. Alternatively, the catheter may include more than one lumen to support various operative elements. The catheter also
30 includes proximal adapter 103 (see Fig. 2), which provides an interface between the catheter and the various instruments received by the catheter. The occluding mechanism consists of outer conical shell 118 and inner conical shell 136, each having a distal open base and a proximal apex. Pre-shaped ring 130 is affixed to base 120 of the outer shell to facilitate expansion of the constrictor. The ring is formed of a resilient material,
35 capable of expanding the occluder to achieve a maximum periphery, which is defined by the outer circumference of the ring. Ring 130, may, in certain embodiments, further

include an anchoring mechanism, such as hooks, bonded to the outer circumference of the ring. Expansion of the ring causes the grasping structure to engage the surface of the vessel wall, thereby securing the occluder and preventing displacement in the vessel due to force exerted by blood flow. In other embodiments, the anchoring is provided by an adhesive strip, vacuum, or merely by frictional engagement of the vessel lumen by the ring.

The constrictor can be collapsed to facilitate insertion into and removal from a vessel. A plurality of pull wires 132 (Fig. 2) are disposed within torque cable 148, and are distally connected to base 120 of outer shell 118 and proximally passes through adapter 103. The constrictor is collapsed by applying a tensile force on wires 132, using torque cable 148 to provide leverage to the pull wires, thereby drawing the circumference of the open base 120 towards its center and collapsing the occluder. A guide sheath (not shown) can be alternatively used to collapse the constrictor. Using this technique, the guide sheath would cover the constrictor and be withdrawn to release the constrictor and advanced to collapse the constrictor.

Opening 124 is formed in base 138 and 120 of the respective inner and outer conical shells to provide an inlet for blood flow. Conical interior 106 communicates with ports 128 of the outer shell. When the constrictor is deployed, blood flows into opening 124, through interior 106, and exits through ports 128. The occluding mechanism comprises inner conical shell 136 (partially shown in phantom in Fig. 3), which is rotatably disposed within outer shell 118 as shown in Figs. 8, 9, and 10. The inner shell can be rotated relative to the outer shell through torque cable 148, which is disposed in lumen 116 of catheter 102.

Manometer 112 comprises upstream pressure tube 152 and downstream pressure tube 154, both connected proximally to a pressure monitor to provide respective blood pressure measurements upstream and downstream the constrictor. The upstream pressure tube extends distal to opening 124, or may be attached to the inner shell. The downstream pressure tube extends through an orifice in the catheter proximal to the constrictor. The upstream and downstream blood pressure measurements are recorded and displayed by the pressure monitor at a proximal end of the catheter. A pressure limiter, programmed with a maximum pressure threshold to limit the upstream blood pressure and a minimum pressure threshold to limit the downstream blood pressure, is connected to the pressure monitor to receive pressure measurements therefrom, and transmits information to a rotary unit. The limiter thereby prevents the rotary unit from rotating the inner shell relative to the outer shell in a manner that would cause the upstream blood pressure to exceed the maximum threshold, or the downstream blood

pressure to fall below the minimum threshold. Without the rotary unit, torque cable 148 can also be manually rotated to obtain desired upstream and downstream blood pressures. An audible alarm may be incorporated into the pressure limiter to sound when blood pressures exceeds the thresholds. The pressure limiter may further comprise an interlocking device. The interlocking device, in operative association with upstream and downstream tubes 152 and 154, can lock inner shell 136 with respect to outer shell 118 as blood pressures approach the set thresholds. It should be noted that although the rotary unit, pressure monitor, and pressure limiter are shown as separate units, they may be incorporated into an integral unit.

Referring to Figs. 4A and 4B, the expanded constrictor comprises outer conical shell 118 having base 120 and apex 122, and inner conical shell 136 having base 138 and apex 140. The constrictor is preferably composed of a biocompatible material coated with heparin to prevent blood clotting. The conical shape of the expanded constrictor minimizes turbulence caused by placement of the occluder in the vessel. The outer and inner shells include 2, 3, 4, 5, 6, or any other number of ports 128 and 144, respectively, in communication with the conical interior to permit blood flow through the occluder. The inner shell can be rotated relative to the outer shell, so that ports 144 communicate with ports 128. Apices 122 and 140 of the respective outer and inner shells further comprise collar 126 and 142. The collars may include engaging threads, so that collar 142 can be inserted and secured into collar 126, and bonded to a distal end of the torque cable, such that the inner shell is coupled to and rotates with the torque cable. A rotary unit, preferably including a stepper motor (not shown), may be mechanically coupled to a proximal end of the torque cable to provide precise rotational position of the inner shell relative to the outer shell, thereby providing variable flow through the occluder.

Instead of having the circular ports in the inner and outer shells as depicted in Figs. 4A and 4B, the constrictor may include 2, 3, 4, 5, 6, or any other number of ports having other suitable geometric shapes. Fig. 5 depicts constrictor 104 having a plurality of ports constructed as elongate rectangular slots 175.

Fig. 6 depicts another embodiment of the constrictor, which comprises beveled lip 140 having distal end 142 and proximal end 141. The proximal end is affixed to base 120 of the outer conical shell. The proximal end has a larger diameter than the distal end and is everted to prevent the constrictor from being displaced in the direction of blood flow, thereby securing the constrictor in the vessel.

Still another embodiment of the occluder may includes 1, 2, 3, 4, 5, or any other number of graduated inflatable rings. In Fig. 7, ring 151 is affixed to the base of the conical shell. Ring 153, having the smallest inflated diameter, is attached to ring 152,

which is then attached to ring 151, having the largest inflatable diameter. The fully inflated rings will have a thickness of approximately 2 to 3 millimeters. Similar to the beveled lip of Fig. 8, the rings prevent the outer conical shell from being displaced in the direction of blood flow, thereby securing the constrictor in the vessel.

5 The flow rate of blood through the constrictor can be easily controlled by rotating inner conical shell 136 (shown with dotted lines) relative to outer conical shell 118 as depicted in Figs. 8, 9, and 10. In Fig. 8, the inner shell is rotated so that ports 144 and 128 are completely misaligned, thereby achieving no flow through the ports and complete vascular occlusion distally. As the inner shell is rotated clockwise relative to
10 the second shell in Fig. 9, ports 144 on the inner shell become partially aligned with ports 128 on the outer shell, thereby achieving partial flow through the ports and partial vascular occlusion. In Fig. 10, with continuing clockwise rotation of the inner shell, ports 144 become completely aligned with ports 128, thereby achieving maximum flow through the ports. To provide a broader and more predictable range of blood flow
15 through the conduit, the ports of the inner and outer shells are preferably of equal size and number such that they may align with each other.

 Fig. 11 depicts another embodiment of the occlusion device for partial occlusion of blood flow in a vessel. Device 200 comprises elongate catheter 202, distally mounted expandable constrictor 204 with maximum periphery 210, opening 224, and variable
20 flow mechanism 208 operatively associated with the constrictor. The catheter includes adapter 203 at its proximal end. Preferably, the device includes manometer 212 and pressure limiter 214, and pressure monitor 240. The pressure monitor records and displays blood pressure data received from the manometer. Longitudinal positioning unit 208, receiving signals from pressure limiter 214, and controls variable flow
25 mechanism 208 to provide variable blood flow through the constrictor.

 Referring to Fig. 12, catheter 202 includes lumen 216. Constrictor 204 comprises hollow conical shell 218 having base 220 and apex 222. The inner circumference of the base forms opening 224, which provides a distal inlet for blood flow through the constrictor. The inner circumference of apex 222 forms collar 228 with proximal
30 opening 226, which provide an outlet for blood flow through the constrictor. The conical interior, disposed within shell 218, communicates with opening 224 distally and opening 226 proximally. When the base of the constrictor is positioned upstream in a vessel, blood flows into opening 224, through the conical interior, and exits downstream through opening 226. The catheter is bonded to collar 228 about a portion of its inner
35 circumference. The constrictor is expanded by operation of ring 230, a beveled lip, or a series of graduated toroidal balloons as described above. The constrictor is collapsed

and may be delivered to a vessel location by using a guide sheath.

The manometer comprises upstream pressure tube 236 and downstream pressure tube 238, which are disposed in lumen 216 of the catheter and connected proximally to a pressure monitor. The upstream pressure tube extends distal from the constrictor or may
5 be bonded to the inner surface of the conical shell, thereby providing upstream blood pressure measurement. The downstream pressure tube extends through an orifice in the catheter proximal to the constrictor, thereby providing downstream blood pressure measurement.

The variable flow mechanism comprises a plurality of flaps 230 pivotally affixed
10 to base 220. The flaps are preferably made of a resilient material, such as Nitinol, to resist movement caused by blood flow through the conduit. A plurality of pull wires 232, disposed through lumen 216, are distally connected to flaps 230, such that applying a tensile force to the wires pivotally displaces flaps 230 from their preformed position. Three of the flaps (shown in dotted lines) are displaced inward. Releasing the wires
15 allows the resilient flaps to relax and return to their preformed position. The pull wires are coupled proximally to the longitudinal positioning unit, which provides precise displacement of the flaps relative to opening 224. Alternatively, wires 232 can be manually tensed to operate the flaps. The pressure limiter receives pressure measurements from the pressure monitor and transmits signals to the longitudinal
20 positioning unit to prevent the upstream and downstream blood pressures from exceeding the set thresholds.

Figs. 13A, 13B, 13C, and 13D depict frontal views of the constrictor having flaps in various positions for controlling blood flow. In Fig. 13A, preformed flaps 230 extend radially inward toward the longitudinal axis of the catheter, as in the absence of a
25 displacing force, *i.e.*, an external force other than that created by blood flow. When the constrictor is positioned in the descending aorta, for example, the size of opening 224 and blood flow through the opening is minimized, thereby providing maximal aortic occlusion. In the presence of a displacing force, such as pulling the wires to displace flaps 230 from their preformed position as depicted in Fig. 13B, the size of aperture 224 and blood flow through the conduit increases, thereby providing partial aortic occlusion.
30

Alternatively, preformed flaps 230 extend parallel to the longitudinal axis of opening 224 in the absence of a displacing force as depicted in Fig. 13C. The size of opening 224 and blood flow through the conduit are maximized, thereby providing minimal blood flow occlusion. In the presence of a displacing force, flaps 230 are
35 pivotally displaced from their preformed position as depicted in Fig. 13D. The size of opening 224 and blood flow through the opening are minimized, thereby providing

maximal blood flow occlusion. Thus, by pivotally displacing flaps 230 relative to opening 224, the size of the opening and flow rate through the constrictor is controlled to provide variable vessel occlusion.

The constrictor shown in Fig. 12 can be alternatively mounted on catheter 202, such that base 220 is proximal to apex 222 as shown in Fig. 14A. In this embodiment, flaps 230 are formed on open apex 222. When constrictor 204 is inserted downstream in the aorta, for example, pressure tube 238 extends distally from opening 226 to provide downstream blood pressure measurements, whereas pressure tube 236 extends proximally through an orifice in the catheter to provide upstream blood pressure measurements.

In Fig. 15, another embodiment of the device comprises catheter 302, a distally mounted occluder 304 with maximum periphery 310, blood passage 306 disposed within the constrictor, and variable flow mechanism 308 in operative association with the blood conduit. Inflation device 334 communicates with the constrictor, and inflation device 338 communicates with the variable flow mechanism. The device preferably includes proximal adapter 303, manometer 312, and pressure limiter 314. Pressure monitor 312 records and displays blood pressure data from the manometer. The pressure limiter is connected to the pressure monitor and to an interlocking valve on inflation device 338, such that the blood pressure upstream and downstream the constrictor can be controlled to prevent from exceeding set thresholds.

Referring to Fig. 16, constrictor 304 is mounted to a distal end of catheter 302 having lumen 316. The constrictor comprises a sleeve or cylindrical balloon 318 having outer wall 320 and inner wall 322, which enclose chamber 323. The cylindrical balloon has first end 324 with opening 328 and second end 326 with opening 330. Catheter 302 is bonded to inner wall 322 of the cylindrical balloon. Inflation tube 332, housed within lumen 316 of the catheter, communicates distally with the cylindrical balloon and proximally with a syringe or other inflation device. The cylindrical balloon can be expanded or collapsed by injecting or removing air, saline, or other medium. Occlusion is provided by toroidal balloon 334 disposed about the outer or inner surface of sleeve 318 and communicating with inflation tube 336 and a syringe. The inflation device may include an interlocking valve to prevent unintended deflation.

Lumen 306 communicates with opening 328 distally and opening 328 proximally. When deployed in a vessel, blood flows through lumen 306 and exits downstream opening 330. The constrictor may further include an anchoring structure, shown in Fig. 16 as rings 333, which are disposed about outer wall 320 of the cylindrical sleeve and define maximum periphery 310 of the occluder.

Manometer 312 comprises upstream pressure tube 340 and downstream pressure tube 342, which are operatively connected proximally to a pressure monitor. Pressure tube 340 is bonded to the lumen of the cylindrical balloon and extends distal to provide upstream blood pressure measurements, while tube 342 emerges from the catheter proximal the occluder to provide downstream blood pressure measurements.

In Fig. 17, fluid is injected to expand balloon 334, thereby constricting sleeve 318. As a result, blood flow is constricted. In Fig. 18, balloon deflation allows sleeve 318 to revert back to its pre-shaped geometry, increasing blood flow therethrough. Thus, balloon 334 can be inflated and deflated to vary the cross-sectional diameter of lumen 306 to vary flow rate.

The occlusion devices described herein can be employed with a variety of therapeutic catheters to treat vascular abnormalities. For example, as depicted in Fig. 19, suction/atherectomy catheter 402 can be inserted through lumen 306, such that the suction/atherectomy catheter is independently movable relative to occlusive device 300. Catheter 402 includes elongate tube 404 and distally located aspiration port 406, cutting device 408, and balloon 410 for removing thromboembolic material in a vessel.

In Fig. 20, infusion catheter 502 and EPS catheter 504 are inserted through opening 206 of occlusion device 200, such that catheter 502 and 504 are independently movable relative to occlusion device 200. The infusion catheter, which includes elongate tube 506, distally located perfusion port 508, and expandable balloon 510, can be used to remove thromboembolic material in a vessel. EPS catheter 504, which includes elongate tube 512 and distally located ablation device 514, may be used to map out or ablate an extra conduction pathway in the myocardial tissue, *e.g.*, in patients suffering from Wolff-Parkinson-White syndrome. The occlusion device, capable of augmenting cerebral perfusion, is therefore useful not only in facilitating definitive treatment but also in cerebral ischemia prevention during EPS and other cardiac interventions or cardiac surgery, such as coronary catheterization, where sudden fall in cerebral blood flow may occur due to arrhythmia, myocardial infarction, or congestive heart failure.

Referring to Fig. 21A, occlusion device 100 described above can be used to partially occlude blood flow in aorta 10 of a patient suffering from global cerebral ischemia due to, *e.g.*, septic shock, congestive heart failure, or cardiac arrest. Constrictor 104 can be introduced in its collapsed geometry through an incision on a peripheral artery, such as the femoral, subclavian, axillary, or radial artery, into the patient's aorta. A guide wire may first be introduced over a needle, and the collapsed constrictor is then passed over the guide wire and the needle to position distal to the takeoff of left

subclavian artery 20 in the descending aorta. The constrictor is expanded, such that maximum periphery 110 of the occluder, formed by expandable ring 130, sealingly contacts the inner aortic wall. The position and orientation of the collapsed or expanded device can be checked by TEE, TTE, aortic arch cutaneous ultrasound in the emergency room, or IVUS and angiography in the angiogram suite.

The expanded constrictor is maintained during systole, during diastole, or during systole and diastole, during which blood distal to the brachiocephalic artery is forced to pass through opening 106, thereby providing a continuous partial occlusion of aortic blood flow. Alternatively, partial occlusion of aortic blood flow can be intermittent. As a result, blood flow to the descending aorta is partially diverted to brachiocephalic artery 16, left subclavian artery 20, and left carotid artery 18, thereby augmenting blood flow to the cerebral vasculature. In treating global ischemia, such as in shock, cerebral perfusion is increased by increasing blood flow through both carotid and vertebral arteries. Additionally, blood flow to the aorta is partially diverted to the coronary arteries by using the occlusion device, thereby augmenting flow to the coronary arteries. Using the partial occlusion methods during systemic circulatory failure may, therefore, improve cardiac performance and organ perfusion. By selectively increasing cerebral and coronary blood flow in this manner, the dosage of commonly used systemic vasoconstrictors, such as dopamine and norepinephrine, may be reduced or eliminated.

Alternatively, the device of Fig. 14, much like the device used to extinguish the flame of a candle, can be introduced through an incision on left subclavian artery 36 as depicted in Fig. 21B. Constrictor 204 is inserted in aorta 22 distal to the takeoff of the left subclavian artery to provide partial, variable, and/or continuous aortic occlusion and is advanced antegrade into the descending aorta. This device is particularly useful in situations where peripheral incision can not be made on the femoral arteries due to arteriosclerosis, thrombosis, aneurysm, or stenosis.

The devices and methods described in Figs. 21A and 21B are useful in treating stroke patients within few minutes of stroke symptom, and the treatment can be continued up to 96 hours or more. For example, in treating focal ischemia due to a thromboembolic occlusion in the right internal carotid artery the constrictor may be position distal to the takeoff of the left subclavian. As a result, blood flow is diverted to brachiocephalic artery 16 and left CCA to augment both ipsilateral and contralateral collateral circulation by reversing direction of flow across the Circle of Willis, *i.e.*, increasing flow in the right external carotid artery and left common carotid artery. The collateral cerebral circulation is further described in details in co-pending U.S. Application Serial No. 09/228,718, filed January 12, 1999, incorporated herein by

reference.

In treating focal ischemia due to a thromboembolic occlusion in the left internal carotid artery, for example, the constrictor can be positioned proximal to the takeoff of left carotid artery 18 and distal to the takeoff of brachiocephalic artery 16 as shown in
5 Fig. 22. Contralateral collateral enhancement is provided by increasing flow through the brachiocephalic artery, thereby reversing blood flow in the right posterior communicating artery, right PCA, left posterior communicating artery 68 and anterior communicating artery, resulting in increased perfusion to the ischemic area distal to the occlusion and minimizing neurological deficits. Alternatively, the constrictor may be
10 positioned distal to the takeoff of the left subclavian artery to provide both ipsilateral and contralateral collateral augmentation. Ipsilateral circulation is enhanced by increasing flow through the left external carotid artery and reversing flow along the left ophthalmic artery, both of which contribute to increased flow in the left ICA distal to the occlusion.

As a result of partially occluding aortic blood flow, blood pressure distal to the
15 aortic occlusion may decrease, and this may result in a reduction in renal output. Blood pressure proximal the aortic occlusion will increase and may result in excessive rostral hypertension. The blood pressures, measured by the manometer, are monitored continuously, and based on this information the occlusion is adjusted to avoid peripheral organ damage. After resolution of the cerebral ischemia, the constrictor is collapsed and
20 removed, thereby removing the aortic occlusion and restoring normal blood flow in the aorta.

In Fig. 23, constrictor 304 is inserted in aorta 10 and can be used to remove thromboembolic material 72 from left common carotid artery 18, while augmenting and maintaining cerebral perfusion distal to the occluding lesion. The occluder may be
25 introduced through a guide sheath until it is positioned distal to left subclavian artery 20. In emergency situations, the constrictor can be inserted through a femoral incision in the emergency room, and atherectomy/suction catheter 402 can be inserted through the constrictor under angioscopic vision in the angiogram suite after the patient is stabilized hemodynamically. The atherectomy/suction catheter, which includes expandable balloon
30 410, distal aspiration port 406, and atherectomy device 408, is introduced through opening 306 until its distal end is positioned in left common carotid artery 18 proximal to the thromboembolic occlusion.

Constrictor 304 is then expanded to partially occlude aortic blood flow, thereby increasing perfusion to the ischemic region distal to the occluding lesion by enhancing
35 ipsilateral collateral flow through left external carotid artery 46 and left vertebral artery 34 and contralateral collateral flow to right carotid artery 24 and right vertebral artery 28.

The variable flow mechanism of constrictor 304 can be adjusted to control blood flow to the cerebral vasculature and the blood pressure. Balloon 410 of catheter 402 is expanded in the left common carotid artery, thereby creating a closed chamber between constrictor 410 and the thromboembolic occlusion. Suction can be applied to aspiration port 406 to
5 create a negative pressure in the closed chamber, thereby increasing the pressure differential across the thromboembolic occlusion, which may dislodge the occluding lesion onto the aspiration port and remove the occluding lesion. Thromboembolic material 72 may be further removed by atherectomy device 408. The methods herein can also be used to remove thromboembolic occlusion in the vertebral artery. The occlusion
10 device 304, therefore, not only augments cerebral perfusion in patients suffering from focal stroke or global ischemia, but also maintains cerebral perfusion while waiting for invasive or noninvasive intervention. The devices and methods of using atherectomy/suction catheter 102 are further described in copending U.S. Application Serial No. 09/228,718, filed January 12, 1999, incorporated herein by reference.

15 During abdominal aortic aneurysm (AAA) surgery, lumbar or spinal arteries, which provide blood supply to the spinal cord, are often dissected away from the diseased abdominal aorta, resulting in reduction of blood flow to the spinal cord. The devices herein disclosed may be used to condition the spinal cord prior to AAA repair, thereby reducing the damage resulting from spinal ischemia during surgery. In Fig. 24,
20 constrictor 104 is inserted in aorta 10 and expanded preferably distal to left subclavian artery 20 and proximal to lumbar arteries 38. As a result, blood flow to the lumbar or spinal arteries is reduced. When this device is used in patients anticipating a major thoracoabdominal surgery, such as AAA repair, approximately 24 hours prior to surgery, blood flow to the lumbar arteries can be intentionally reduced to induce mild spinal
25 ischemia, thereby conditioning the spinal cord to produce neuroprotective agents which may protect the spinal cord from more significant ischemic insult during surgery.

In hypertension, end organ damage often results, *e.g.*, cardiac, renal, and cerebral ischemia and infarction. The devices and methods herein may be employed in hypertension to protect the kidneys from ischemic insult. In Fig. 25, constrictors 104,
30 which can be introduced through a femoral artery, are inserted in right renal artery 80 and left renal artery 82. The constrictors are expanded to partially occlude blood flow from descending aorta 10 to the renal arteries, thereby reducing blood pressure distal to the occlusion. The constrictors can be deployed for the duration of any systemic hypertensive condition, thereby protecting the kidneys from damage that might otherwise
35 be caused by the hypertension.

In another embodiment, the constrictor will be provided with capabilities for

mounting on a standard catheter, *e.g.*, a standard angioplasty balloon catheter, a stent deployment catheter, an ultrasound catheter, or an atherectomy catheter. Such a device having capabilities for removable mounting on a standard catheter is depicted in Figs. 32A–32H. The constrictor shown in Fig. 32A includes elongate tubular member 601
5 having lumen 605 for passage of blood extending from a proximal to a distal end of tubular member 601. The device includes constrictor 602, here a balloon mounted on tubular member 601 and communicating with inflation lumen 603. Inflation lumen 603 extends proximal, and extends through the incision in the patient so that it remains operable outside the patient's body. Tubular member 601 is constructed of a flexible and
10 deformable material so that inflation of balloon 602 causes a reduction in the cross-sectional diameter of lumen 605 as shown in Fig. 32B to reduce blood flow.

In use, tubular member 601 is positioned in the descending aorta and balloon 602 is inflated. the outer diameter of balloon 602 expands until it engages the lumen of the descending aorta. Further inflation of balloon 602 will cause deformation of tubular
15 member 601 to thereby reduce luminal diameter 605. In this manner, peripheral blood flow is reduced, resulting in an increase blood pressure upstream of the device. Because the device shown in Figs. 32A and 32B is mounted on a standard catheter (not shown), the standard catheter having diagnostic or therapeutic capabilities extends beyond tubular member 601 and may access any of the coronary arteries, carotid arteries, or any other
20 vessels upstream of the descending aorta.

Fig. 32C depicts an alternative mountable constrictor having a shortened tubular member 601, shortened by comparison with tubular member 601 shown in Fig. 32A. Fig. 32D shows the constrictor of Fig. 32C with balloon 602 inflated. It should be noted that inflation of balloon 602 proceeds until the outer diameter of balloon 602 engages the
25 lumen of the aorta, whereupon further inflation causes deformation of tubular member 601 inwardly to reduce the diameter of lumen 605, thereby constricting blood flow.

In another embodiment, a removably mountable constrictor is provided as depicted in Figs. 32E and 32F. Referring to Fig. 32E, balloon constrictor 602 communicates with a proximally extending inflation lumen (not shown), and balloon 602
30 includes first lumen 620 for passage of blood, second lumen 615 for passage of a standard catheter, and manometer 610. Blood flow lumen 620 is equipped with deformable walls 621, shown in Fig. 32F at three different levels of deformation. Lumen 615 is shaped to receive a standard catheter (angioplasty, stent, ultrasound, or atherectomy). Lumen 615 is also equipped with a locking mechanism, shown here as
35 first and second flexible clips 630 mounted at a position along lumen 615. In use, clips 630 are operated to clear a passage for advancement of a standard catheter through lumen

615. The clips are then released to frictionally engage the catheter and thereby ensure that the constrictor maintains a fixed position along the catheter.

In another embodiment shown in Figs. 32G and 32H, elongate tubular member 601 having lumen 605 is constructed of a flexible deformable material. Spring 635 is disposed about an intermediate portion of tubular member 601. Spring 635 is operable between a relaxed configuration (Fig. 32H) and a constricted configuration (Fig. 32G). The spring is operable by way of an actuating mechanism, such as a cinch strap.

A stand alone coarctation device as depicted in any of Figs. 32A–32H can be mounted on a standard catheter as depicted in Fig. 33A and 33B. Catheter 641 in Figs. 33A and 33B carries stent 640 at a distal end of catheter 641. In other embodiments the catheter may carry an angioplasty balloon, an atherectomy device, and/or intravascular ultrasound capabilities. Catheter 641 passes through lumen 605 of elongate tubular member 601. Catheter 641 is releasably engaged by tubular member 601 in a manner that allows open space for passage of aortic blood through lumen 605. Balloon 602 is mounted circumferentially about tubular member 601. In use, balloon 602 is inflated to engage the lumen of the aorta, and further inflation constricts the diameter of lumen 605, thereby reducing aortic blood flow. Tubular member 601 is constructed of a deformable material that allows inward flexing upon further inflation of balloon 602.

A balloon having capabilities for purging gas is depicted in Figs. 34A and 34B. Introducer sheath 650 is disposed about balloon 602 to facilitate entry into a major vessel, *e.g.*, a femoral artery. Balloon 602 communicates with first catheter 661 and second catheter 662, both having a lumen extending to outside the patient's body. Saline is injected through catheter 661 and fills balloon 662 through infusion port 663. Any gas within balloon 602 is purged through port 664 until balloon 602 is entirely filled with saline. Air passes through catheter 662 and exits the patient's body. Catheter 662 is then sealed, allowing balloon 602 to be inflated upon infusion of additional saline. Blood flow lumen 605 is surrounded by a deformable wall. Balloon expansion engages the lumen of the aorta, and further expansion reduces the diameter of blood flow lumen 605, increasing blood pressure upstream of the coarctation device. Fig. 34B shows a cross-section of the catheter taken through the balloon.

The length of the catheter will generally be between 20 to 150 centimeters, preferably approximately between 30 and 100 centimeters. The inner diameter of the catheter will generally be between 0.2 and 0.6 centimeters, preferably approximately 0.4 centimeters. The diameter of the base of the outer conical shell will generally be between 0.3 and 3.0 centimeters, preferably approximately 0.5 and 2.0 centimeters. The diameter of the inflated balloon occluder will generally be between 0.3 and 4.0

centimeters, preferably approximately 0.5 and 3.0 centimeters. The ports of the inner and outer conical shells will generally have a diameter of between 1 to 6 millimeters, preferably approximately 3 to 4 millimeters. The foregoing ranges are set forth solely for the purpose of illustrating typical device dimensions. The actual dimensions of a device constructed according to the principles of the present invention may obviously vary outside of the listed ranges without departing from those basic principles.

Example 1

In order to study the efficacy of the coarctation devices disclosed herein, an experiment was conducted using rats. The rat was placed under anaesthesia, and an incision was made over one or more of the carotid arteries. The middle cerebral artery was ligated and the CCA was clamped using a hemostat to abolish blood flow to the ipsilateral cerebral hemisphere, thereby inducing a stroke. The coarctation device was then introduced through a femoral artery of the rat and positioned in any level of the descending aorta, thereby causing immediate and sustained elevation in the systolic blood pressure (SBP), diastolic blood pressure (DBP), and mean arterial pressure (MAP) proximal to the constriction. It was found that the constrictions tend to produce doubling of MAP.

Fig. 26 shows a plot of cerebral blood flow (cc blood/100grams brain tissue/min.) versus time (minutes) in a rate stroke model. Cerebral blood flow (CBF) can be measured using Laser Doppler Flow (LDF) measurement. As shown in Fig. 26, IPSI refers to the cerebral hemisphere where the stroke was induced, CONTRA refers to the cerebral hemisphere where the stroke was not induced (*i.e.*, normal brain), and MBP refers to the mean blood pressure proximal to the aortic constriction.

At "initiation," the descending aorta was constricted by the deployed coarctation device. CBF is shown in Fig. 26 to increase immediately following aortic constriction as indicated by the rise in MBP. The rise in CBF can be seen at any level of placement of the coarctation devices in the descending aorta, *e.g.*, infrarenally or suprarenally. Infrarenal placement of the coarctation devices may be preferred since renal complications associated with occlusion of the renal blood supply is minimized, and prolonged use of the devices in stroke patients is permitted. The increased CBF tended to fall over a forty-minute time period in some animals.

The CBF in the ipsilateral hemisphere is also shown in Fig. 26 to increase immediately following coarctation. Ipsilateral CBF on coarctation increased by approximately two times. The fact that any increase is observed here is an unexpected result because this region of the brain represents the penumbra of the stroke. A five fold

increase CBF in the core of the stroke was also observed. This was highly unexpected. The increased ipsilateral CBF tends to fall in some animals over a forty-minute time period as well.

5 The CBF in the contralateral hemisphere is also shown to increase immediately following aortic constriction, as high as up to 500% of baseline value. The increased contralateral CBF also tends to fall over a forty-minute time period. The increase in perfusion was so marked that the devices described herein may only need to be inflated very minimally, and the degree of inflation varied with time.

10 After "termination," CBF is shown in Fig. 26 to fall immediately after coarctation is released as indicated by the fall in MBP. The CBF in the ipsilateral and contralateral hemispheres are also shown in Fig. 26 to fall immediately after coarctation is released.

15 It was also noted that deflation followed by re-inflation of the coarctation device reproduced the desired increase in CBF, even when the sequence was repeated several times. Thus, changes in MAP induce a hyperperfusional state best maintained by periodic re-inflation of the device (*e.g.*, twenty-minute periods of inflation with a few seconds of deflation in between as in the case for prolonged use of the coarctation device). One hour of coarctation may be sufficient in treatment of stroke, and thus repeated inflations would not be needed. Cerebral autoregulation during aortic coarctation was clearly overridden in this model. It is conceivable that autoregulatory curves are quite different when blood pressure and CBF are increased using aortic constriction as compared to those obtained using injection of epinephrine, a cerebral vasoconstrictor.

20 This example further explains the important differences between coarctation as described herein versus IABP. First, SBP increases when the aorta is constricted using coarctation much more than SBP increases for IABP. Second, IABP increases DBP but not SBP, and IABP pulls blood from the brain during systole. By contrast, coarctation increases both DBP and SBP, and therefore increases cerebral blood flow at all times. Third, mean CBF is increased for coarctation whereas mean CBF is unchanged for IABP. Coarctation effectively shifts the blood pressure curve upward at all points, 30 systole and diastole. Fourth, coarctation as described herein increases blood flow in the brain during stroke by 100% or more, 200% or more, 300% or more, 400% or more, and 500% or more. IABP by contrast, has been shown to increase CBF by no more than 30–40% and in some studies has caused a decrease in CBF by 10–12%. Fifth, the total occlusion produced with IABP is inadequate for the purpose of treating stroke, since the 35 increase in cerebral perfusion is so marked using the coarctation device that, the device may only need to be minimally constrict the aortic lumen.

Sixth, IABP provides sudden, jerky increases and decreases in blood pressures, since inflation or deflation is an all or none process. Deflation of IABP is associated with sudden, severe drops in MAP to below baseline values and a corresponding dramatic fall in CBF, thereby causing dangerous hypoperfusion. Cyclical deflations and inflations of IABP fail to provide a smooth and manipulable pressure proximally. The coarctation device disclosed herein incorporates a mechanism for a very slow deflation to avoid the “rebound” hypoperfusion.

Seventh, EKG linkage and external pumping are essential for the operation of IABP, but not required for the coarctation devices. Eighth, air embolization is a known complication of using IABP since air or gas is often used to inflate the balloon. The coarctation devices avoid air embolization by using liquid inflation or a spring mechanism. Tenth, spinal ischemia, aortic dissection, and renal ischemia are common complications associated with high aortic positioning of IABP, *e.g.*, at the level of subclavian takeoff. Insertion and positioning of IABP often requires fluoroscopy in an angiogram suite. The coarctation devices, on the other hand, can be inserted either suprarenally or infrarenally. The infrarenal positioning avoids the complications associated with IABP and allows insertion of the coarctation devices in the ER without the use of fluoroscopy. Eleventh, IABP is indicated in treatment of heart failure to boost coronary perfusion. By contrast, the coarctation devices can be used in treatment of stroke and non-cardiogenic shock to boost cerebral perfusion.

Example 2

Sections of rat brain were taken before and after deployment of the devices disclosed herein using fluorescent-labeled capillary perfusion techniques. After induction of three-vessel stroke, the rat was injected with a red dye, followed by deployment of a coarctation device, followed by injection of a fluorescent green dye that has affinity for patent capillary. The rat is then sacrificed and sections of the rat brain were taken and exposed microscopically under fluorescent light. Fig. 27 depicts a normal rat brain having numerous fluorescent staining capillaries.

In stroke induced rat model using the method described in Example 1, 10 rats were used in a control group and 10 rats in a treatment group. In the control group (stroke but no coarctation) a fluorescent green dye was injected prior to sacrificing the animal as described above. A dramatic reduction in the number of patent capillaries is evident in the stroke center as depicted in Fig. 28 and in the stroke penumbra of the ipsilateral hemisphere as depicted in Fig. 29. In the rats treated with the coarctation devices, the fluorescent dye is injected after constriction of the aorta. No cerebral

hemorrhages were noted microscopically in the stroke center or the surrounding tissue. The number of patent cerebral capillaries is clearly increased in the treated rats using the coarctation devices, evident in the stroke center as depicted in Fig. 30 and in the stroke penumbra as depicted in Fig. 31. A comparison of the stroke control using green dye, for which there were eight open blood vessels, to the group treated with coarctation, for which there were 20 open vessels, shows that coarctation opened more than 100% more capillaries. This example further demonstrates the efficacy of using the coarctation devices in improving cerebral blood flow for treatment of stroke.

10 Example 3 – Infarct Volume Reduction Using Coarctation Device

Using the TTC technique (technetium stain) to determine infarct (stroke) volume, one hour of treatment with a coarctation device inflated at the level of the kidneys, and started 90 minutes after the onset of stroke (induced by CCA and MCA occlusion plus occlusion of contralateral carotid artery plus occlude CCA on good side for one hour), reduced stroke volume at 24 hours from 1100 to 400. Thus, one hour of treatment achieved a 66% reduction in stroke volume. In certain animals, up to 80% reduction in stroke volume was achieved, and the stroke was not visible at low magnification. Thus, the devices and methods disclosed herein provide for a reduction in stroke volume of at least 60%, more preferably at least 70%, more preferably at least 80%, and most preferably greater than 80%.

Although the foregoing invention has, for the purposes of clarity and understanding, been described in some detail by way of illustration and example, it will be obvious that certain changes and modifications may be practiced which will still fall within the scope of the appended claims.

What is claimed is:

1. A method for increasing blood flow to a patient's cerebral vasculature, comprising the steps of:

5 providing a catheter having a proximal end, a distal end, an expandable constrictor mounted on the distal end, and a lumen extending from the proximal end and communicating with a port distal the constrictor;

inserting the distal end of the catheter into the descending aorta;

10 locating the constrictor downstream from the takeoff of the brachiocephalic artery;

expanding the constrictor to partially occlude blood flow in the aorta, wherein blood pressure in the proximal aorta increases and blood pressure in the distal aorta decreases; and

15 advancing a medical instrument through the lumen, beyond the distal port, and into an artery that branches from the aorta.

2. The method of claim 1, wherein the constrictor comprises a cylindrical member having a lumen, and wherein the step of expanding the constrictor comprises reducing the luminal diameter of the constrictor to reduce blood flow, while an outer diameter of the constrictor remains constant.

20 3. The method of claim 2, wherein the constrictor further comprises a second lumen adapted to receive a medical instrument.

25 4. The method of claim 3, wherein the constrictor further comprises a third lumen adapted to receive a manometer.

30 5. The method of claim 1, wherein the step of expanding the constrictor brings the constrictor into contact with the aorta such that the constrictor remains in contact with the wall of the aorta during use.

6. The method of claim 5, wherein the expanded constrictor includes an aperture through which blood flows during use.

7. The method of claim 5, wherein the expanded constrictor allows blood flow through gaps between the lumen of the aorta and outer dimensions of the constrictor.

5 8. The method of claim 1, wherein the catheter has a length of 3–5 cm.

9. The method of claim 1, wherein the step of expanding the constrictor includes maintaining the expanded constrictor during systole.

10 10. The method of claim 1, wherein the medical instrument is selected from the group consisting of a guiding catheter, an infusion catheter, an angioplasty catheter, a laser catheter, an angiography catheter, a therapeutic ultrasound catheter, a hypothermia catheter, a stent catheter, an imaging catheter, a perfusion catheter, an atherectomy catheter, an occlusion catheter, an EP catheter, and an aspiration catheter.

15

11. A method for increasing blood flow to a patient's cerebral vasculature, comprising the steps of:

providing a catheter having a proximal end, a distal end, and an expandable constrictor mounted on the distal end, and a lumen extending from the proximal end and communicating with a port distal the constrictor;

20 inserting the distal end of the catheter into the descending aorta;

locating the constrictor downstream from the takeoff of the brachiocephalic artery;

25 expanding the constrictor to partially occlude blood flow in the aorta, wherein blood pressure in the proximal aorta increases and blood pressure in the distal aorta decreases; and

advancing an interventional instrument through the lumen and beyond the distal port.

30 12. The method of claim 11, wherein the step of expanding the constrictor includes maintaining the expanded constrictor during systole.

35 13. The method of claim 11, wherein the interventional instrument is selected from the group consisting of an infusion catheter, an angioplasty catheter, a laser catheter, an angiography catheter, a therapeutic ultrasound catheter, a hypothermia

catheter, a stent catheter, an imaging catheter, a perfusion catheter, an atherectomy catheter, an occlusion catheter, an EP catheter, and an aspiration catheter.

- 5 14. A method for increasing blood flow to a patient's cerebral vasculature, comprising the steps of:
- providing a catheter having a proximal end, a distal end, and an expandable constrictor mounted on the distal end;
 - inserting the distal end of the catheter into the descending aorta;
 - locating the constrictor downstream from the takeoff of the
 - 10 brachiocephalic artery;
 - expanding the constrictor to partially occlude blood flow in the aorta and maintaining the expanded constrictor during systole, wherein blood pressure in the proximal aorta increases and blood pressure in the distal aorta decreases, and wherein blood flow to the cerebral vasculature increases and exaggerates the pulse wave to
 - 15 enhance the pulsatile wave form;
 - measuring a first blood pressure at a location upstream of the constrictor;
 - and
 - adjusting the constrictor based on the first measured blood pressure.

- 20 15. The method of claim 14, further comprising the step of measuring a second blood pressure at a location downstream of the constrictor, and wherein the constrictor is adjusted based on a comparison of the first and second measured blood pressures.

16. A method for increasing blood flow to a patient's cerebral vasculature, comprising the steps of:

providing a catheter having a proximal end, a distal end, and an expandable constrictor mounted on the distal end;

5 inserting the distal end of the catheter into the descending aorta;

locating the constrictor downstream from the takeoff of the brachiocephalic artery;

10 expanding the constrictor to partially occlude blood flow in the aorta, wherein blood pressure in the proximal aorta increases and blood pressure in the distal aorta decreases;

measuring a first blood pressure at a location proximal the constrictor and measuring a second blood pressure at a location distal the constrictor; and

15 adjusting the constrictor based on a comparison of the first and second measured blood pressures.

17. The method of claim 16, wherein the step of locating the constrictor downstream from the takeoff of the brachiocephalic artery comprises locating the constrictor below the renal arteries.

20 18. The method of claim 16, wherein the step of expanding the constrictor includes maintaining the expanded constrictor during systole.

19. A method for increasing blood flow to a patient's cerebral vasculature, comprising the steps of:

25 providing a catheter having a proximal end, a distal end, and an expandable constrictor mounted on the distal end;

inserting the distal end of the catheter into the descending aorta;

locating the constrictor downstream from the takeoff of the brachiocephalic artery; and

30 expanding the constrictor to partially occlude blood flow in the aorta and maintaining the expanded constrictor during systole, wherein blood pressure in the proximal aorta increases and blood pressure in the distal aorta decreases, and wherein blood flow to the cerebral vasculature increases by at least 20% and exaggerates the pulse wave to enhance the pulsatile wave form.

35

20. A method for increasing blood flow to a patient's cerebral vasculature, comprising the steps of:

- 5 providing a catheter having a proximal end, a distal end, and an expandable constrictor mounted on the distal end, wherein the constrictor is a balloon having proximal and distal ends separated by a length of no more than 20 cm;
- inserting the distal end of the catheter into the descending aorta;
- 10 locating the constrictor downstream from the takeoff of the brachiocephalic artery; and
- expanding the constrictor to partially occlude blood flow in the aorta and maintaining the expanded constrictor during systole, wherein blood pressure in the proximal aorta increases and blood pressure in the distal aorta decreases, and wherein blood flow to the cerebral vasculature increases and exaggerates the pulse wave to enhance the pulsatile wave form.

15 21. A method for increasing blood flow to a patient's cerebral vasculature, comprising the steps of:

- providing a catheter having a proximal end, a distal end, and an expandable constrictor mounted on the distal end;
- 20 inserting the distal end of the catheter into the descending aorta;
- locating the constrictor downstream from the takeoff of the brachiocephalic artery; and
- expanding the constrictor to partially occlude blood flow in the aorta and maintaining the expanded constrictor during systole, wherein blood pressure in the proximal aorta increases and blood pressure in the distal aorta decreases, and wherein
- 25 blood flow to the cerebral vasculature increases and exaggerates the pulse wave to enhance the pulsatile wave form.

22. A method for inducing production of neuroprotective agents in the spinal cord, comprising the steps of:

providing a catheter having a proximal end, a distal end, and an expandable constrictor mounted on the distal end;

5 inserting the distal end of the catheter into the descending aorta in a retrograde or antegrade direction;

locating the constrictor downstream from the takeoff of the brachiocephalic artery and upstream from the lumbar or spinal arteries; and

10 expanding the constrictor to partially occlude blood flow in the aorta, wherein blood flow to the spinal cord decreases and the spinal cord is conditioned to secrete neuroprotective agents in response to the decreased perfusion.

23. The method of claim 22, further comprising the step of performing abdominal aortic aneurysm repair on the patient.

15

24. The method of claim 22, wherein blood flow is partially occluded upstream from the lumbar or spinal arteries.

25. The method of claim 22, wherein blood flow at the partial occlusion is varied.

20

26. A method for increasing blood flow to a patient's cerebral vasculature, comprising the steps of:

25 providing a catheter having a proximal end, a distal end, and an expandable constrictor mounted on the distal end;

inserting the distal end of the catheter into the descending aorta;

locating the constrictor downstream from the takeoff of the brachiocephalic artery; and

30 expanding the constrictor to partially occlude blood flow in the aorta and maintaining the expanded constrictor during systole, wherein blood pressure in the proximal aorta increases and blood pressure in the distal aorta decreases, and wherein blood flow to the cerebral vasculature increases.

27. The method of claim 26, wherein the partial occlusion of aortic blood flow is continuous.

35

28. The method of claim 26, wherein aortic blood flow is partially occluded downstream from the takeoff of the left subclavian artery or the brachiocephalic artery.

5 29. The method of claim 26, wherein aortic blood flow is partially occluded upstream from the takeoff of the left subclavian artery.

30. The method of claim 26, wherein the patient suffers from global cerebral ischemia and blood flow to the cerebral vasculature is increased.

10 31. The method of claim 26, wherein the patient suffers from focal cerebral ischemia or vasospasm and blood flow to the cerebral vasculature is increased.

32. The method of claim 26, further comprising the step of inserting the distal end of the catheter through an incision on a peripheral artery.

15

33. The method of claim 32, wherein the peripheral artery is the femoral artery.

20 34. The method of claim 32, wherein the peripheral artery is the subclavian artery.

35. The method of claim 26, wherein blood flow through the partial occlusion is varied.

25 36. The method of claim 26, wherein at least one of the blood pressure upstream and downstream from the partial occlusion is measured, and wherein blood flow at the partial occlusion is varied based on the blood pressure measurement.

30 37. The method of claim 26, further comprising the step of removing a thromboembolic material from the carotid artery or distal cerebral vasculature.

38. The method of claim 26, further comprising the step of localizing the constrictor with transesophageal echocardiography.

39. The method of claim 26, further comprising the step of localizing the constrictor with angiogram.

40. The method of claim 26, wherein the distal end of the catheter is inserted
5 into the descending aorta in a antegrade direction.

41. The method of claim 26, wherein the constrictor is located in the aorta upstream from the renal arteries.

10 42. A medical device for partial aortic occlusion for cerebral perfusion augmentation, comprising:

an elongate member having proximal and distal ends, the distal end adapted for insertion through the femoral artery into the descending aorta;

15 an expandable constrictor mounted at the distal end of the elongate member, the constrictor expandable to engage the lumen of the aorta and having one or more adjustable passages through which distal blood flow may be carried; and

a manometer mounted distal the expandable constrictor for measuring blood pressure in the proximal aorta.

20 43. The device of claim 42, wherein the manometer includes a pressure tube extending distally from the catheter and proximally connected to a pressure monitor.

44. The device of claim 42, further comprising a pressure limiter in operative association with the manometer to receive blood pressure measurements, and a variable
25 flow mechanism to prevent blood pressure from exceeding a pressure threshold.

45. The device of claim 42, wherein the occluder comprises an elastomeric balloon.

30 46. The device of claim 42, wherein the occluder comprises a resilient pre-shaped ring.

47. The device of claim 42, wherein the occluder comprises a beveled lip at the distal end of the catheter, whereby blood flow exerts an outward force on the beveled
35 lip.

48. The device of claim 42, wherein the occluder comprises a plurality of graduated rings at the distal end of the catheter, whereby blood flow exerts an outward force on the graduated rings.

5 49. The device of claim 42, wherein the constrictor further comprises an anchoring structure disposed about the periphery of the occluder.

50. The device of claim 49, wherein the anchoring structure comprises a plurality of ribs disposed about the constrictor.

10

51. The device of claim 42, wherein the constrictor includes an outer conical shell having an open base and a plurality of ports traversing the wall of the outer shell.

15 52. The device of claim 51, further comprising an inner conical shell having a plurality of ports and rotatably disposed within the outer conical shell.

53. The device of claim 52, wherein the inner conical shell is coupled to a distal end of a torque cable.

20 54. The device of claim 53, wherein the torque cable is coupled to a rotary unit.

55. The device of claim 52, wherein the ports of the inner shell align with the ports of the outer shell.

25

56. The device of claim 52, wherein the outer and the inner shells include mutually engaging threaded collars.

30 57. The device of claim 51, wherein the diameter of the ports in the outer shell is approximately between 2 and 5 millimeters.

58. The device of claim 51, wherein the constrictor further includes a blood lumen extending from the opening to the ports.

59. The device of claim 51, wherein the constrictor further includes a plurality of resilient flaps mounted to either the base or apex of the outer conical shell and connected to a plurality of pull wires.

5 60. The device of claim 59, wherein a longitudinal positioning unit is coupled to the plurality of pull wires.

61. The device of claim 52, wherein each conical shell includes a collar affixed to the distal end of the catheter.

10

62. The device of claim 42, wherein the occluder comprises a cylindrical expandable balloon having an outer surface, a lumen, and an enclosed chamber.

63. The device of claim 62, wherein the occluder further includes a distal opening and a proximal opening, and wherein blood flows from the distal opening to the proximal opening.

15

64. The device of claim 62, further comprising an inflatable ring disposed about the cylindrical balloon and communicating with an inflation lumen.

20

65. The device of claim 64, wherein the inflation lumen communicates with syringe at the proximal end of the catheter.

66. A medical device for partial aortic occlusion for cerebral perfusion augmentation, comprising:

25

an elongate member having proximal and distal ends, the distal end adapted for insertion through the femoral artery into the descending aorta;

an expandable constrictor mounted at the distal end of the elongate member, the constrictor expandable to engage the lumen of the aorta and having one or more adjustable passages through which distal blood flow may be carried;

30

a manometer mounted distal the expandable constrictor for measuring blood pressure in the proximal aorta; and

a catheter extending beyond the constrictor and independently operable to access the carotid arteries, the coronary arteries, the aortic wall, and the conducting tissue of the heart and myocardium, the catheter carrying a medical device.

35

67. The device of claim 66, wherein the catheter extends through the constrictor.

5 68. The device of claim 66, wherein the catheter extends through a lumen adjacent the constrictor.

10 69. The device of claim 66, further comprising a variable flow mechanism in operative association with the adjustable passages for controlling blood flow through the passages.

70. The device of claim 66, wherein the catheter includes aspiration capabilities.

15 71. The device of claim 66, wherein the medical device is an atherectomy catheter.

72. The device of claim 66, wherein the medical device is an infusion catheter.

20 73. The device of claim 66, wherein the medical device is an EPS catheter.

74. A method for inducing production of neuroprotective or thrombolytic agents in the brain, comprising the steps of:

25 providing a catheter having a proximal end, a distal end, and an expandable constrictor mounted on the distal end;

inserting the distal end of the catheter into the descending aorta in a retrograde or antegrade direction;

locating the constrictor upstream from the takeoff of the left common carotid artery; and

30 expanding the constrictor to partially occlude blood flow in the aorta, wherein blood flow to the brain decreases and the brain is conditioned to secrete neuroprotective agents in response to the decreased perfusion.

35 75. The method of claim 74, wherein the constrictor is located upstream from the innominate artery.

76. The method of claim 74, wherein blood flow at the partial occlusion is varied.

5 77. A method for increasing blood flow to a patient's cerebral vasculature, comprising the steps of:

attaching a constrictor to a catheter having a proximal end and a distal end, the constrictor being expandable and having a lumen;

inserting the distal end of the catheter into the descending aorta;

10 locating the constrictor downstream from the takeoff of the brachiocephalic artery; and

expanding the constrictor to partially occlude blood flow in the aorta, wherein blood pressure in the proximal aorta increases and blood pressure in the distal aorta decreases.

15 78. The method of claim 77, wherein the lumen of the constrictor is adapted for blood flow.

20 79. The method of claim 77, wherein the constrictor further comprises a second lumen adapted to receive a medical instrument.

80. The method of claim 77, wherein the constrictor is used to treat shock.

81. The method of claim 80, wherein the shock is hemorrhagic shock.

25 82. The method of claim 77, wherein the constrictor is used to treat vasospasm.

83. The method of claim 82, wherein the vasospasm is iatrogenic.

30 84. The method of claim 82, wherein the vasospasm is subarachnoid hemorrhage-induced.

35 85. The method of claim 77, further comprising the step of advancing a medical instrument through the lumen of the constrictor and into an artery that branches from the aorta.

86. The method of claim 77, wherein the step of expanding the constrictor comprises reducing the luminal diameter of the constrictor to reduce blood flow, while an outer diameter of the constrictor remains constant.

5 87. The method of claim 77, wherein the catheter is selected from the group consisting of a guiding catheter, an infusion catheter, an angioplasty catheter, a laser catheter, an angiography catheter, a therapeutic ultrasound catheter, a hypothermia catheter, a stent catheter, an imaging catheter, a perfusion catheter, an atherectomy catheter, an occlusion catheter, an EP catheter, and an aspiration catheter.

10

88. The method of claim 77, wherein the step of expanding the constrictor includes maintaining the expanded constrictor during systole.

15 89. The method of claim 85, wherein the medical instrument is selected from the group consisting of a guiding catheter, an infusion catheter, an angioplasty catheter, a laser catheter, an angiography catheter, a therapeutic ultrasound catheter, a hypothermia catheter, a stent catheter, an imaging catheter, a perfusion catheter, an atherectomy catheter, an occlusion catheter, an EP catheter, and an aspiration catheter.

20 90. The method of claim 77, wherein the constrictor comprises a toroidal balloon, and wherein the step of expanding the constrictor comprises inflating the constrictor.

25 91. The method of claim 77, wherein the constrictor comprises a spring disposed circumferentially about a flexible luminal wall of the constrictor.

92. The method of claim 90, further comprising the step of slowly deflating the constrictor.

30 93. A medical device for increasing blood flow to a patient's cerebral vasculature, comprising:

a catheter having a proximal end and a distal end; and

35 a constrictor removably attachable to the catheter, the constrictor having a lumen with a variable diameter for blood flow, the constrictor being operable to reduce and enlarge the diameter of the lumen in order to regulate blood flow.

94. The medical device of claim 93, wherein the catheter is selected from the group consisting of a guiding catheter, an infusion catheter, an angioplasty catheter, a laser catheter, an angiography catheter, a therapeutic ultrasound catheter, a hypothermia catheter, a stent catheter, an imaging catheter, a perfusion catheter, an atherectomy catheter, an occlusion catheter, an EP catheter, and an aspiration catheter.

95. The medical device of claim 93, wherein the constrictor comprises a toroidal balloon.

96. The medical device of claim 93, wherein the constrictor comprises a spring disposed circumferentially about a flexible luminal wall of the constrictor.

97. A method for increasing blood flow to a patient's cerebral vasculature, comprising the steps of:

providing a catheter having a proximal end, a distal end, and an expandable constrictor mounted on the distal end, and a lumen extending from the proximal end and communicating with a port distal the constrictor;

inserting the distal end of the catheter into the descending aorta;

locating the constrictor downstream from the takeoff of the brachiocephalic artery;

expanding the constrictor to partially occlude blood flow in the aorta, wherein blood pressure in the proximal aorta increases and blood pressure in the distal aorta decreases; and

advancing a medical instrument through the lumen, beyond the distal port, and into an artery which branches from the aorta.

98. The method of claim 97, wherein the step of expanding the constrictor includes maintaining the expanded constrictor during systole.

99. The method of claim 97, wherein the medical instrument is selected from the group consisting of a guiding catheter, an infusion catheter, an angioplasty catheter, a laser catheter, an angiography catheter, a therapeutic ultrasound catheter, a hypothermia catheter, a stent catheter, an imaging catheter, a perfusion catheter, an atherectomy catheter, an occlusion catheter, an EP catheter, and an aspiration catheter.

100. A method for increasing blood flow to a patient's cerebral vasculature, comprising the steps of:

5 providing a catheter having a proximal end, a distal end, and an expandable constrictor mounted on the distal end, and a lumen extending from the proximal end and communicating with a port distal the constrictor;

inserting the distal end of the catheter into the descending aorta;

10 locating the constrictor downstream from the takeoff of the brachiocephalic artery;

expanding the constrictor to partially occlude blood flow in the aorta, wherein blood pressure in the proximal aorta increases and blood pressure in the distal aorta decreases; and

15 advancing an interventional instrument through the lumen and beyond the distal port.

101. The method of claim 100, wherein the step of expanding the constrictor includes maintaining the expanded constrictor during systole.

20 102. The method of claim 100, wherein the interventional instrument is selected from the group consisting of an infusion catheter, an angioplasty catheter, a laser catheter, an angiography catheter, a therapeutic ultrasound catheter, a hypothermia catheter, a stent catheter, an imaging catheter, a perfusion catheter, an atherectomy catheter, an occlusion catheter, an EP catheter, and an aspiration catheter.

103. A method for increasing blood flow to a patient's cerebral vasculature, comprising the steps of:

providing a catheter having a proximal end, a distal end, and an expandable constrictor mounted on the distal end;

5 inserting the distal end of the catheter into the descending aorta;

locating the constrictor downstream from the takeoff of the brachiocephalic artery;

10 expanding the constrictor to partially occlude blood flow in the aorta and maintaining the expanded constrictor during systole, wherein blood pressure in the proximal aorta increases and blood pressure in the distal aorta decreases, and wherein blood flow to the cerebral vasculature increases and exaggerates the pulse wave to enhance the pulsatile wave form;

measuring a first blood pressure at a location distal the constrictor; and

15 adjusting the constrictor based on the first measured blood pressure.

104. The method of claim 103, further comprising the step of measuring a second blood pressure at a location proximal the constrictor, and wherein the constrictor is adjusted based on a comparison of the first and second measured blood pressures.

20 105. A method for increasing blood flow to a patient's cerebral vasculature, comprising the steps of:

providing a catheter having a proximal end, a distal end, and an expandable constrictor mounted on the distal end;

inserting the distal end of the catheter into the descending aorta;

25 locating the constrictor downstream from the takeoff of the brachiocephalic artery;

expanding the constrictor to partially occlude blood flow in the aorta, wherein blood pressure in the proximal aorta increases and blood pressure in the distal aorta decreases;

30 measuring a first blood pressure at a location proximal the constrictor and measuring a second blood pressure at a location distal the constrictor; and

adjusting the constrictor based on a comparison of the first and second measured blood pressures.

35 106. The method of claim 105, wherein the step of expanding the constrictor includes maintaining the expanded constrictor during systole.

107. A method for increasing blood flow to a patient's cerebral vasculature, comprising the steps of:

providing a catheter having a proximal end, a distal end, and an expandable constrictor mounted on the distal end;

5 inserting the distal end of the catheter into the descending aorta;

locating the constrictor downstream from the takeoff of the brachiocephalic artery; and

10 expanding the constrictor to partially occlude blood flow in the aorta and maintaining the expanded constrictor during systole, wherein blood pressure in the proximal aorta increases and blood pressure in the distal aorta decreases, and wherein blood flow to the cerebral vasculature increases by at least 20% and exaggerates the pulse wave to enhance the pulsatile wave form.

108. A method for increasing blood flow to a patient's cerebral vasculature, comprising the steps of:

15 providing a catheter having a proximal end, a distal end, and an expandable constrictor mounted on the distal end, wherein the constrictor is a balloon having proximal and distal ends separated by a length of no more than 20 cm;

inserting the distal end of the catheter into the descending aorta;

20 locating the constrictor downstream from the takeoff of the brachiocephalic artery; and

25 expanding the constrictor to partially occlude blood flow in the aorta and maintaining the expanded constrictor during systole, wherein blood pressure in the proximal aorta increases and blood pressure in the distal aorta decreases, and wherein blood flow to the cerebral vasculature increases and exaggerates the pulse wave to enhance the pulsatile wave form.

109. A method for increasing blood flow to a patient's cerebral vasculature, comprising the steps of:

providing a catheter having a proximal end, a distal end, and an expandable constrictor mounted on the distal end;

5 inserting the distal end of the catheter into the descending aorta;

locating the constrictor downstream from the takeoff of the brachiocephalic artery; and

10 expanding the constrictor to partially occlude blood flow in the aorta and maintaining the expanded constrictor during systole, wherein blood pressure in the proximal aorta increases and blood pressure in the distal aorta decreases, and wherein blood flow to the cerebral vasculature increases and exaggerates the pulse wave to enhance the pulsatile wave form.

110. A method for inducing production of neuroprotective agents in the spinal cord, comprising the steps of:

15 providing a catheter having a proximal end, a distal end, and an expandable constrictor mounted on the distal end;

inserting the distal end of the catheter into the descending aorta in a retrograde or antegrade direction;

20 locating the constrictor downstream from the takeoff of the brachiocephalic artery and upstream from the lumbar or spinal arteries; and

expanding the constrictor to partially occlude blood flow in the aorta, wherein blood flow to the spinal cord decreases and the spinal cord is conditioned to secrete neuroprotective agents in response to the decreased perfusion.

25

111. The method of claim 110, further comprising the step of performing abdominal aortic aneurysm repair on the patient.

112. The method of claim 110, wherein blood flow is partially occluded upstream from the lumbar or spinal arteries.

30

113. The method of claim 110, wherein blood flow at the partial occlusion is varied.

114. A method for decreasing blood pressure in a patient's renal artery, comprising the steps of:

providing a catheter having a proximal end, a distal end, and an expandable constrictor mounted on the distal end;

5 inserting the distal end of the catheter into the descending aorta;

locating the constrictor in a renal artery; and

expanding the constrictor to partially occlude blood flow in the renal artery, wherein blood pressure in the distal renal artery decreases.

10 115. The method of claim 114, wherein the patient is hypertensive.

116. The method of claim 114, wherein the constrictor is inserted in each of the right and/or left renal arteries.

15 117. The method of claim 115, wherein the hypertensive condition is renal artery stenosis.

118. A method for increasing blood flow to a patient's cerebral vasculature, comprising the steps of:

20 providing a catheter having a proximal end, a distal end, and an expandable constrictor mounted on the distal end;

inserting the distal end of the catheter into the descending aorta;

locating the constrictor downstream from the takeoff of the brachiocephalic artery; and

25 expanding the constrictor to partially occlude blood flow in the aorta and maintaining the expanded constrictor during systole, wherein blood pressure in the proximal aorta increases and blood pressure in the distal aorta decreases, and wherein blood flow to the cerebral vasculature increases.

30 119. The method of claim 118, wherein the partial occlusion of aortic blood flow is continuous.

120. The method of claim 118, wherein aortic blood flow is partially occluded downstream from the takeoff of the left subclavian artery or the brachiocephalic artery.

121. The method of claim 118, wherein aortic blood flow is partially occluded upstream from the takeoff of the left subclavian artery.

5 122. The method of claim 118, wherein the patient suffers from global cerebral ischemia and blood flow to the cerebral vasculature is increased.

10 123. The method of claim 118, wherein the patient suffers from focal cerebral ischemia or asymptomatic vasospasm and blood flow to the cerebral vasculature is increased.

124. The method of claim 118, further comprising the step of inserting the distal end of the catheter through an incision on a peripheral artery.

15 125. The method of claim 124, wherein the peripheral artery is the femoral artery.

126. The method of claim 124, wherein the peripheral artery is the subclavian artery.

20 127. The method of claim 118, wherein blood flow through the partial occlusion is varied.

25 128. The method of claim 118, wherein at least one of the blood pressure upstream and downstream from the partial occlusion is measured, and wherein blood flow at the partial occlusion is varied based on the blood pressure measurement.

129. The method of claim 118, further comprising the step of removing a thromboembolic material from the carotid artery.

30 130. The method of claim 118, further comprising the step of localizing the constrictor with transesophageal echocardiography.

35 131. The method of claim 118, further comprising the step of localizing the constrictor with angiogram.

132. The method of claim 118, wherein the distal end of the catheter is inserted into the descending aorta in a antegrade direction.

5 133. The method of claim 118, wherein the constrictor is located in the aorta upstream from the renal arteries.

134. A medical device for partial aortic occlusion for cerebral perfusion augmentation, comprising:

10 an elongate member having proximal and distal ends, the distal end adapted for insertion through the femoral artery into the descending aorta;

an expandable constrictor mounted at the distal end of the elongate member, the constrictor expandable to engage the lumen of the aorta and having one or more adjustable passages through which distal blood flow may be carried; and

15 a manometer mounted distal the expandable constrictor for measuring blood pressure in the proximal aorta.

135. The device of claim 134, wherein the manometer includes a pressure tube extending distally from the catheter and proximally connected to a pressure monitor.

20 136. The device of claim 134, further comprising a pressure limiter in operative association with the manometer to receive blood pressure measurements, and a variable flow mechanism to prevent blood pressure from exceeding a pressure threshold.

25 137. The device of claim 134, wherein the occluder comprises an elastomeric balloon.

138. The device of claim 134, wherein the occluder comprises a resilient pre-shaped ring.

30 139. The device of claim 134, wherein the occluder comprises a beveled lip at the distal end of the catheter, whereby blood flow exerts an outward force on the beveled lip.

35 140. The device of claim 134, wherein the occluder comprises a plurality of graduated rings at the distal end of the catheter, whereby blood flow exerts an outward force on the graduated rings.

141. The device of claim 134, wherein the constrictor further comprises an anchoring structure disposed about the periphery of the occluder.

5 142. The device of claim 141, wherein the anchoring structure comprises a plurality of ribs disposed about the constrictor.

143. The device of claim 134, wherein the constrictor includes an outer conical shell having an open base and a plurality of ports traversing the wall of the outer shell.

10

144. The device of claim 143, further comprising an inner conical shell having a plurality of ports and rotatably disposed within the outer conical shell.

145. The device of claim 144, wherein the inner conical shell is coupled to a distal end of a torque cable.

15

146. The device of claim 145, wherein the torque cable is coupled to a rotary unit.

147. The device of claim 144, wherein the ports of the inner shell align with the ports of the outer shell.

20

148. The device of claim 144, wherein the outer and the inner shells include mutually engaging threaded collars.

25

149. The device of claim 143, wherein the diameter of the ports in the outer shell is approximately between 2 and 5 millimeters.

150. The device of claim 143, wherein the constrictor further includes a blood lumen extending from the opening to the ports.

30

151. The device of claim 143, wherein the constrictor further includes a plurality of resilient flaps mounted to either the base or apex of the outer conical shell and connected to a plurality of pull wires.

35

152. The device of claim 151, wherein a longitudinal positioning unit is coupled to the plurality of pull wires.

5 153. The device of claim 144, wherein each conical shell includes a collar affixed to the distal end of the catheter.

154. The device of claim 134, wherein the occluder comprises a cylindrical expandable balloon having an outer surface, a lumen, and an enclosed chamber.

10 155. The device of claim 154, wherein the occluder further includes a distal opening and a proximal opening, and wherein blood flows from the distal opening to the proximal opening.

15 156. The device of claim 154, further comprising an inflatable ring disposed about the cylindrical balloon and communicating with an inflation lumen.

157. The device of claim 156, wherein the inflation lumen communicates with syringe at the proximal end of the catheter.

20 158. A medical device for partial aortic occlusion for cerebral perfusion augmentation, comprising:

an elongate member having proximal and distal ends, the distal end adapted for insertion through the femoral artery into the descending aorta;

25 an expandable constrictor mounted at the distal end of the elongate member, the constrictor expandable to engage the lumen of the aorta and having one or more passages adjustable independently of the expansion of the constrictor through which distal blood flow may be carried;

a manometer mounted distal the expandable constrictor for measuring blood pressure in the proximal aorta; and

30 a catheter extending through the constrictor and independently operable to access the carotid arteries, the coronary arteries, the aortic wall, and the conducting tissue of the heart and myocardium, the catheter carrying a medical device.

35 159. The device of claim 158, further comprising a variable flow mechanism in operative association with the adjustable passages for controlling blood flow through the passages.

160. The device of claim 158, wherein the catheter includes aspiration capabilities.

5 161. The device of claim 158, wherein the medical device is an atherectomy catheter.

162. The device of claim 158, wherein the medical device is an infusion catheter.

10

163. The device of claim 158, wherein the medical device is an EPS catheter.

164. A method for inducing production of neuroprotective agents in the brain, comprising the steps of:

15

 providing a catheter having a proximal end, a distal end, and an expandable constrictor mounted on the distal end;

 inserting the distal end of the catheter into the descending aorta in a retrograde or antegrade direction;

20

 locating the constrictor upstream from the takeoff of the left common carotid artery; and

 expanding the constrictor to partially occlude blood flow in the aorta, wherein blood flow to the brain decreases and the brain is conditioned to secrete neuroprotective agents in response to the decreased perfusion.

25

165. The method of claim 164, wherein the constrictor is located upstream from the innominate artery.

166. The method of claim 164, wherein blood flow at the partial occlusion is varied.

30

167. The method of claim 97, wherein the step of expanding the constrictor brings the constrictor into contact with the aorta such that the constrictor remains in contact with the wall of the aorta during use.

168. The method of claim 167, wherein the expanded constrictor includes an aperture through which blood flows during use.

5 169. The method of claim 167, wherein the expanded constrictor allows blood flow through gaps between the lumen of the aorta and outer dimensions of the constrictor.

170. A medical device for partial aortic occlusion for cerebral perfusion augmentation, comprising:

10 an elongate member having proximal and distal ends, the distal end adapted for insertion through the femoral artery into the descending aorta;

an expandable constrictor mounted at the distal end of the elongate member, the constrictor expandable to engage the lumen of the aorta and having one or more passages adjustable independently of the expansion of the constrictor of the
15 through which distal blood flow may be carried; and

a catheter extending through the constrictor and independently operable to access the carotid arteries, the coronary arteries, the aortic wall, and the conducting tissue of the heart and myocardium, the catheter carrying a medical device.

FIG. 1

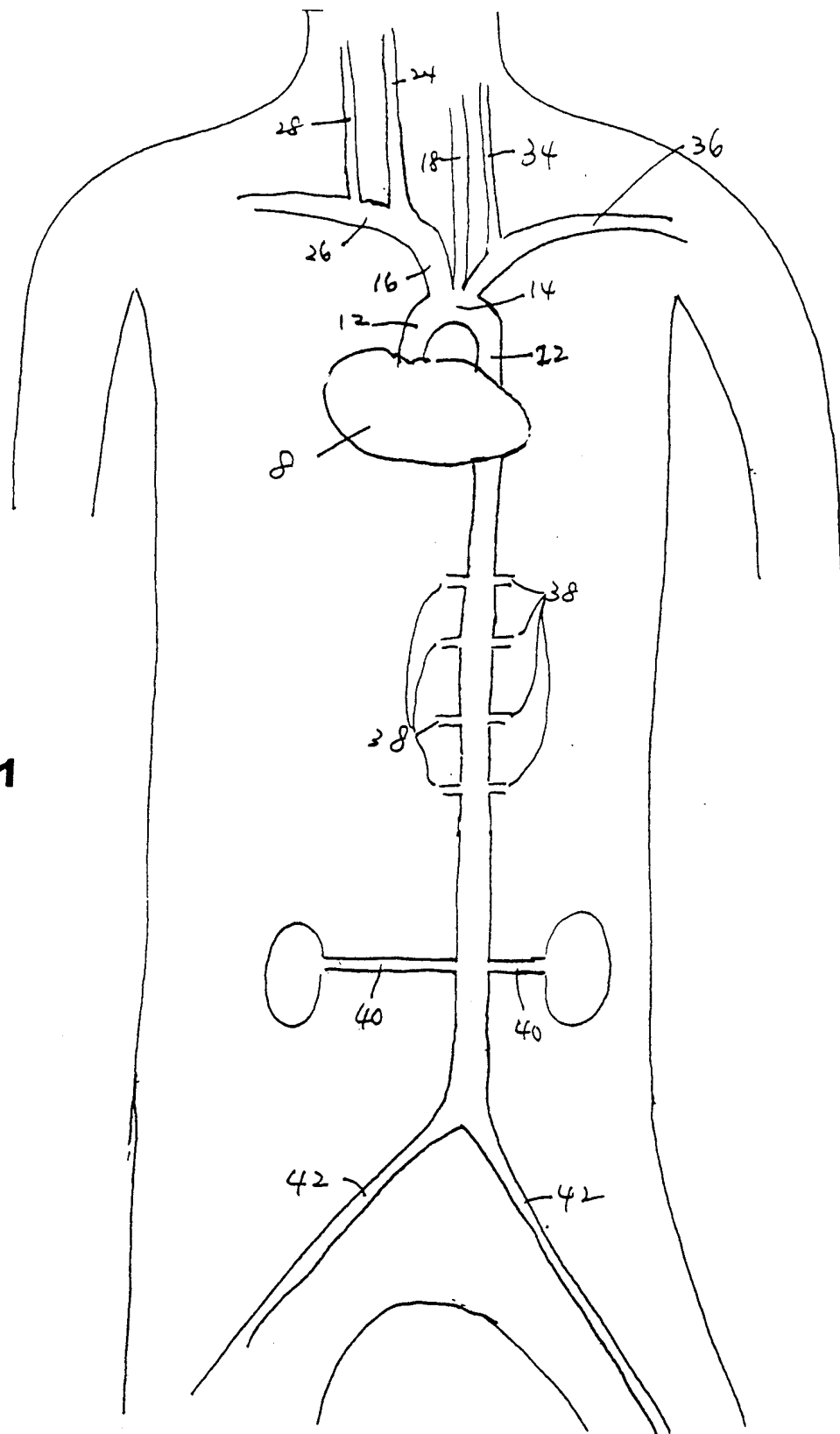

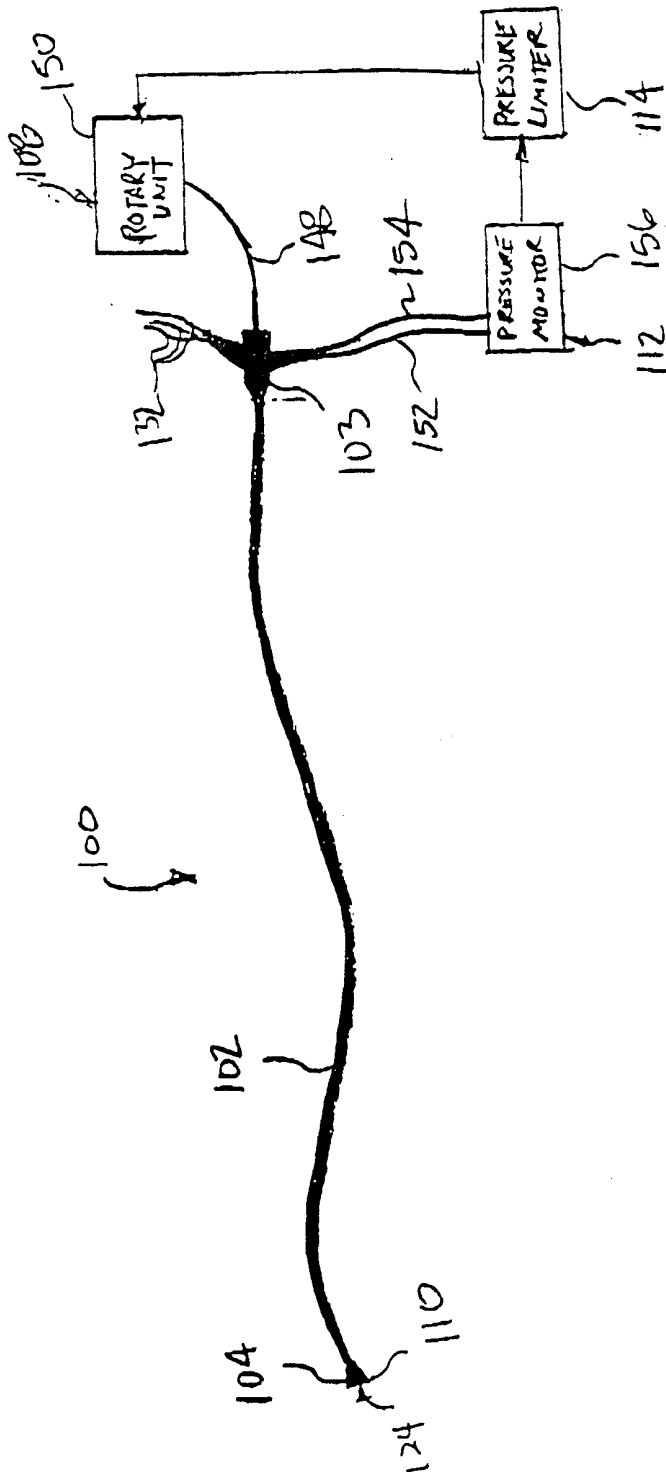
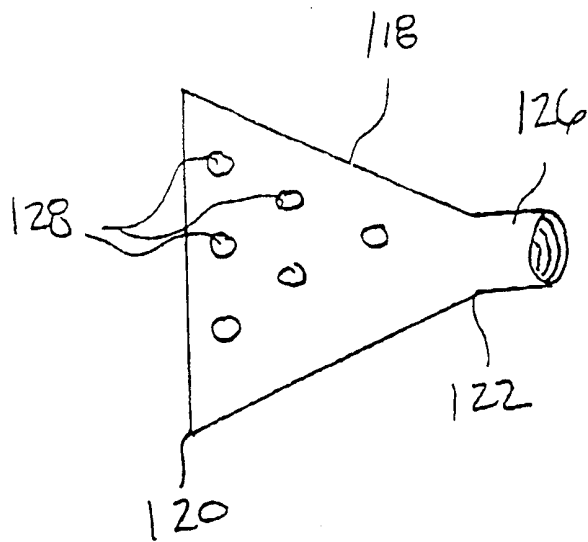
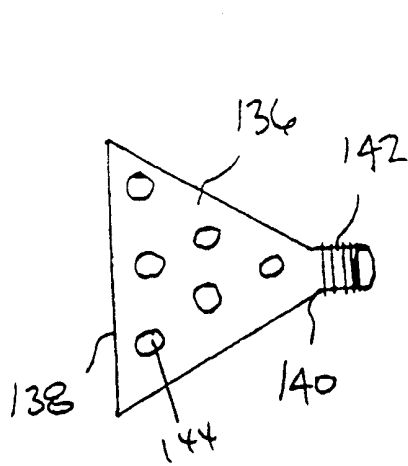
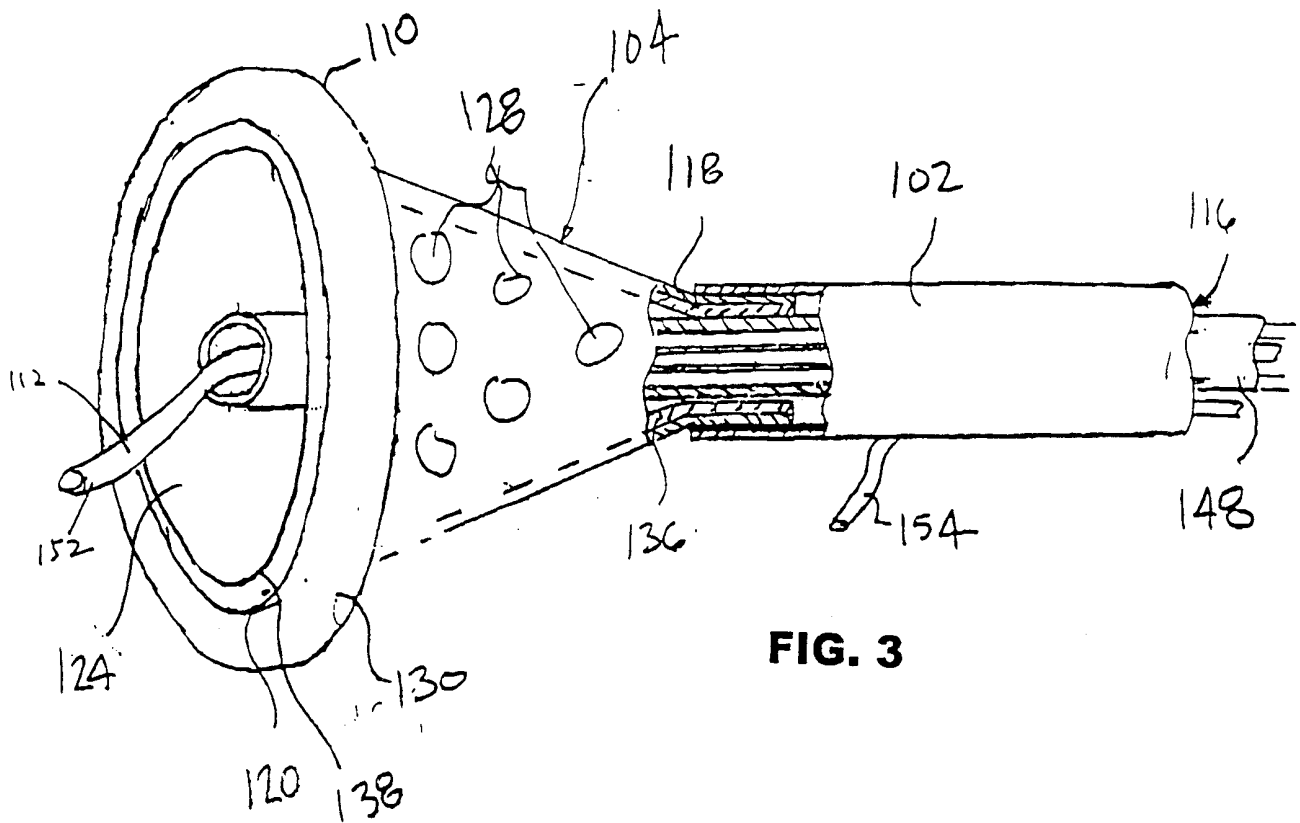

FIG. 2



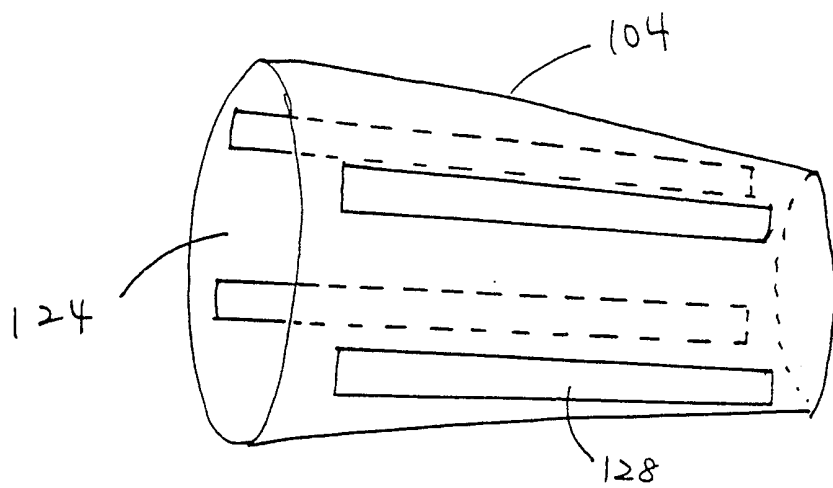

FIG. 5

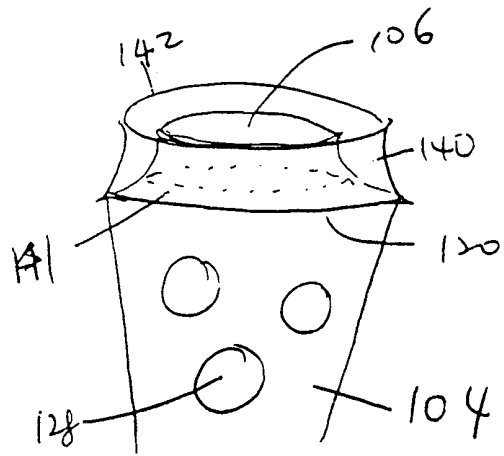

FIG. 6

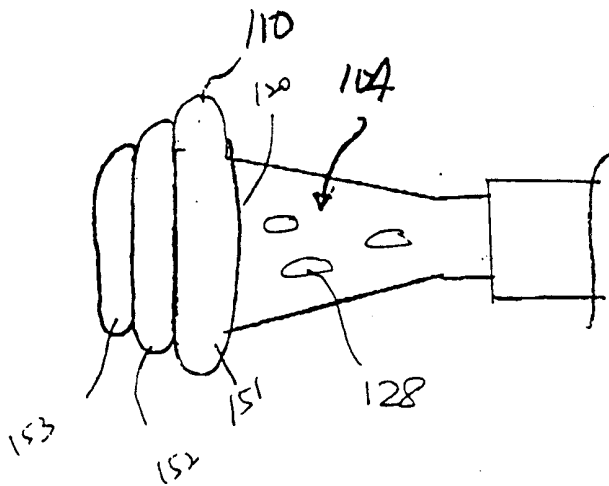

FIG. 7

FIG. 8

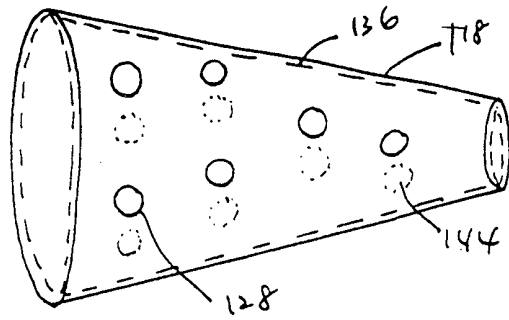

FIG. 9

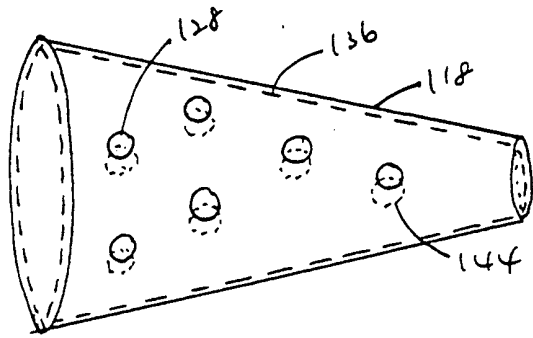
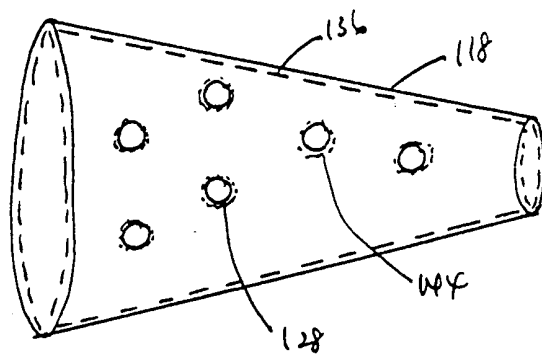

FIG. 10



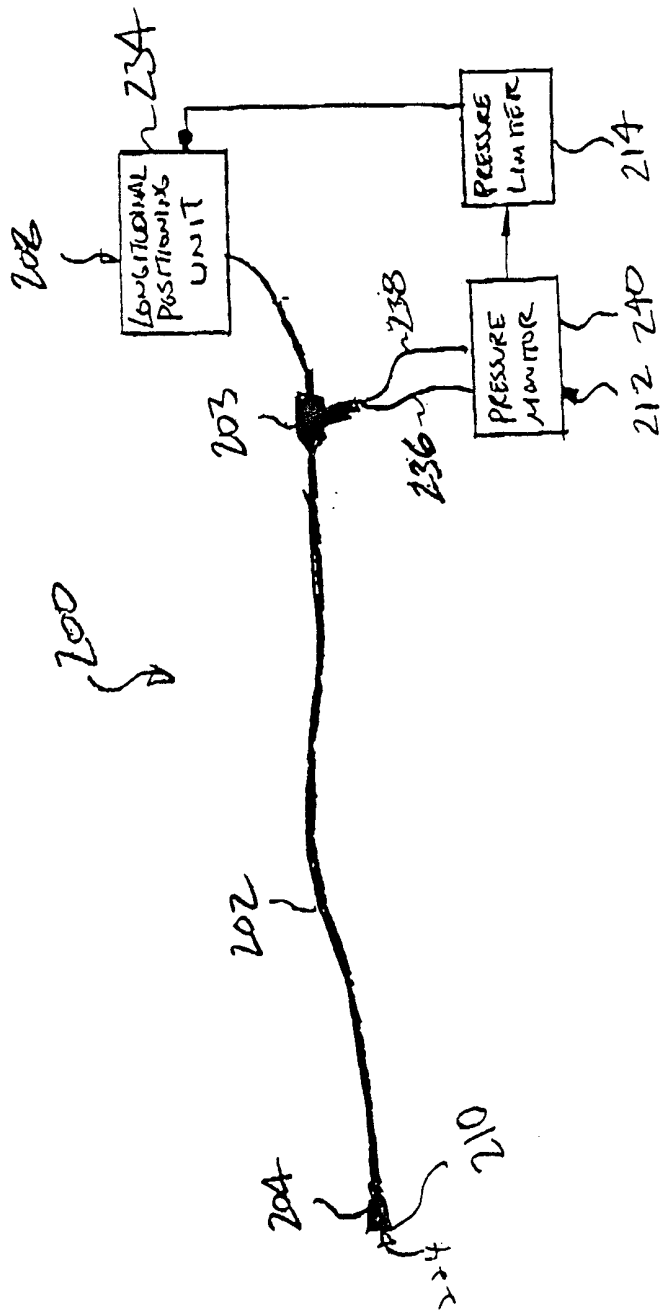

FIG. 11

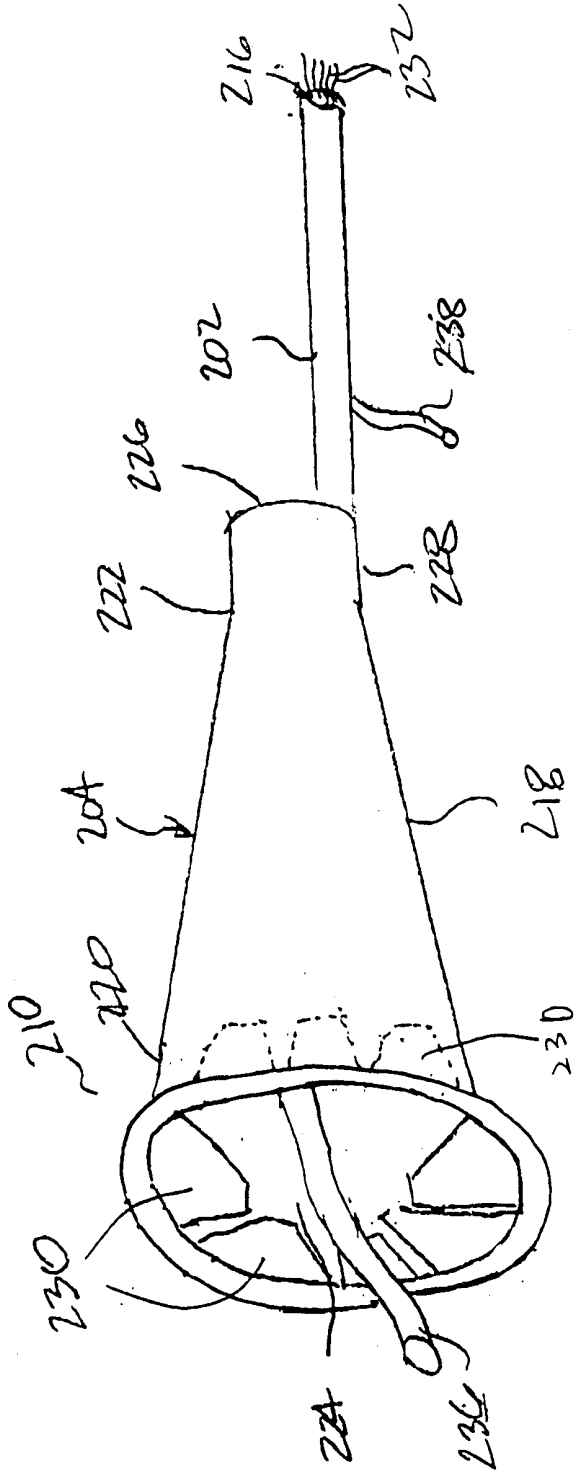

FIG. 12

FIG. 13C

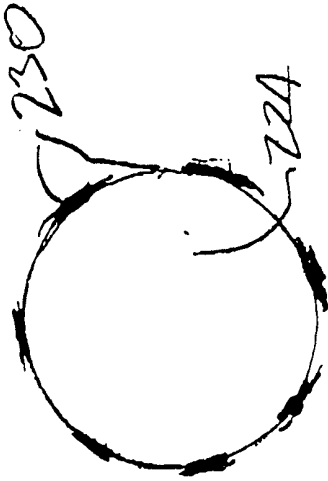

FIG. 13D

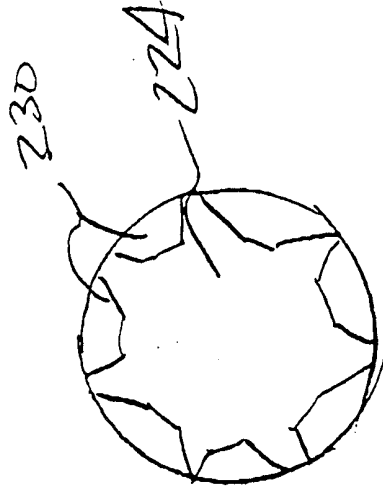

FIG. 13A

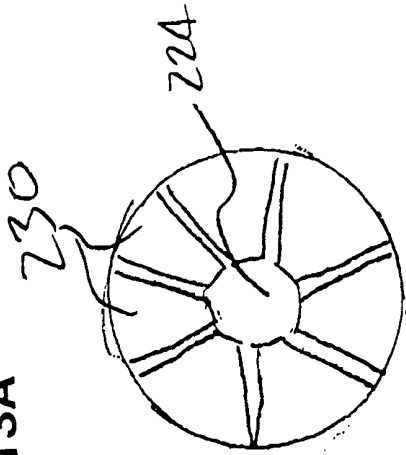

FIG. 13B



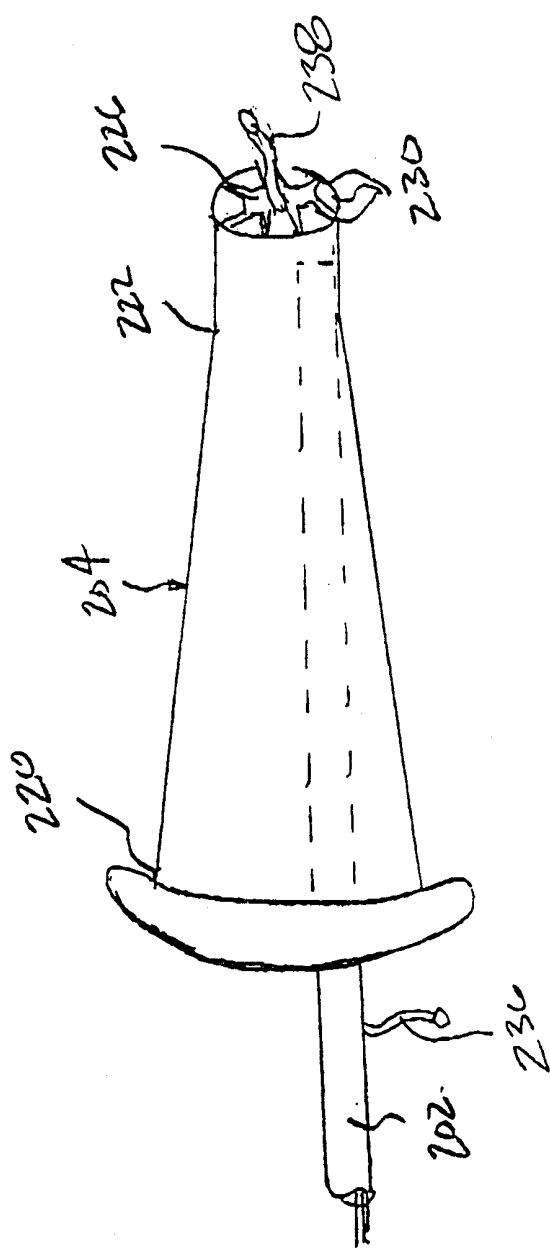

FIG. 14

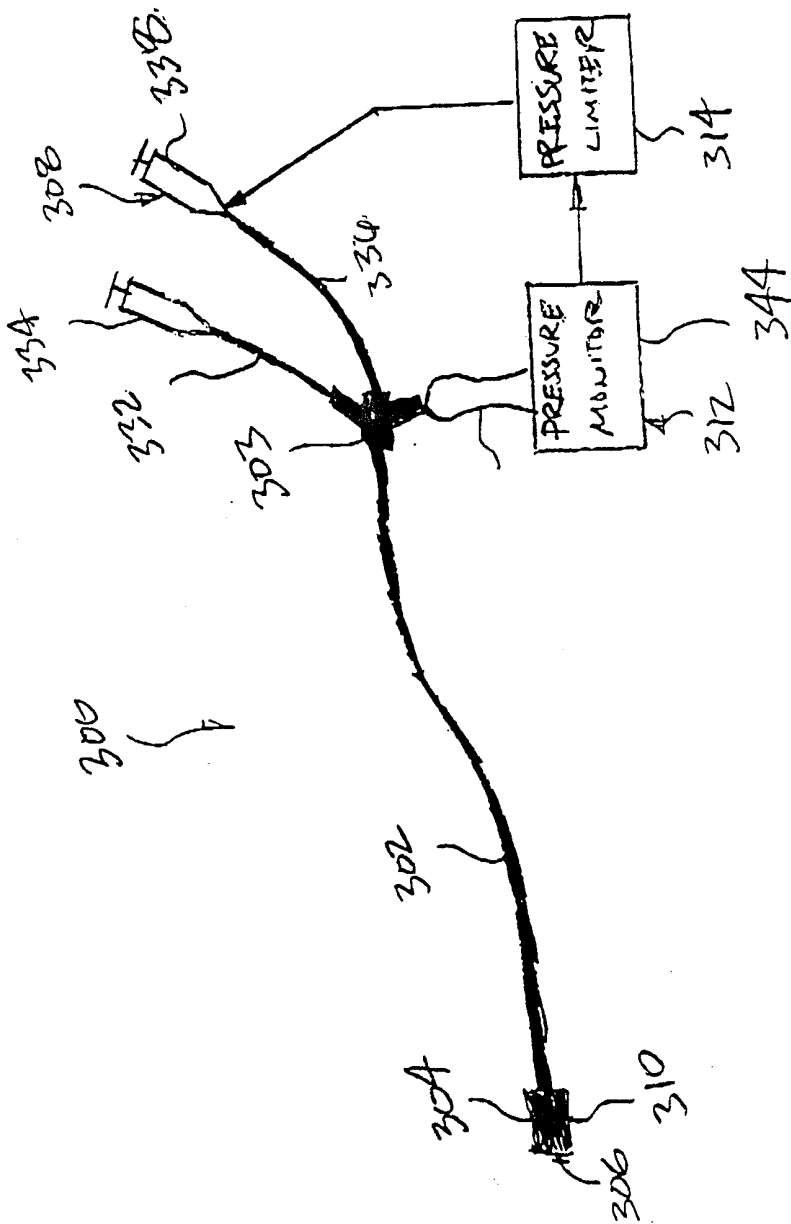

FIG. 15

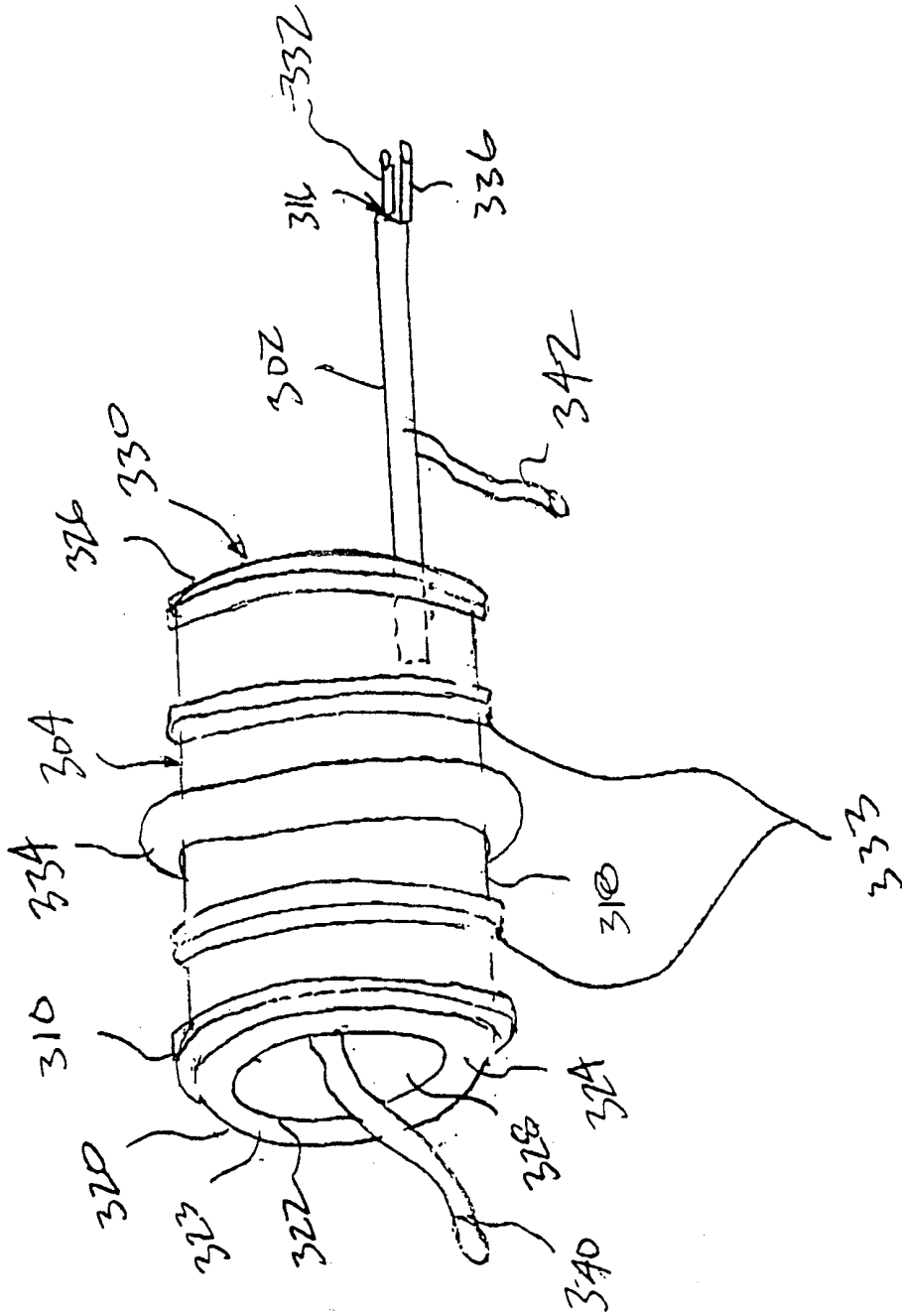

FIG. 16

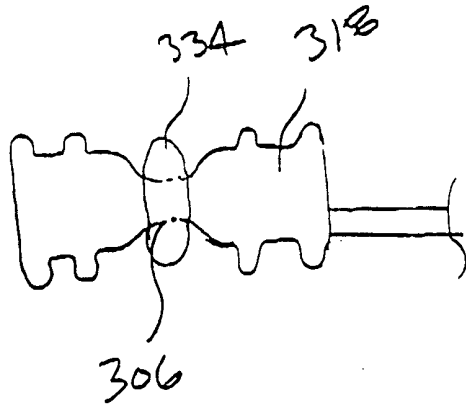

FIG. 17

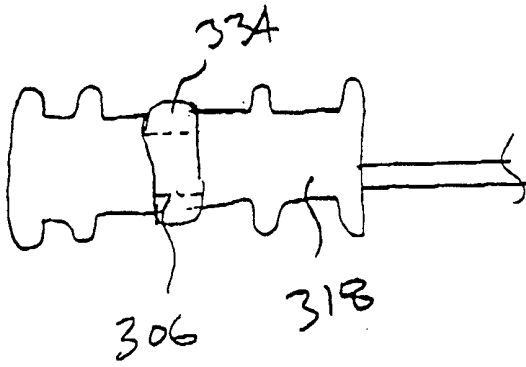

FIG. 18

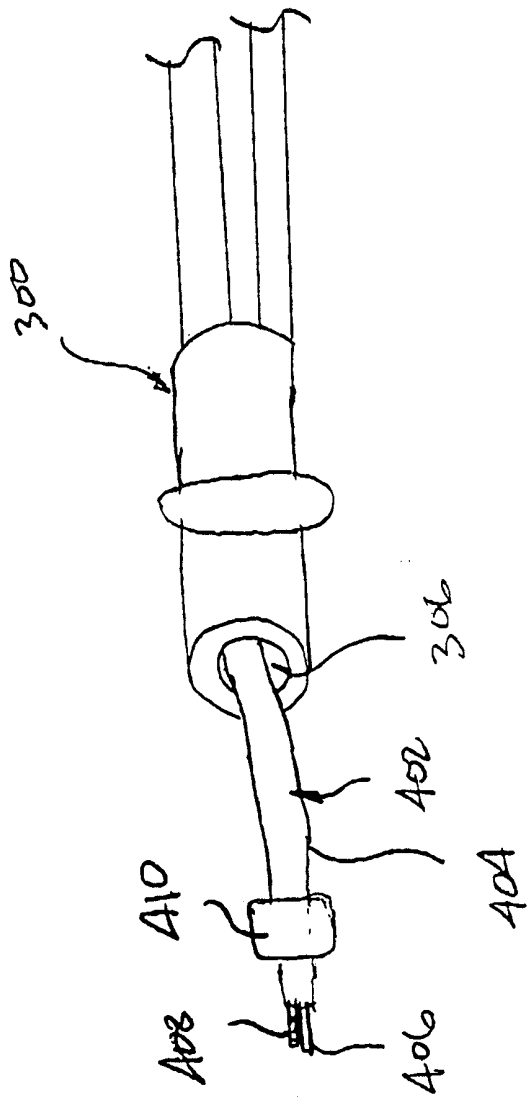

FIG. 19

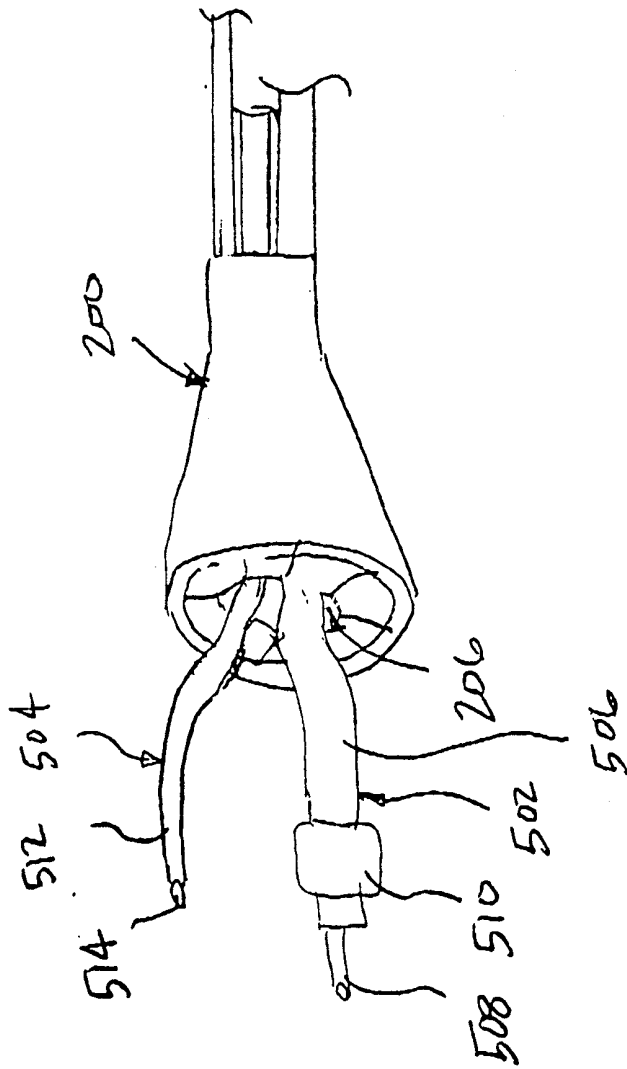

FIG. 20

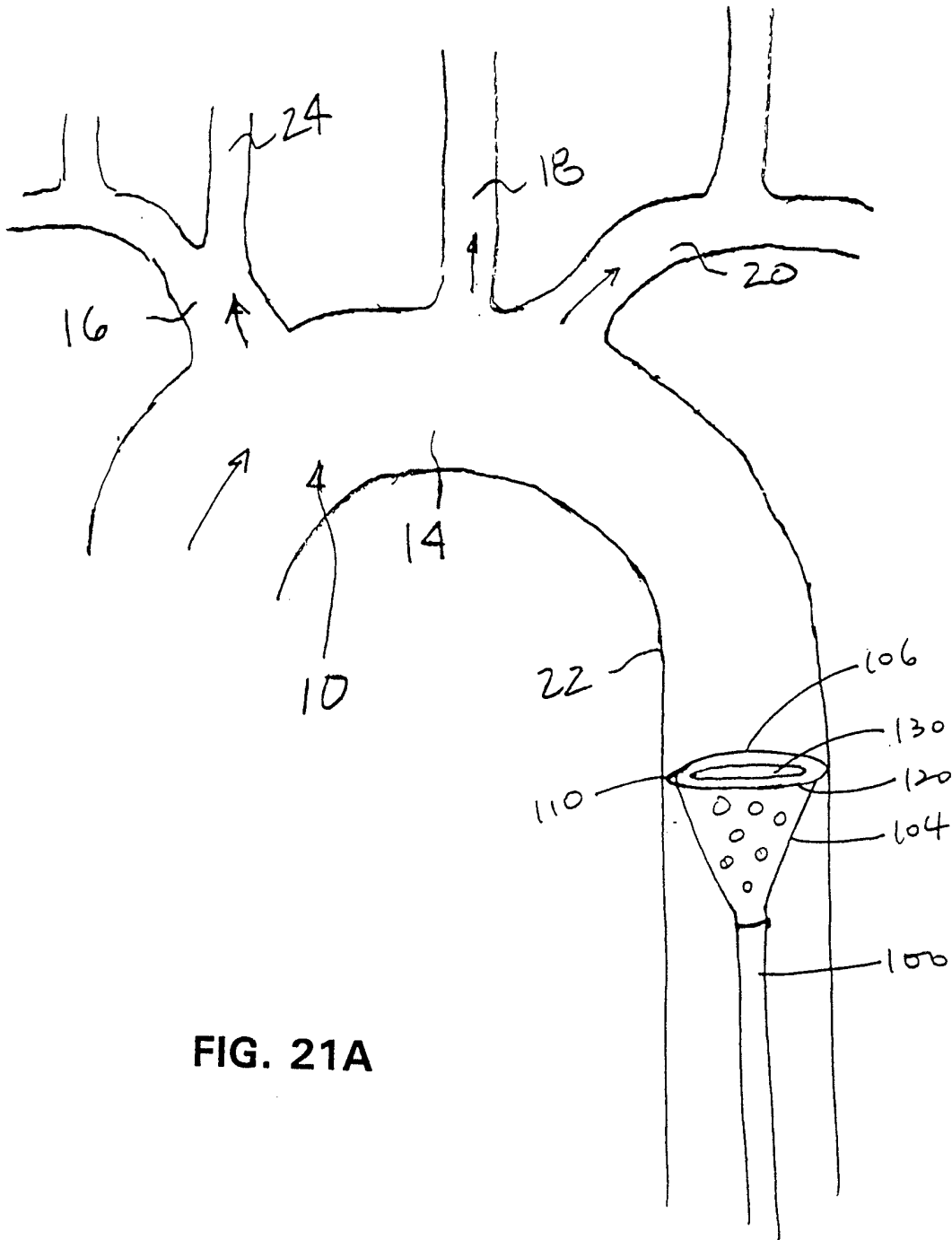

FIG. 21A

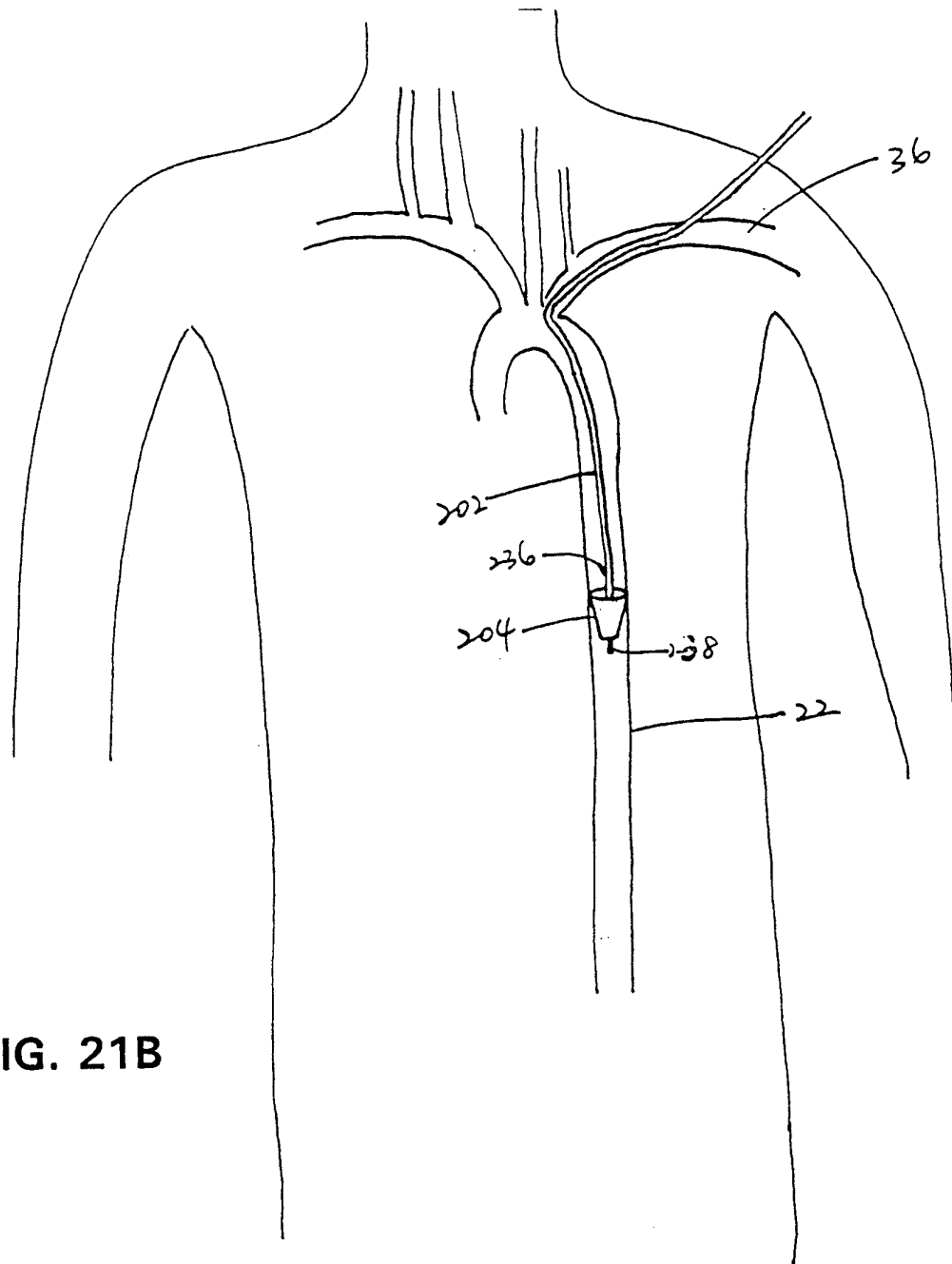

FIG. 21B

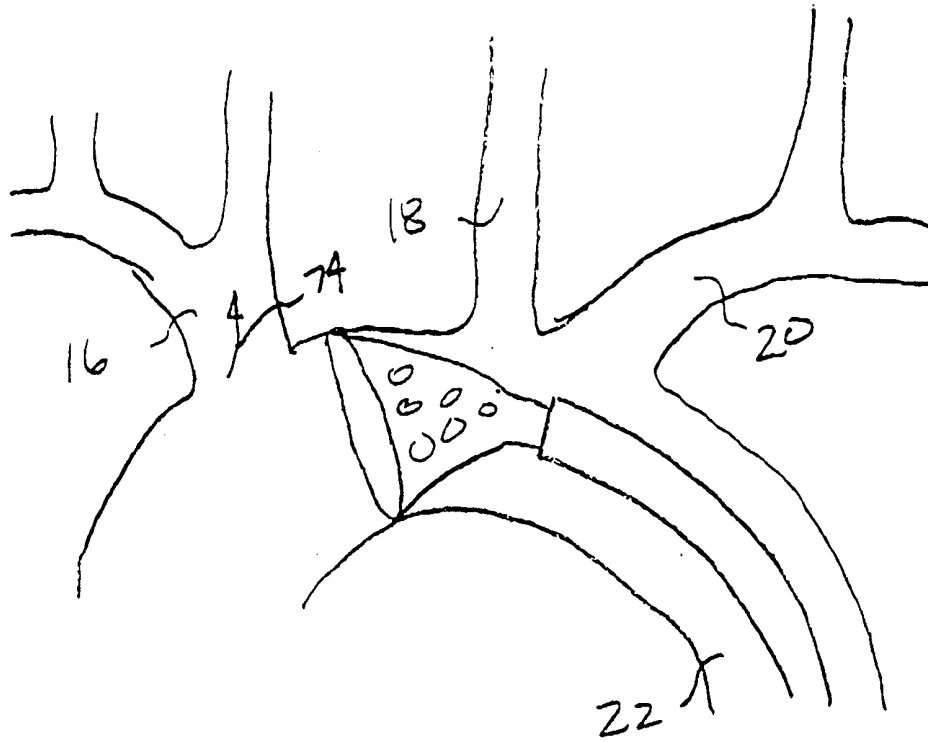

FIG. 22

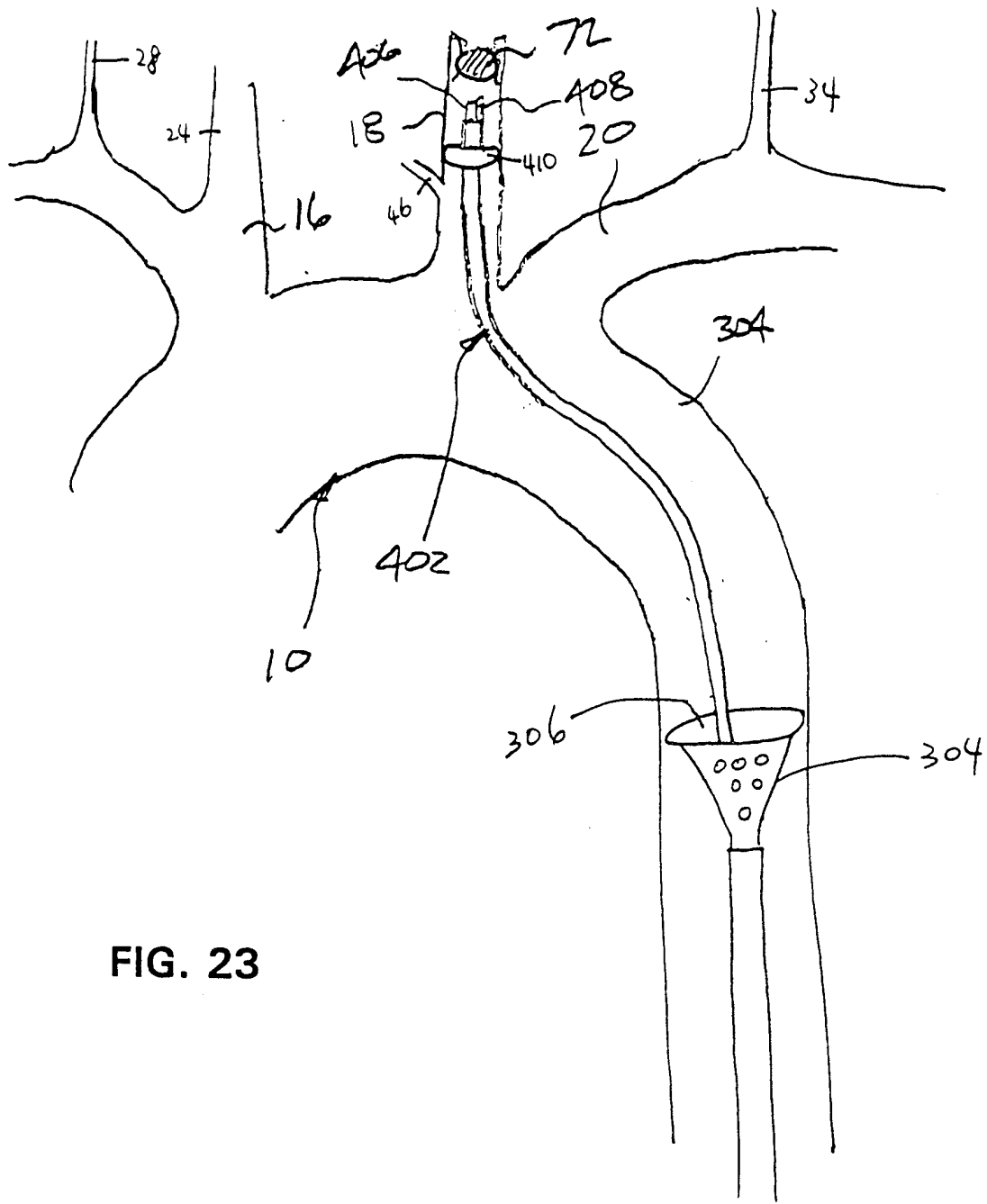

FIG. 23

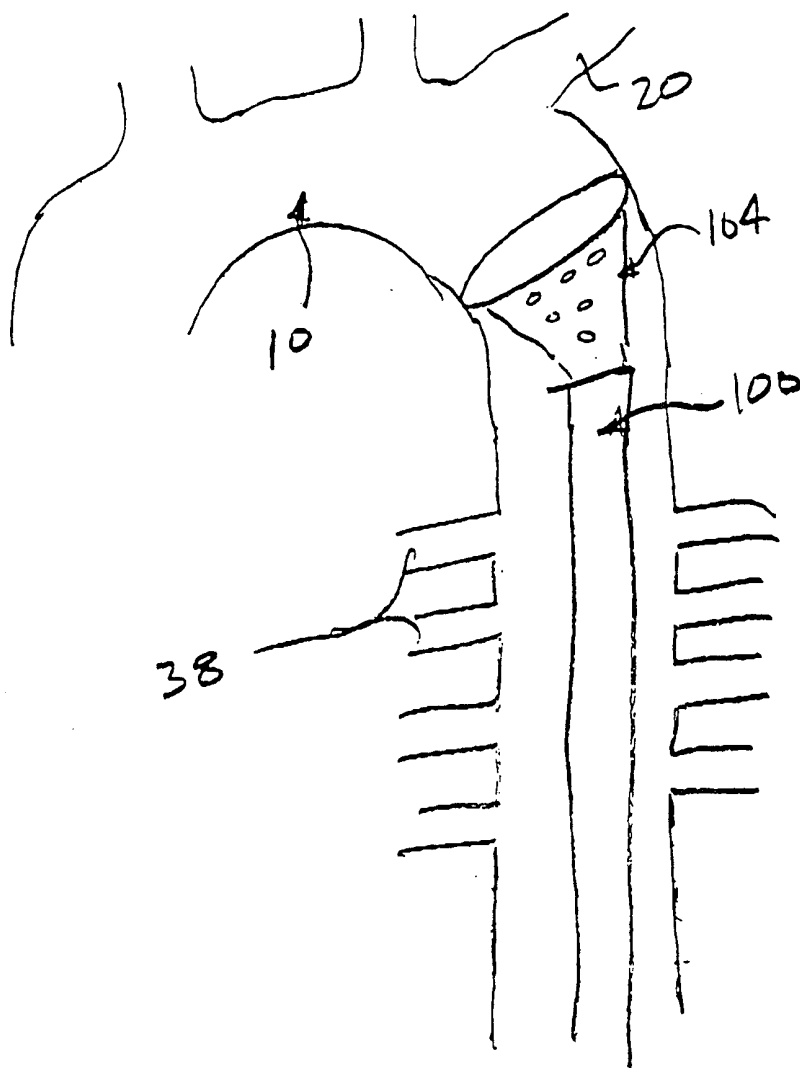
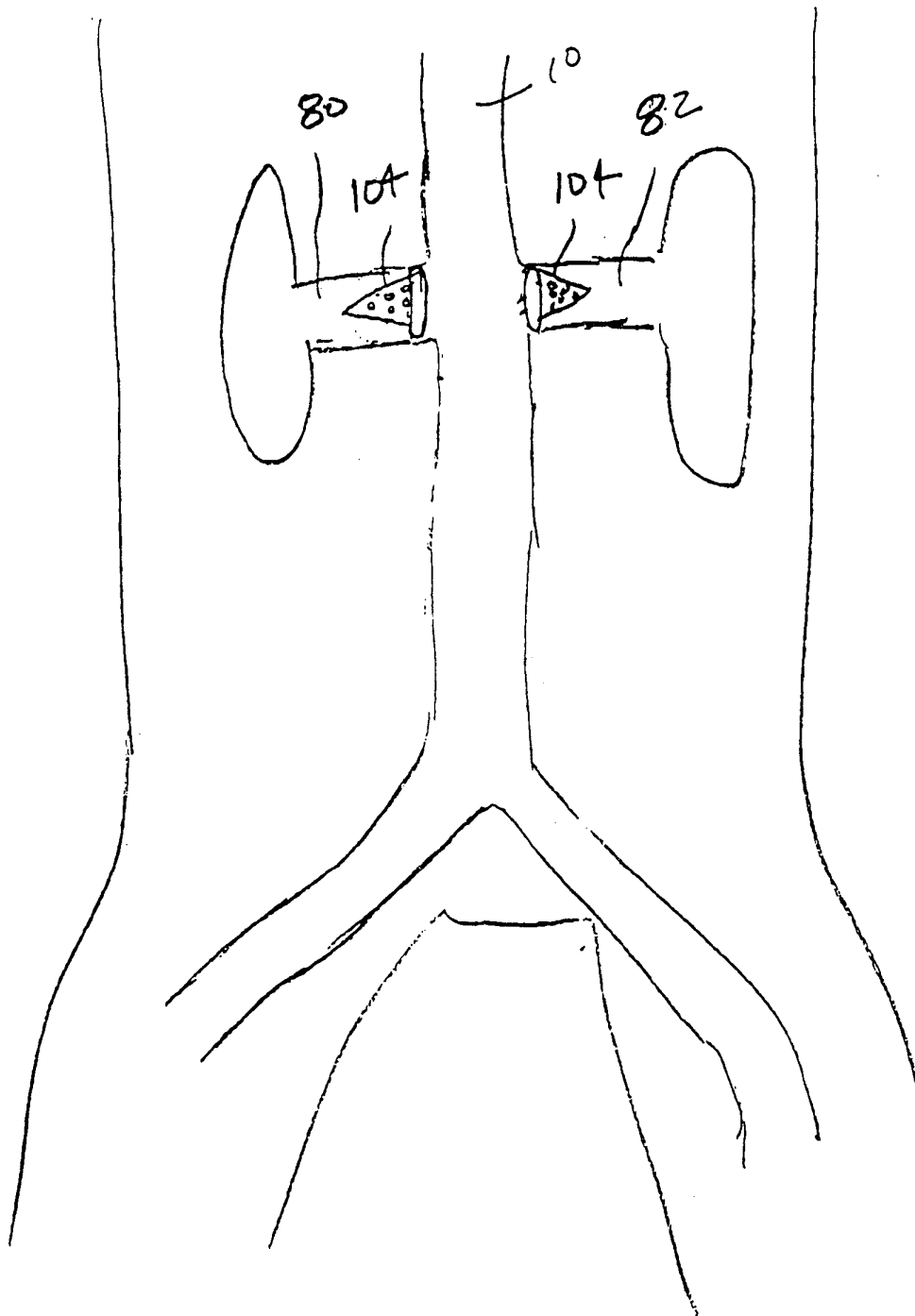

FIG. 24

FIG. 25



CEREBRAL BLOOD FLOW CHANGES IN PENUMBRA AND IN NORMAL HEMISPHERE

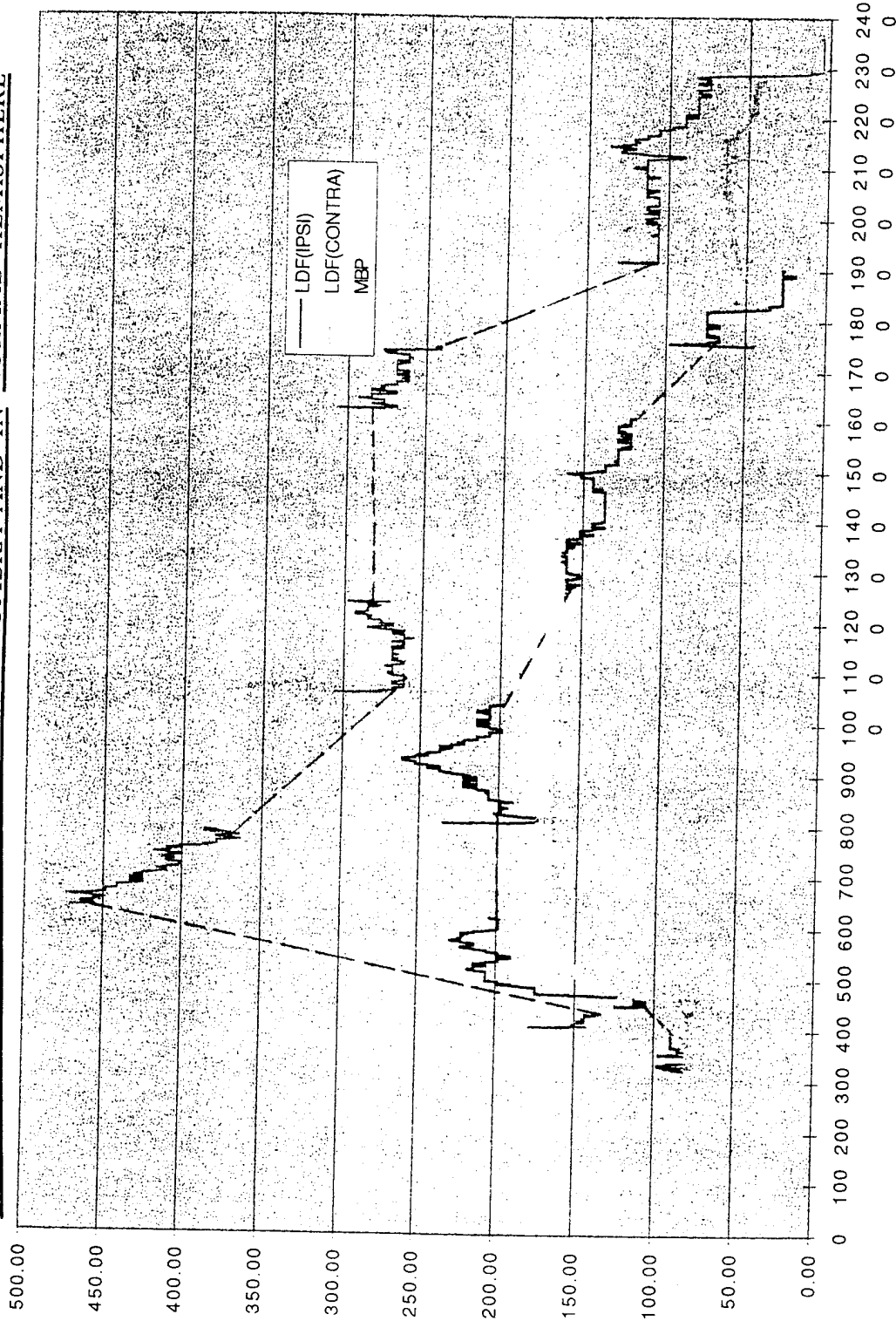

FIG. 26

CAPILLARY PERFUSION IN NORMAL RAT BRAIN

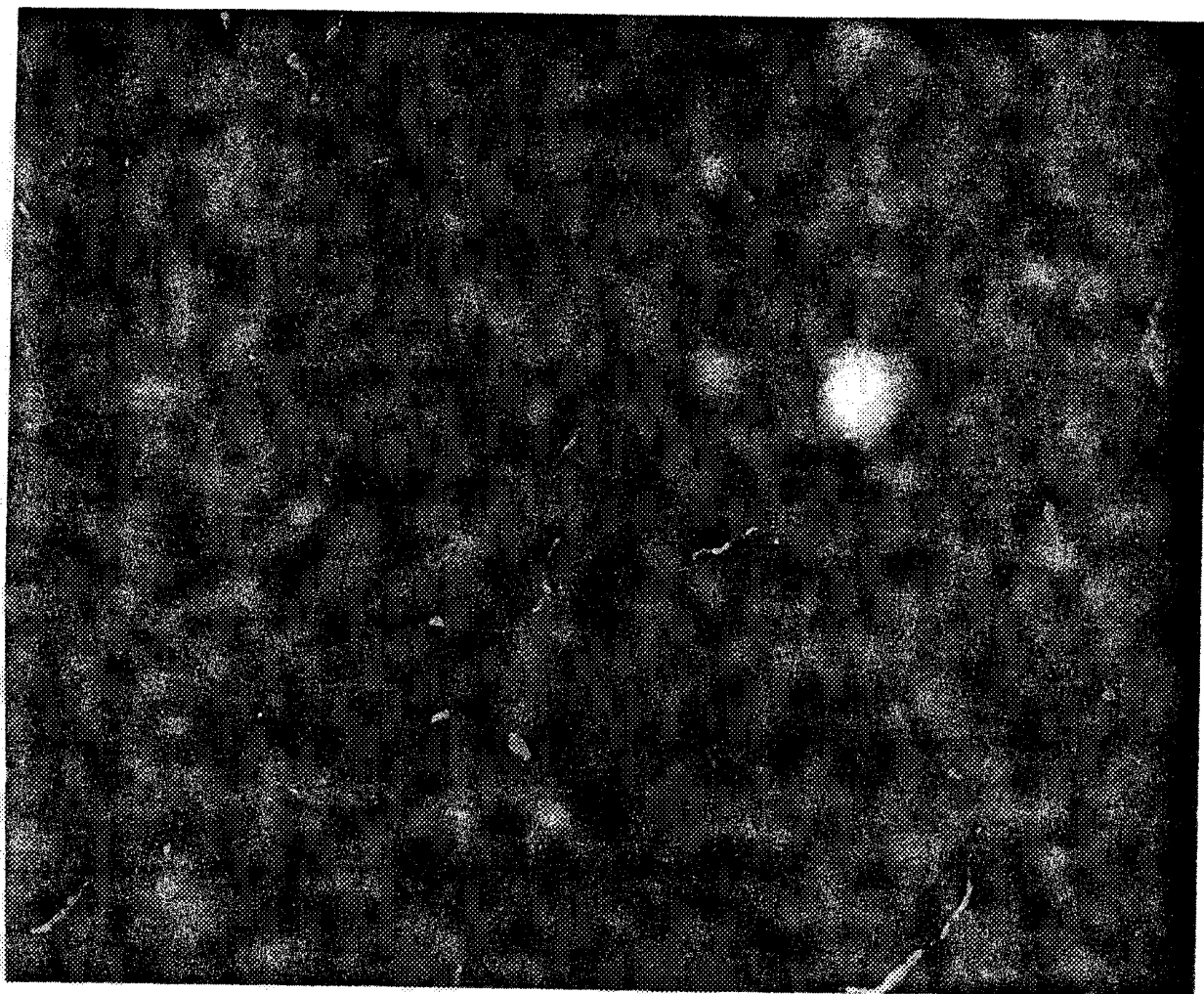

FIG. 27

CAPILLARIES IN CORE WITHOUT AORTIC LIGATION

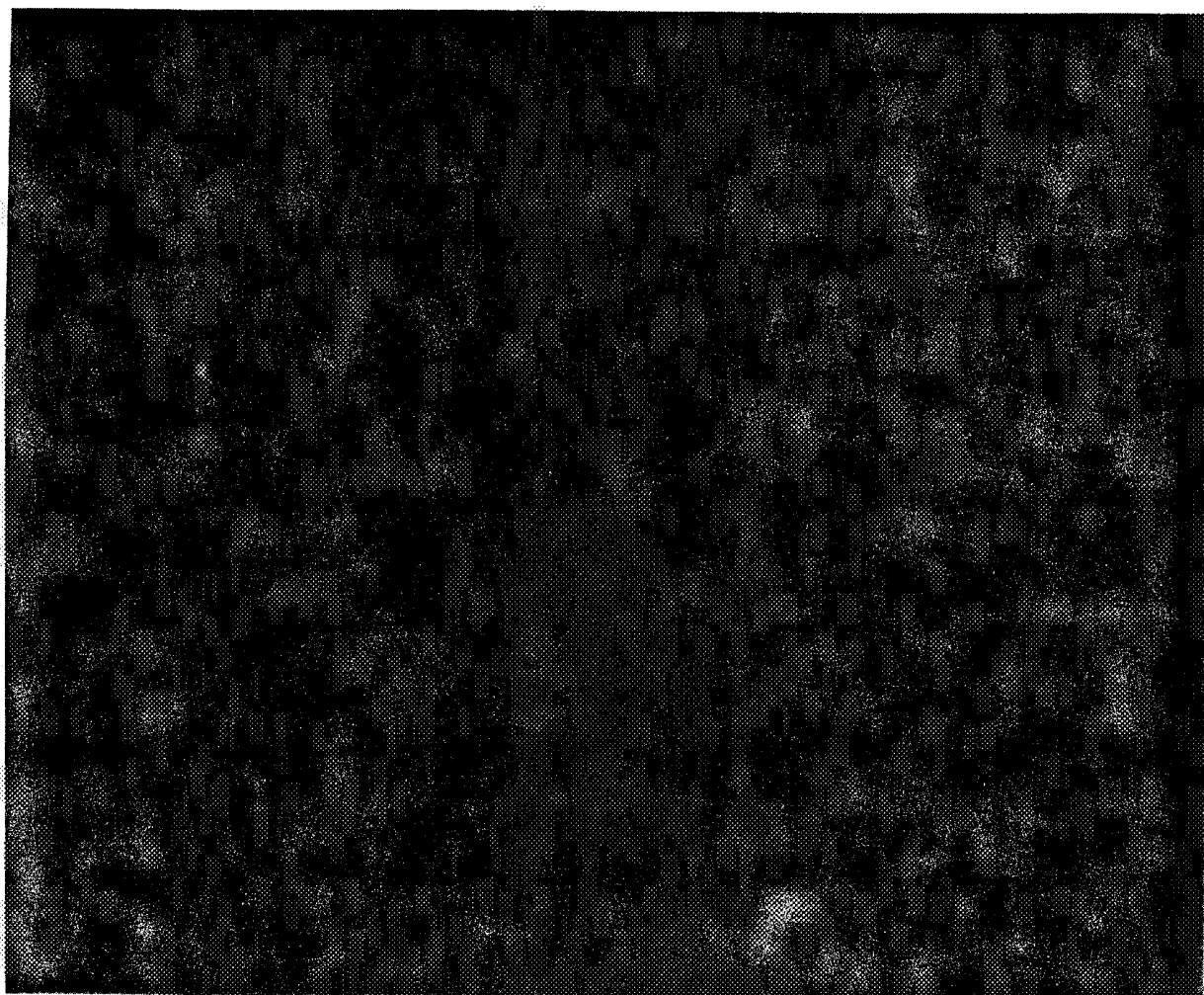

FIG. 28

CAPILLARIES IN PENUMBRA WITHOUT AORTIC LIGATION

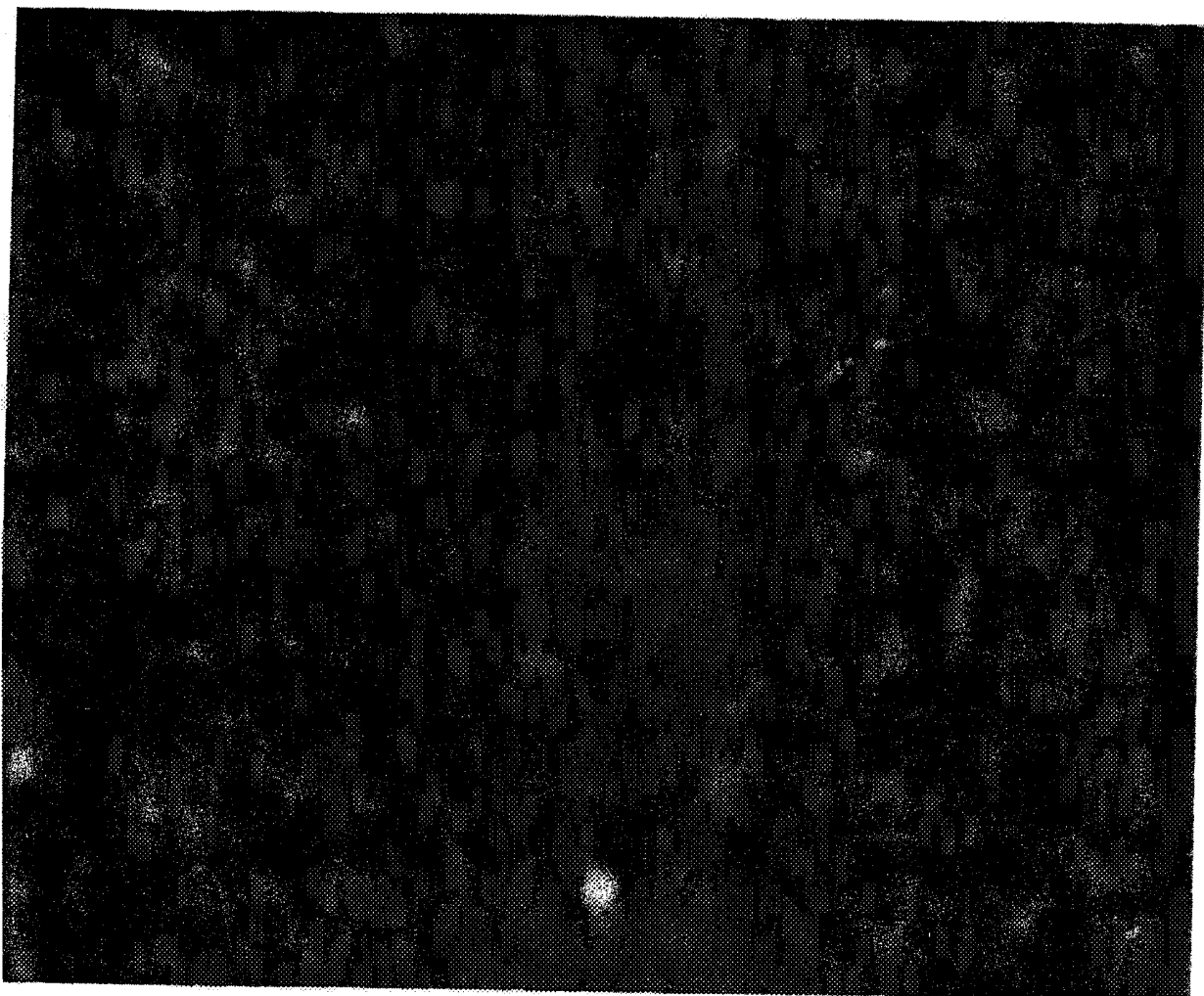

FIG. 29

CAPILLARIES IN CORE WITH AORTIC LIGATION



FIG. 30

CAPILLARIES IN PENUMBRA WITH AORTIC LIGATION

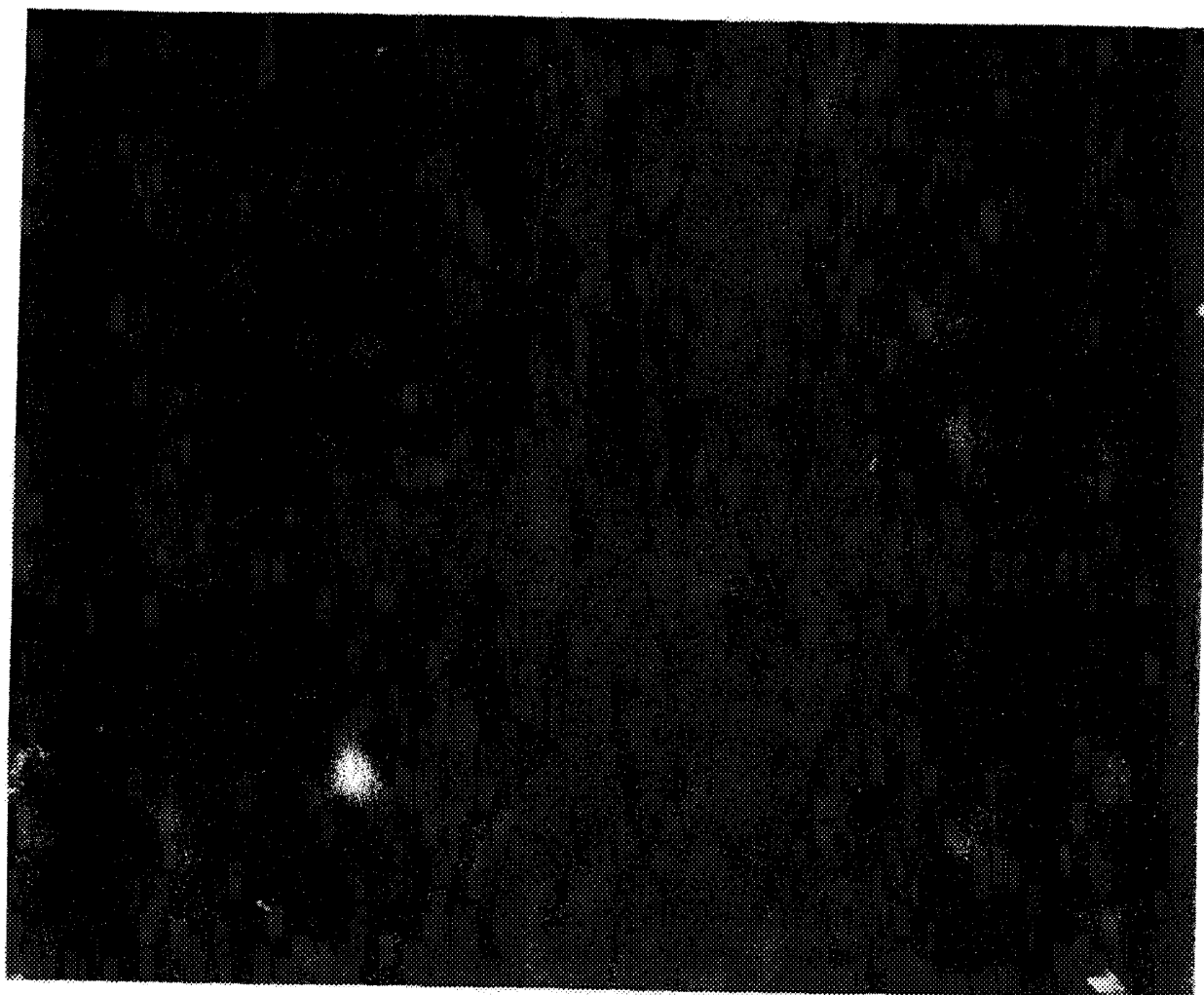

FIG. 31

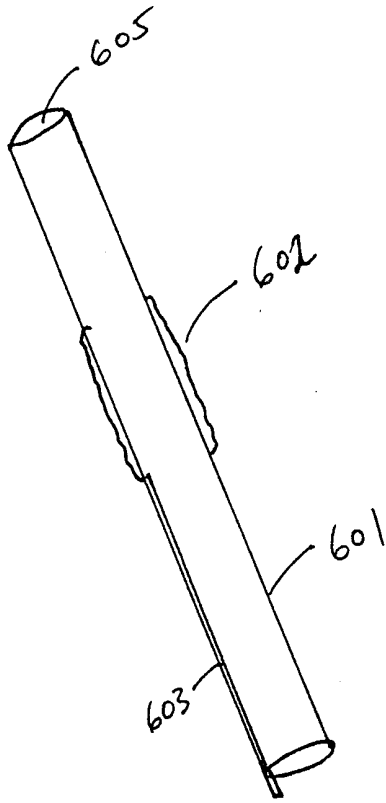

FIG. 32A

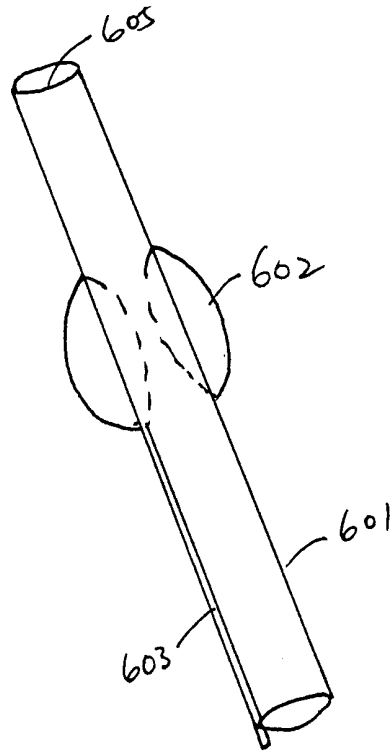

FIG. 32B

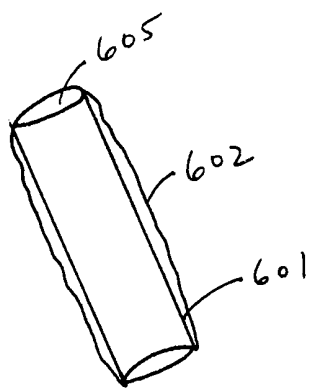

FIG. 32C

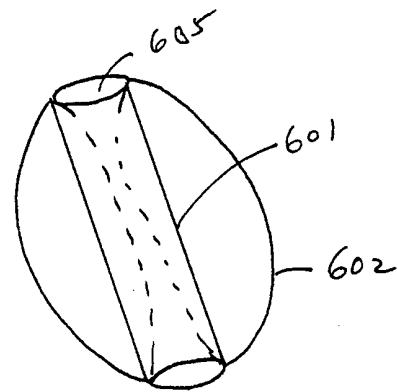

FIG. 32D

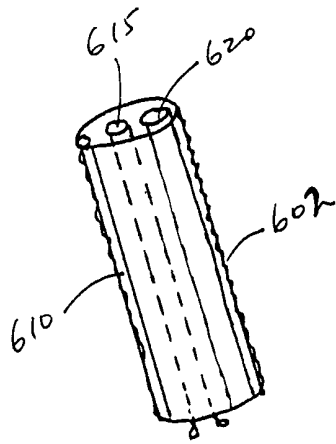

FIG. 32E

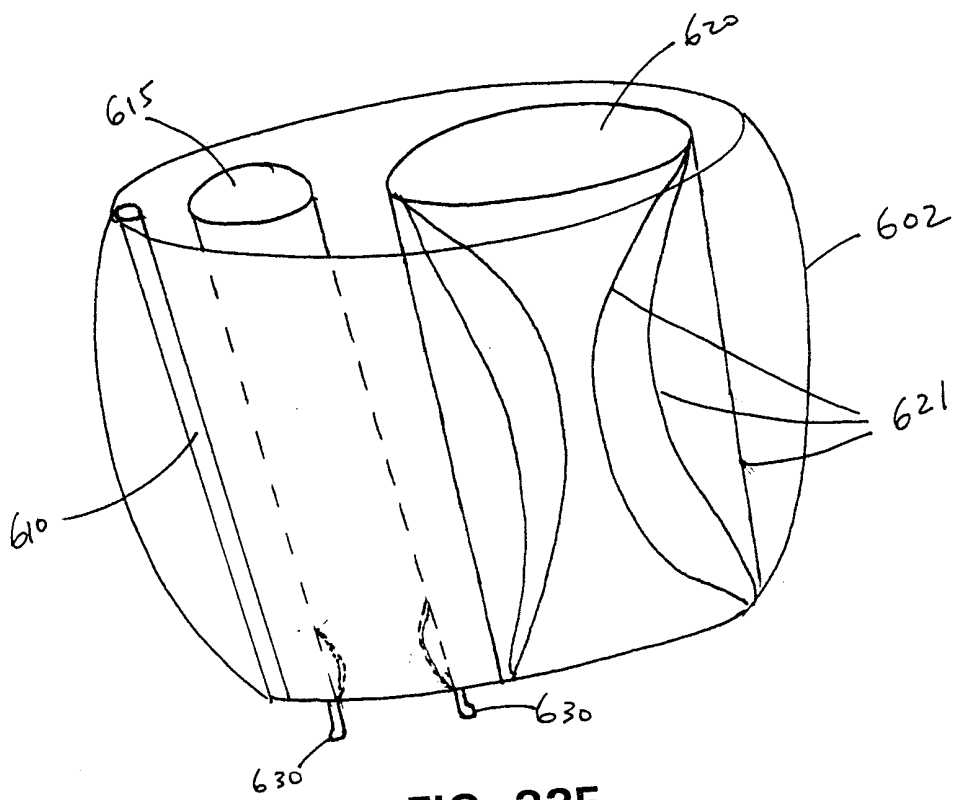

FIG. 32F

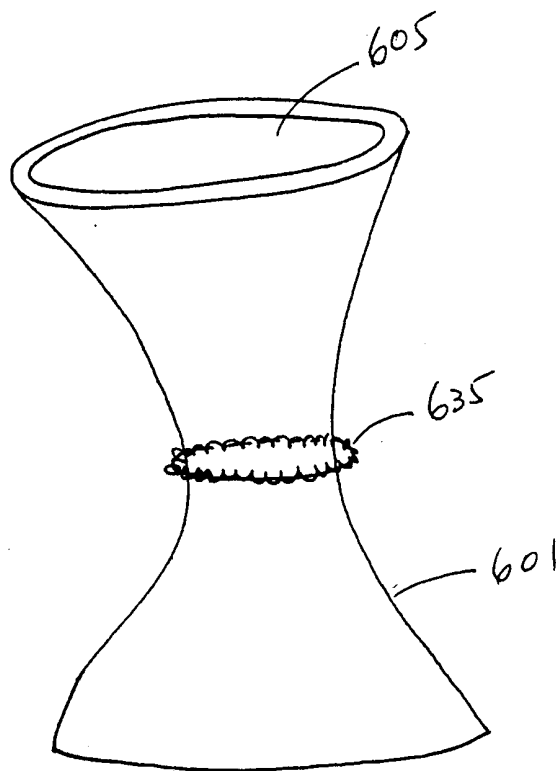

FIG. 32G

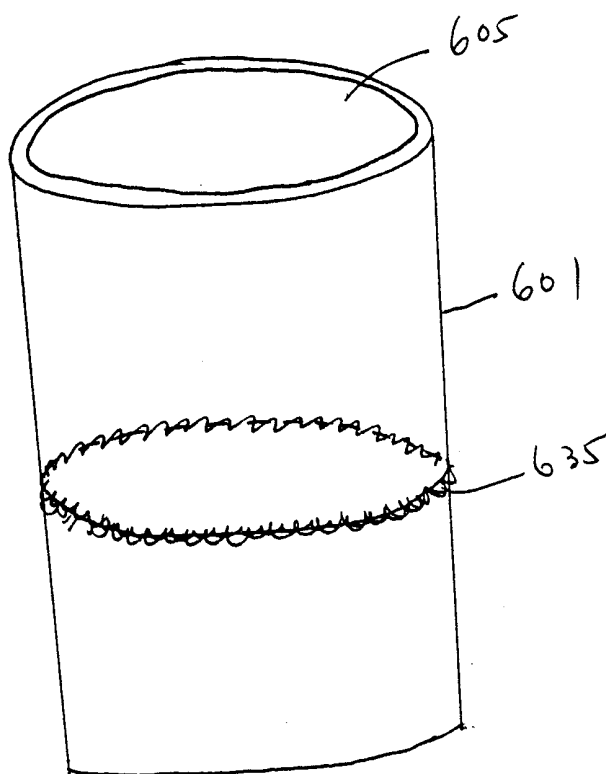

FIG. 32H

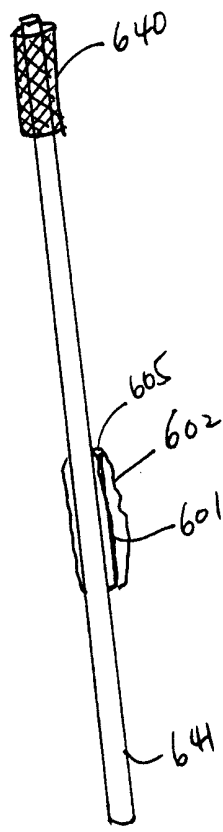

FIG. 33A

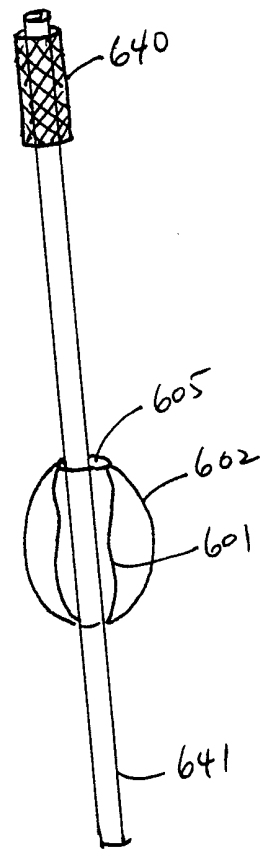

FIG. 33B

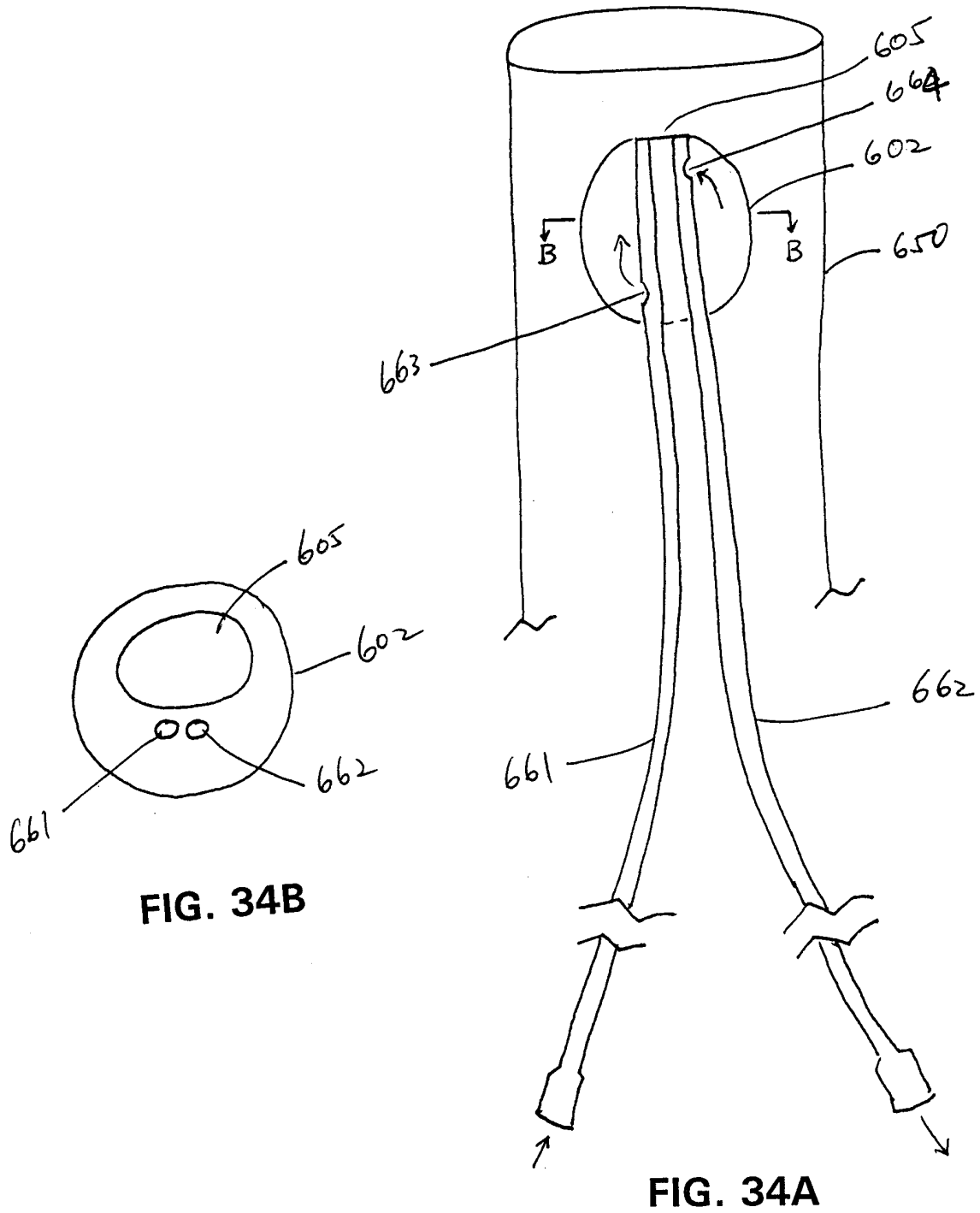

FIG. 34B

FIG. 34A

INTERNATIONAL SEARCH REPORT

International application No.
PCT/US00/05005

A. CLASSIFICATION OF SUBJECT MATTER IPC(7) : A61M 31/00 US CL : 604/507 According to International Patent Classification (IPC) or to both national classification and IPC		
B. FIELDS SEARCHED Minimum documentation searched (classification system followed by classification symbols) U.S. : 604/507; 606/200 Documentation searched other than minimum documentation to the extent that such documents are included in the fields searched Electronic data base consulted during the international search (name of data base and, where practicable, search terms used) BRS		
C. DOCUMENTS CONSIDERED TO BE RELEVANT		
Category*	Citation of document, with indication, where appropriate, of the relevant passages	Relevant to claim No.
A	US 5,662,671 A (BARBUT et al.) 02 September 1997, entire patent.	1-170
A	US 4,798,588 A (AILLON) 17 January 1989, col. 4, and figures.	1-170
A	US 5,824,034 A (SCHMITT et al.) 20 October 1998, entire patent.	1-170
A	US 4,601,706 A (AILLON) 22 July 1986, entire patent.	1-170
A	US 6,010,522 A (BARBUT et al.) 04 January 2000, entire patent.	1-170
A	US 5,290,247 A (CRITTENDEN) 01 March 1994, entire patent.	1-170
<input type="checkbox"/> Further documents are listed in the continuation of Box C. <input type="checkbox"/> See patent family annex.		
* "A" "E" "L" "O" "P"	Special categories of cited documents: document defining the general state of the art which is not considered to be of particular relevance earlier document published on or after the international filing date document which may throw doubts on priority claim(s) or which is cited to establish the publication date of another citation or other special reason (as specified) document referring to an oral disclosure, use, exhibition or other means document published prior to the international filing date but later than the priority date claimed	"T" "X" "Y" "&" later document published after the international filing date or priority date and not in conflict with the application but cited to understand the principle or theory underlying the invention document of particular relevance; the claimed invention cannot be considered novel or cannot be considered to involve an inventive step when the document is taken alone document of particular relevance; the claimed invention cannot be considered to involve an inventive step when the document is combined with one or more other such documents, such combination being obvious to a person skilled in the art document member of the same patent family
Date of the actual completion of the international search 31 MAY 2000	Date of mailing of the international search report 21 JUN 2000	
Name and mailing address of the ISA/US Commissioner of Patents and Trademarks Box PCT Washington, D.C. 20231 Facsimile No. (703) 305-3230	Authorized officer MICHAEL THOMPSON Telephone No. (703) 305-1619	