



(19) **United States**

(12) **Patent Application Publication**  
Fortino et al.

(10) **Pub. No.: US 2003/0197146 A1**

(43) **Pub. Date: Oct. 23, 2003**

(54) **VALVE CLOSURE SYSTEM AND VALVE CLOSURE ASSEMBLY**

**Publication Classification**

(75) Inventors: **Richard D. Fortino**, Alma, MI (US);  
**David N. Maniez JR.**, St. Louis, MI (US)

(51) **Int. Cl.<sup>7</sup>** ..... **F16K 31/00**  
(52) **U.S. Cl.** ..... **251/291; 251/293**

Correspondence Address:  
**George L. Boller**  
**Suite 316**  
**17199 North Laurel Park Drive**  
**Livonia, MI 48152 (US)**

(57) **ABSTRACT**

(73) Assignee: **Powell Fabrication & manufacturing, Inc.**

A valve closure assembly (50) for remotely and automatically closing a railway tank car valve (V1, V2, V3, V4), characterized by improved convenience in mounting on a tank car dome (160) and adaptability to various dome geometries, valve configurations, and car-to-car dimensional variations. A clamp assembly (52) mounts assembly (50) on dome (160). An adapter (180) operated by a motor (58) turns a valve handle (A1, A2, A3, A4) when motor (58) runs. A positioning mechanism (54) selectively positions adapter (180) relative to clamp assembly (52) to establish a spatial relationship between them for enabling clamp assembly (52) to be placed at a desired location on the dome wall (162) and adapter (180) to engage a valve handle. Positioning mechanism (54) comprises three degrees of freedom of motion for establishing the spatial relationship of adapter (180) to clamp assembly (52), two of which are in the horizontal plane.

(21) Appl. No.: **10/418,693**

(22) Filed: **Apr. 18, 2003**

**Related U.S. Application Data**

(60) Provisional application No. 60/374,652, filed on Apr. 22, 2002.

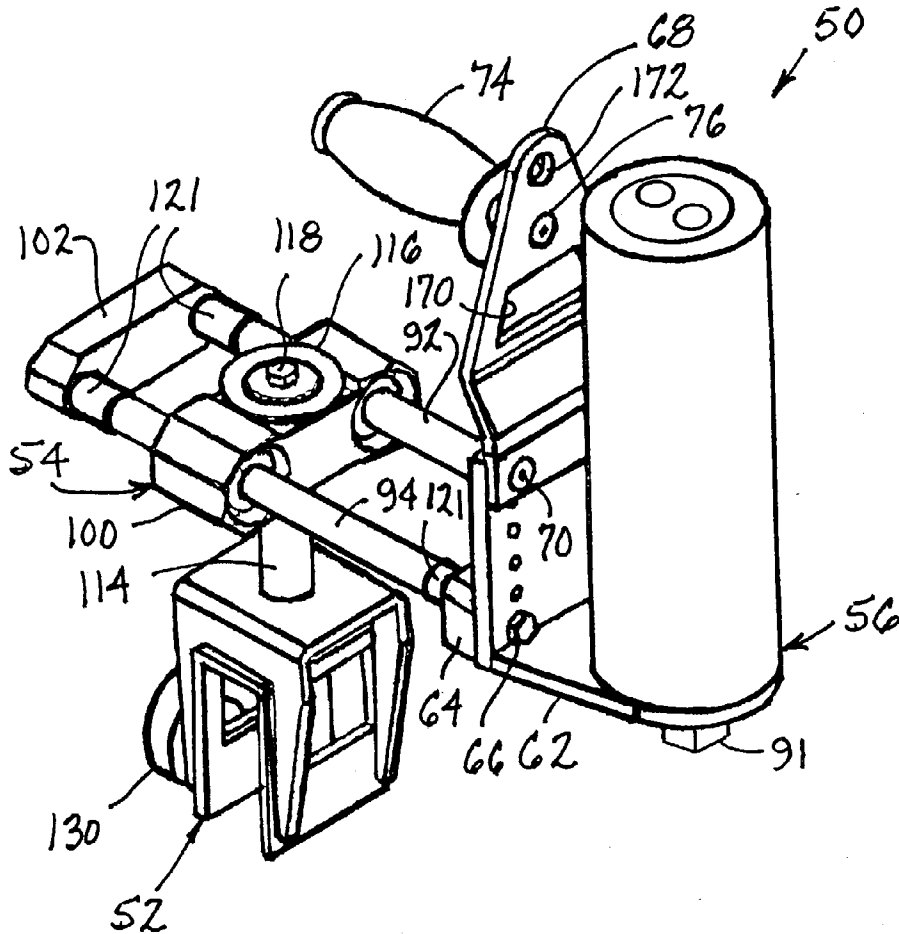

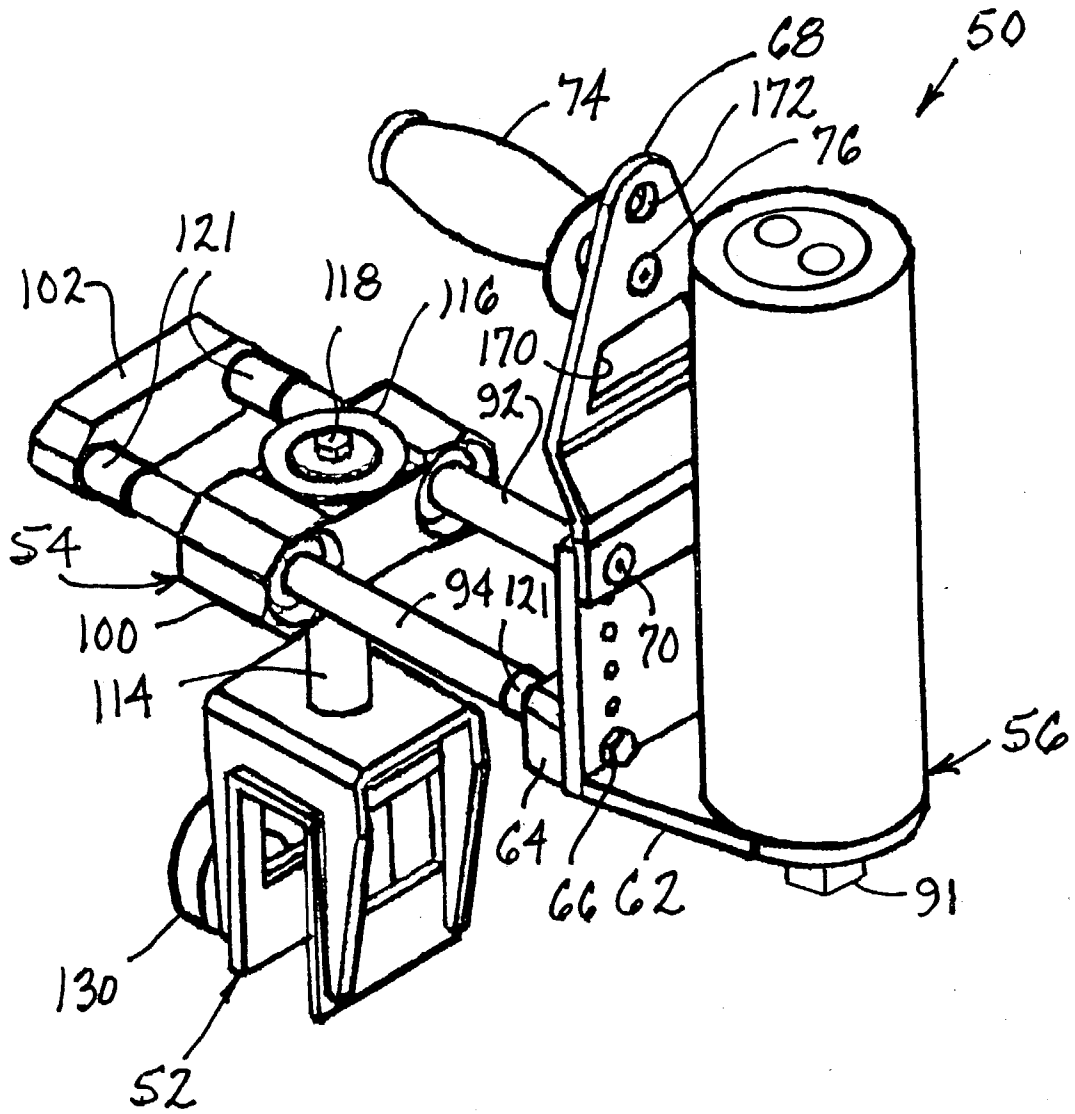

Figure 1

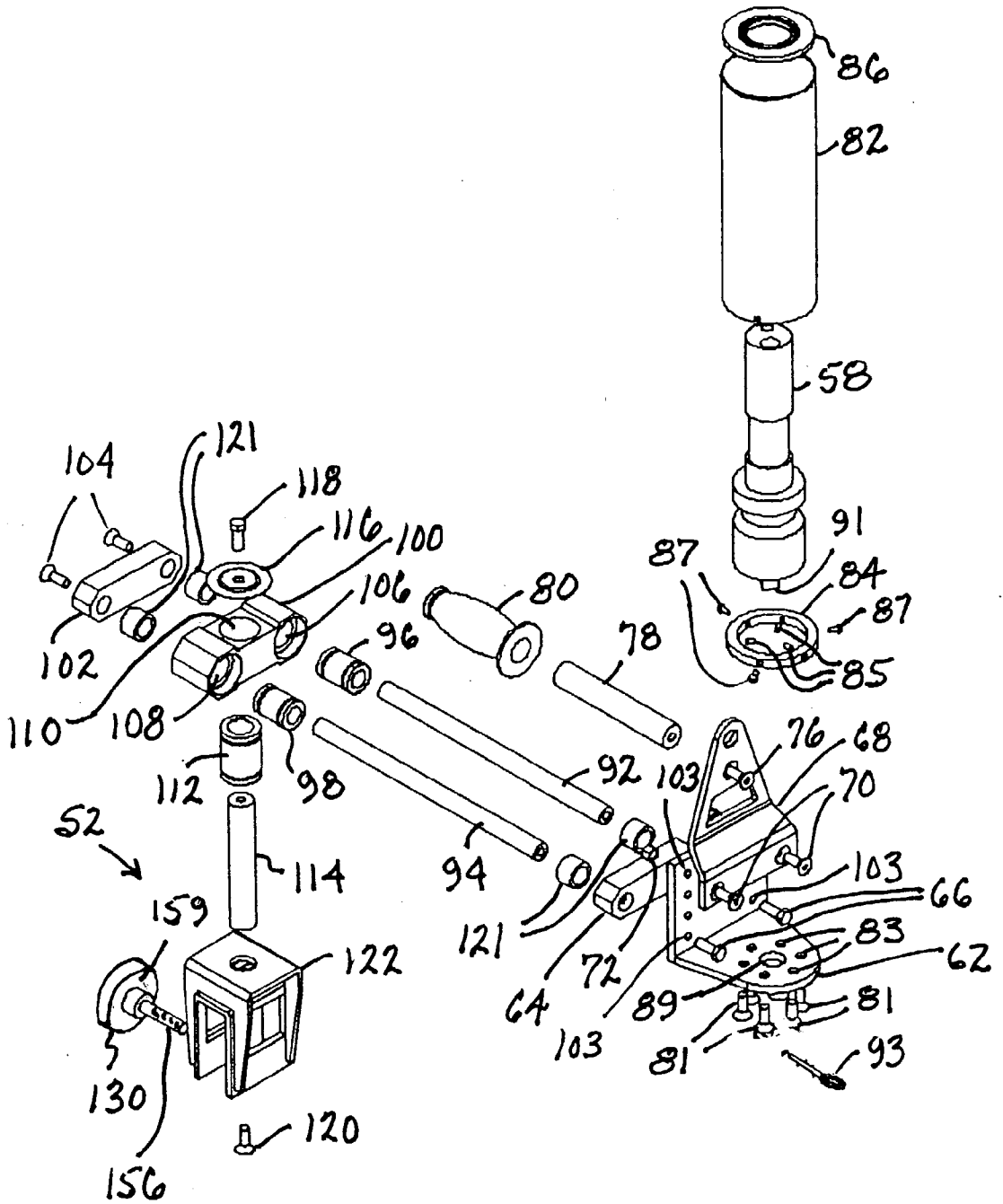

Figure 2

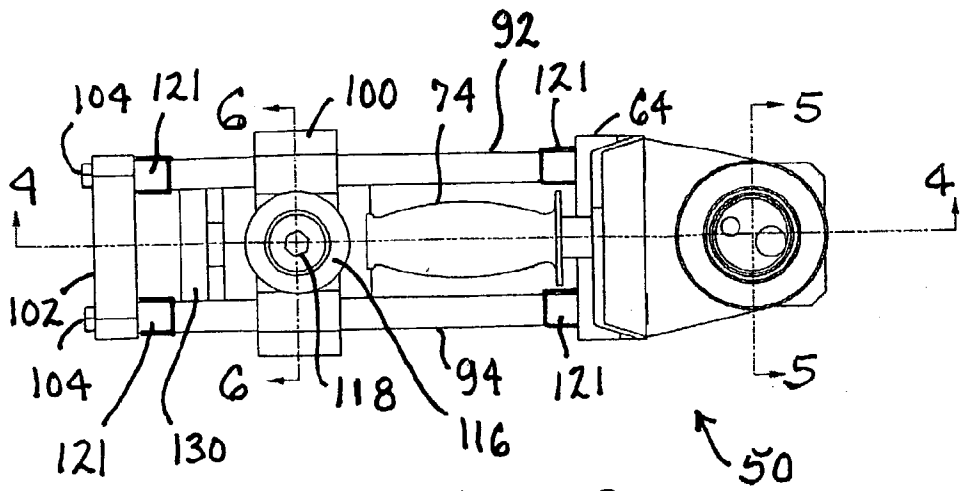

Figure 3

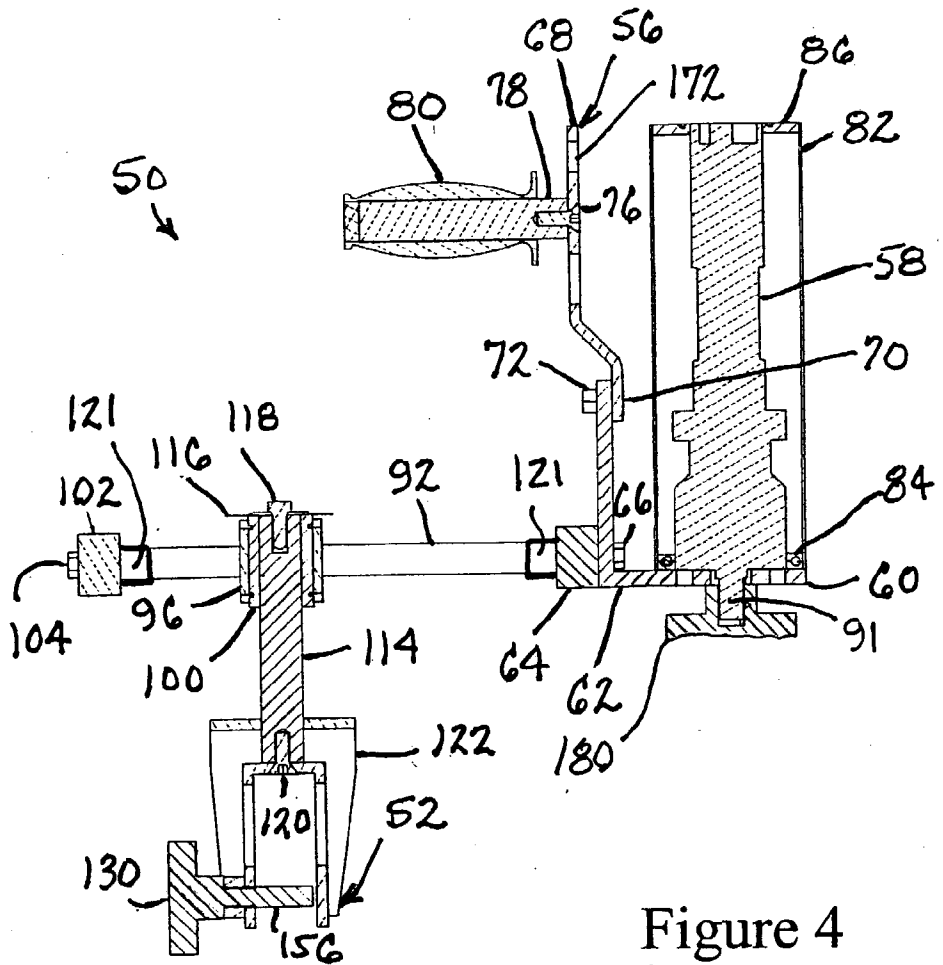

Figure 4

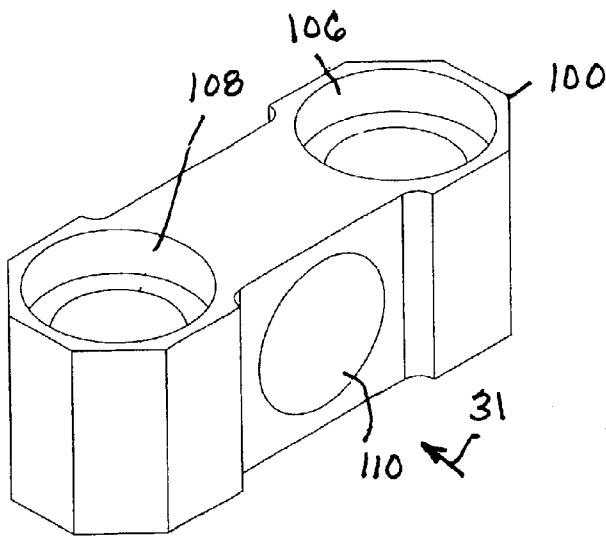

Figure 30

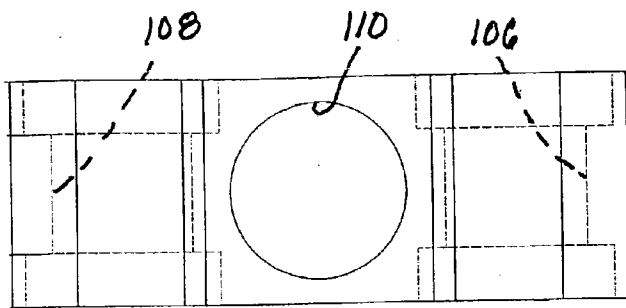

Figure 31

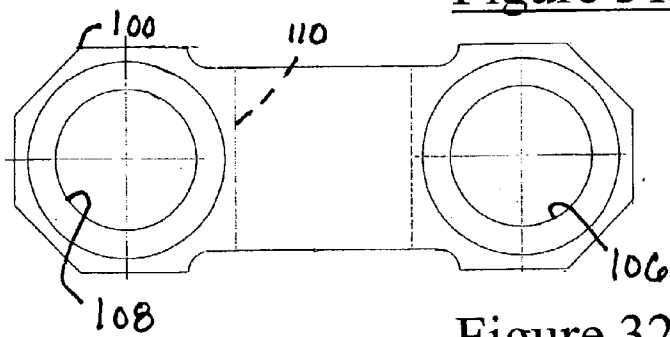

Figure 32

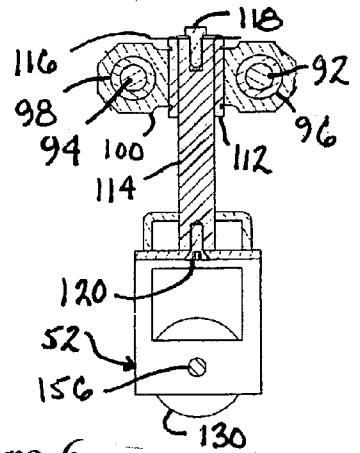

Figure 6

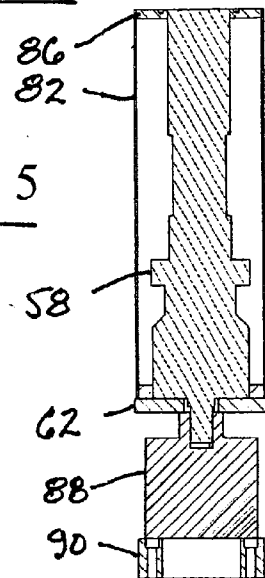

Figure 5

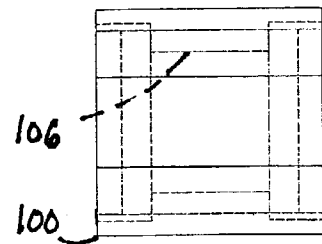

Figure 33

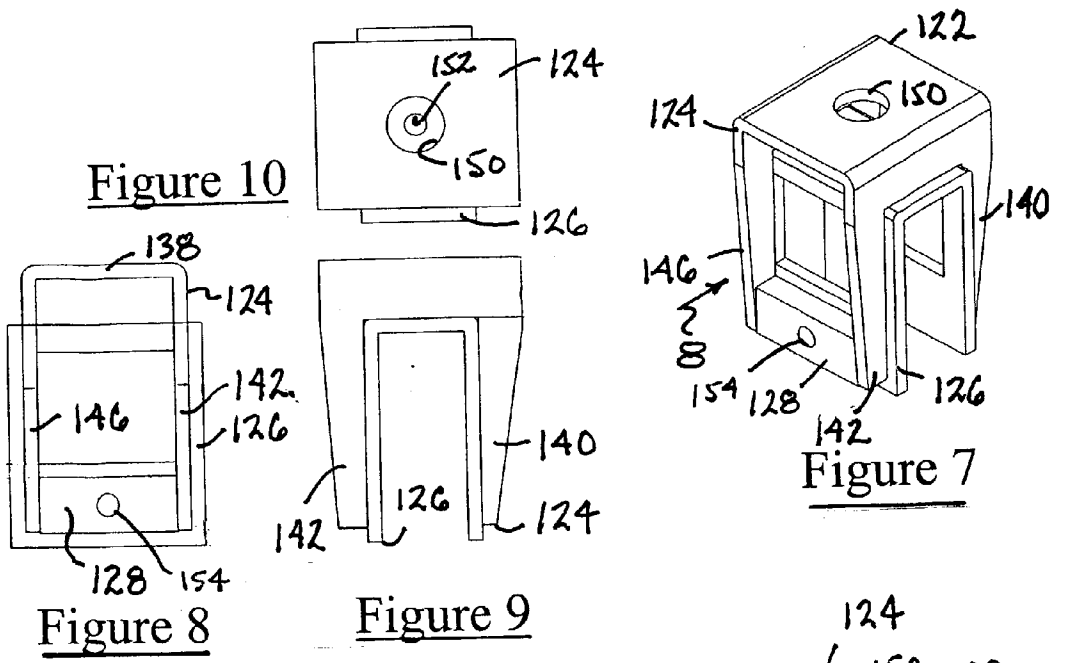

Figure 10

Figure 7

Figure 8

Figure 9

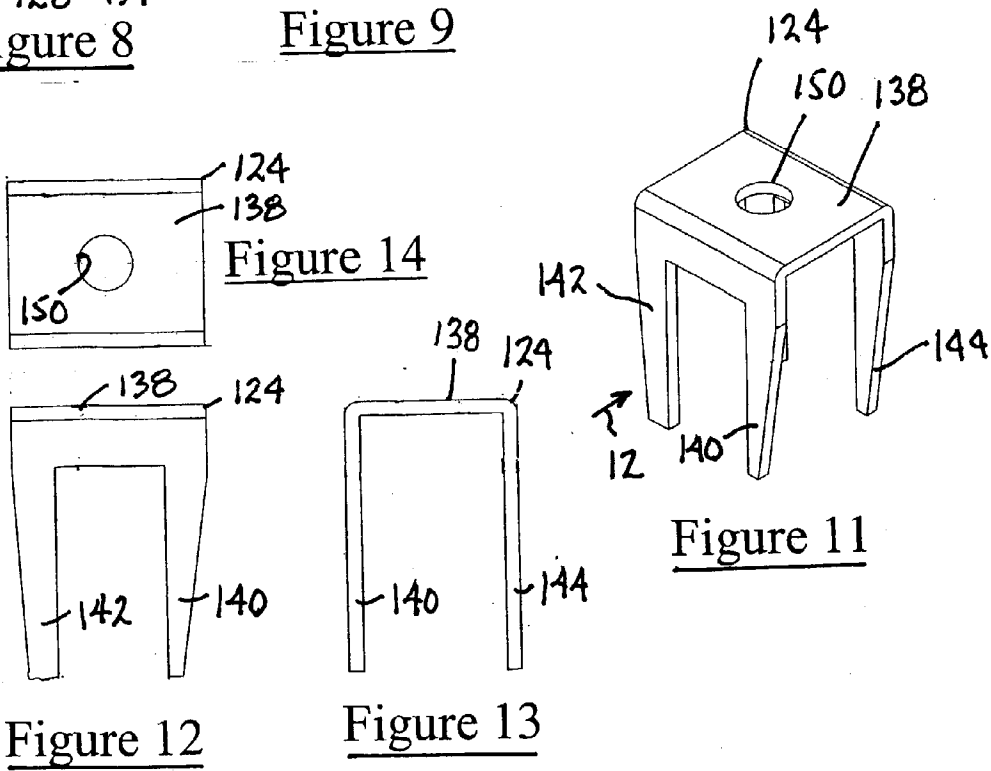

Figure 14

Figure 11

Figure 12

Figure 13

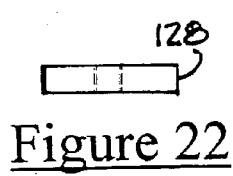
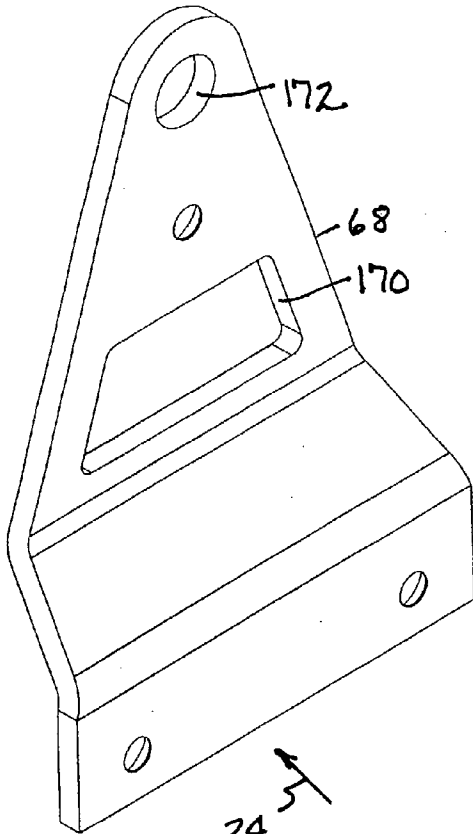

Figure 22

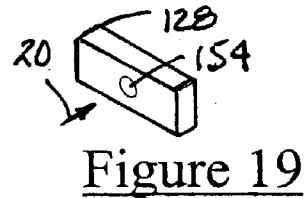

Figure 19



Figure 20

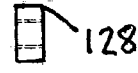

Figure 21

Figure 23

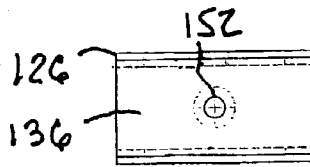
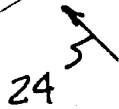

Figure 18

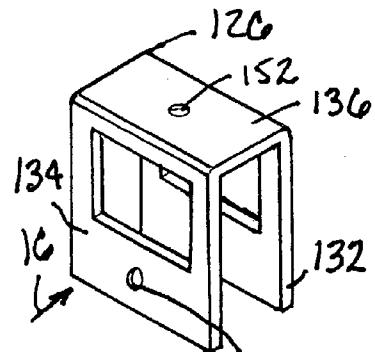

Figure 15

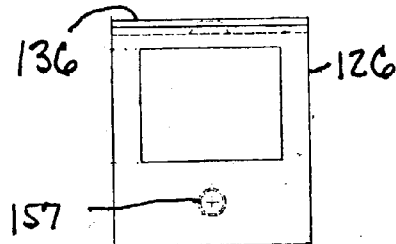

Figure 16

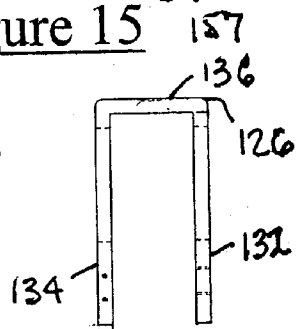

Figure 17

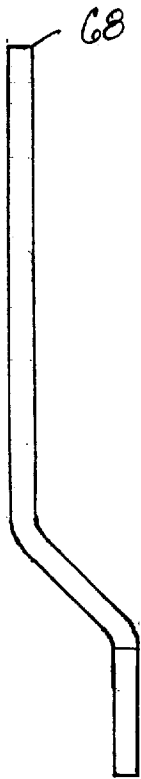

Figure 25

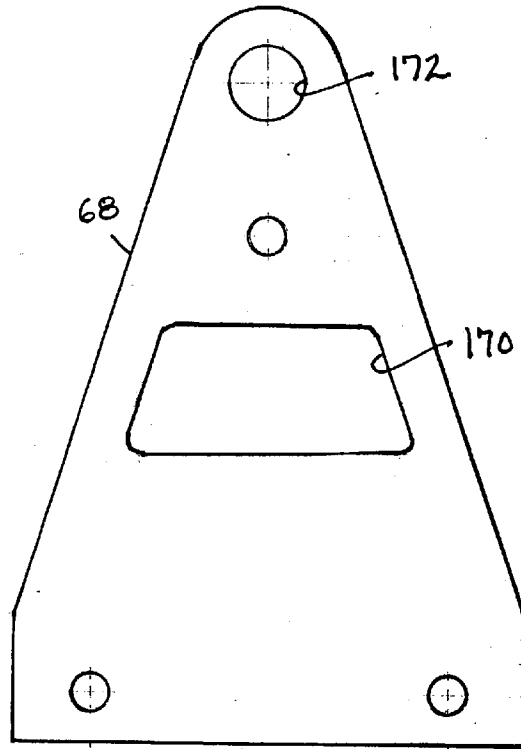

Figure 24



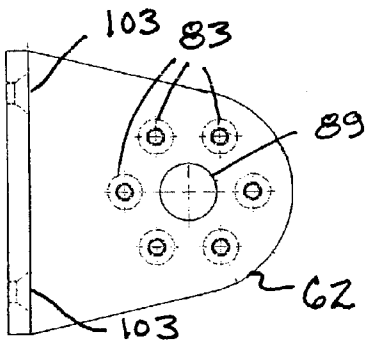

Figure 28

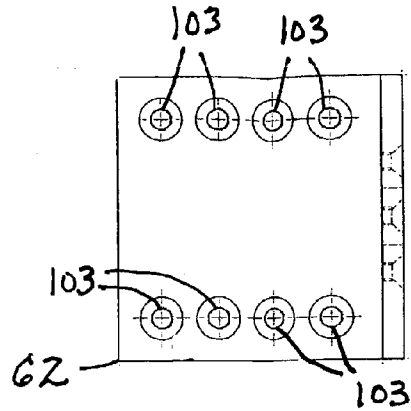

Figure 29

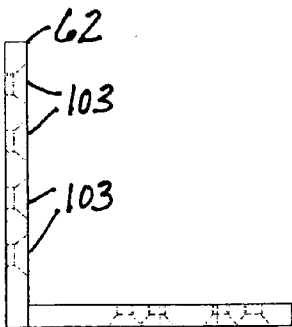

Figure 27

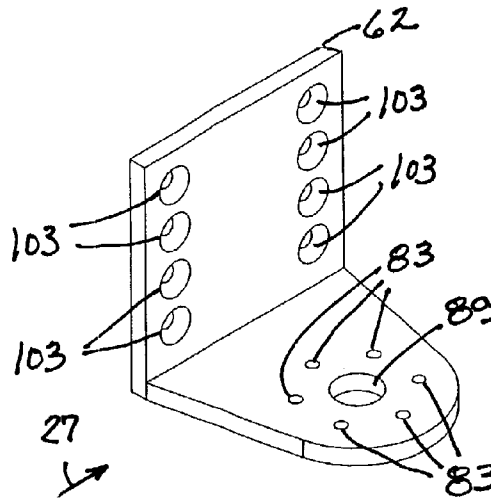

Figure 26

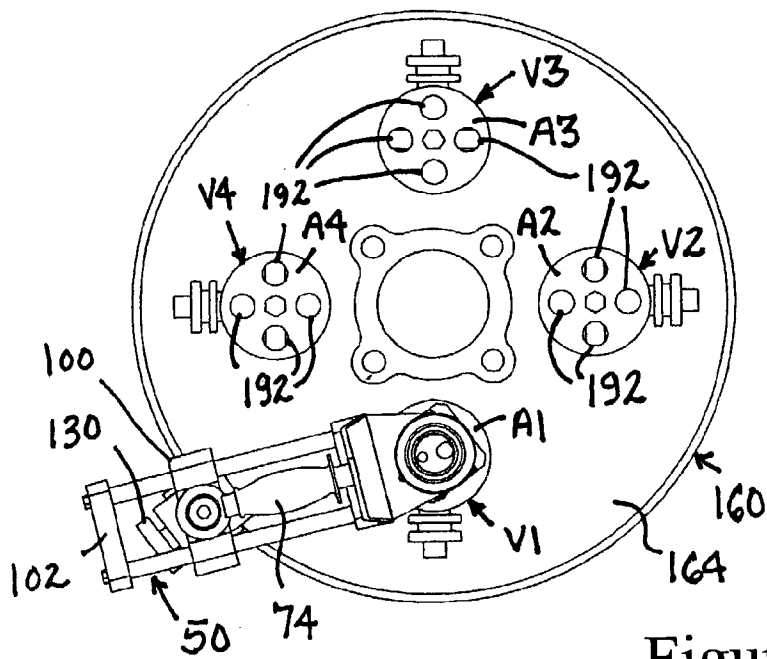

Figure 34

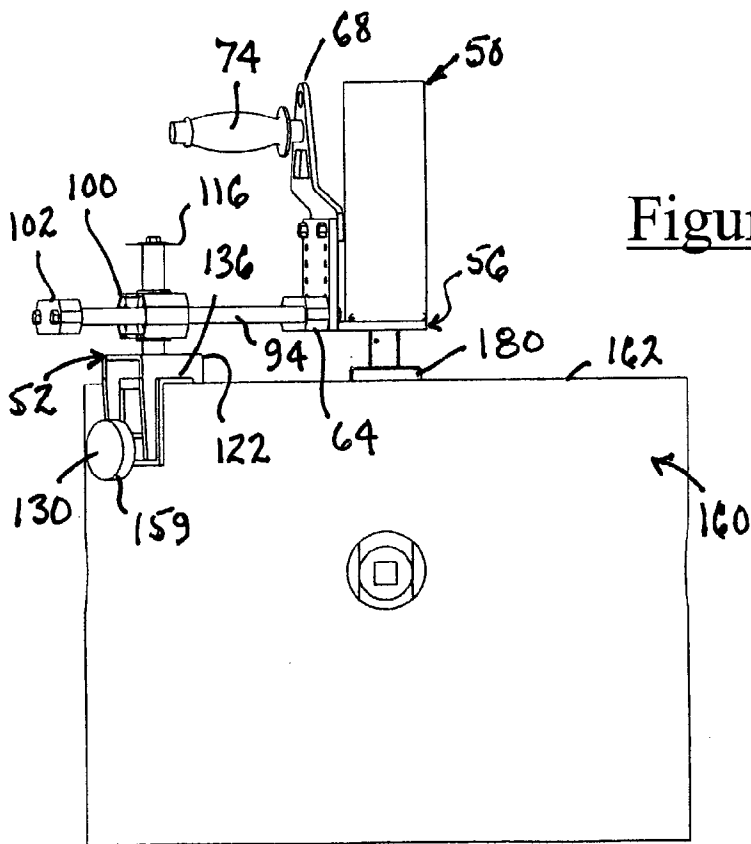

Figure 35

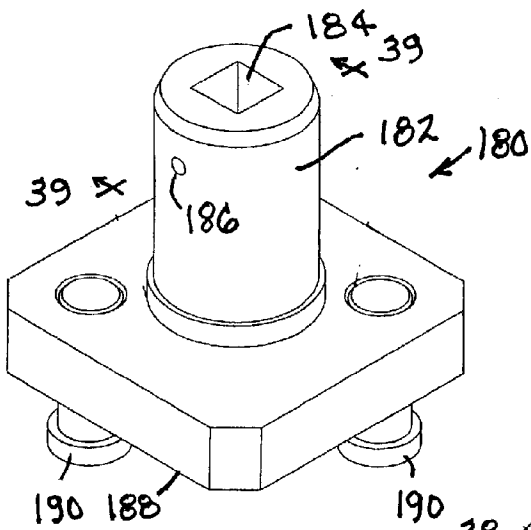

Figure 36

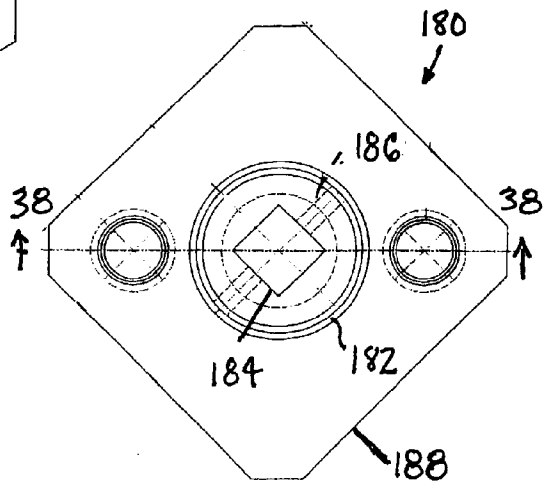

Figure 37

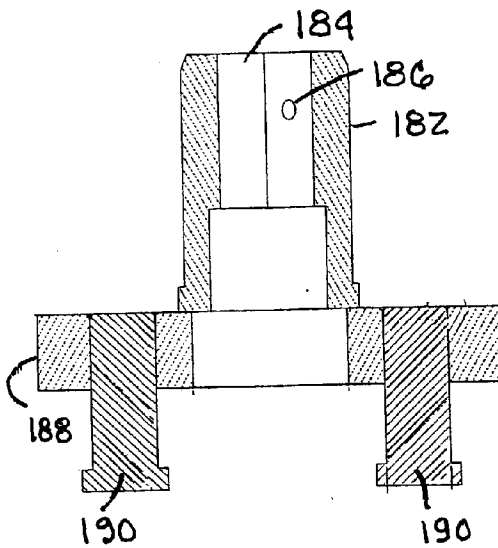

Figure 38

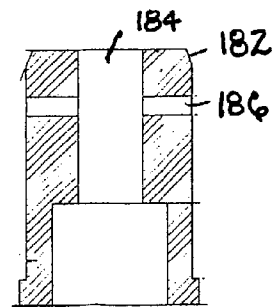

Figure 39

## VALVE CLOSURE SYSTEM AND VALVE CLOSURE ASSEMBLY

### REFERENCE TO RELATED APPLICATION AND PRIORITY CLAIM

[0001] This application derives from the following commonly owned co-pending patent application, the priority of which is expressly claimed: Provisional Application No. 60/374,652, filed on Apr. 22, 2002 in the names of Richard Fortino and David N. Maniez Jr.

### FIELD OF THE INVENTION

[0002] This invention relates to a valve closure system and valve closure assembly for promptly and automatically closing tank valves, especially tank valves of railway tank cars. The invention also relates to methods of making and using the valve closure assembly.

### BACKGROUND OF THE INVENTION

[0003] Various fluids are transported by railway tank cars. Such tank cars have domes where various valves are located. The portions of the valves that are external to the tank, including the valve handles are housed within a protective housing that has a hinged lid or cover that is opened to expose the handles. One or more of the valves is opened during certain procedures involving loading and/or unloading fluid into and/or from the tank. During such procedures, a valve closure assembly having a power actuator is hoisted onto the dome and mounted there. The power actuator is fitted to the handle of the open valve and can be remotely and automatically operated to close the open valve when conditions call for valve closing.

### SUMMARY OF THE INVENTION

[0004] The present invention relates to improvements in valve closure assemblies for remotely and automatically closing an open tank car valve when conditions call for valve closing. The inventive valve closure assembly is characterized by improved convenience in mounting and use on a railway tank car and by better adaptability to various types of protective housings and various tank car valve configurations within the housings. It is tolerant of car-to-car variations in standard dimensions that are promulgated by industry for various valve configurations. The inventive principles include methods of making and using the valve closure assembly, and certain aspects of the invention may be useful in other than the context of a railway tank car.

[0005] One generic aspect of the invention relates to an assembly for turning an external handle of a tank dome valve about a vertical axis. The assembly comprises a mounting for removably mounting the assembly on a tank dome and an adapter operated by a motor for engaging the valve handle and turning the handle when the motor operates. The assembly further comprises a positioning mechanism for selectively positioning the adapter relative to the mounting to establish a spatial relationship of each to the other for enabling the mounting to be placed at a desired location on the dome and the adapter to engage the valve handle. The positioning mechanism comprises two degrees of freedom of motion in a horizontal plane for establishing the spatial relationship of the adapter to the mounting in the horizontal plane.

[0006] Another generic aspect of the invention relates to an assembly for turning an external handle of a tank dome valve about a vertical axis where the assembly comprises a mounting for removably mounting the assembly on a tank dome, an adapter operated by a motor for engaging the valve handle and turning the handle when the motor operates, and a positioning mechanism for selectively positioning the adapter relative to the mounting to establish a spatial relationship of each to the other for enabling the mounting to be placed at a desired location on the dome and the adapter to engage the valve handle. The positioning mechanism comprises three degrees of freedom of motion for establishing the spatial relationship of the adapter to the mounting.

[0007] Another generic aspect of the invention relates to a method of associating a valve operating assembly with a fluid-containing tank for enabling an adapter that is operated by a motor of the valve operating assembly to turn an external handle of a valve on the tank about an axis of turning while a mounting of the assembly is supporting the assembly on the tank. The method comprises relatively positioning the mounting and the adapter via a positioning mechanism of the valve operating assembly that has two degrees of freedom of motion in a plane of reference that is perpendicular to the axis of turning to establish a spatial relationship of the mounting and motor to each other in the plane of reference for placing the adapter in engagement with the valve handle and placing the mounting at a desired location on the tank.

[0008] Another generic aspect of the invention relates to a method of associating a valve operating assembly with a fluid-containing tank for enabling an adapter operated by a motor of the valve operating assembly to turn a valve on the tank about an axis of turning while a mounting of the assembly is supporting the assembly on the tank wherein the method comprises relatively positioning the mounting and the adapter via a positioning mechanism of the valve operating assembly that has three degrees of freedom of motion to establish a spatial relationship of the mounting and motor to each other for placing the adapter in engagement with the valve handle and placing the mounting at a desired location on the tank.

[0009] Still another generic aspect of the invention relates to a method of associating a valve operating assembly comprising a mounting, a positioning mechanism, and an adapter operated by a motor with a dome of a fluid-containing tank comprising a valve having a handle that is external to the tank and an upright wall spaced horizontally from the valve handle for enabling the adapter to engage the valve handle and turn the handle about an axis of turning while the mounting is supporting the assembly at a desired location on the dome in horizontally spaced relation to the valve handle. The method comprises disposing the valve operating assembly vertically over the dome, lowering the assembly onto the dome, and causing the positioning mechanism to relatively position the mounting and the adapter to place the adapter in engagement with the valve handle and to place the mounting at a desired location on the upright wall.

[0010] The foregoing features, advantages, and aspects of the invention, along with additional ones, will be seen in the ensuing description and claims, which are accompanied by drawings. The drawings disclose a presently preferred

embodiment of the invention according to the best mode contemplated at this time for carrying out the invention.

#### BRIEF DESCRIPTION OF THE DRAWINGS

- [0011] FIG. 1 is a perspective view showing a presently preferred embodiment of valve closure system comprising a valve closure assembly according to the present invention.
- [0012] FIG. 2 is an exploded perspective view of FIG. 1.
- [0013] FIG. 3 is a top of plan view of FIG. 1.
- [0014] FIG. 4 is a vertical cross section view in the direction of arrows 4-4 in FIG. 3.
- [0015] FIG. 5 is a vertical cross section view in the direction of arrows 5-5 in FIG. 3.
- [0016] FIG. 6 is a vertical cross section view in the direction of arrows 6-6 in FIG. 3.
- [0017] FIG. 7 is a perspective view of a clamp assembly of the valve closure assembly.
- [0018] FIG. 8 is an elevation view in the direction of arrow 8 in FIG. 7.
- [0019] FIG. 9 is a right side elevation view of FIG. 8.
- [0020] FIG. 10 is a top view of FIG. 9.
- [0021] FIG. 11 is a perspective view of one element of the clamp assembly by itself.
- [0022] FIG. 12 is an elevation view in the direction of arrow 12 in FIG. 11.
- [0023] FIG. 13 is a right side elevation view of FIG. 12.
- [0024] FIG. 14 is a top view of FIG. 12.
- [0025] FIG. 15 is a perspective view of another element of the clamp assembly by itself.
- [0026] FIG. 16 is an elevation view in the direction of arrow 16 in FIG. 15.
- [0027] FIG. 17 is a right side elevation view of FIG. 16.
- [0028] FIG. 18 is a top view of FIG. 16.
- [0029] FIG. 19 is a perspective view of still another element of the clamp assembly by itself.
- [0030] FIG. 20 is an elevation view in the direction of arrow 20 in FIG. 19.
- [0031] FIG. 21 is a right side elevation view of FIG. 20.
- [0032] FIG. 22 is a top view of FIG. 20.
- [0033] FIG. 23 is a perspective view of an element of a motor head of the valve closure assembly by itself.
- [0034] FIG. 24 is an elevation view in the direction of arrow 24 in FIG. 23.
- [0035] FIG. 25 is a left side elevation view of FIG. 24.
- [0036] FIG. 26 is a perspective view of another element of the motor head by itself.
- [0037] FIG. 27 is an elevation view in the direction of arrow 27 in FIG. 26.
- [0038] FIG. 28 is a top view of FIG. 27.
- [0039] FIG. 29 is a right side view of FIG. 28.

[0040] FIG. 30 is a perspective view of an element of a head positioning mechanism of the valve closure assembly by itself.

[0041] FIG. 31 is a view in the direction of arrow 31 in FIG. 30.

[0042] FIG. 32 is a bottom view of FIG. 31.

[0043] FIG. 33 is a right side view of FIG. 32.

[0044] FIG. 34 is a top plan view of the valve closure assembly mounted on a railway tank car.

[0045] FIG. 35 is a front elevation view of FIG. 34.

[0046] FIG. 36 is a perspective view of a direct drive adapter by itself.

[0047] FIG. 37 is a top plan view of FIG. 36.

[0048] FIG. 38 is a vertical cross section view in the direction of arrows 38-38 in FIG. 37.

[0049] FIG. 39 is a cross section view in the direction of arrows 39-39 in FIG. 36.

#### DESCRIPTION OF THE PREFERRED EMBODIMENT

[0050] FIGS. 1 through 6 illustrate a presently preferred embodiment of valve closure assembly 50 of a valve closure system in accordance with principles of the invention. The valve closure assembly is adapted for mounting on the dome of a railroad tank car and operative coupling with a handle of a valve on the tank car for enabling the valve to be automatically closed in a situation where immediate valve closure is called for.

[0051] The dome of a representative of railroad tank car comprises a protective housing. The protective housing comprises a circular upright wall that is supported on a manway cover. The manway cover is supported on a flange of a circular manway opening in the tank dome. That assembly carries various valves whose handles are disposed external to the tank interior, but within the interior of the protective housing. Piping for the valves extends through the manway cover into the tank interior. The open top of the circular upright wall of the protective housing is closed by a circular cover that can be opened to provide access to the interior of the protective housing, and hence to the valve handles. With the cover open, the rim of the circular wall is exposed.

[0052] The present invention utilizes the exposed rim of the circular wall of the protective housing for securely mounting valve closure assembly 50 on a tank car dome. Valve closure assembly 50 comprises a clamp assembly 52 for clamping on the rim of the circular wall of the protective housing, a positioning mechanism 54 that is supported on the clamp assembly, and a motor head 56 that is positioned by the positioning mechanism for operative association with a valve handle that will enable system 50 to promptly close the associated valve by turning the valve handle when called upon to do so.

[0053] Motor head 56 comprises a motor 58, preferably an air motor, that is mounted upright on a motor mounting 60. Mounting 60 comprises a base plate 62 that is shown by itself in detail in FIGS. 26 through 29. Mounting 60 is securely fastened to positioning mechanism 54 through a

rectangular tie bar **64** using screws **66**. A bracket **68** is fastened by fastening elements **70, 72** to base plate **62**. A handle **74** is in turn fastened to bracket **68** by fasteners **76**. Handle **74** comprises a handlebar **78** and a grip **80**.

[0054] From this description it can be appreciated that mounting **60** comprises a horizontal platform on which motor **58** is securely mounted and a vertical wall that extends upward from that platform along side the motor. The horizontal portion of base plate **62** forms the horizontal platform of mounting **60**, and the vertical portion of base plate **62** and bracket **68** together form the vertical wall of the mounting. Handle **74** extends horizontally away from the side of that vertical wall opposite motor **58** near the upper end of the motor.

[0055] The shank of a respective headed screw **81** passes through each of six holes **83** in base plate **62** to thread into a respective threaded hole in an end of the air motor body. Tightening of the screws secures motor **58** on motor mounting **60**. It is considered desirable to protectively enclose motor **58** by a circular cylindrical shield **82**. A circular ring **84** is disposed around the air motor body at one end and clamped to the air motor body using three set screws **85** that are threaded into tapped through-holes in ring **84**. One end of shield **82** fits over ring **84** to establish concentricity of the shield to the motor body and contains several clearance holes that allow the shanks of headed screws **87** to pass through and thread into tapped holes in ring **84**. These screws are tightened to secure the shield to the ring. An annular ring seal **86** closes the annular space between the shield and the motor body at the opposite end. The horizontal platform that base plate **62** provides to support motor **58** comprises a central through-hole **89** surrounded by the six holes **83**. Through-hole **89** allows the motor shaft **91** to pass downward through the horizontal platform where a direct drive adapter **180** is coupled to the shaft using a hitch pin **93**. The upper end of motor **58** remains exposed to provide for connection of an air line (not shown) to the motor.

[0056] Positioning mechanism **54** comprises circular cylindrical rods **92, 94**, linear bearings **96, 98**, and a pillow block **100**. Rods **92, 94** are disposed horizontally spaced apart in mutually parallel relationship. Tie bar **64** at one end of rods **92, 94** and a second tie bar **102** at the opposite ends of the rods have counterbored through-holes that allow the rod ends to fit with precision to the counterbores of the tie bars. Screws **66** pass through the clearance holes **103** of one of four pairs of such clearance holes in base plate **62** to enter the through-holes in tie bar **64** and thread into tapped holes in the rods. The uppermost pair of holes **103** are used for fastening bracket **68** to base plate **62**, while the other three pairs provides for motor head **56** to be fastened to positioning mechanism **54** at any of three different elevations. Rods **92, 94** have tapped holes at their opposite ends, which seat with precision in the counterbores in the through-holes in tie bar **102**. Screws **104** fasten tie bar **102** and the rods together at that end in the same way so that the assembly of the two tie bars and the two rods forms a part of the positioning mechanism that can translate horizontally relative to pillow block **100**.

[0057] Detail of pillow block **100** is shown in FIGS. **30-33**. Linear bearings **96, 98** are fit to respective through-holes **106, 108** in pillow block **100**. Rods **92, 94** pass through

these linear bearings. Midway between and at a right angle to through-holes **106, 108**, pillow block **100** comprises a vertical through-hole **110**. A linear bearing **112** is fit to through-hole **110**. A circular rod **114** that has tapped holes at opposite ends passes through linear bearing **112**. A stop disk **116** is fastened to the upper end of rod **114** using a screw **118**. A screw **120** fastens clamp assembly **52** to the lower end of rod **114**.

[0058] During the process of assembling positioning mechanism, tubular bumpers **121** are fit onto ends of rods **92, 94** proximate each tie bar **64, 102**. Bumpers **121** limit the travel of pillow block **100** on rods **92, 94** so that the pillow block cannot strike either tie bar. The lengths of the bumpers are chosen to also provide sufficient clearance between the pillow block and the tie bars at the limits of pillow block travel so that pinch points are not present between the pillow block and the tie rods at the limits of pillow block travel.

[0059] FIGS. **7-22** show that clamp assembly **52** comprises a bracket assembly **122** fabricated from two base clamp parts **124, 126** and a strengthener plate **128**. In addition to bracket assembly **122**, clamp assembly **52** comprises a hand screw **130** that can be manually turned by a turning knob **159** shown in FIGS. **1-4** and **6**.

[0060] Part **126** is shaped to fit onto the rim of the protective housing of a railway tank car and comprises spaced apart vertical side walls **132, 134** that are joined by a horizontal top wall **136**, endowing the part with an inverted U-shape as shown by FIG. **17**. When the part is fit onto the protective housing rim, wall **132** is disposed inside the rim, wall **134** is disposed outside the rim, and top wall **136** rests on the top edge surface of the rim. Hence walls **132, 134** are spaced apart a distance that is greater than the thickness of the protective housing rim.

[0061] Part **124** is shaped to nest on part **126** and comprises a horizontal rectangular top wall **138** and legs **140, 142, 144, 146** depending from the four corners of top wall **138**. In the direction of the thickness of the protective housing rim, part **124** is longer than part **126**, but part **124** is shorter than part **126** in a direction at  $90^\circ$  to the thickness of the protective housing rim. Between leg **140** and leg **142**, part **124** has a downwardly open rectangular throat. A like throat exists between leg **144** and leg **146**. The two throats are dimensioned so that part **124** fits snugly onto part **126**, as shown in FIGS. **7** and **9**.

[0062] Strengthener plate **128** is rectangular in shape and is disposed against the outer surface of side wall **134** and between the lower ends of legs **142, 146**. The three parts **124, 126, 128** are aluminum alloy and are joined together by any suitable metallurgical joining technique to form bracket assembly **122**.

[0063] Top wall **138** has a circular hole **150** at its center that allows the lower end of rod **114** to pass through and abut top wall **136**. The latter wall has a countersunk hole **152** for allowing the flat head of screw **120** to seat flush in the countersink. Because the two walls **136, 138** are spaced vertically apart and rod **114** has a close fit to hole **150**, rod **114** is rigidly supported on clamp assembly **52**. Rigidity may be enhanced by joining rod **114** to wall **138**.

[0064] Strengthener plate **128** comprises a tapped hole **154** into which the threaded shank **156** of hand screw **130** is threaded. Side wall **134** may have a clearance hole **157** for

shank **156**, or it may provide an extension of the tapped hole in plate **128**. Although the thickness of wall **134** may be sufficient for the forces that it will experience during use of the valve closure system, that thickness may be insufficient to provide the desired length for the tapped hole needed for hand screw **130**. Strengthened plate **128** is therefore included to provide the desired tapped hole length into which shank **156** is threaded.

[0065] FIGS. 34-35 illustrate an example of how valve closure assembly **50** is used on a railway tank car. The tank car has a centrally located dome that has a protective housing **160**. The protective housing comprises a circular upright side wall **162** on which a top cover (not shown) is hinged for opening and closing the housing. Side wall **162** is supported on a manway cover **164** that is part of an assembly that carries four valves **V1, V2, V3, V4** in this example. The valves comprise respective handles **A1, A2, A3, A4** that are disposed external to the tank interior, but within the interior of housing **160**. With the top cover swung open, the rim of side wall **162** is exposed.

[0066] One or more of the valves is (are) opened, as appropriate to the particular procedure being performed on the tank car. A valve closure assembly **50** can be associated with the handle of any opened valve. The efficient geometry of valve closure assembly **50** allows multiple valve closure assemblies to be used concurrently. In this way a respective individual valve closure assembly **50** can be associated with a respective handle so that if all four valves are opened, they can be automatically closed by the respective valve closure assembly. The example shown in FIGS. 34-35 involves only a single valve closure assembly.

[0067] With hand screw **130** backed off sufficiently to provide a clearance from the distal end of shank **156** to side wall **132** of clamp assembly **52** that is sufficiently greater than the thickness of the rim of protective housing side wall **162**, handle **74** can be grasped to position the valve closure assembly over protective housing **160** with bracket assembly **122** positioned over the housing side wall rim and the downwardly open throat of the bracket assembly aligned with the rim and with motor head **56** positioned over valve **V1** and direct drive adapter **180** aligned with handle **A1**. The valve closure assembly is then lowered until top wall **136** of bracket assembly **122** comes to rest on the top edge surface of the housing side wall rim and adapter **180** comes into engagement with handle **A1**. Turning knob **159** of hand screw **130** is then grasped and turned to advance shank **156** against the outside of the housing rim thereby locking clamp assembly **52** to the protective cover. Other apparatus of the valve closure system that is not shown in the drawings is able to operate motor **58** when handle **A1** is to be operated to close valve **V1**. During mounting of assembly **50** on a tank car, the linear bearings facilitate the ability of positioning mechanism **54** to achieve the desired positioning of motor head **56** relative to clamp assembly **52**. They also facilitate any movement that may occur when motor **58** is operated, such as vertical motion arising from valve handle travel as the valve handle is turning. The linear bearings are commercially available products that incorporate circulating balls. Assembly **50** also adapts to a range of variations in valve location, a range in departure of a valve axis from vertical, and a range of thickness of the protective housing rim, without compromising the ability of the assembly to close an open valve.

[0068] Direct drive adapter **180** has features for fitting to handle **A1**. As motor **58** operates to turn the handle via adapter **180**, the handle may or may not translate vertically as it is turning. The range of vertical travel of pillow block **100** on rod **114** and a proper vertical setting of motor head **56** on tie rod **64** will enable the motor head to travel vertically with the valve handle so that the driving relation of the adapter to the handle is maintained until the valve is fully closed.

[0069] FIGS. 36-39 show direct drive adapter **180**. It comprises a cylindrical hub **182** with a square drive hole **184** for fitting onto motor shaft **91**. A transverse hole **186** is arranged for registration with a hole in the motor shaft so that hitch pin **93** can pass through both holes to pin the adapter to the motor shaft. A base plate **188** at the end of hub **182** carries two drive pins **190** on the face of the base plate that is opposite hub **182**. Drive pins **190** are arranged in a geometric pattern that allows them to fit into diametrically opposite holes **192** in the handles when assembly **50** is associated with one of them (see FIG. 34).

[0070] Because positioning mechanism **54** also endows the valve closure assembly with the ability to position motor head **56** at various horizontal distances from vertical rod **114**, it becomes possible to mount clamp assembly **52** within a range of locations around the rim of the protective housing with respect to a particular valve. This can be an aid to mounting of a valve closure assembly, particularly when multiple valve closure assemblies are used on a single tank car.

[0071] Positioning mechanism **54** is therefore capable of selectively positioning adapter **180** relative to the clamp assembly **52** to establish a spatial relationship of each to the other for enabling the clamp assembly to be placed at a desired location on dome wall **162** and the adapter to engage a valve handle. Positioning mechanism **54** comprises three degrees of freedom of motion for establishing the spatial relationship of the adapter to the mounting of assembly **50** on wall **162** that is provided by clamp assembly **52**. Two of those degrees of freedom of motion are in a horizontal plane of reference. They are provided as circular translation along a horizontal arc by the ability of pillow block **100** to turn on rod **114** about the vertical rod axis and as linear translation of rods **92** horizontally on pillow block **100**. The third degree of freedom of motion is provided as vertical translation by the ability of pillow block **100** to travel vertically on rod **114**.

[0072] Overall weight is reduced by using aluminum as the material of a number of the individual parts, such as clamp parts **124, 126, 128** and motor mount parts **62, 68**. An optional trapezoidal hole **170** in the upwardly pointing tongue of bracket **68** lightens its weight. Certain individuals will be able to carry a valve closure assembly **50** by grasping handle **74**, and able to install it on a tank car without help. A hole **172** near the tip end of the tongue of bracket **68** is available for attachment of an end of a lift or winch cable that can be used as an aid in lifting the valve closure assembly. Rectangular holes in side walls **132, 134** of bracket part **126** can lighten its weight. Assembly **50** can be used with a valve handle that is different from the ones shown by using an adapter that like adapter **180** attaches directly to motor shaft **91** using hitch pin **93**, but differs in how it mates with the particular valve handle.

[0073] Further examples of various adapters are disclosed in commonly owned, non-provisional patent application of

the same inventors, "Adapters And Adapter Systems For Valve Closure Systems And Valve Closure Assemblies", Ser. No. \_\_\_\_\_, of even date, (Attorney Docket PowellUS09).

[0074] While a presently preferred embodiment of the invention has been illustrated and described, it should be appreciated that principles of the invention are applicable to all embodiments that fall within the scope of the claims that follow hereinafter.

What is claimed is:

1. An assembly for turning an external handle of a tank dome valve about a vertical axis, the assembly comprising:

a mounting for removably mounting the assembly on a tank dome,

an adapter operated by a motor for engaging the valve handle and turning the handle when the motor operates, and

a positioning mechanism for selectively positioning the adapter relative to the mounting to establish a spatial relationship of each to the other for enabling the mounting to be placed at a desired location on the dome and the adapter to engage the valve handle, wherein the positioning mechanism comprises two degrees of freedom of motion in a horizontal plane for establishing the spatial relationship of the adapter to the mounting in the horizontal plane.

2. An assembly as set forth in claim 1 in which the mounting comprises a clamping mechanism for fitting and clamping onto a rim of an upright wall of the dome bounding a zone of the dome containing the valve.

3. An assembly as set forth in claim 2 in which the positioning mechanism comprises a first part supported on the clamping mechanism and a second part that comprises an association with the first part for providing the positioning mechanism with a first of the two degrees of freedom of motion that extends along a circular arc centered on the first part.

4. An assembly as set forth in claim 3 in which the first part comprises an upright post on the clamping mechanism and the association of the second part with the first part comprises a joint that allows the second part to turn on the post about a vertical axis of the post for causing the first degree of freedom of motion to extend along a horizontal circular arc centered on the vertical axis.

5. An assembly as set forth in claim 4 in which the joint comprises a linear bearing between the post and the second part to allow the second part not only to turn on the post about the vertical axis of the post but also to be positioned vertically along the post.

6. An assembly as set forth in claim 5 in which the positioning mechanism further comprises a third part that comprises an association with the second part for providing the positioning mechanism with a second of the two degrees of freedom of motion.

7. An assembly as set forth in claim 6 in which the association of the third part with the second part comprises a joint through which the third part is supported on the second part and which provides for selective positioning of the third part relative to the second part along a horizontal linear axis.

8. An assembly as set forth in claim 7 in which the second part comprises a central zone having a vertical through-hole in which the bearing is disposed and zones at either lateral

side of the central zone each having a respective horizontal through-hole containing a respective linear bearing, and the third part comprises rods received in the linear bearings in the horizontal through-holes.

9. An assembly as set forth in claim 8 in which the motor is mounted on a horizontal platform of a bracket that is attached to a bar that ties together ends of portions of the rods that extend from one longitudinal end of the second part, the bracket comprises a vertical wall extending upright from the platform and disposed between the motor and the second part, and the assembly further includes a handle for lifting the assembly attached to the vertical wall in vertically spaced relation to the horizontal platform and extending transversely of the vertical wall in a direction away from the motor.

10. An assembly as set forth in claim 9 in which the motor comprises an air motor having an output shaft that turns about a vertical axis and that protrudes through an aperture in the horizontal platform to extend below the horizontal platform, and the adapter attaches to the output shaft below the horizontal platform.

11. An assembly as set forth in claim 9 including another bar that ties together ends of portions of the rods that extend from a longitudinal end of the second part opposite the one longitudinal end, and bumpers disposed between each bar and the second part for preventing either bar from hitting the second part.

12. An assembly as set forth in claim 3 in which the positioning mechanism further comprises a third part that comprises an association with the second part for providing the positioning mechanism with a second of the two degrees of freedom of motion, and the association of the third part with the second part comprises a joint through which the third part is supported on the second part and which provides for selective positioning of the third part relative to the second part along a horizontal linear axis.

13. An assembly as set forth in claim 1 in which the positioning mechanism comprises a first part supported on the mounting, a second part that comprises an association with the first part for providing the positioning mechanism with a first of the two degrees of freedom of motion, and a third part that comprises an association with the second part for providing the positioning mechanism with a second of the two degrees of freedom of motion.

14. An assembly as set forth in claim 13 in which the association of second part with the first part comprises a joint that allows the second part to be selectively positioned on the first part along a circular arc centered on the first part.

15. An assembly as set forth in claim 14 in which the joint that allows the second part to be selectively positioned on the first part along a circular arc centered on the first part comprises a joint that allows the second part to be selectively positioned on the first part along a horizontal circular arc centered on the first part.

16. An assembly as set forth in claim 15 in which the association of the third part with the second part comprises a joint through which the third part is supported on the second part and which provides for selective positioning of the third part relative to the second part along a linear axis.

17. An assembly as set forth in claim 16 in which the first part comprises an upright post on the mounting, and the joint that allows the second part to be selectively positioned on the first part along a horizontal circular arc comprises a joint that allows the second part both to turn on the post as it is



selectively positioned along the circular horizontal arc centered on the vertical axis and also to be positioned vertically along the post.

**18.** An assembly as set forth in claim 13 in which the association of the third part with the second part comprises a joint through which the third part is supported on the second part and which provides for selective positioning of the third part relative to the second part along a linear axis.

**19.** An assembly as set forth in claim 18 in which the joint through which the third part is supported on the second part and which provides for selective positioning of the third part relative to the second part along a linear axis comprises a joint that provides for selective positioning of the third part relative to the second part along a horizontal linear axis.

**20.** An assembly as set forth in claim 1 in which one of the degrees of freedom of motion describes a circular arc in the horizontal plane and the other of the degrees of freedom of motion describes a straight line in the horizontal plane.

**21.** An assembly for turning an external handle of a tank dome valve about a vertical axis, the assembly comprising:

a mounting for removably mounting the assembly on a tank dome,

an adapter operated by a motor for engaging the valve handle and turning the handle when the motor operates, and

a positioning mechanism for selectively positioning the adapter relative to the mounting to establish a spatial relationship of each to the other for enabling the mounting to be placed at a desired location on the dome and the adapter to engage the valve handle, wherein the positioning mechanism comprises three degrees of freedom of motion for establishing the spatial relationship of the adapter to the mounting.

**22.** An assembly as set forth in claim 21 in which two of the three degrees of freedom of motion establish that portion of the spatial relationship within a plane of reference, and the third degree of freedom of motion establishes that portion of the spatial relationship transverse to the plane of reference.

**23.** An assembly as set forth in claim 22 in which the plane of reference is a horizontal plane.

**24.** An assembly as set forth in claim 21 in which two of the three degrees of freedom of motion are along non-parallel straight lines, and the third degree of freedom of motion is along a circular arc.

**25.** An assembly as set forth in claim 24 in which one of the straight lines is vertical, and the other, horizontal.

**26.** An assembly as set forth in claim 24 in which the circular arc is centered on a vertical axis.

**27.** A method of associating a valve operating assembly with a fluid-containing tank for enabling an adapter that is operated by a motor of the valve operating assembly to turn an external handle of a valve on the tank about an axis of turning while a mounting of the assembly is supporting the assembly on the tank, the method comprising:

relatively positioning the mounting and the adapter via a positioning mechanism of the valve operating assembly that has two degrees of freedom of motion in a plane of reference that is perpendicular to the axis of turning to establish a spatial relationship of the mounting and motor to each other in the plane of reference for placing the adapter in engagement with the valve handle and placing the mounting at a desired location on the tank.

**28.** A method as set forth in claim 27 in which the relatively positioning step comprises relatively positioning the mounting and the adapter via the positioning mechanism in a plane of reference that is horizontal.

**29.** A method of associating a valve operating assembly with a fluid-containing tank for enabling an adapter operated by a motor of the valve operating assembly to turn a valve on the tank about an axis of turning while a mounting of the assembly is supporting the assembly on the tank, the method comprising:

relatively positioning the mounting and the adapter via a positioning mechanism of the valve operating assembly that has three degrees of freedom of motion to establish a spatial relationship of the mounting and motor to each other for placing the adapter in engagement with the valve handle and placing the mounting at a desired location on the tank.

**30.** A method of associating a valve operating assembly comprising a mounting, a positioning mechanism, and an adapter operated by a motor with a dome of a fluid-containing tank comprising a valve having a handle that is external to the tank and an upright wall spaced horizontally from the valve handle for enabling the adapter to engage the valve handle and turn the handle about an axis of turning while the mounting is supporting the assembly at a desired location on the dome in horizontally spaced relation to the valve handle, the method comprising:

disposing the valve operating assembly vertically over the dome, lowering the assembly onto the dome, and causing the positioning mechanism to relatively position the mounting and the adapter to place the adapter in engagement with the valve handle and to place the mounting at a desired location on the upright wall.

\* \* \* \* \*