

(19) World Intellectual Property Organization
International Bureau



(43) International Publication Date
7 May 2009 (07.05.2009)

PCT

(10) International Publication Number
WO 2009/058708 A2

(51) International Patent Classification:
B41J 2/175 (2006.01) **G01F 23/00** (2006.01)

(21) International Application Number:
PCT/US2008/081264

(22) International Filing Date: 27 October 2008 (27.10.2008)

(25) Filing Language: English

(26) Publication Language: English

(30) Priority Data:
11/927,158 29 October 2007 (29.10.2007) US

(71) Applicant (for all designated States except US):
HEWLETT-PACKARD DEVELOPMENT COMPANY, L.P. [US/US]; 11445 Compaq Center Drive West, Houston, TX 77070 (US).

(72) Inventors; and

(75) Inventors/Applicants (for US only): **OGLE, Holli C** [US/US]; 1000 NE Circle Blvd., Corvallis, Oregon 97330 (US). **STATHEM, Ralph L.** [US/US]; 1000 NE Circle Blvd., Corvallis, Oregon 97330 (US). **BALDWIN, Marc A.** [US/US]; 1000 NE Circle Blvd., Corvallis, Oregon 97330 (US).

(74) Agents: **WASSON, Robert D.** et al.; Hewlett-Packard Company, Intellectual Property Administration, P.O. Box 272400, Mail Stop 35, Fort Collins, Colorado 80527-2400 (US).

(81) Designated States (unless otherwise indicated, for every kind of national protection available): AE, AG, AL, AM, AO, AT, AU, AZ, BA, BB, BG, BH, BR, BW, BY, BZ, CA, CH, CN, CO, CR, CU, CZ, DE, DK, DM, DO, DZ, EC, EE, EG, ES, FI, GB, GD, GE, GH, GM, GT, HN, HR, HU, ID, IL, IN, IS, JP, KE, KG, KM, KN, KP, KR, KZ, LA, LC, LK, LR, LS, LT, LU, LY, MA, MD, ME, MG, MK, MN, MW, MX, MY, MZ, NA, NG, NI, NO, NZ, OM, PG, PH, PL, PT, RO, RS, RU, SC, SD, SE, SG, SK, SL, SM, ST, SV, SY, TJ, TM, TN, TR, TT, TZ, UA, UG, US, UZ, VC, VN, ZA, ZM, ZW.

(84) Designated States (unless otherwise indicated, for every kind of regional protection available): ARIPO (BW, GH, GM, KE, LS, MW, MZ, NA, SD, SL, SZ, TZ, UG, ZM, ZW), Eurasian (AM, AZ, BY, KG, KZ, MD, RU, TJ, TM), European (AT, BE, BG, CH, CY, CZ, DE, DK, EE, ES, FI, FR, GB, GR, HR, HU, IE, IS, IT, LT, LU, LV, MC, MT, NL, NO, PL, PT, RO, SE, SI, SK, TR), OAPI (BF, BJ, CF, CG, CI, CM, GA, GN, GQ, GW, ML, MR, NE, SN, TD, TG).

Declarations under Rule 4.17:

- as to the identity of the inventor (Rule 4.17(i))
- as to applicant's entitlement to apply for and be granted a patent (Rule 4.17(ii))
- as to the applicant's entitlement to claim the priority of the earlier application (Rule 4.17(iii))

Published:

- without international search report and to be republished upon receipt of that report



WO 2009/058708 A2

(54) Title: INK LEVEL DETECTION BY ELECTRONIC MEANS

(57) Abstract: An ink cartridge (1) configured to hold an ink includes a substantially hollow body (23) including an inner space (21) and a substantially continuous inner wall (5). An optical prism (2, 2', 2'') in the inner space (21) is disposed at a predetermined distance from the continuous inner wall (5) such that an ink pocket (6) is defined by a prism wall (17) and the continuous inner wall (5). The prism (2, 2', 2'') includes at least one reflection site (4) formed at an angle configured to reflect light from a light source through the prism (2, 2', 2'') at a predetermined height relative to a bottom (10) of the body (23). If ink is present in the ink pocket (6) at a level below at least a portion of the reflection site (4), the ink does not block the light reflected off of the portion of the reflection site (4) from traveling across the ink pocket (6) at the predetermined height, such that the reflected light is externally detectable by electronic means (16).

5

INK LEVEL DETECTION BY ELECTRONIC MEANS

BACKGROUND OF THE INVENTION

Previous attempts have been made to render customer viewable the amount of ink in an ink cartridge of an inkjet printer. Other attempts have been made to manufacture and implement a dependable electrical ink supply detection mechanism that informs customers, for example, via their computer screen or an electrical signal sent their printer when their cartridges are almost out of ink.

Attempts have been made using light beams reflected or refracted by prisms have been previously tried to produce both a customer viewable and electrically detectible means of ink supply detection. Furthermore, a prism structure has been positioned in an ink cartridge for purposes of ink level detection.

A principle of optics, called Total Internal Reflection (TIR), is relevant to this discussion of light beams and prisms. TIR occurs when an internal light ray strikes an internal segment of the prism at an angle greater than a certain critical angle with respect to an angle normal to the light beam and the internal segment. If the light beam hits the prism segment at or greater than the certain critical angle, and if the refractive index is lower on the outside than on the inside of the prism, such as when the prism is surrounded by air, no light at the critical angle or above can pass through to the outside of the prism. In that case, all of the light is reflected within the prism. Given the materials from which prisms are usually made (e.g., glass or polymeric materials, the critical angle for such prisms are usually between the angles of 40 and 50 degrees)

Previous attempts to utilize light and prisms with an ink cartridge to produce readable light signals related to ink level in the ink cartridge tended to

produce signals which are unclear, from either an electrical detection or a human viewable perspective. The on/off signal produced is generally not strong.

5 BRIEF DESCRIPTION OF THE DRAWINGS

Features and advantages of embodiments of the present disclosure will become apparent by reference to the following detailed description and drawings, in which like reference numerals correspond to similar, though perhaps not identical, components. For the sake of brevity, reference numerals or features having a previously described function may or may not be described in connection with other drawings in which they appear.

Figure 1 depicts a semi-schematic view of an embodiment of an ink cartridge.

15 Figure 2A depicts a semi-schematic view of an embodiment of an optical prism.

Figure 2B depicts a semi-schematic view of another embodiment of an optical prism.

Figure 3 depicts a semi-schematic view of an embodiment of ink cartridge having ink therein.

20 Figure 4 depicts a semi-schematic cutaway view of a portion of an embodiment of a printer.

Figure 5A depicts a semi-schematic side view of an embodiment of a prism.

25 Figure 5B depicts a semi-schematic side view of another embodiment of a prism.

Figure 5C depicts a semi-schematic front view of the prism of Figure 5B.

Figure 6 semi-schematically depicts user-facing displays A, B, C and D from various different prisms according to an embodiment.

30 Figures 7A, 7B, 7C, 7D and 7E depict semi-schematic views of five different embodiments of an inkjet cartridge prism wall.

Figure 8 depicts a semi-schematic view of still another embodiment of an ink cartridge including two prisms.

Figure 9 depicts a semi-schematic perspective view of an embodiment of a "U"-shaped prism.

5 Figure 10 depicts a semi-schematic perspective view of the "U"-shaped prism of Figure 9 in an embodiment of the ink cartridge.

Figure 11 depicts a semi-schematic perspective view of an embodiment of an "L" shaped prism.

10 DETAILED DESCRIPTION

Embodiments of the ink cartridge disclosed herein allow a customer to view, with a glance at his/her printer or with an equivalent electronic means, the amount of ink remaining in the particular ink cartridge. This is achieved by positioning a light-emitting diode (LED) 3 or other comparable light source in, on
15 or near the ink cartridge, such that the light beam from the light source is able to reach a designated place inside of the ink cartridge. In one non-limiting example, the light source is placed just outside a bottom portion of the ink cartridge. The ink cartridge itself advantageously contains at least one optical prism through which a light signal is accurately beamed to a viewing window
20 open to a user's eye and/or to an electrical detector which is configured to register the light signal. Based on the level of ink in the ink cartridge, various light signals may be produced.

Figure 1 shows an ink cartridge 1 formed of a substantially hollow body
23 with an LED 3 positioned below the lower right corner. It is to be understood
25 that the LED 3 is generally positioned such that light from the LED 3 travels upward through the cartridge 1 and into a prism 2 operatively positioned within an inner space 21 of the substantially hollow body 23 of the ink cartridge 1. In some non-limiting embodiments, the prism 2 is attached to the bottom side 10 of the ink cartridge inner space 21. Embodiments of the prism 2 are generally
30 smaller than both the length and width of the inner space 21 of the ink cartridge 1. This allows ink to flow freely back and forth around the prism 2 in the ink

cartridge inner space 21, including in the ink pocket 6, which is a space formed between the prism 2 and the adjacent inner wall 5 of the cartridge 1.

The light is reflected off of the optical prism 2 at a predetermined reflection angle formed on the prism 2 at specific reflection sites 4. The reflection angle(s) are often formed by cutting out prism material in angular cut-outs on the surface thereof. In one embodiment, the predetermined reflection angle is 45° , and in another embodiment, the angle ranges from approximately 40° to 50° , depending, at least in part, on the material of the prism 2.

The light beam reflected from the prism 2 is directed out of the cartridge 1 approximately perpendicularly to the original direction of the light beam. In some instances, the inner wall 5 of the cartridge 1 is substantially vertical (i.e., at least a portion of the inner wall 5 is vertical) and parallel to the original light beam, and as such, the reflected light beam is horizontal with respect to the vertical inner wall 5 of the cartridge 1. However, depending on the angle of incidence with the reflection site 4, it is possible for the light to travel out of the cartridge 1 in a direction other than horizontal. It is also possible for the light to bounce around the prism 2 and the ink cartridge 1 before it exits the cartridge 1 through the appropriate area. This light beam directed from the reflection site 4 out of the cartridge 1 is then viewable by a user's eye 20 (see, for example, Figure 7A) or detectible by a detector 16 through a window 7 in the printer 8 (shown in Figure 4), the window 7 being adjacent to the inner wall 5 of the cartridge 1.

Figures 2A and 2B show embodiments of two different prisms 2 with several reflection sites 4 on each prism 2, and with each reflection site 4 formed at substantially the same angle (e.g., 45°) in relation to the prism 2. Figure 2A shows an embodiment with reflection sites 4 formed by jagged cut-outs on the ink pocket 6 side of the prism 2. Figure 2B shows another embodiment with reflection sites 4 formed by a series of 45° angle steps on the wall of the prism 2 opposite the ink pocket 6.

Figure 3 shows an embodiment in which an optical prism 2 is positioned inside an ink cartridge 1 that is partially filled with ink. This embodiment of the prism 2 includes three approximately 45° angle reflection sites 4 cut out on the

side of the prism 2 opposite the ink pocket 6. The LED 3 is positioned below the ink cartridge 1 and directly below the prism 2 such that the LED 3 light shines upward and hits the three reflection sites 4. The three 45° cut-out reflection sites 4 in turn reflect three separate light beams at an angle of about 90° to the direction of the original upward light beam from the LED 3. The three light beams from the three reflection sites 4 pass horizontally, or near horizontally, across the prism 2 to the ink pocket 6 side of the prism 2. As shown in Figure 3, the ink in the ink cartridge 1 is at a level which reaches above the lowest of the three reflection sites 4 and its corresponding light beam. Thus the lowest of the three light beams is blocked by the ink in the ink pocket 6, and thus is not viewable through the viewing window(s) 7 of the printer 8 (shown in Figure 4). The other two beams, which are not blocked by ink in the ink pocket 6, pass across the ink pocket 6 and shine through the inner wall 5 of the ink cartridge 1 and through the viewing window(s) 7 of the printer 8, such that eyes 20 of viewers and/or detectors 16 may perceive them.

It is believed that the light travels from the LED 3 through the prism 2 and out of the cartridge 1 according to the principle of Total Internal Reflection (TIR), and the fact that light rays travel through ink with difficulty or not at all. According to the TIR principle, the interface between the ink and the prism 2 (at the predetermined angle) and the interface between the air and the prism 2 reflect/refract the light differently. Furthermore, if the ink pocket 6, located between a vertical prism wall 17 and the most nearly adjacent cartridge wall 5, contains ink at a level below a reflection site 4, light travels from that reflection site 4, out the prism 2 and through the cartridge wall 5 and viewing window 7. When the light beam from the prism 2 interfaces with air as it exits the prism 2 into the ink pocket 6, it travels essentially unrefracted through the air and hits the inner wall 5 of the ink cartridge 1 at an angle perpendicular to the original light beam (e.g., if the reflection site 4 is about 45°), thus passing through the viewing window 7.

If the ink pocket 6 between the prism 2 and the ink cartridge wall 5 is filled with ink to a level above of one of the reflection sites 4 in the prism 2, the light reflected from that reflection site 4 is substantially blocked by the ink. This

prevents the light from traveling across the ink pocket 6 to the ink cartridge wall 5. As such, when enough ink is present to fill the ink pocket 6 to the level of a given reflection site 4, the light from the given reflection site 4 never reaches the viewing window 7. For example, when the ink container 1 is filled with pigment-based ink to the level shown in Figure 3, the lights from the two top reflection sites 4 on the prism 2 will shine through the viewing window 7, while the light from the lowest reflection site 4 will be lost in the ink. It is to be understood, however, that when the ink present in the cartridge 1 is dye-based ink, it is possible for some faint amount of light to reach the viewing window 7 from even those reflection sites 4 located at or below the ink level.

It is to be understood that if the ink level in the ink pocket 6 is above a portion of the reflection site 4 and not the entire reflection site 4, a light signal may be reflected from the portion of the reflection site 4 that is above the ink level. Such a light signal is weaker than a light signal generated from a reflection site entirely above the ink level.

Therefore, the phenomenon of effectively generating light signals for detection of ink level in embodiments of the ink cartridge 1 disclosed herein is made possible both by the principals of TIR, which governs how the light is reflected by the reflection sites 4 within the prism 2, and also by the fact that the light beamed from the prism 2 can be blocked substantially completely with ink. As previously described, when ink is present in the ink cartridge 1 at a level which blocks a given reflection site 4, the light is prevented from beaming out of the prism 2. But, when ink is not present in the ink cartridge 1 at a level which blocks at least a portion of the reflection site 4, at least a portion of the light beams out of the prism 2 and a detectable and/or visible signal is generated.

More specifically, the light beams are reflected from the respective reflection sites 4 to the interface between the vertical prism wall 17 and the ink pocket 6. When an area of the vertical prism wall 17 directly opposite a reflection site 4 is blocked by ink present in the ink pocket 6 (e.g., the ink pocket is relatively full of ink), the light beam from that reflection site 4 is not able to beam from the vertical prism wall 17 through the ink pocket 6 and out of the ink

cartridge 1. In contrast, when the interface is not covered or blocked by ink present in the ink pocket 6 (e.g., the ink pocket 6 is relatively empty of ink), the light beam from that reflection site 4 is able to beam from the prism 2 through the ink pocket 6 and out of the ink cartridge 1.

5 As the ink cartridge 1 is used, the ink level reduces within the ink cartridge 1, thereby exposing additional reflection sites 4 and those areas of the vertical prism wall 17 directly opposite those reflection sites 4. As the ink level in the ink pocket 6 becomes further depleted and additional reflection sites 4 become exposed above the ink level, individual light bands (corresponding to
10 the exposed reflection site 4) continue to “turn on” and are sequentially added and shown on a visual display or signaled to an electrical detector 16, thereby providing a countdown to when the ink supply in the cartridge 1 is used up.

Referring now to Figure 4, a user inserts a filled ink cartridge 1 into a printer 8. If the ink cartridge 1 is loaded properly, a supply light may illuminate
15 at the top of the unlit vertical light string 9 in the viewing window 7 of the printer 8 to indicate proper installation of the ink cartridge 1. According to the pattern shown in Figure 4, the top light or lights for each cartridge 1 are illuminated, thus indicating proper installation.

Each cartridge 1 has a corresponding vertical light string 9 viewable by
20 the user, the number of lights illuminated in the string 9 depending on the amount of ink present in the individual cartridge 1. Additional lights will become visible as more ink is used. When a particular ink cartridge 1 is empty, the supply light may then blink to indicate that the user should replace the particular cartridge 1.

25
In Figure 4, a specific portion of a printer 8 is shown with the viewer window 7 and a horizontal row of six light strings 9, each of which corresponds to one of six different ink cartridges 1. Furthermore, each light string 9 has four lights that may be illuminated and displayed to the user. It is to be understood
30 that the number of lights in a string 9 correspond to the number of reflection sites 4 in the corresponding cartridge 1. When fully lit, each of each of the individual lights together forms the vertical column or string 9 of lights. In the

particular embodiment shown in Figure 4, the top horizontal row of lights indicates, when lit, that the ink cartridges 1 are inserted correctly. It is to be understood that as the next light (descending from the top light) in a string 9 becomes illuminated, the ink supply within the corresponding cartridge 1 has
5 depleted to a level that exposes a reflection site 4, thereby allowing the light from that reflection site 4 to be viewed by the user. As such, for the light strings 9 in which two, three, or four lights are illuminated, the ink in the cartridge 1 is becoming depleted and is, to some degree or another, getting nearer to empty. The extent of emptiness is gauged by the number of lights lit in the vertical
10 string 9. In this embodiment, when the ink cartridges 1 are substantially empty, all of the lights in each of the six vertical light strings 9 are illuminated. When the ink cartridges 1 are substantially filled, no lights are shown, except for the top light of each column which indicates correct insertion.

Figure 4 depicts one of various embodiments of the visual display in the
15 viewer window 7 that may be provided to the user. It is to be understood that the thickness of the individual colored light strings 9 may be changed by varying the length or configuration of the reflection sites 4 in the individual ink cartridges 1. However, it is to be understood that in order to achieve the desirable reflecting properties, the angle (e.g., approximately 45°) at which the reflection
20 site 4 is cut out from the prism 2 should remain within a desirable range in order to achieve a light beam from the prism 2 which accurately travels to the viewer window 7. For example, as long as the reflection site 4 is cut at the correct angle, thinner, vertical light strings 9 may be achieved by constructing reflection sites 4 having substantially horizontally narrower lengths, whereas thicker
25 vertical light strings 9 may be accomplished by constructing horizontally thicker reflection sites 4. In this particular embodiment, even though primarily designed for a viewer's eye 20, the information on this display could also be registered by an electrical detector 16 (as shown in Figure 4).

Alternative visual displays may also be achieved by varying the geometry
30 of the prism 2. Figures 5A and 5B illustrate two examples of such variations. Each of the embodiments shown respectively in Figures 5A and 5B, though visibly different than Figures 2A and 2B, provide 45° reflection sites 4 for the

light beam coming from the LED 3 at the bottom of the prism 2. In the embodiment of Figure 5A, the basic right triangular prism shape is maintained (since the entire hypotenuse side of the right triangular prism is at an angle of 45° with respect to the vertical pointing light beam from the LED 3). However, there are no cut-out portions in the prism 2 in Figure 5A. Such an embodiment is able to reflect light beams to the viewing window 7 as indicated in Figure 5A. It is to be understood that the intensity of the light in such an embodiment is normally not bright enough to be easily viewable by the user. In another embodiment of the prism 2 shown in Figure 5B, there are a series of three jagged 45° cutouts 18 on the vertical wall 17 of the prism 2 facing the ink pocket 6 (shown in Figure 5B). These cut-outs 18 do not serve as reflection sites 4, but rather as areas that actually reflect the light back into the prism 2. It is the uncut rectangular areas 19 in the vertical prism wall 17 directly above and below these cutouts 18 which enable the light to exit the prism 2 into the ink pocket 6. The light beamed from these rectangular areas 19 is the light that is actually perceived by the detector 16 or by the eye 20. The light that is beamed from these areas 19 is beamed from reflection sites 4 in other areas of the prism 2.

Figure 5C shows a front view of the prism 2 of Figure 5B as it would be seen by the viewer. This user's view is actually a view of the prism wall 17 that faces the ink pocket 6. The cut-out areas 18 reflect no light signal, while the rectangular areas 19 above and below the cut-out areas 18 reflect the light signals.

Figure 6 depicts examples of alternative visual displays: A, B, C and D that may be achieved based on the geometry of the prism 2, and in particular on the shape of the reflection sites 4. For example, displays A and D in Figure 6 illustrate how the lights in a light string 9 would look when the prism 2 is formed by making cut-outs 18 in the prism 2 which cause the light to reflect within the prism 2 and areas 19 which cause the light to reflect out of the vertical prism wall 17, similar to the embodiments shown in Figures 5B and 5C. Display D illustrates an embodiment in which the prism 2 has three reflection sites 4. Display B in Figure 6 illustrates a series of horizontal light bands extending across the viewing window 7, which results from extending the reflection sites 4

horizontally across the entire side of the prism 2 that reflects the light from the LED 3 out the vertical prism wall 17 as a straight horizontal band. Display C in Figure 6 shows gaps in the light bands, which may be formed by constructing intermittent portions horizontally across the reflection sites 4. In one
5 embodiment, the intermittent portions are generally cut at an angle at which light will not reflect at 90° toward the vertical prism wall 17. In another embodiment, the reflection sites 4 include a non-reflective material at intermittent portions horizontally across the reflection sites 4. The effect of these intermittent
10 portions is that the viewer sees a series of discrete portions of light positioned horizontally in relation to each other rather than in a solid horizontal band. Such embodiments are not intended to be limiting, but show some general techniques by which various kinds of visual light signals may be achieved.

Figures 7A, 7B, 7C, 7D and 7E show five slightly different embodiments of the ink cartridge 1 and prism 2, all of which employ a notch 11 or protrusion
15 11', either in the ink pocket-side of the prism wall 17, the opposite side 24 from the prism wall 17, or on the opposite side of the ink pocket 6 on the inner wall 5 of the ink cartridge 1. The notch 11 or protrusion 11' serves a light-interrupting function when ink fills all or part of the notch 11 or blocks the protrusion 11'.

While the LED 3 shown in Figures 7A through 7E is positioned to direct
20 the light beam to one of the reflection sites 4, it is to be understood that the LED 3 may be positioned to direct light beams to each of the reflection sites 4 such that multiple light signals (some of which exit the cartridge 1 via wall 5 and others of which exit the cartridge 1 via the bottom 10) may be generated.

These embodiments include an additional reflection site 4', which directs
25 the light toward the bottom 10 of the ink cartridge 1. In the embodiments of Figures 7A, 7B and 7C, a light beam from a reflection site 4 in the prism 2 is directed, via the additional reflection site 4', to the notch 11, which is cut out of a section of the prism wall 17. In the embodiment of Figure 7D, the additional reflection site 4' directs the light down through the ink pocket 6. In the
30 embodiment of Figure 7E, the additional reflection site 4' directs the light down through the prism 2.

In the case of Figures 7A and 7B, the notch 11 extends all the way down the vertical prism wall 17 to the bottom 10 of the ink cartridge 1. These notches 11 form recesses R in the prism 2 which increases the volume of the ink pocket 6. In Figure 7C, the notch 11 is cut out to extend part of the way down the vertical prism wall 17, thereby forming a smaller recess R than that shown in Figures 7A and 7B. It is to be understood that this smaller recess R also increases the ink pocket 6 volume somewhat. In Figure 7D, the protrusion 11' is constructed by positioning an additional reflection site 4' on a piece of material 15 protruding from the wall 5 of the ink cartridge 1 that forms one side of the ink pocket 6. In Figure 7E, a light beam directly from the light source 3 is directed to the notch 11, which is positioned between the reflection site 4 and the bottom 10 of the cartridge 1 along the wall 24 of the prism 2 opposed to the vertical prism wall 17. This notch 11 forms a recess R which increases the volume of the inner space 21. It is to be understood that when this notch 11 has ink therein, the light is blocked before it even enters the prism 2.

Figure 7A shows an embodiment with the capability of having a horizontal light signal reflected across the ink pocket 6 and out of the ink cartridge 1 and a vertical light signal reflected down from a second reflection site 4' on the prism wall 17 and out the bottom 10 of the ink cartridge 1. It is to be understood that in the embodiment of Figure 7A, since the ink pocket 6 and the notch 11 are filled with ink, the light signals are blocked from exiting the ink cartridge 1 at these particular points. However, it is to be understood that two separate light signals emitting from different parts of the ink cartridge 1 may be registered (when the ink level decreases such that blockage does not occur) by electrical detection 16, the human eye 20, or a combination of the two.

As previously stated, in Figures 7A and 7B, the notch 11 is cut out of the vertical prism wall 17 such that it extends to the bottom 10 of the ink cartridge 1. If there is any amount of ink in the ink pocket 6, it is likely to block the passage of light through the notch 11. As such, in Figure 7A no light signals would be emitted from the ink cartridge 1 (except at those reflection sites 4 above the ink level), and in Figure 7B, the light signal would be beamed out of the ink

cartridge 1 from all the reflection sites 4 receiving light beams. The notches 11 of Figures 7A and 7B are different sized, but they achieve a similar result.

A variant embodiment of Figures 7A and 7B may be achieved by placing the notch 11 on the opposite wall 24 of the prism 2 from the vertical prism wall 17, as shown in Figure 7E. As previously stated, if the light source 3 is positioned directly beneath the notch 11, the light signal will be detected when there is very little, if any, ink left in the ink cartridge 1, as the ink is in the position to block the light from entering the prism 2. The embodiment of Figure 7E, like that of Figure 7A, also includes the capability of having both a horizontal light signal reflected across the ink pocket 6 and out the side 5 of the ink cartridge 1, and a vertical light signal reflected down from the second reflection site 4' on the vertical prism wall 17 and out the bottom 10 of the ink cartridge 1.

Referring now to Figure 7D, the notch 11 is formed such that it protrudes from the inner wall 5 of the cartridge 1. In this embodiment, the notch 11 includes a second reflection site 4' that receives the redirected light from the reflection site 4. The second reflection site 4' directs the light all the way down through the ink pocket 6 (when the ink level is such that light is able to pass) to the bottom 10 of the cartridge 1. As with the embodiments of Figures 7A and 7B, the embodiment of Figure 7D is designed such that if there is any amount of ink in the ink pocket 6 it is likely to block the passage of light through the cartridge 1, thereby preventing a light signal from reaching either an electrical detector 16 or the eye 20 of a user.

The notch 11 in Figure 7C (unlike that shown in Figure 7B) does not extend all the way down the vertical prism wall 17, but is configured to extend a short way down the wall 17. The result is that when the light (reflecting from both reflecting sites 4, 4') is beamed through the notch 11 when no ink is present in the notch 11. After passing through the notch 11, the light beam reenters the prism 2 at the bottom side of the notch 11 and travels down the prism 2 to the bottom 10 of the ink cartridge 1 as a light signal to be detected by an electrical detector 16 or viewed by the eye 20 of a user. This smaller notch 11 of Figure 7C generates a light signal earlier than the notches 11 of Figures 7A, 7B and 7D, at least in part because ink will still be present in the ink pocket

6 (through which the light signals of Figures 7A, 7B and 7D travel) and the ink cartridge 1 as a whole, when the smaller notch 11 becomes empty.

The embodiment of the ink cartridge 1 shown in Figure 8 exemplifies two different aspects that can be employed either together or separately. In the first aspect, Figure 8 shows an embodiment in which the ink cartridge 1 is tilted to create a situation in which the ink in the ink cartridge 1 accumulates in one end (opposed to the end in which the ink pocket 6 is formed) of the ink cartridge 1. This results in the ink pocket 6 running low on ink sooner than the area at the opposite side of the ink cartridge 1. This opposite side is generally the area of the ink cartridge 1 from which ink is dispensed to the printer 8. Such positioning results in the ink level detection function being triggered to show a low level of ink even when a certain amount of ink still remains in the ink cartridge 1. Thus, the user is alerted before the ink cartridge 1 is completely empty of the need to prepare to replace the old cartridge with a new cartridge.

In the second of the two different aspects, Figure 8 shows the use of two separate optical prisms 2, 2' in an ink cartridge 1, the prism 2 on the right being that previously described, and the prism 2' on the left forming a second reflective site 4' for at least one of the light signals. The prism 2 forms the ink pocket 6 with the inner wall 5 and has reflection sites 4 consisting of 45° cutouts on the side of the prism 2 opposite the ink pocket 6. This embodiment of the prism 2 is notable for having, in addition to the previously mentioned reflection sites 4, one reflection site 4'' that is a 45° cutout which reflects the vertical light beam from the LED 3 in the opposite direction of the other reflection sites 4. More particularly, this reflection site 4'' directs a light beam in a direction (i.e., perpendicular to the original light beam) away from the ink pocket 6 and toward the second prism 2', which, in this embodiment, is positioned to the left of the first prism 2.

The second optical prism 2' to the left of the first prism 2 is generally smaller than the first prism 2 and forms a second ink pocket 6' with the first prism 2. The second prism 2' may be positioned anywhere along the bottom between the prism 2 and the end of the cartridge 1 opposed to the ink pocket 6. It is to be understood that lower levels of ink may be detected the closer the

second prism 2' is located to the dispenser 22. The second prism 2' has at least one 45° cut-out which forms a second reflection site 4' that receives a light beam from the reflection site 4'' of first prism 2. The reflection site 4' on the second prism 2' then reflects the light beam so that the light travels directly
5 down to the bottom 10 of the ink cartridge 1 where it can be detected. When the level of ink in this second ink pocket 6' is high enough to block the light beam from traveling through the second ink pocket 6' to the second prism 2', then no light signal is generated by the second ink prism 2'.

The aspect of Figure 8 relating to the second prism 2' serves to provide a
10 system whereby different ink levels in the ink cartridge 1 can be detected at different locations in each prism 2, 2'. Because ink is depleted sooner from the first ink pocket 6 than from the second ink pocket 6', the light beams generated by the first prism 2 and directed out the ink cartridge wall 5 through the first ink pocket 6 are detectible sooner than the light beam transmitted from the first
15 prism 2 to the second prism 2' and out the bottom 10 of the ink cartridge 1. When this two prism 2, 2' arrangement is combined with the slanted position aspect of the ink cartridge 1 as shown in Figure 8, even the light signal from the second prism 2' is generated before the ink in the ink cartridge 1 is completely depleted. The non-limiting embodiment combining both of these two aspects
20 may be used in a system employing both visual light signals (e.g., the light signals beamed out the ink cartridge wall 5 from the first prism 2) and electrically detectible light signals (e.g., the light signals beamed from the first prism 2 to the second prism 2' and down through the bottom 10 of the ink cartridge 1). It is to be understood that any configuration of detection may be used in such an
25 embodiment, for example, all of the light signals may be viewable by the user, or the light signals from the first prism 2 may be electrically detectible while the light signals from the second prism 2' may be viewable by the user.

Furthermore, like Figures 7A and 7E, Figure 8 also has the aspect of having light signals exiting from both the side 5 of the ink cartridge 1 and the
30 bottom 10 of the ink cartridge 1. Thus again, two separate light signals emitting from different areas of the ink cartridge 1 can be registered by either electrical detection 16, the human eye 20 or a combination of the two.

Referring now to Figure 9, another embodiment of a prism 2'' is shown as a squared-off "U" shape, with the two ends E1, E2 of the "U" configured to be positioned on the bottom 10 (not shown in this Figure) of the ink cartridge 1. The light source 3 generates a light beam which enters the prism 2'' from one of the ends E1 and travels up one side of the "U" to a first reflection site 4, which is a 45° cut-out at the first perpendicular turn of the "U" shaped prism 2''. This first reflection site 4 reflects the light 90° such that it travels straight across the top side T of the upside down "U" shaped prism 2''. Along the way across the top side T of the prism 2'', the light beam reaches a channel 12 which essentially forms a complete three-dimensional space or cut-out in the top side T of the "U". The light traveling from the first reflection site 4 exits one section of the prism 2'' and travels across the channel 12 to where the top side T of the prism 2'' resumes at the other side of the channel 12. The top side T of the prism 2'' is therefore divided into two separate sections S1, S2, one of the first sections S1, S2 being the portion before the channel 12 and the other of the sections S2, S1 being the portion after the channel 12. It is to be understood that the two sections S1, S2 are discontinuous, but are optically aligned. As such, if the channel 12 is not substantially filled with ink, the light beam can easily pass through the channel 12 and resume traveling through the second section S2 of the top side T of the prism 2''.

In the second section S2 of the prism 2'' a spaced distance from the channel 12, there is a notch 13 (forming another channel C) which unlike the channel 12, does not form a complete three dimensional space dividing the prism 2''. Rather, the notch 13, C is a cut-out which extends approximately half-way into the width of the top side T and half-way across the light pathway through the top side T. As such, the notch 13, C divides a portion of the second section S2 into two opposed ends S2E1, S2E2. Therefore, approximately half of the light beam, which had previously traveled through the channel 12 (in the absence of ink), is able to travel through the portion 14 of the top side T, S2 directly adjacent the notch 13, C with no interruption. The other half of the light beam is able to pass through the second section first opposed end S2E1 and then through the notch 13, C if ink is absent from the notch 13, C. It is to be

understood that the light beam then passes through the second section second opposed end S2E2. Thus, the light beam functions as a half-signal when the notch 13, C is blocked by ink, and functions as a full signal when the notch 13, C is not blocked by ink.

5 After passing through the notch 13, C and/or the portion 14, the light then encounters another reflection site 4' formed by a 45° cut-out at the second perpendicular turn of the "U" shaped prism 2". This second reflection site 4' reflects the light 90°, thereby directing the light downward in a third side of the "U" shaped prism 2" and toward the ink cartridge bottom 10. The light beam
10 exits the ink cartridge 1 as a light signal to be detected electrically 16 and/or by the eye 20. In order to assure that this second reflection site 4' reflects the light downward to be detected, whether or not the ink level is at or above the reflection site 4', the reflection site 4' is designed to have a permanent air pocket (not shown) around it. Formation of the air pocket may be accomplished by
15 providing an extra layer of the material of the prism 2", such as glass or polymeric material, around the reflection site 4'. This extra layer is positioned such that an air space exists between it and the second reflection site 4'. The air pocket assures that the second reflection site 4' on the third side of the "U" always reflects the light downward to be detected.

20 In Figure 10, the "U" shaped prism 2" of Figure 9 is shown positioned in an embodiment of the ink cartridge 1. This two-sectioned prism 2" has a light signal generated from and that is detectible through the bottom 10 of the ink cartridge 1. In the embodiment shown in Figure 10, ink is blocking the notch 13, C. This results in a weaker light signal being detected, because the portion of
25 the light beam traveling through the portion 14 of the top side T, S2 is detected, while the portion of the light beam encountering the filled notch 13, C is blocked from further travel, and thus is not detected.

30 The embodiment of Figure 10 also includes a series of four optical prisms 2 graduated in height positioned to the right of the "U" shaped prism 2". Each of these optical prisms 2 has a 45° reflection site 4 at the top of each prism 2, where each reflection site 4 is located at a different height from the bottom 10 of the cartridge 1. When the ink level in the ink pocket 6 is below the respective

reflection sites 2, four separate light beams are transmitted across the ink pocket 6 to the right wall 5 of the ink cartridge 1. As previously described, each light beam becomes active (i.e., is not blocked) when the ink in the ink pocket 6 is depleted to a level below the particular reflection site 4.

5 As shown in Figure 10, the ink cartridge 1 is in a slanted position. In Figure 10, the slant angle is approximately 10° , but it is to be understood that this is not a limiting aspect. In this non-limiting embodiment, the reflecting sites 4 of the four separate prisms 2 generate light signals which are beamed to the ink cartridge wall 5, and viewed by the user's eye 20 or detected electrically (via
10 detector 16), the tallest prism 2 generating the first detectible signal, the next tallest prism 2 generating the second detectible signal, and so forth. Due, at least in part, to the slanted position of the cartridge 1, by the time the fourth prism 2 generates a detectible signal, the ink cartridge 1 is still approximately half full.

15 By the time the ink reaches a level such that a full detectible light signal is generated by the "U" shaped prism 2", the ink is much closer to empty. With the ink cartridge 1 in a slanted position, the channel 12 in the "U" shaped prism 2" becomes empty before the notch 13, C. As previously described, this results in a weaker signal, at least until the notch 13, C is emptied of ink. Like the
20 embodiment of Figure 9, the second reflection site 4', which receives and reflects the full or partial light beam, may be surrounded by an air pocket such that the light beam may be reflected even when the reflection site 4' is below the ink level. When the ink depletes to a level such that the light beam passes through the notch 13, C, a full signal is then generated. It is to be understood
25 that when this last signal is detected by an electronic detector 16, a message may be generated by the printer 8 telling the user that the cartridge 1 is indeed close to empty.

Figure 11 depicts still another embodiment of a two segmented prism 2'''". In Figure 11, the two segmented prism 2''' includes the channel 12 (separating
30 the top side T into segments S1, S2) and the notch 13, C (partially separating the second segment S2 into opposed ends S2E1, S2E2), but is "L"-shaped rather than U-shaped. The light is first directed through one end E1 of the prism

2''' at the short side of the "L", reflecting off a first reflection site 4 and traveling along the top or long side T of the "L" through the channel 12, notch 13, C and portion 14 directly adjacent the notch 13, C, and to the other end E2 of the "L". The other end E2 of the prism 2''' includes two additional reflection sites 4', 4'', one 4' of which reflects the light 90° toward the other 4''. The other additional reflection site 4'' then reflects the light 90° (i.e., 180° from the light beam reflected from the first reflection site 4) such that it travels back toward the reflection site 4.

Like the embodiments of Figures 9 and 10, the second and third reflection sites 4', 4'', which receive and reflect the light beam, are each surrounded by an air pocket (not shown) provided by an extra layer of material of the prism 2''' a spaced distance from and surrounding the additional reflection sites 4', 4'', thus assuring that the reflection sites 4', 4'' reflect any light beam they receive, regardless of the ink level. The light is beamed back through the notch 13, C and channel 12 toward the first reflection site 4. In one embodiment, the first reflection site 4 is configured to receive all of the reflected light and to reflect the received light 90° (if the reflection site 4 is above the ink level) toward the bottom 10 of the ink cartridge 1 at the end E1 at which the light first entered the prism 2'''. It is believed that this configuration of the prism 2''' is designed with space and energy considerations in mind, specifically so that the LED 3 and the electrical detector 16 or viewing window 7 can be located near each other.

In a further embodiment (shown in Figure 11), the prism 2''' (and particularly the reflection site 4) may be configured so that the beam returning back through the top side T is broad enough such that part a portion of the beam is reflected by the first reflector site 4, and another portion of the beam is not reflected down by the first reflector site 4. The portion not reflected passes directly through the prism wall 17 (i.e., when ink is not blocking that portion of the wall 17) and out of the ink cartridge inner wall 5 to a viewing window 7 where it can be detected (e.g., electronically). It is to be understood that this configuration enables the level of ink in the cartridge 1 to be both electrically detectable and human viewable at different areas around the cartridge 1,

As such, the embodiments of Figures 10 and 11, like Figures 7A, 7E and 8, are capable of having a light signal (which is perpendicular to the original direction of the light beam and parallel to the bottom 10 of the ink cartridge 1) reflected across the ink pocket 6 and out the wall 5 of the ink cartridge 1, and
5 another light signal (which is parallel to the original direction of the light beam and perpendicular to the bottom 10 of the ink cartridge 1) reflected out the bottom 10 of the ink cartridge 1. Thus again, two separate light signals may be registered by electrical detection 16, the human eye 20, or a combination of the two at two different areas of the ink cartridge 1.

10 While several embodiments have been described in detail, it will be apparent to those skilled in the art that the disclosed embodiments may be modified. Therefore, the foregoing description is to be considered exemplary rather than limiting.

What is claimed is:

1. An ink cartridge (1) configured to hold an ink, the ink cartridge (1) comprising:
 - 5 a substantially hollow body (23) including an inner space (21) and a substantially continuous inner wall (5); and
an optical prism (2, 2'', 2''') in the inner space (21) of the body (23), disposed at a predetermined distance from the continuous inner wall (5) such that a prism wall (17) and the continuous inner wall (5) of the ink cartridge (1)
10 define an ink pocket (6), the optical prism (2, 2'', 2''') including at least one reflection site (4) formed at an angle configured to reflect light from a light source through the optical prism (2, 2'', 2''') at a predetermined height of the optical prism (2, 2'', 2''') relative to a bottom (10) of the hollow body (23);
wherein if the ink is present in the ink pocket (6) at a level below at least
15 a portion of the at least one reflection site (4), the ink does not block the light reflected off of the at least a portion of the at least one reflection site (4) from traveling across the ink pocket (6) at the predetermined height, such that the reflected light is externally detectable by electronic means (16).
- 20 2. The ink cartridge (1) of claim 1 wherein the prism (2, 2'', 2''') includes a plurality of separate reflection sites (4), each separate reflection site (4) being located at a different predetermined height of the optical prism (2, 2'', 2''') relative to the bottom (10), wherein each separate reflection site (4) generates a separate light reflection traveling through the optical prism (2, 2'',
25 2''') and across the ink pocket (6) at the predetermined height corresponding to the separate reflection site (4) from which the separate light reflection is generated if the ink in the ink pocket (6) does not block the separate light reflection from traveling at the corresponding predetermined height, and wherein each of the separate light reflections at the corresponding predetermined height
30 is externally detectable by electronic means (16) as a separate light signal.

3. The ink cartridge (1) of any of claims 1 and 2, further comprising a plurality of separate reflection sites (4) configured to reflect light at the predetermined height, wherein each of the separate reflection sites (4) generates a separate light reflection traveling through the optical prism (2, 2", 2''') and across the ink pocket (6) at the predetermined height in a different lateral position than each of the other separate light reflections traveling at the predetermined height if the ink in the ink pocket (6) does not block the separate light reflections from traveling through the ink pocket (6) at the predetermined height, and wherein the separate light reflections are externally detectable by electronic means (16) as separate light signals.

4. The ink cartridge (1) of any of claims 1 through 3 wherein the body (23) is positioned such that the ink does not block the at least one light reflection from traveling across the ink pocket (6) at the predetermined height when at least a portion of the ink is still present in the body (23).

5. The ink cartridge (1) of any of claims 1 through 4, wherein the continuous inner wall (5) includes at least one additional reflection site (4') on a portion thereof, the additional reflection site (4') i) further defining the ink pocket (6), ii) positioned at the predetermined height and iii) configured to receive and reflect the light reflected by the at least one reflection site (4) of the optical prism (2, 2", 2''') if the ink in the ink pocket (6) does not block the light reflected by the at least one reflection site (4) from traveling across the ink pocket (6) at the predetermined height.

25

6. The ink cartridge (1) of any of claims 1 through 5, further comprising:

a second reflection site (4) of the optical prism (2, 2", 2''') positioned at a second predetermined height that is different than the predetermined height;

30 a third reflection site (4') of the optical prism (2, 2", 2''') configured to receive light reflected from the second reflection site (4); and

a notch (11) formed in the prism wall (17) facing the ink pocket (6), the notch (11) being cut out of an area of the prism (2, 2'', 2''') completely crossing a light path that extends from the third reflection site (4') to the bottom (10) of the hollow body (23), thereby forming a recess (R) in the optical prism (2, 2'', 2''')
5 which increases a volume of the ink pocket (6);

wherein the light travels on the light path from the third reflection site (4') across the notch (11) and out the bottom (10) if ink is absent from the recess (R).

10 7. The ink cartridge (1) of any of claims 1 through 6, further comprising a notch (11) formed in a prism wall (24) opposed to the prism wall (17) facing the ink pocket (6), the notch (11) being cut out of an area of the prism (2, 2'', 2''') completely crossing a light path that extends from the bottom (10) of the hollow body (23) to the at least one reflection site (4), thereby
15 forming a recess (R) in the optical prism (2, 2'', 2''') that increases the volume of the inner space (21), wherein light is prevented from entering the prism (2, 2'', 2''') if ink is present in the recess (R).

20 8. The ink cartridge (1) of any of claims 1 through 4 wherein the prism (2, 2'', 2''') includes two discontinuous but optically aligned sections (S1, S2) and a channel (12) located between the two sections (S1, S2), and wherein if the ink is absent from the channel (12), the light travels on a light path from a first (S1) of the two sections (S1, S2) across the channel (12) and into a second (S2) of the two sections (S1, S2).

25

9. The ink cartridge (1) of claim 8 wherein the optical prism (2, 2'', 2''') further includes a notch (13) formed at an area of the prism (2, 2'', 2''') partially crossing the light path in the second section (S2) such that the notch (13) partially divides the second section (S2) into two opposed end regions (S2E1, S2E2), wherein the notch (13) forms an other ink channel (C), and
30 wherein, after the light travels on the light path from the first section (S1) across the channel (12) and into a first opposed end region (S2E1) of the second

section (S2), a part of the light travels through the first opposed end region (S2E1) across the other ink channel (C) and into a second opposed end region (S2E2) of the second section (S2) if ink is absent from the other channel (C).

5 10. The ink cartridge (1) of claim 9 wherein the at least one reflection site (4) is configured to direct the light through the channel (12) and the other channel (C), and wherein the prism (2, 2'', 2''') further includes at least two additional reflection sites (4', 4''), a first (4') of the at least two additional reflection sites (4', 4'') configured to i) receive the light after it passes through
10 the channel (12) and the other channel (C), and ii) transmit the light to a second (4'') of the at least two additional reflection sites (4', 4''), and the second (4'') of the at least two additional reflection sites (4', 4'') configured to transmit the light back through the other channel (C) and the channel (12) to the at least one reflection site (4), which is configured such that i) a portion of the light that is
15 reflected back contacts the at least one reflection site (4) and is directed out the bottom (10) of the hollow body (23), and ii) an other portion of the light that is reflected back does not contact the at least one reflection site (4) and travels directly out the prism wall (17) facing the ink pocket (6), thus dividing the light to form two electronically detectable signals emitted from separate parts of the ink
20 cartridge (1).

 11. The ink cartridge (1) of any of claims 1 through 7, further comprising a second optical prism (2'') positioned a spaced distance from a prism wall (24) opposed to the prism wall (17) facing the ink pocket (6), the
25 second optical prism (2'') including:
 a first section (S1) having a first reflection site (4);
 a second section (S2) that is discontinuous from and optically aligned with the first section (S1), the second section (S2) having a second reflection site (4') configured to receive light reflected from the first reflection site (4) and
30 direct the light out of the bottom (10) of the hollow body (23); and

a channel (12) located between the first and second sections (S1, S2), wherein if the ink is absent from the channel (12), the light travels on the light path from the first section (S1) into the second section (S2).

- 5 12. The ink cartridge (1) of claim 1 wherein the optical prism (2, 2'', 2''') includes two reflection sites (4, 4''), one (4) at the predetermined height and an other (4'') at a second predetermined height, and wherein the ink cartridge (1) further comprises an additional optical prism (2') positioned adjacent to the optical prism (2, 2'', 2''') to define a second ink pocket (6') between the optical prism (2, 2'', 2''') and the additional optical prism (2'), the additional optical prism (2') including at least one reflection site (4') positioned at the second predetermined height of the other (4'') of the two reflection sites (4, 4'') of the optical prism (2, 2'', 2''') and configured to receive and reflect a light reflection generated by the other (4'') of the two reflection sites (4, 4'') if the ink in the second ink pocket (6') does not block the light reflection from traveling across the second ink pocket (6').
- 10
- 15

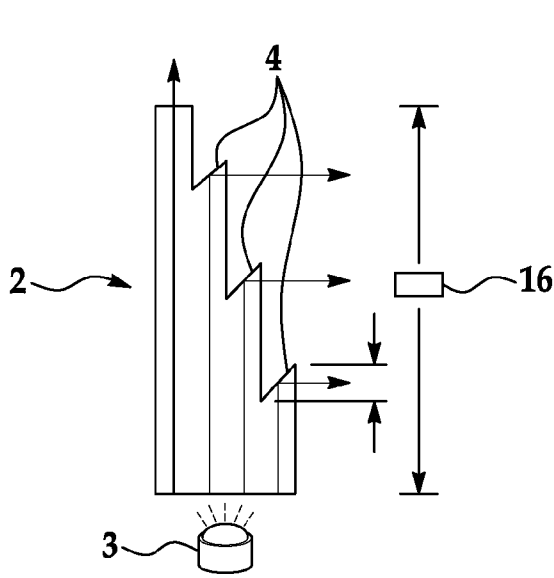
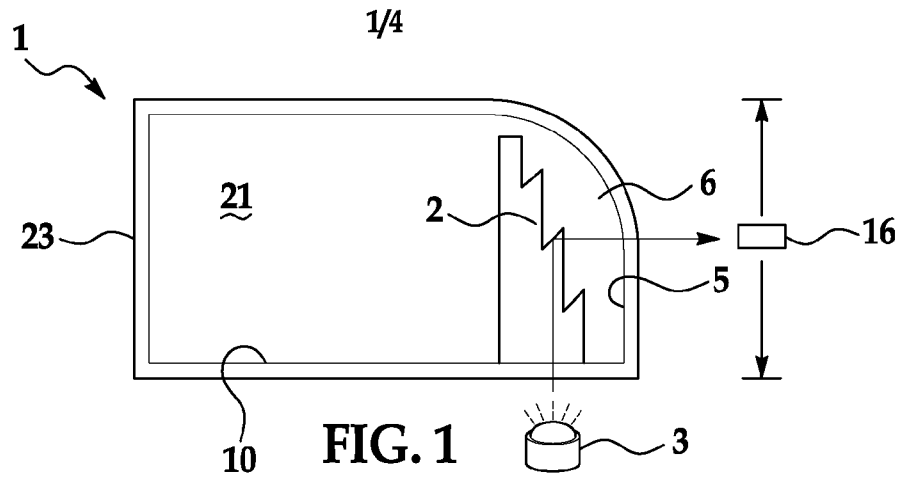

FIG. 2A

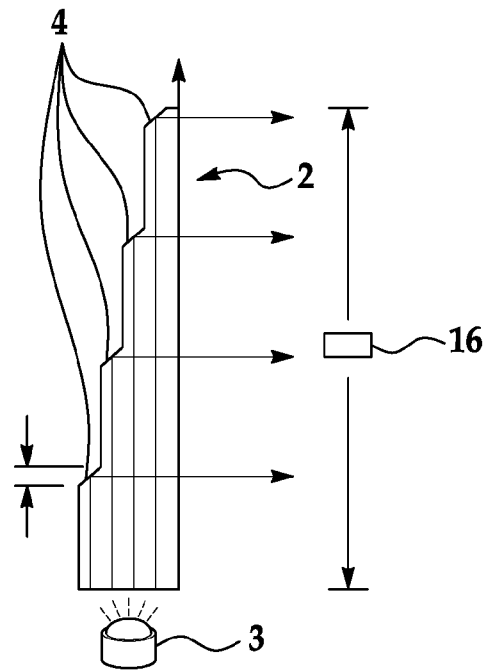

FIG. 2B

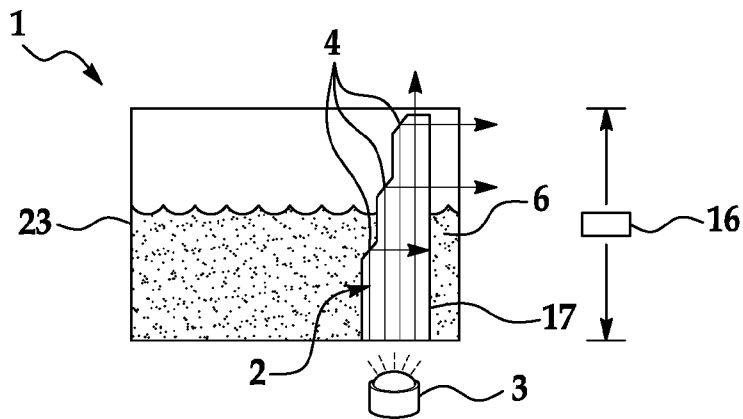

FIG. 3

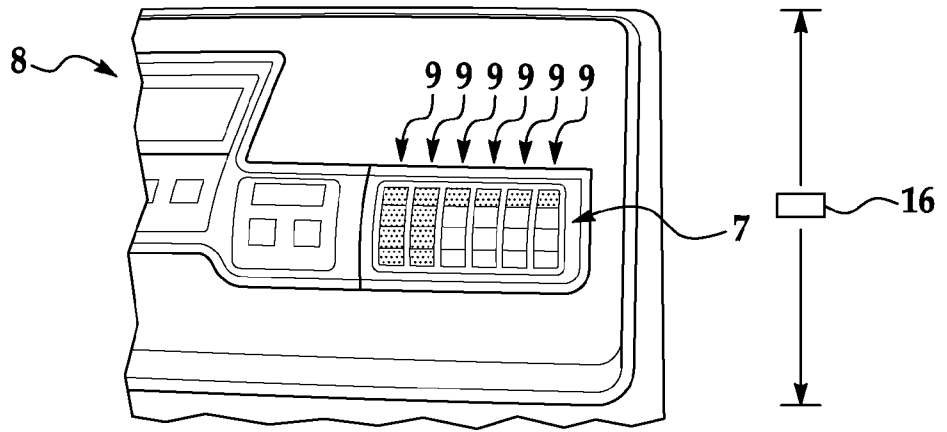

FIG. 4

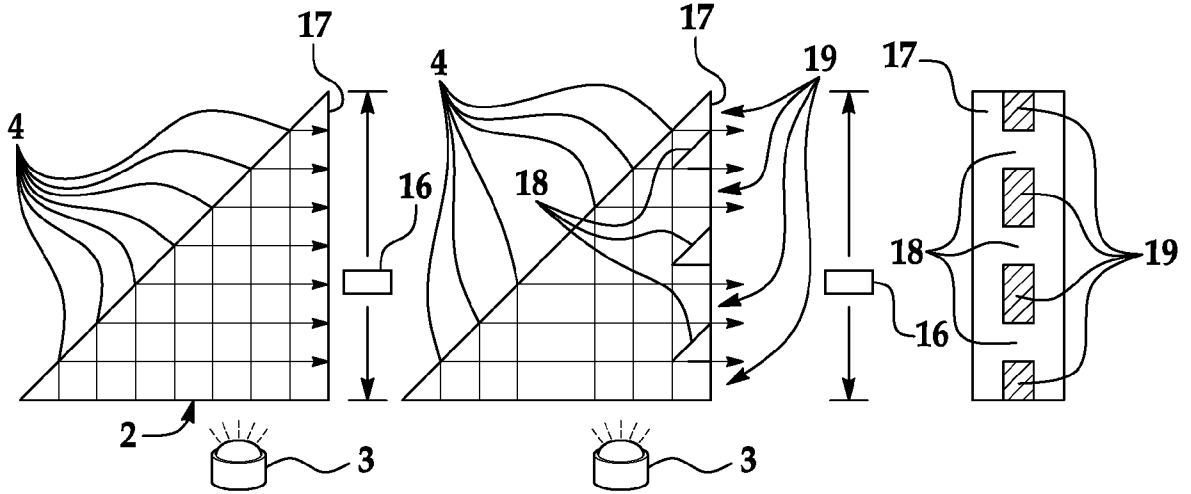

FIG. 5A

FIG. 5B

FIG. 5C

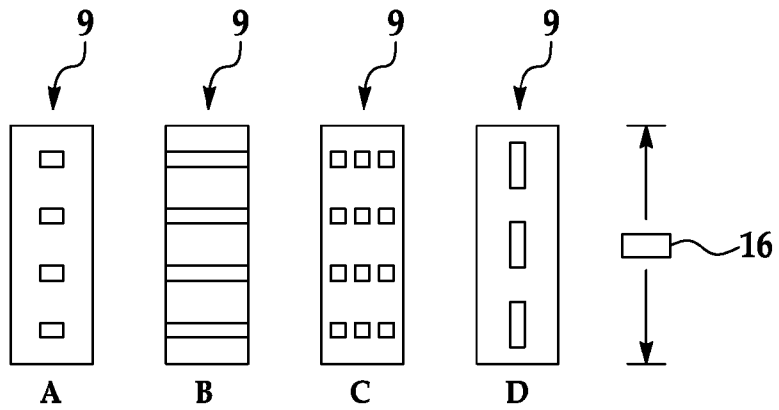

FIG. 6

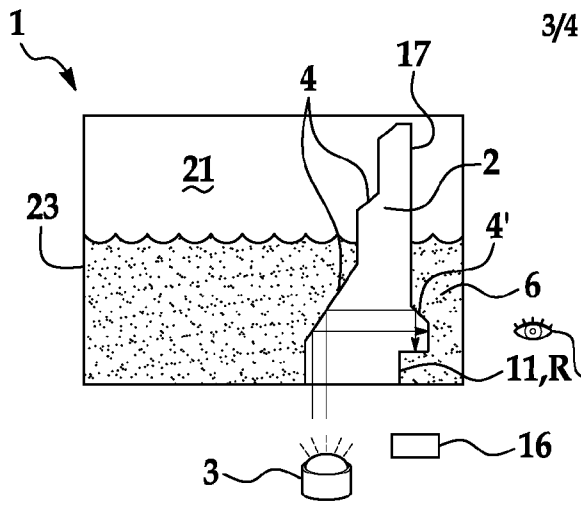

FIG. 7A

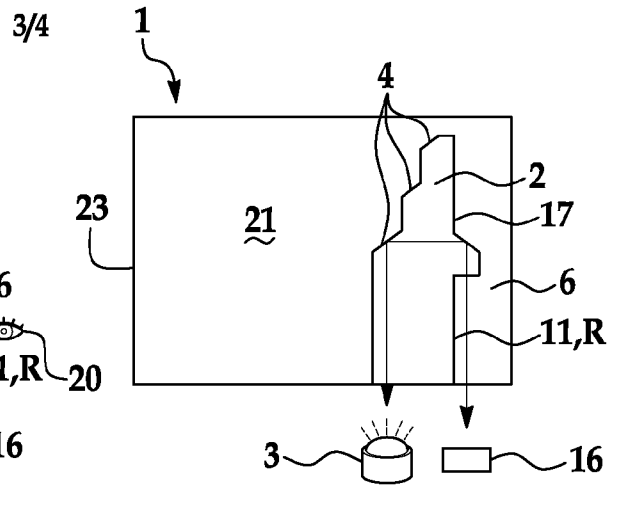

FIG. 7B

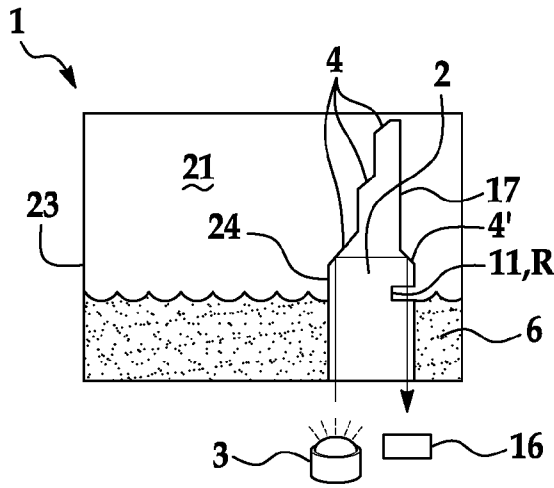

FIG. 7C

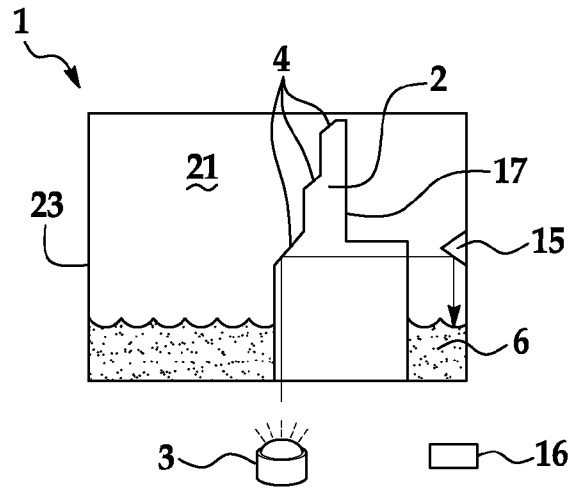

FIG. 7D

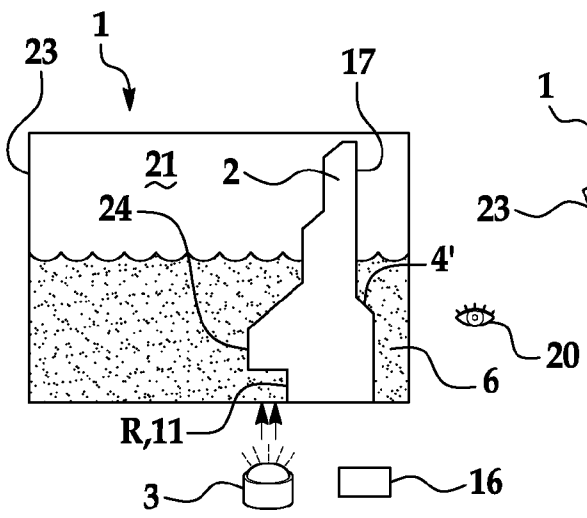

FIG. 7E

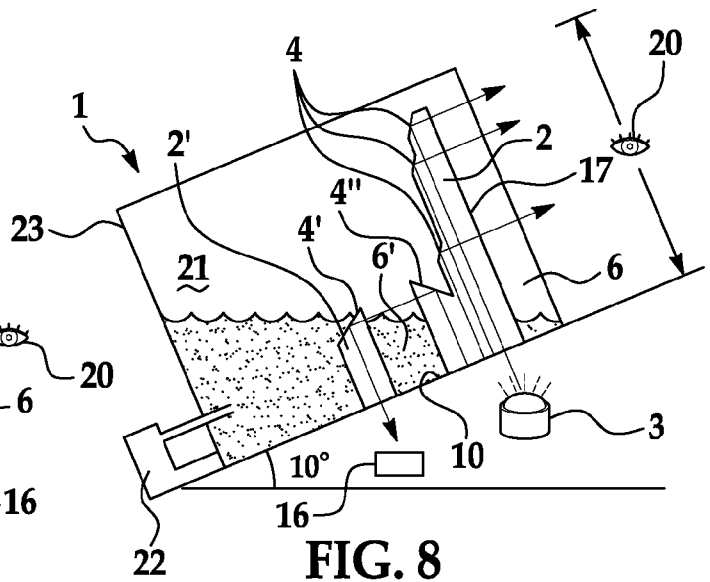

FIG. 8

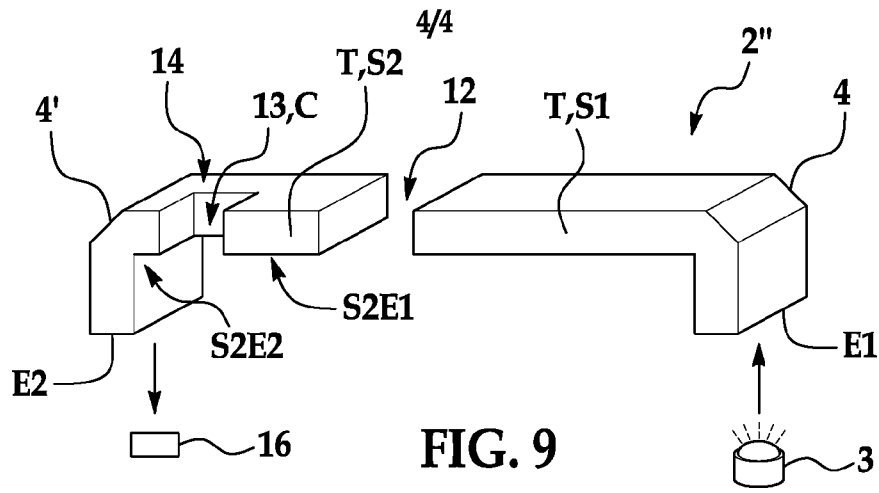

FIG. 9

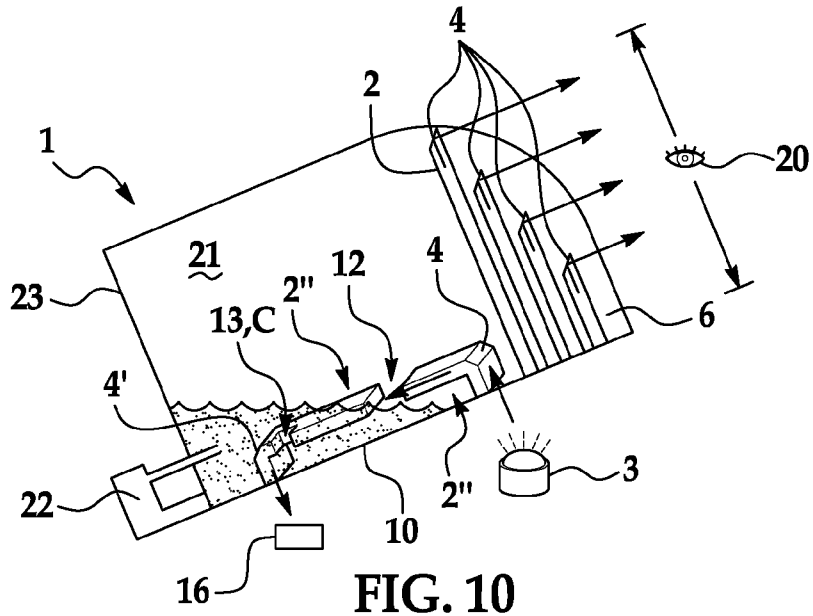

FIG. 10

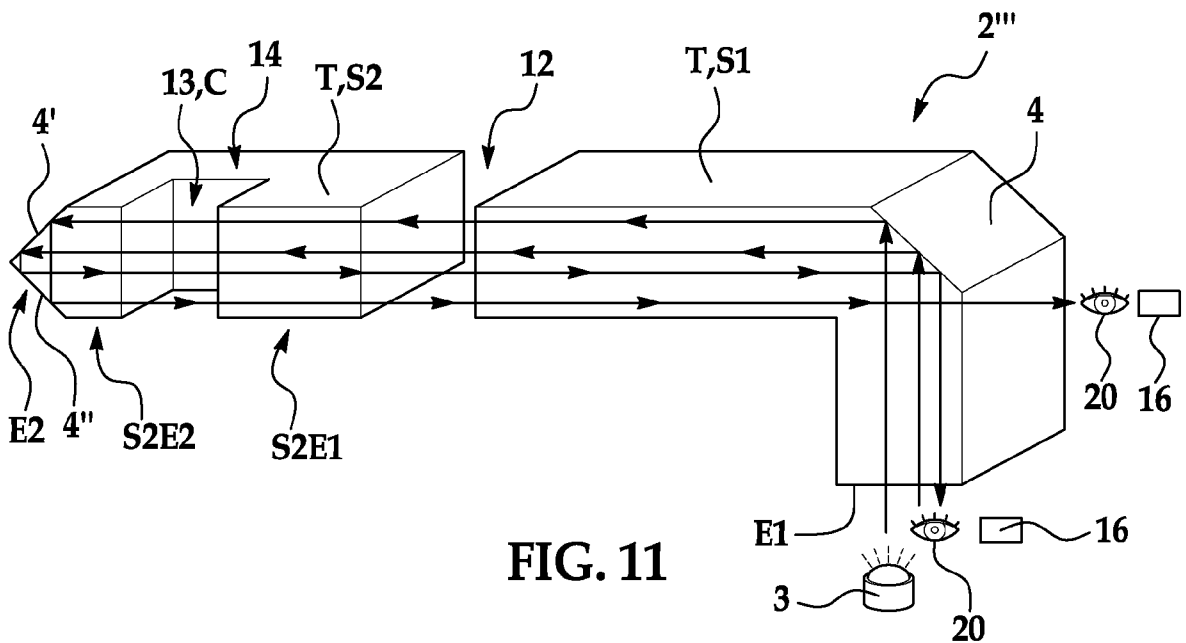

FIG. 11