

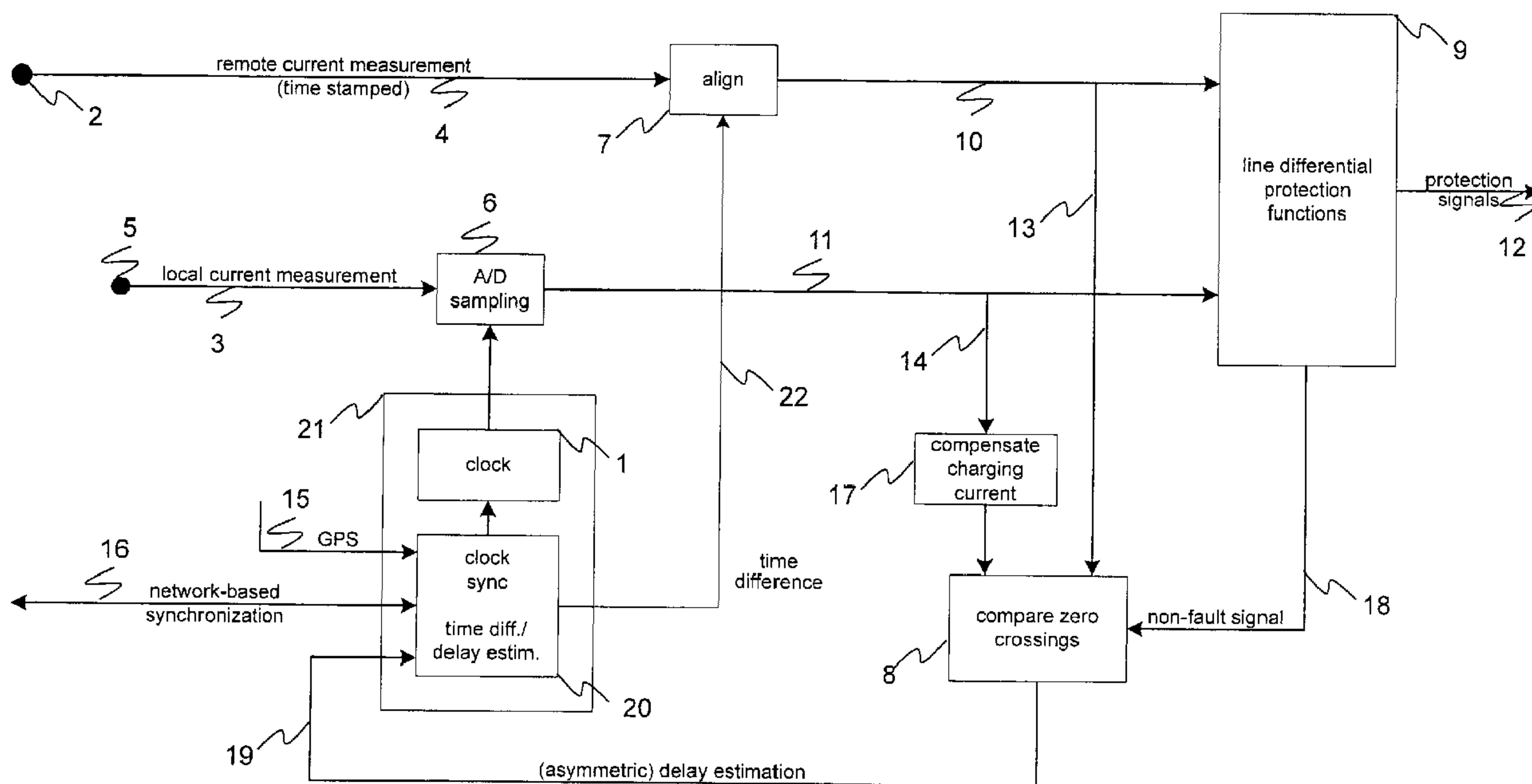

(22) **Date de dépôt/Filing Date:** 2013/07/24  
 (41) **Mise à la disp. pub./Open to Public Insp.:** 2014/01/31  
 (45) **Date de délivrance/Issue Date:** 2016/05/03  
 (30) **Priorité/Priority:** 2012/07/31 (EP12178590.1)

(51) **Cl.Int./Int.Cl. H02J 13/00** (2006.01),  
**H04B 3/54** (2006.01)  
 (72) **Inventeur/Inventor:**  
DZUNG, DACFEY, CH  
 (73) **Propriétaire/Owner:**  
ABB RESEARCH LTD, CH  
 (74) **Agent:** NORTON ROSE FULBRIGHT CANADA  
LLP/S.E.N.C.R.L., S.R.L.

(54) **Titre : SYNCHRONISATION D'HORLOGE POUR PROTECTION DIFFERENTIELLE DE LIGNE**  
 (54) **Title: CLOCK SYNCHRONIZATION FOR LINE DIFFERENTIAL PROTECTION**



(57) **Abrégé/Abstract:**

A method for synchronization of two stationary clocks located respectively at a first and a second end of an AC power line. The two clocks are initially synchronized to within a period of a line frequency of the power line. A first representation of an oscillating power line quantity is produced by measuring the power line quantity at the first end of the power line and time-stamping the first representation by the first clock. A second representation of the oscillating power line quantity is produced by measuring the power line quantity at the second end of the power line and time-stamping the second representation by the second clock. The first and second representations are compared to determine a clock offset between the first and second clocks. One or both of the first and second clock or at least the first clock is then adjusted to reduce the clock offset.

**ABSTRACT**

A method for synchronization of two stationary clocks located respectively at a first and a second end of an AC power line. The two clocks are initially synchronized to within a  
5 period of a line frequency of the power line. A first representation of an oscillating power line quantity is produced by measuring the power line quantity at the first end of the power line and time-stamping the first representation by the first clock. A second representation of the oscillating power line quantity is produced by measuring the power line quantity at the second end of the power line and time-stamping the second representation by the  
10 second clock. The first and second representations are compared to determine a clock offset between the first and second clocks. One or both of the first and second clock or at least the first clock is then adjusted to reduce the clock offset.

## DESCRIPTION

### CLOCK SYNCHRONIZATION FOR LINE DIFFERENTIAL PROTECTION

5

#### FIELD OF THE INVENTION

The invention relates to the field of time synchronization between two geographically separated stationary clocks, in particular clocks at two ends of a power transmission line.

10 

#### BACKGROUND OF THE INVENTION

Power transmission lines are a crucial part of any electrical distribution system, as they provide a path to transfer power between generation and consumer. Power transmission lines are closely interconnected for a reliable operation. Economic and environmental requirements lead to operation of power transmission lines close to their operating limits.

15 

Any fault will cascade into a system wide disturbance causing widespread outages for a tightly interconnected system operating close to its limits. Therefore, transmission protection systems are set up to identify faults. The main task for the transmission line protection lies in reliably detecting faults compromising the security of the system.

20 

For differential protection systems of power transmission lines, protection devices at both ends of the transmission line measure a representation of a power line quantity such as current and compare the measured quantity of both ends. Under normal fault-free conditions, the quantity is the same at both ends. Deviating measurements indicate a fault on the transmission line and trigger protection actions such as opening a circuit breaker. A prerequisite for the laid out differential protection system is precise synchronization of the

25 

measurement devices on both ends.

30 

For synchronizing, distributed protection device clocks are aligned to a master clock of some sort. In order to do so, a common clock source sends a synchronization signal e.g. through a communication network. Each clock of the distributed protection devices receives the synchronization signal and performs necessary adjustments accordingly. Generally synchronization signals are sent from a global positioning system (GPS) satellite

clock via direct or indirect satellite communication, or from a network master clock via a communication network to which the protection devices are connected.

However, synchronization with a master clock may neither be always reliable nor cost effective. Reception of a GPS based synchronization signal may be costly and even  
5 unreliable, as communication with the satellite may be interrupted e.g. by radio interference or severe weather conditions impairing signal propagation. In addition, network-based synchronization assumes communication delays between clocks to be symmetric, i.e. equal in both directions, an assumption which is not generally guaranteed.

## 10 DESCRIPTION OF THE INVENTION

It is therefore an objective of the invention to increase reliability of protection systems for a power transmission line, in particular to improve clock synchronization of such a system.

This objective is achieved by a method and an arrangement for synchronizing clocks  
15 located at opposite ends of a power line.

According to the invention, a first and a second clock located respectively at a first and a second end of an AC power line are aligned according to an oscillating power line quantity  $q$  such as a current, wherein the two clocks are initially synchronized to be within a period of a frequency of the power line quantity  $q$ . In order to synchronize the clocks a  
20 first representation such as a waveform of an oscillating power line quantity  $q$  is produced by measuring the power line quantity at the first end of the power line. In particular the quantity  $q$  may be measured or recorded with a sufficient number of samples  $q(t_i)$  within an oscillation period such that the oscillating quantity is represented properly and may be compared with other measurements at different points in time or space. As important as the  
25 value or values of the first representation is the time it was recorded or measured, thus, the samples taken get time stamped by the first clock located at the first end of the AC power line. This actually allows keeping track of the timing of the first clock.

For synchronization, measurement of the same oscillating power line quantity  $q$  is needed also from the second end of the power line. Therefore, a second representation of  
30 the oscillating power line quantity is measured at the second end of the power line. In order

to be able to make a correlation between clock and power line quantity, the second representation is time stamped by the second clock.

In a further step the first and second representation may be sent to either one or both of the two ends of the power line or any other common location for comparing the first and the second representation. Comparison may be performed by aligning the representations and determining a clock offset between the first and the second clock using the respective time-stamps. In other words, the clock offset is assumed to correspond to the time interval by which one of the representations has to be shifted in order to match or overlap the other representation of the oscillating property.

Eventually, an adjustment is carried out to reduce the determined clock offset, wherein one or both of the first and second clocks are set or reset based on the comparison and the calculated offset.

In a preferred variant of the invention, the first representation or a copy of it is transmitted or sent via a communication link to the second end of the power line and only the second clock is adjusted by the determined clock offset. This way the method may be carried out quickly and easily as only one message needs to be sent and only one clock needs to be adjusted.

In an advantageous embodiment of the invention, the clock offset is determined by calculating a difference between a first-clock timestamp  $t_1$  of a zero crossing of the first representation and a second-clock timestamp  $t_2$  of a zero crossing of the second representation. However, the clock offset may also be determined by calculating a correlation function between the two representations involving the entire waveform. This approach is more complex but also more reliable, thus more robust to noisy measurements.

However, in some cases there might be a noticeable phase difference between the oscillating power line quantity  $q$  at the first end and at the second end of the power line due to line charging current effects, in particular with long lines during light load conditions. Such an inherent, clock-sync-independent phase difference needs to be compensated in order to achieve high accuracy clock synchronization, which includes calculating the phase difference, and adjusting the previously determined clock offset by adding or subtracting a time delay corresponding to the calculated phase difference.

Anyhow, a prerequisite to carry out the method according to the current invention is the initial fault-free operation of the power transmission line. Therefore, it is crucial for a Line

Differential Protection function to signal fault-free operation of the power line before the method and eventually the alignment of the clocks may be carried out. However, if operation is not fault-free, the clock adjustment may not proceed until a fault-free operation is restored and signaled.

5 The method according to the invention is particularly useful as a fine adjustment or high precision synchronization as other synchronization methods may experience inherent time delays or shifts. In particular, in network-based time synchronization an underlying assumption is symmetric inter-node communication. However, in modern communication networks this basic assumption may not be valid. This is particularly important where a synchronization message inter-node travel time exceeds the symmetric delay calculated  
10 previously and used to compensate a residual clock offset at the receiving node.

Therefore, the current invention is particularly useful, where prior to executing the method the first and the second clock are synchronized based on a symmetric communication delay established for a fully operational network-based time  
15 synchronization such as Network Time Protocol (NTP) or Precision Time Protocol (PTP) of a communication link between the first and the second end of the power line. The current invention takes into account any asymmetric time delays within a network-based time synchronization method and provides a high precision synchronization.

Furthermore, the method according to the current invention is useful in case of a global  
20 positioning system (GPS) based time synchronization, where the GPS signal may be lost at times. Thus, the invention provides synchronization, wherein prior to executing the method of the current invention the first and the second clock are synchronized based on a GPS signal, and wherein following a loss of the GPS signal, the synchronization of the clocks is maintained for a holdover period exceeding 30 seconds.

25 In accordance with a first broad aspect, there is therefore provided a method of synchronizing a first and a second clock located respectively at a first and a second end of an AC power line, comprising producing a first representation of an oscillating power line quantity  $q$  by measuring the power line quantity at the first end of the power line, and time-stamping the first representation by the first clock, producing a second representation of  
30 the oscillating power line quantity  $q$  by measuring the power line quantity at the second end of the power line, and time-stamping the second representation by the second clock, comparing the first and the second representation to determine a clock offset between the

4a

first and the second clock, and adjusting one or both of the first and second clock to reduce the determined clock offset, the method further comprising checking whether the determined clock offset is within a predetermined limit, or whether a Line Differential Protection function signals fault-free operation of the power line.

- 5       The present invention also relates to an arrangement for synchronizing a first and a second clock located respectively at a first and a second end of a power line, i.e., the arrangement including a recorder for measuring a first representation of an oscillating power line quantity  $q$  such as current at a first end of the power line and for time-stamping the first representation by the first clock, a receiver for receiving a second representation of
- 10 the oscillating power line quantity  $q$  measured at the second end of the power line and time-stamped by the second clock, a comparator for comparing the first and the second representation to determine a clock offset between the first and the second clock, and a clock adjuster for adjusting the first clock to reduce the determined clock offset. The arrangement is adapted to check whether the determined clock offset is within a
- 15 predetermined limit, or whether a Line Differential Protection function signals fault-free operation of the power line.

Anyhow, given an initial fault-free state of the power transmission line the current invention synchronizes clocks located at ends of a power transmission line based on a measured and time-stamped representation with high precision and reliability. This way the current invention may be used as a stand-alone or add-on synchronization method  
5 overcoming shortcomings of other i.e., network or GPS based, synchronization methods.

#### BRIEF DESCRIPTION OF THE DRAWINGS

The subject matter of the invention will be explained in more detail in the following text with reference to preferred exemplary embodiments which are illustrated in the attached  
10 drawings, in which:

Fig.1 shows a schematic overview of a method to synchronize clocks located at two ends of a power transmission line and used for differential protection of said power transmission line, and

Fig.2 depicts two representations of an oscillating power line quantity as recorded with  
15 two clocks experiencing a slight offset.

The reference symbols used in the drawings, and their meanings, are listed in summary form in the list of designations. In principle, identical parts are provided with the same reference symbols in the figures.

#### 20 DETAILED DESCRIPTION OF PREFERRED EMBODIMENTS

Fig.1 shows a schematic overview of the first end of a line differential protection system for a power transmission line including a first clock 1 and a second clock 2 located at each end of a power transmission line. A first representation 3 and a second representation 4 of an oscillating power line quantity  $q$  are produced at a first recorder 5 at a first local  
25 location and a second recorder at a remote second location. The recorder 5 measures e.g. a current multiple times within a period of oscillation in order to produce a representation 3 suitable for synchronization. The first representation 3 is time stamped by the first clock 1 using a sampling unit 6.

The time stamped representations 3, 4 are forwarded to a line differential protection  
30 function 9 e.g. via network links 10, 11 in order to check the line status and detect any faults of the power transmission line. The line differential protection function 9 generates a

signal 18 containing the status of the power transmission line and forwards the signal to respective recipients through a network.

The time stamped representation 3, 4 are further forwarded via network links 13, 14 for further processing to a comparator 8, where any offset or a asymmetric delay estimation is  
5 calculated. Any phase difference between the oscillating power line quantity at the first end and at the second end of the power line due to line charging current effects may be previously compensated for by a phase compensator 17.

In this embodiment of the invention, the first clock 1 is generally synchronized via a GPS signal 15 or a network-based synchronization signal 16. However, in case there is a  
10 loss of the GPS signal 15 the invention provides a method to synchronize the clocks 1, 2 during the loss of the GPS signal 15. In addition, the current invention provides a system and a method to perform a higher precision synchronization of clocks 1, 2 in case of any asymmetry in the network synchronization signal 16.

After receiving the first and second representation 3, 4 the comparator 8 calculates an  
15 offset 19. In case the comparator 8 receives a non-fault status signal 18 from the line differential protection function 9, the offset 19 is forwarded to a synchronization unit 20 of a timing unit 21 comprised of the synchronization unit 20 and e.g. the first clock 1. The synchronization unit 20 then resets or aligns the first clock and/or may send the respective offset 22 for partial aligning to the receiver 7 for adjusting the time stamps of the remote  
20 representation 4.

Fig.2 depicts a shift 23 observed at a state of the art line differential protection device. The plot shows a local signal or first representation 3 and a remote signal or second representation 4 of a line current with amplitude at y-axis 24 as a function of, respectively, local and remote time reported on x-axis 25. The observed shift 23 is due to a clock offset  
25 between local and remote clocks, and may also include a phase difference due to line charging current effects. The present invention exploits this observed shift to correct any clock offset, such as arising e.g. due to asymmetric communication time delays within a network-based time synchronization method, and thus provides a high precision synchronization.

## LIST OF DESIGNATIONS

	1	First clock
	2	Second clock
5	3	First representation
	4	Second representation
	5	Recorder
	6	Sampling unit
	7	Receiver
10	8	Comparator
	9	Line differential protection function
	10	Network link
	11	Network link
	12	Line protection signal
15	13	GPS signal
	14	Network synchronization signal
	17	Phase compensator
	18	Status signal
	19	Offset
20	20	Synchronization unit
	21	Timing unit
	22	Offset
	23	Asymmetry
	24	Y-axis
25	25	X-axis

## PATENT CLAIMS

1. A method of synchronizing a first and a second clock located respectively at a first and  
5 a second end of an AC power line, comprising
  - producing a first representation of an oscillating power line quantity  $q$  by measuring the power line quantity at the first end of the power line, and time-stamping the first representation by the first clock,
  - producing a second representation of the oscillating power line quantity  $q$  by  
10 measuring the power line quantity at the second end of the power line, and time-stamping the second representation by the second clock,
  - comparing the first and the second representation to determine a clock offset between the first and the second clock, and
  - adjusting one or both of the first and second clock to reduce the determined clock  
15 offset,wherein the method further comprises: checking whether the determined clock offset is within a predetermined limit, or whether a Line Differential Protection function signals fault-free operation of the power line.
- 20 2. The method of claim 1, comprising
  - transmitting the first representation to the second end of the power line, and
  - adjusting the second clock by the determined clock offset.
3. The method of claim 1, the clock offset determination comprising  
25
  - calculating a difference between a timestamp  $t_1$  of a zero crossing of the first representation and a timestamp  $t_2$  of a zero crossing of the second representation, or
  - calculating a correlation function between the two representations and determining a location of a peak of the correlation function.
- 30 4. The method of claim 1, the clock offset determination comprising
  - compensating a phase difference between the oscillating power line quantity  $q$  at the first end and at the second end of the power line.

5. A use of the method of one of claims 1 to 4, wherein the first and the second clock are synchronized based on a symmetric communication delay of a communication link between the first and the second end of the power line, and wherein any residual clock offset between the first and second clock is reduced by way of the method.

5

6. A use of the method of one of claims 1 to 4, wherein the first and the second clock are synchronized based on a GPS signal, and wherein following a loss of the GPS signal, the synchronization of the clocks is maintained by way of the method.

10 7. An arrangement for synchronizing a first and a second clock located respectively at a first and a second end of a power line, including

- a recorder for measuring a first representation of an oscillating power line quantity  $q$  at a first end of the power line and for time-stamping the first representation by the first clock, and

15 - a receiver for receiving a second representation of the oscillating power line quantity  $q$  measured at the second end of the power line and time-stamped by the second clock,

- a comparator for comparing the first and the second representation to determine a clock offset between the first and the second clock, and

20 - a clock adjuster for adjusting the first clock to reduce the determined clock offset, wherein the arrangement is adapted to check whether the determined clock offset is within a predetermined limit, or whether a Line Differential Protection function signals fault-free operation of the power line.

25

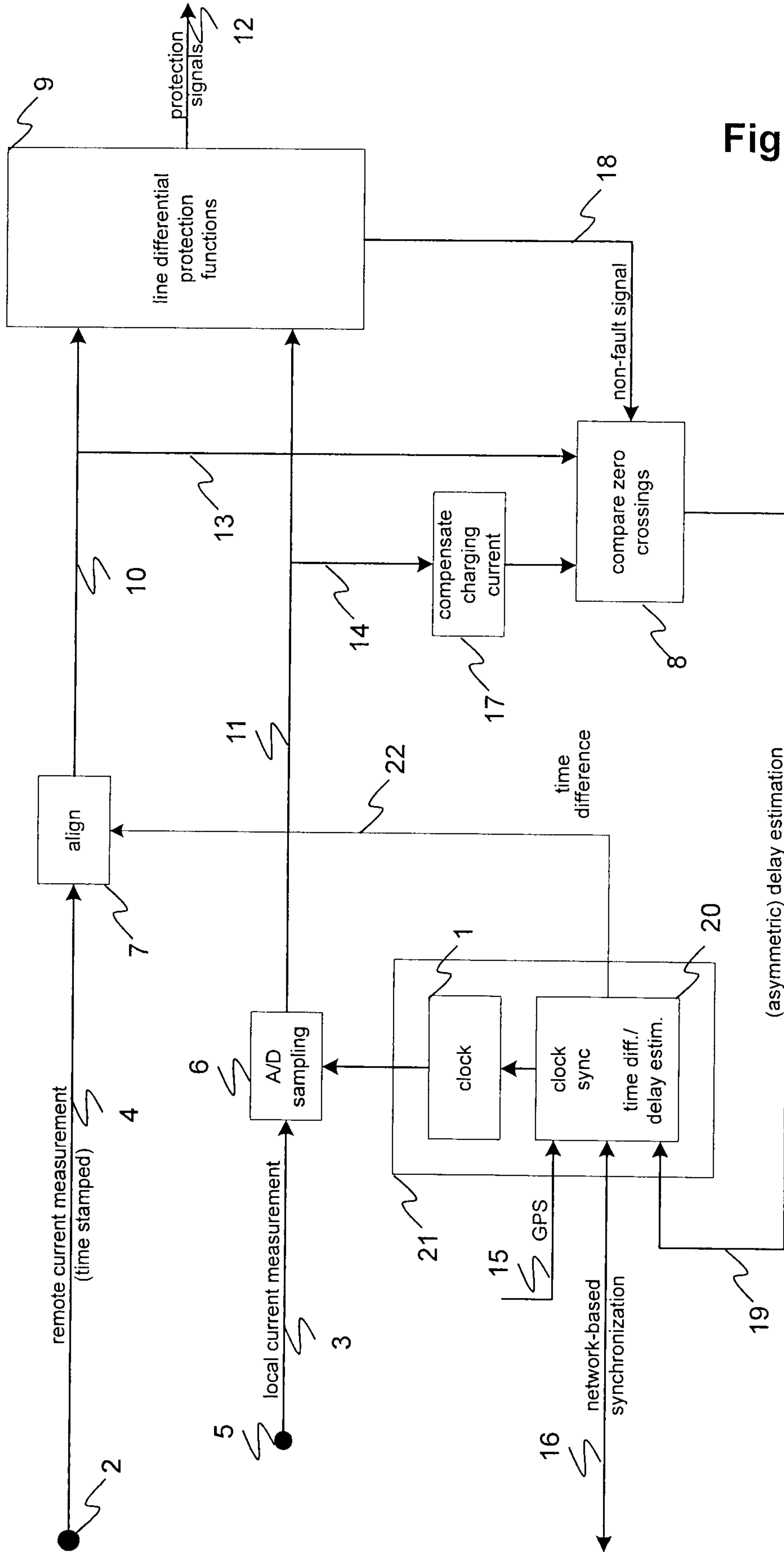

Fig. 1

2/2

Fig. 2

