



- (51) **International Patent Classification:**
B01J 19/00 (2006.01) *F28F 1/40* (2006.01)
B01J 19/24 (2006.01) *B01J 19/18* (2006.01)
BOW 9/00 (2006.01)
- (21) **International Application Number:**
PCT/GB20 12/053 111
- (22) **International Filing Date:**
12 December 2012 (12. 12.2012)
- (25) **Filing Language:** English
- (26) **Publication Language:** English
- (30) **Priority Data:**
1121401.2 13 December 2011 (13. 12.2011) GB
- (71) **Applicant (for all designated States except US):** **HERIOT WATT UNIVERSITY** [GB/GB]; Riccarton, Edinburgh Lothian EH14 4AS (GB).
- (72) **Inventors; and**
(71) **Applicants (for US only):** **NI, Xiongwei** [GB/GB]; 12 Craighleith Avenue North, Edinburgh Lothian EH4 3LG (GB). **CALLAHAN, Craig James** [GB/GB]; Flat 3, 9 The Mailings, Falkirk FK1 5BX (GB).

- (74) **Agent:** **LAWRIE IP LTD;** 272 Bath Street, Glasgow Strathclyde G2 4JR (GB).
- (81) **Designated States (unless otherwise indicated, for every kind of national protection available):** AE, AG, AL, AM, AO, AT, AU, AZ, BA, BB, BG, BH, BN, BR, BW, BY, BZ, CA, CH, CL, CN, CO, CR, CU, CZ, DE, DK, DM, DO, DZ, EC, EE, EG, ES, FI, GB, GD, GE, GH, GM, GT, HN, HR, HU, ID, IL, IN, IS, JP, KE, KG, KM, KN, KP, KR, KZ, LA, LC, LK, LR, LS, LT, LU, LY, MA, MD, ME, MG, MK, MN, MW, MX, MY, MZ, NA, NG, NI, NO, NZ, OM, PA, PE, PG, PH, PL, PT, QA, RO, RS, RU, RW, SC, SD, SE, SG, SK, SL, SM, ST, SV, SY, TH, TJ, TM, TN, TR, TT, TZ, UA, UG, US, UZ, VC, VN, ZA, ZM, ZW.
- (84) **Designated States (unless otherwise indicated, for every kind of regional protection available):** ARIPO (BW, GH, GM, KE, LR, LS, MW, MZ, NA, RW, SD, SL, SZ, TZ, UG, ZM, ZW), Eurasian (AM, AZ, BY, KG, KZ, RU, TJ, TM), European (AL, AT, BE, BG, CH, CY, CZ, DE, DK, EE, ES, FI, FR, GB, GR, HR, HU, IE, IS, IT, LT, LU, LV, MC, MK, MT, NL, NO, PL, PT, RO, RS, SE, SI, SK, SM, TR), OAPI (BF, BJ, CF, CG, CI, CM, GA, GN, GQ, GW, ML, MR, NE, SN, TD, TG).

[Continued on nextpage]

(54) **Title:** DEVICE FOR INDUCING NUCLEATION

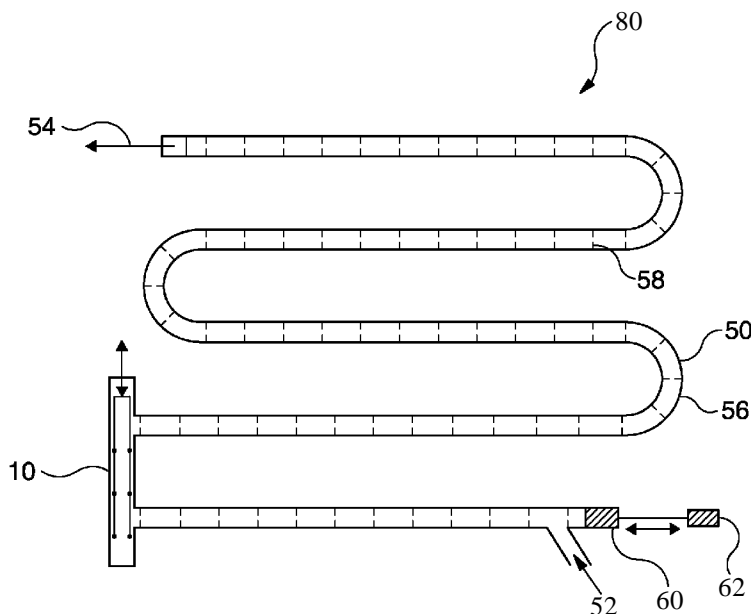

Figure 2

(57) **Abstract:** Described is a device for inducing crystal nucleation in a crystalliser. The device comprises a vessel for fluid and a surface abrad-er, wherein the surface abrad-er is configured to abrade a surface within the vessel to induce crystal nucleation. The friction of the abrad-er against the surface within the vessel creates nano-sized particulates which induce crystal nucleation. Crystal growth can then take place in the crystalliser. Also described is a crystallisation ap- paratus comprising the device and a crystallisa- tion process using the device or similar. The device is significantly cheaper and more reliable than known ultrasound devices and facilitates the separation of crystal nucleation and crystal growth. The device also enables the avoidance of the use of seeding as a source of secondary nucleation.

WO 2013/088145 A1

Published:

— with international search report (Art. 21(3))

— before the expiration of the time limit for amending the claims and to be republished in the event of receipt of amendments (Rule 48.2(h))

DEVICE FOR INDUCING NUCLEATION

Field of Invention

This invention relates to a device for inducing nucleation, a related
5 process and a crystallisation apparatus.

Background Art

Crystallization is one of the most widely used separation processes in the
chemical and pharmaceutical industries, with some 80% of products going
10 through a crystallisation step at some point in their manufacture.

Crystallisation determines product quality, such as desired morphology
and size distribution for subsequent filtering, washing, reaction with other
chemicals, transporting, tableting, packaging and storage.

15 However, despite its importance and significant research efforts,
crystallisation remains one of the least well understood and most difficult
manufacturing processes to control. For example, at present there is no
way to monitor and control primary nucleation.

20 Primary nucleation can be homogeneous or heterogeneous.

Homogeneous primary nucleation is the initial formation of crystal nuclei
where there are no other crystals present at all. Heterogeneous primary
nucleation is where impurities that are present induce the formation of
crystals either spontaneously or due to a change in environmental
25 conditions (such as a drop in temperature, for example). This is distinct
from secondary nucleation where the formation of crystal nuclei is
attributable to the presence of existing microscopic crystals, which have
been deliberately added, i.e., seeding.

Generally, primary nucleation cannot be monitored or controlled because the size of the nuclei generated is too small and the concentration of the nuclei generated is too low to detect using currently available techniques. Therefore, at present there is no way to separate and independently study
5 the nucleation of crystal nuclei and the growth of crystals. The ability to carry out such studies would be of significant importance as nucleation largely dictates the final characteristics of a crystal.

EP1 965900 describes a crystallisation apparatus having independent
10 temperature control in different process zones. However, there is no clear way to separate and/or control nucleation and growth of crystals. Also, it is known to induce nucleation using ultrasound, but such devices are generally very expensive, energy intensive and in some cases unreliable. Using seed crystals ("seeding") is the most common method of inducing
15 nucleation in industrial crystallisation operations, primarily because it can provide the final crystals with the same characteristics as the seed crystals. However, seeding requires a large number of experimental tests to be carried out in order to understand the effect of size, amount and quality of the seeds on the properties of the crystallised product so
20 obtained.

Therefore, it is an object of the invention to overcome at least some of the disadvantages of the prior art.

25 Further aims and objects of the invention will be apparent from the description herein and the advantages provided by the invention.

Disclosure of Invention

According to a first aspect of the invention there is provided a device for inducing crystal nucleation in a crystalliser and being configured for fluid attachment thereto, the device comprising a vessel for fluid and a surface abrader, wherein the surface abrader is configured to abrade a surface
5 within the vessel to induce crystal nucleation.

The device is a nucleation generator. The device (nucleation generator) is significantly cheaper and more reliable than known ultrasound devices.

10 To date, it has not been possible to separate crystal nucleation and crystal growth. The generation and control of primary nucleation enables the avoidance of using seeding as a source of secondary nucleation.

Preferably the surface abrader is configured to abrade the inside surface
15 of the vessel.

The friction of the abrader against the surface within the vessel creates nano-sized particulates which induce crystal nucleation. Crystal growth can then take place in the crystalliser.
20

The device may further comprise a reciprocating actuator, wherein the reciprocating actuator comprises the surface abrader.

The reciprocating actuator may comprise a reciprocating shaft joined to a
25 baffle set.

The reciprocating actuator may be a linear actuator or, alternatively, can be a non-linear actuator.

The reciprocating actuator may be a double ended piston.

The vessel may be a tubular vessel, optionally a substantially cylindrical vessel.

5

The vessel may comprise an outlet configured for fluid connection to the crystalliser, and optionally an inlet for receiving one or more substances.

10 Preferably the surface abrader comprises one or more annular baffles having a rim defined by the circumference thereof, wherein the annular baffle is sized and arranged such that the rim contacts the inner surface of the vessel.

15 The surface abrader may comprise a plurality of annular baffles,

The annular baffles may be arranged in a substantially equidistant manner, optionally substantially in parallel such that they extend radially inwards from the inside surface of the vessel.

20 The distance between the annular baffles may be between about $1d$ and $2d$ where d is diameter of the annular baffle.

Typically the annular baffles are joined together on rails.

25 The annular baffles can be substantially flat plates comprising an aperture located approximately centrally in said plate.

Typically the baffles have a free area ratio of from about 0.1 to about 0.9, more typically from about 0.1 to about 0.5, most typically from about 0.18

to about 0.25, preferably from about 0.21 to about 0.23, most preferably 0.21 .

According to a second aspect of the invention there is provided a
5 crystallisation apparatus comprising at least a first section and a second
section in fluid connection, the first section comprising a device for
inducing formation of crystal nuclei, and the second section comprising a
crystalliser configured to facilitate crystal growth, wherein the device
comprises a vessel for fluid and a surface abrader configured to abrade a
10 surface within the vessel to induce crystal nucleation.

The device is a nucleation generator.

To date, it has not been possible to separate crystal nucleation and crystal
15 growth. The generation and control of primary nucleation enables the
avoidance of using seeding as a source of secondary nucleation.

The friction of the abrader against the surface within the vessel creates
nano-sized particulates which induce crystal nucleation. Crystal growth
20 can then take place in the crystallisation apparatus.

Preferably the crystalliser comprises a vessel for fluid, optionally a tubular
vessel, optionally a substantially cylindrical vessel.

25 The crystalliser may comprise an inlet configured for fluid connection to
the device, and optionally an outlet configured for fluid connection to the
device.

The crystalliser may comprise an inlet for receiving one or more substances and/or an outlet for discharging one or more substances.

5 It will be appreciated that the crystalliser, the device, the crystallisation apparatus and the vessels that make up the same are able to receive, hold and discharge various substances such as fluid, liquids, slurries, suspensions and other mixes of phases such as, for example, a solid crystalline product suspended or contained within a supernatant fluid or mother liquor.

10

Preferably the crystalliser comprises one or more annular baffles, typically the annular baffles in the crystalliser are static.

The crystalliser may comprise a plurality of annular baffles.

15

The annular baffles may be arranged in a substantially equidistant manner, optionally substantially in parallel such that they extend radially inwards from the inside surface of the vessel.

20 Typically the distance between the annular baffles is between about $1d$ and $2d$ where d is diameter of the annular baffle.

The annular baffles may be joined together on rails.

25 Typically the annular baffles are substantially flat plates comprising an aperture located approximately centrally in said plate.

Typically the baffles have a free area ratio of from about 0.1 to about 0.9, more typically from about 0.1 to about 0.5, most typically from about 0.18

to about 0.25, preferably from about 0.21 to about 0.23, most preferably 0.21 .

5 The crystalliser may comprise a series of vessels arranged and operatively connected in a flow system to form at least one continuous fluid flow path, and wherein the device for inducing formation of crystal nuclei is fluidly connected to said fluid flow path.

10 The apparatus can be used in a continuous, semi-continuous or fed batch process. The device can be placed at the start of or further along the fluid flow path.

15 The vessels may be configured to follow a succession of return paths in one or more parallel planes. Further return paths can be arranged perpendicular to the parallel planes.

20 The return paths may define discrete process zones, each process zone comprising a temperature regulator for independently controlling the temperature thereof.

Optionally at least two successive vessels are fluidly connected to each other by a device for inducing formation of crystal nuclei, so forming a return path.

25 The apparatus may further comprise a flow controller configured to control flow of one or more substances into the apparatus.

The apparatus may further comprise an oscillator configured to impart motion to the contents of the apparatus.

The device may further comprise a reciprocating actuator. The oscillator may be a reciprocating actuator.

- 5 The reciprocating actuator may be a linear actuator or, alternatively, can be a non-linear actuator.

The reciprocating actuator may be a double ended piston.

- 10 Primary nucleation may take place in the device for inducing formation of crystal nuclei.

Preferably primary nucleation occurs substantially exclusively in the device for inducing formation of crystal nuclei. Typically crystal growth occurs

- 15 substantially exclusively in the crystalliser.

The device used in the second aspect may be as described in the first aspect.

- 20 According to a third aspect of the invention there is provided a crystallisation process comprising the steps of:

- i. providing a crystallisation apparatus having a first section and a second section in fluid connection, the first section comprising a device for inducing formation of crystal nuclei, and the second
25 section comprising a crystalliser configured to facilitate crystal growth;
- ii. inducing nucleation in the first section; and
- iii. growing crystals in the second section.

The device is a nucleation generator.

The nucleation in the first section may be primary nucleation.

- 5 The device may comprise a vessel for fluid and a surface abrader configured to abrade a surface within the vessel, wherein inducing nucleation comprises abrading the surface within the vessel with the abrader.
- 10 Preferably the abrasion is effected by reciprocation of the surface abrader against the inside surface of the vessel.

- Primary nucleation may occur substantially exclusively in the device for inducing formation of crystal nuclei, and the so formed crystal nuclei are
- 15 transported to the crystalliser.

The crystal growth may occur substantially exclusively in the crystalliser.

- The process of the third aspect may be carried out using the apparatus of
- 20 the second aspect.

Embodiments of the invention will now be described, by way of example only, with reference to the drawings, in which:

25 **Brief Description of the Drawings**

Figure 1 is a device for inducing nucleation in accordance with one embodiment of the invention;

Figure 2 is a crystallisation apparatus in accordance with one embodiment of the invention; and

Figure 3 is a crystallisation apparatus in accordance with an alternative embodiment of the invention.

Detailed Description

5 Referring to Figure 1, there is shown a nucleation device 10 having a jacket 12 and a glass column (vessel) 14 of internal diameter 50 mm and a height of approximately 500 mm, giving a working volume of 500 mL. The vessel 14 is held in position by a stainless steel flange 16. There is shown a baffle string 18 comprised of four PTFE annular baffles 20 with an outer diameter of 48 mm, an orifice diameter of 24 mm and a thickness of 3 mm. The baffles 20 are spaced equidistantly at 65 mm by stainless steel spacers 22 and are arranged in parallel and such that they extend radially inwards from the sides of the vessel 14. The baffles 20 are oscillated in the vessel 14 by means of a linear motor 24 (Copley Controls Corp.), which was held by an aluminium/plastic frame (not shown). The linear motor 24 has an actuator 26 connected to the baffle set 18, which together act as a linear oscillator or a reciprocating actuator. Frequencies of 0-10 Hz and amplitudes of 0-50 mm are possible in this particular example. Also shown is a temperature controller 30 for controlling the temperature inside the nucleation device 10.

Turning to Figures 2 and 3, there is shown a crystalliser 50 having a nucleation device 10 in fluid connection therewith. The crystalliser 50 and the nucleation device 10 together form a crystallisation apparatus 80. Also shown is an inlet 52 and an outlet 54 which enables the introduction and discharge of substances from the crystalliser 50 or crystallisation apparatus 80. The flow of substances via the inlet can be controlled by a flow controller (not shown).

The crystalliser 50 is formed from a tubular vessel 56 and has a number of annular baffles 58 arranged in parallel on rails (not shown) and spaced equidistantly. Note that the annular baffles are not arranged in parallel where the crystalliser has a U-shaped section. The annular baffles 58 are static. Also shown is an actuator 60 connected to a linear motor 62 and which imparts oscillatory motion to the contents of the vessel 56. This acts as a linear oscillator or a reciprocating actuator.

In Figure 2, the oscillation of the nucleation device 10 is imparted using an arrangement similar to that shown in Figure 1.

In Figure 3, the oscillation of the nucleation device 10 is imparted using a magnetic oscillator (not shown) as is known in the art.

The crystalliser is fluidly attached to the nucleation device by way of an inlet and outlet that connect to the corresponding inlet and outlet of the nucleation device.

In one embodiment the crystalliser has a series of vessels arranged and operatively connected in a flow system to form a continuous flow path. The vessels can be arranged to follow a succession of return paths in one or more parallel or perpendicular planes.

In use, a solvated product to be crystallised is provided to the crystallisation apparatus via an inlet and the contents of the crystallisation apparatus are oscillated. The solvated product enters the nucleation device where primary nucleation takes place by way of the oscillating baffle set abrading the inside surface of the vessel. The solvated product with crystal nuclei is then fluidly transferred from the nucleation device to

the crystalliser where the solvated product crystallises from solution in a controlled manner. The whole process is carried out in a continuous manner allowing fast processing of substances.

- 5 Throughout the whole process intimate mixing is maintained by way of the oscillation and the static baffles. This is important in ensuring consistency in the end product.

10 Nucleation occurs substantially exclusively in the nucleation device and crystal growth occurs substantially exclusively in the crystalliser.

15 A temperature control mechanism (regulator) as is known in the art can also be added to give increased control of the crystallisation process. In particular, individual areas of the crystalliser can be process zones, the temperature of which can be independently controlled.

20 The nucleation device can induce nucleation and can be configured for fluid attachment to a crystalliser (see Figures 2 and 3). The baffle set/string and, in particular the rim of the annular baffles, acts as a surface abrader and is sized shaped and configured to abrade a surface within the vessel, more particularly the inside surface of the vessel walls at controlled frequencies and scraping distances. Although described with reference to an oscillating baffle set, it will be appreciated that the abrasion can be carried out using other devices (i.e., abraders or surface abraders) that
25 generate an abrasive or scraping effect such as brushes, rods, sticks, wheels or the like which are of a material, size, shape and are positioned to abrade a surface within the vessel.

The reciprocating actuators described above may be linear actuators such as a solenoid-type arrangement or, where appropriate, can be non-linear actuators such as a rotating motor with a linkage arrangement or, where appropriate, can be a double ended piston arrangement. Non-linear
5 actuators can convert rotational movement into linear movement, whereas linear actuators generally involve only linear movement.

The various vessels described can be tubular or cylindrical and may have inlets and outlets to enable transfer of substances into, out of, or between
10 the vessels (for example, between the nucleation device and the crystal liser).

The baffles described above are annular but can be of an alternative shape that enables efficient mixing to be achieved. Whilst specific
15 spacings are given above, the baffle spacing is typically from 1d to 2d where d is the diameter of the baffle. The baffles may be joined on rails and can be substantially flat plates comprising an aperture located approximately centrally on the plate.

20 The free area ratio of the baffle is defined by the area of the orifice (aperture) divided by the total baffle area (or the ratio of the baffle area over the tube across sectional area, i.e. $a = (D_b/D_t)^2$).

In the example given above the baffle free area ratio is 0.21 . The baffle
25 free area ratio can be from around 0.1 to about 0.9. In one embodiment the baffle free area ratio is from about 0.1 to about 0.5. In a preferred embodiment the working baffle free area ratio range is typically from about 0.18 to about 0.25. In a particularly advantageous embodiment mixing is achieved using baffle free area ratio of about 0.21 to about 0.23.

The crystallisation apparatus described above has a first section, being the nucleation device, in fluid connection with a second section, being a crystalliser.

5

Example of Nucleation

An experiment was designed to determine the nucleation mechanism occurring in the nucleation device. This experiment used sodium chlorate, as it exhibits enantiomorphism in the solid state, the morphology of which can provide information on the mechanism of nucleation. Sodium chlorate is a non-chiral substance that on crystallization produces crystalline solids possessing either a left or right handed enantiomorphism. As such, the crystalline solid will display optical activity, a property that can be studied to determine the handedness of the crystals based on the direction of rotation of plane polarized light.

10
15

Two relevant investigations into nucleation mechanism were reported in 1972 by Denk and Botsaris (Denk, E.G. and Botsaris G.D., Fundamental studies in secondary nucleation from solution. *J. Cryst. Growth*, 1972.

20 **13/14:** p. 493-499; Denk, E.G. and Botsaris G.D., Mechanism of contact nucleation. *J. Cryst. Growth*, 1972. **15:** p. 57-60), where at super-cooling of 3 °C and 350 RPM stirring, a crop of product crystals had 100 % right handedness when seeded with a single right handed crystal. The same outcome was reported for seeding with a left handed crystal. This indicates that secondary nucleation took place due to either dendrite coarsening or collision breeding within the crystallizer, i.e. the entire product crystals originated directly from the seed crystal. However, the study found that without seeding and also at higher super-cooling (greater than 7 °C), primary nucleation was observed. This was shown from the

25

50:50 mixture of left and right handed product crystals observed. This indicates that if spontaneous nucleation was occurring, a mixture of both left and right handed crystals would be the evidence.

5 Therefore, by studying the product crystal handedness it is possible to probe the nucleation mechanism when the hydrodynamic environment is changed. Provided that the process conditions such as super-saturation, temperature and mixing intensity are constants, any changes in product crystals can be attributed to the mixing mechanism.

10

If seeding with a right handed crystal yields exclusively right handed crystals, then a nucleation mechanism (secondary nucleation from seeding) such as that proposed by Denk and Botsaris can be assumed to have taken place in the nucleation device. If, however, mixtures of both
15 left and right handed crystals are observed, a combination of primary and secondary nucleation can be assumed to have occurred.

The nucleation device was arranged as illustrated in Figure 1, and was serviced by a water bath and a temperature monitoring tool.

20

The power dissipation of the nucleation device was estimated using the quasi steady flow model proposed by Baird and Stonestreet (Baird, M.H.I. and Stonestreet P., Energy dissipation in oscillatory flow within a baffled tube. *Chemical engineering research and design*, 1995. 73(5): p. 503-51 1)
25 using the following parameters: number of baffles per unit length (15.38 m^{-1}), discharge coefficient of the baffles (0.7), centre to peak amplitude of oscillation (m, noted below), oscillation frequency (Hz, noted below), and the baffle free area ratio (0.23). The free area ratio is defined by the area

of the orifice divided by the total baffle area (or the ratio of the baffle area over the tube across sectional area, i.e. $a = (D_b/D_t)^2$).

5 Heating and chilling were provided using a Grant GP200R2 heater/chiller and a water jacket. The temperature was monitored by using stainless steel T-Type thermocouples and a four channel temperature display, which was interfaced to a PC to record the temperature profile.

The sodium chlorate used was sourced from Fisher Scientific UK.

10

Seed crystals were prepared by naturally cooling a quiescent sodium chlorate solution in a 250 ml_ conical flask using the following procedure. Sodium chlorate and water were mixed in a sealed flask, which was immersed in a water bath at 30 °C. Once the material had dissolved, the flask was removed and allowed to cool to room temperature. After leaving the solution overnight, the crystals were extracted by filtration using a Buchner funnel and filter paper (Whatman Grade 1). The crystals were immediately washed with 20 ml_ of cold water to remove any traces of mother liquor and then dried between filter papers to provide seed crystals.

15

20

The handedness of the seed crystals was determined prior to use by polarimetry.

25 The following trials were carried out using constant process conditions, such as super-saturation, concentration, and cooling, etc. The constants used are outlined in table 1.

T_{SAT} (°C)	C (g NaClO ₃ /100 mL sat. sol.)	Volume (mL)	Dissolution temp. (°C)	Dissolution time (min)	ΔT (°C)	Seed time (min)	No. Of repeats
31	73.79	500	40	60	1	3	3

Table 1

The mixing conditions studied are shown in Table 2.

5

f (Hz)	x_0 (mm)	P/V (W m ⁻³)
0.4	32	11.13

Table 2

Three separate types of experiment were carried out: (i) seeding and agitation; (ii) seeding and no agitation; and (iii) no seeding and agitation.

The general experimental procedure involved weighing out the required amounts of reagent (368.94g) within the nucleation device and holding the at 40 °C for one hour under the agitation conditions given in Table 2 to ensure that all solid particles had dissolved. After dissolution, the solution was filtered using a Whatman glass fibre filter to remove any foreign particles. The solution was then cooled to the super-saturation point under controlled conditions. Where applicable a single seed crystal of known handedness was washed with cold distilled water before being suspended by means of a wire in the crystallizing solution for three minutes. The wire is prewashed and dried. The seed crystal was then removed from the solution and the agitation stopped to allow the product crystals to grow overnight to form larger crystals.

In the experiments where no agitation was applied, the agitation used for initial dissolution was stopped prior to seeding. For the non-seeded tests, the agitation was stopped and the quiescent solutions held overnight.

- 5 Product crystals were collected and quickly washed with 20 mL of cold HPLC grade water and dried on filter paper. Analysis of the crystals was performed using a polarimeter. The left and right handed crystals were then separated and weighed. Each experiment was repeated a further two times in order to determine the margin of error within the data. The apparatus was thoroughly cleaned between trials.

A number of benchmark experiments were also performed where no mixing was applied to nucleation device. This was to illustrate that it is the mixing mechanism that has an effect on the nucleation. The first set of benchmark results are shown in Tables 3 and 4:

Trial	Mass Right (g)	Mass Left (g)	Total mass (g)	Similarity to seed (%)
1	24.8	0	24.8	100
2	21.2	0	21.2	100
Mean	23	0	23	100
S.D.	2.55	0	2.55	0

Table 3 - Results for right handed seeds and no mixing

Trial	Mass Right (g)	Mass Left (g)	Total mass (g)	Similarity to seed (%)
1	0	24.2	24.2	100
2	0	22.8	22.8	100
Mean	0	23.5	23.5	100
S.D.	0	0.99	0.99	0

20

Table 4 - Results for left handed seeds and no mixing

When no mixing was applied before, during and after the seeding, it can be seen that all product crystals bore the same handedness as the seed crystal. This indicates that secondary nucleation is the only mechanism in these tests and implies that primary nucleation did not occur. If primary nucleation had occurred, a mixture of left and right handed crystals would have been observed as primary nucleation yields left and right handed product crystals as shown by Denk and Botsaris.

In order to verify that no spontaneous nucleation would occur as a result of surface phenomena, a second set of benchmark experiments were conducted in the same manner as the first set, except no seeding was used. The nucleation device was left overnight and it was found that no crystals were present, thus indicating that the entrainment of foreign particles to initiate heterogeneous primary nucleation was not possible. This also suggests that seeds are necessary to initiate nucleation.

Following on from the benchmark experiments, further experiments were carried out wherein mixing was applied to the two systems. Tables 5 and 6 display the outcomes.

Trial	Mass Right (g)	Mass Left (g)	Total mass (g)	Similarity to seed (%)
1	22.5	3	25.5	88
2	28.2	1.4	29.6	95
3	30.4	1.5	31.9	95
Mean	27.00	1.97	29.00	92.67
S.D.	4.08	0.90	3.24	4.04

Table 5 - Results for right handed seeds and mixing

Trial	Mass Right (g)	Mass Left (g)	Total mass (g)	Similarity to seed (%)
1	1.1	23	24.1	95
2	1.4	20.5	21.9	94
3	1.2	21.6	22.8	95
Mean	1.23	21.70	22.93	94.67
S.D.	0.15	1.25	1.11	0.58

Table 6 - Results for left handed seeds and mixing

From the results of three trials for each enantiomorph, it is clear that under
 5 the conditions studied in this work the nucleation device consistently gave
 product crystals with ≤ 95 % similarity to the seed handedness when
 mixed. Whilst secondary nucleation is still a dominant feature, some sort
 of primary nucleation must be occurring in order to have the few product
 crystals with opposite handedness to the seed. This implies a nucleation
 10 device creating primary nucleation.

Similar experiments to those outlined above were carried out in a
 traditional stirred tank crystalliser. The results showed that 100 % of the
 product crystals from the trials bear the same handedness as the seed,
 15 irrespective of whether or not there is agitation. Therefore, it would appear
 that the nucleation mechanism is exclusively secondary for traditional
 stirred tank crystallisers.

Thus, it can be concluded that the scraping/abrasive effect of the baffles of
 20 the nucleation device on the inside wall of the column (vessel) when the
 baffle string is moving up and down causes primary nucleation. This
 interaction cause sufficient friction to induce primary nucleation which
 results in a mixture of left and right handed crystals in the product.

To verify this, a further experiment was designed wherein there is an increased gap between the baffle set and the tube (vessel) ensuring that the scraping/abrasive effect would be eliminated or at least reduced. If the scraping/abrasive effect is causing the primary nucleation, the experiments carried out with this redesigned apparatus should provide 100 % of product crystals having the same handedness as the seed crystal.

The results are now shown in Tables 7 and 8.

Trial	Mass Right (g)	Mass Left (g)	Total mass (g)	Similarity to seed (%)
1	2.49	0.01	2.50	99.6
2	4.39	0	4.39	100
3	4.73	0.07	4.80	98.5
Mean	3.87	0.03	3.90	99.37
S.D.	1.21	0.04	1.23	0.78

10

Table 7 - Results for right handed seeds and device with increased gap between edge of baffle and inside of vessel wall

Trial	Mass Right (g)	Mass Left (g)	Total mass (g)	Similarity to seed (%)
1	0.23	3.84	4.07	94
2	0	3.95	3.95	100
3	0	4.15	4.15	100
Mean	0.08	3.98	4.06	98.00
S.D.	0.13	0.16	0.10	3.46

15 Table 8 - Results for left handed seeds and device with increased gap between edge of baffle and inside of vessel wall

From the above data, it can be seen that when gap between the baffle set and the tube (vessel) is increased, the results show a shift in similarity to

seed towards the 100 % level. This verifies that it is the scraping effect of the baffle set on the inside of the vessel that is the source of the primary nucleation.

- 5 The results in tables 3 and 4 show that when seeded with a single crystal of sodium chlorate of known handedness 100 % of the same handedness crystal product is obtained without the presence of mixing. However, when agitation is introduced under identical power density and conditions, only around 94~95 % of product crystals of the same handedness as the
- 10 seed are obtained, along with around 5~6 % of the opposite handedness crystals (see tables 5 and 6). This means that some kind primary nucleation had taken place within the nucleation device. When the gap between the baffle set and the inside wall of the vessel is increased, closer to 100 % of product crystals of the same handedness as the seed are
- 15 obtained (see tables 7 and 8). This confirms that the scraping/abrasion of the baffles on the inside wall of the vessel is responsible for the primary nucleation.

Traditionally nucleation is induced by adding seeds at specific time of a

20 crystallisation process, the properties of seeds, e.g. size, amount, quality, have significant effects on nucleation and subsequent growth. The example described above shows that the scraping effect of baffle-movement against the wall of the vessel generates primary nucleation events. The invention described above allows this effect to be applied to

25 enable crystallisation to be carried out in a controlled and predictable manner, without the use of seeding. Furthermore, the invention enables crystal nucleation and crystal growth to be separated, providing better control of the process and potentially enabling the processes of nucleation and growth to be studied independently.

Surprisingly, the invention of the present application enables nucleation to take place at a higher temperature and with a narrower metastable zone than in traditional stirred tank crystallisers. It also provides more
5 consistent crystal morphology and rapid crystal growth without the entrainment of impurities, which is normally associated with rapid crystal growth in traditional crystallisers.

The ability to separate crystal nucleation and growth has a profound
10 impact on the science of crystallisation and on the technological applications to which crystallisation is applied. For example, it enables the scientific study and advancement of nucleation theories such as nucleation kinetics. Ultimately, the invention enables the production of predesigned crystals.

15

In one aspect the invention may be readily applied to existing reactors especially existing baffled reactors, such as oscillatory baffled reactors used for crystallisation.

20 Various modifications and variations to the described embodiments of the invention will be apparent to those skilled in the art without departing from the scope and spirit of the invention. Although the invention has been described in connection with specific embodiments, it should be understood that the invention as claimed should not be unduly limited to
25 such specific embodiments. Indeed, various modifications of the described modes of carrying out the invention which are obvious to those skilled in the art are intended to be covered by the present invention.

CLAIMS

1. A device for inducing crystal nucleation in a crystalliser and being configured for fluid attachment thereto, the device comprising a vessel for fluid and a surface abrader, wherein the surface abrader is configured to abrade a surface within the vessel to induce crystal nucleation.
5
2. A device as claimed in claim 1, wherein the surface abrader is configured to abrade the inside surface of the vessel.
10
3. A device as claimed in claim 1 or claim 2, wherein the device further comprises a reciprocating actuator, wherein the reciprocating actuator comprises the surface abrader.
15
4. A device as claimed in any preceding claim, wherein the vessel is a tubular vessel, optionally a substantially cylindrical vessel.
5. A device as claimed in any preceding claim, wherein the vessel comprises an outlet configured for fluid connection to the crystalliser, and optionally an inlet for receiving one or more substances.
20
6. A device as claimed in any preceding claim, wherein the surface abrader comprises one or more annular baffles having a rim defined by the circumference thereof, wherein the annular baffle is sized and arranged such that the rim contacts the inner surface of the vessel.
25

7. A device as claimed in claim 6, wherein the surface abrader comprises a plurality of annular baffles.
- 5 8. A device as claimed in claim 6 or claim 7, wherein the annular baffles are arranged in a substantially equidistant manner.
9. A device as claimed in any one of claims 6 to 8, wherein the annular baffles are arranged substantially in parallel, such that they extend radially inwards from the inside surface of the vessel.
- 10 10. A device as claimed in any one of claims 6 to 9, wherein the distance between the annular baffles between about $1d$ and $2d$ where d is diameter of the annular baffle.
- 15 11. A device as claimed in any one of claims 6 to 10, wherein the annular baffles are joined together on rails.
12. A device as claimed in any one of claims 6 to 11, wherein the annular baffles are substantially flat plates comprising an aperture located approximately centrally in said plate.
- 20 13. A device as claimed in any one of claims 6 to 12, wherein the baffles have a free area ratio of from about 0.1 to about 0.9, typically from about 0.1 to about 0.5, more typically from about 0.18 to about 0.25, most typically from about 0.21 to about 0.23, preferably 0.21 .
- 25 14. A crystallisation apparatus comprising at least a first section and a second section in fluid connection, the first section comprising a device for inducing formation of crystal nuclei, and the second
- 30

section comprising a crystalliser configured to facilitate crystal growth, wherein the device comprises a vessel for fluid and a surface abrader configured to abrade a surface within the vessel to induce crystal nucleation.

5

15. An apparatus as claimed in claim 14, wherein the crystalliser comprises a vessel for fluid, optionally a tubular vessel, optionally a substantially cylindrical vessel.
- 10 16. An apparatus as claimed in claim 14 or claim 15, wherein the crystalliser comprises an inlet configured for fluid connection to the device, and optionally an outlet configured for fluid connection to the device.
- 15 17. An apparatus as claimed in any one of claims 14 to 16, wherein the crystalliser comprises an inlet for receiving one or more substances and/or an outlet for discharging one or more substances.
18. An apparatus as claimed in any one of claims 14 to 17, wherein the
20 crystalliser comprises one or more annular baffles.
19. An apparatus as claimed in claim 18, wherein the annular baffles in the crystalliser are static.
- 25 20. An apparatus as claimed in claim 18 or claim 19, wherein the crystalliser comprises a plurality of annular baffles.
21. An apparatus as claimed in any one of claims 18 to 20, wherein the annular baffles are arranged in a substantially equidistant manner.

30

22. An apparatus as claimed in any one of claims 18 to 21, wherein the annular baffles are arranged substantially in parallel, such that they extend radially inwards from the inside surface of the vessel.
- 5 23. An apparatus as claimed in any one of claims 18 to 22, wherein the distance between the annular baffles between about $1d$ and $2d$ where d is diameter of the annular baffle.
- 10 24. An apparatus as claimed in any one of claims 18 to 23, wherein the annular baffles are joined together on rails.
25. An apparatus as claimed in any one of claims 18 to 24, wherein the annular baffles are substantially flat plates comprising an aperture located approximately centrally in said plate.
- 15 26. An apparatus as claimed in any one of claims 18 to 25, wherein the baffles have a free area ratio of from about 0.1 to about 0.9, typically from about 0.1 to about 0.5, more typically from about 0.18 to about 0.25, most typically from about 0.21 to about 0.23, preferably 0.21 .
- 20 27. An apparatus as claimed in any one of claims 14 to 26, wherein the crystalliser comprises a series of vessels arranged and operatively connected in a flow system to form at least one continuous fluid flow path, and wherein the device for inducing formation of crystal nuclei is fluidly connected to said fluid flow path.
- 25 28. An apparatus as claimed in any one of claims 14 to 27, wherein the vessels are configured to follow a succession of return paths in one or more parallel planes.
- 30

29. An apparatus as claimed claim 28, wherein at least two successive vessels are fluidly connected to each other by a device for inducing formation of crystal nuclei, so forming a return path.
- 5
30. An apparatus as claimed in any one of claims 14 to 29, wherein the apparatus further comprises a flow controller configured to control flow of one or more substances into the apparatus.
- 10
31. An apparatus as claimed in any one of claims 14 to 30, wherein the apparatus further comprises an oscillator configured to impart motion to the contents of the apparatus.
- 15
32. An apparatus as claimed in any one of claims 14 to 31, wherein the device further comprises a reciprocating actuator.
- 20
33. An apparatus as claimed in any one of claims 14 to 32, wherein primary nucleation takes place in the device for inducing formation of crystal nuclei.
- 25
34. An apparatus as claimed in any one of claims 14 to 33, wherein primary nucleation occurs substantially exclusively in the device for inducing formation of crystal nuclei.
- 30
35. An apparatus as claimed in any one of claims 14 to 34, wherein crystal growth occurs substantially exclusively in the crystalliser.
36. An apparatus as claimed in any one of claims 14 to 35, wherein the device is as described in any one of claims 1 to 13.

37. A crystallisation process comprising the steps of:
- i. providing a crystallisation apparatus having a first section and a second section in fluid connection, the first section comprising a device for inducing formation of crystal nuclei, and the second section comprising a crystalliser configured to facilitate crystal growth;
 - ii. inducing nucleation in the first section; and
 - iii. growing crystals in the second section.
38. A process as claimed in claim 37, wherein the device comprises a vessel for fluid and a surface abrader configured to abrade a surface within the vessel, and wherein inducing nucleation comprises abrading the surface within the vessel with the abrader.
39. A process as claimed in claim 37 or 38, wherein the abrasion is effected by reciprocation of the surface abrader against the inside surface of the vessel.
40. A process as claimed in any one of claims 37 to 39, wherein primary nucleation occurs substantially exclusively in the device for inducing formation of crystal nuclei, and the so formed crystal nuclei are transported to the crystalliser.
41. A process as claimed in claim 40, wherein crystal growth occurs substantially exclusively in the crystalliser.
42. A process as described in any one of claims 37 to 41 using the apparatus as described in claims 14 to 36.

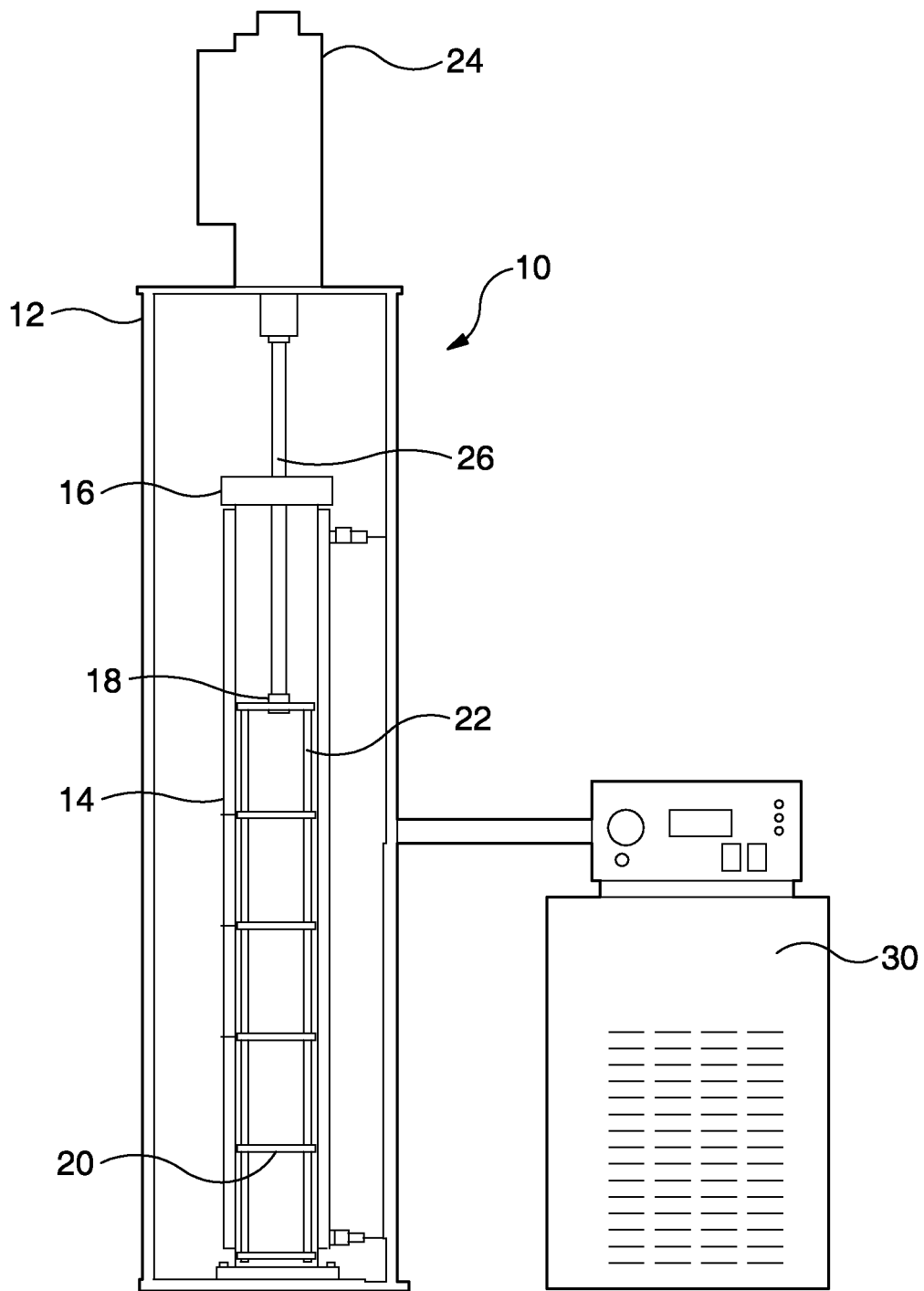

Figure 1

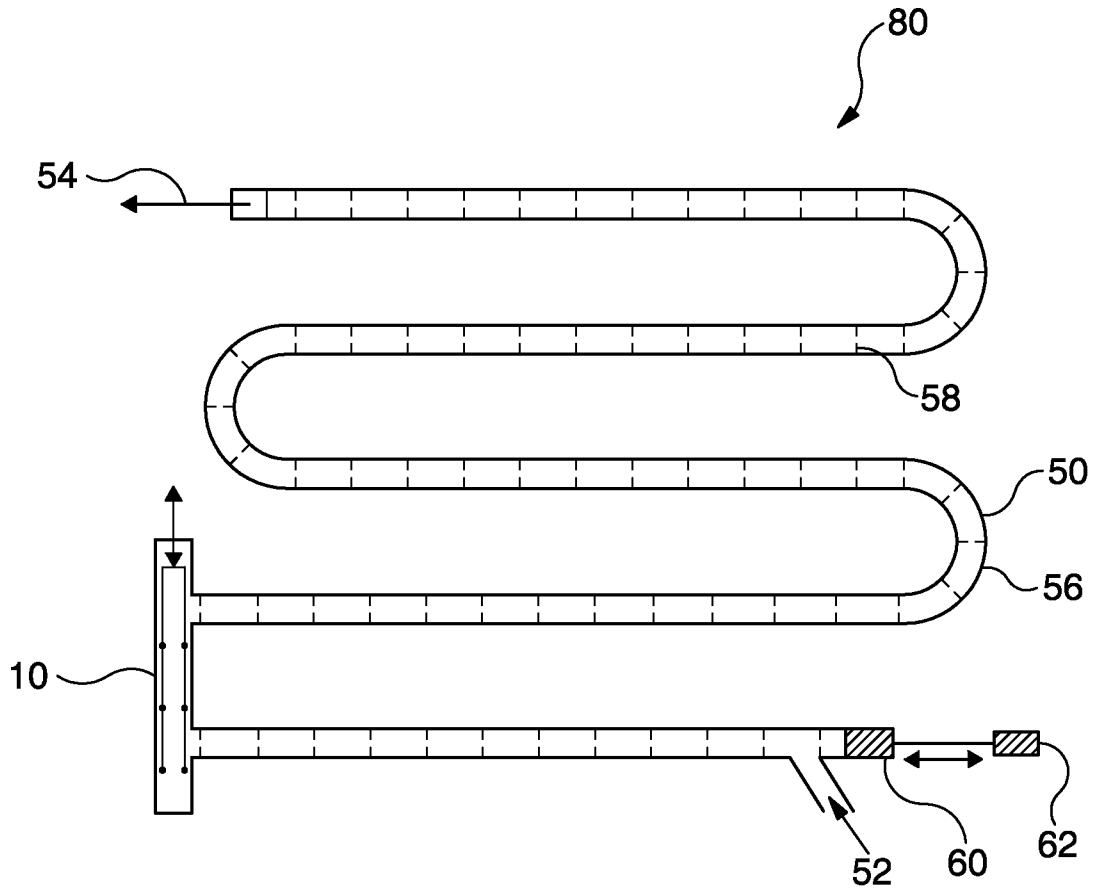

Figure 2

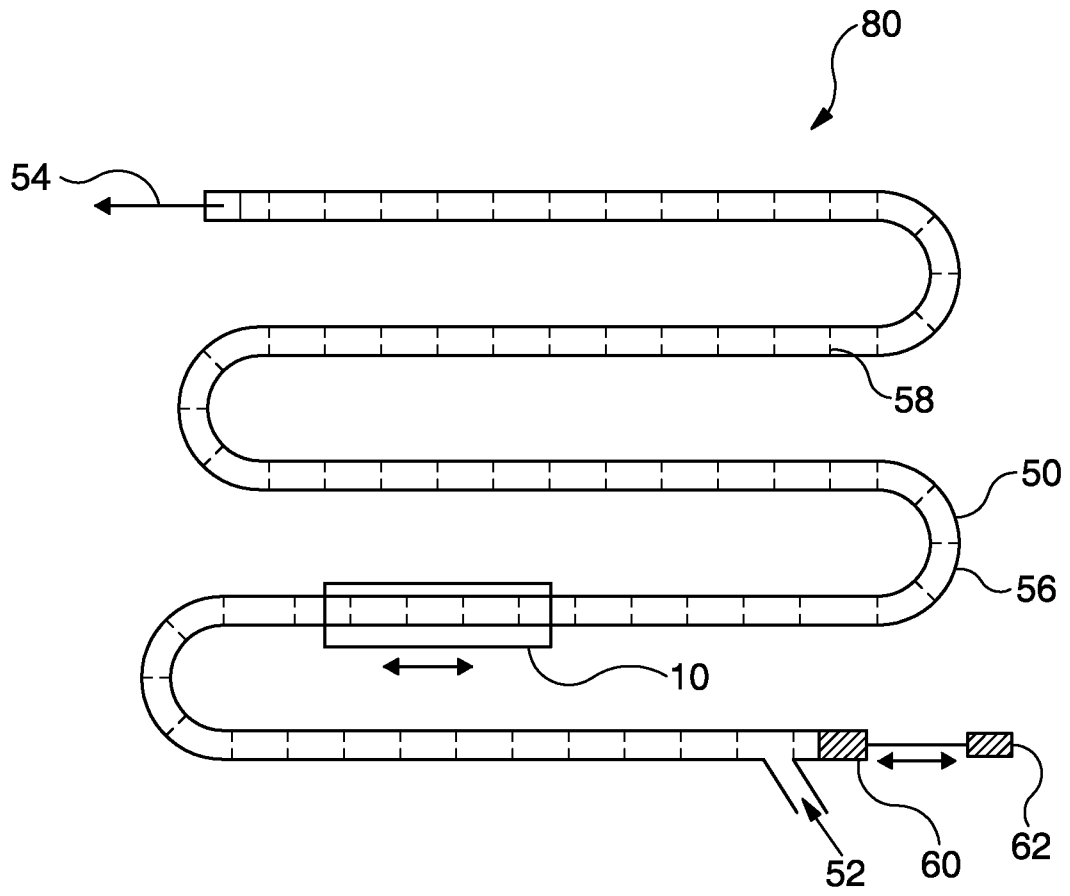

Figure 3

INTERNATIONAL SEARCH REPORT

International application No PCT/GB2012/053111
--

A. CLASSIFICATION OF SUBJECT MATTER
INV. B01J19/00 B01J19/24 B01D9/00 F28F1/40 B01J19/18
 ADD.

According to International Patent Classification (IPC) or to both national classification and IPC

B. FIELDS SEARCHED

Minimum documentation searched (classification system followed by classification symbols)
B01J B01D F28F

Documentation searched other than minimum documentation to the extent that such documents are included in the fields searched

Electronic data base consulted during the international search (name of data base and, where practicable, search terms used)
EPO-Internal , WPI Data

C. DOCUMENTS CONSIDERED TO BE RELEVANT

Category*	Citation of document, with indication, where appropriate, of the relevant passages	Relevant to claim No.
X	US 4 004 886 A (THIJSSSEN HENRICUS A C ET AL) 25 January 1977 (1977-01-25) the whole document -----	1, 2, 4, 5 , 14-17 , 33-38, 40-42
X	US 2 672 487 A (TEGGE BRUCE R ET AL) 16 March 1954 (1954-03-16) the whole document -----	1, 2, 4, 5 , 14-17 , 33-38, 40-42
X	US 5 966 966 A (BOTSARIS GREGORY D [US] ET AL) 19 October 1999 (1999-10-19) abstract; figure 1 ----- -/--	37, 40, 41

Further documents are listed in the continuation of Box C. See patent family annex.

* Special categories of cited documents :

<p>"A" document defining the general state of the art which is not considered to be of particular relevance</p> <p>"E" earlier application or patent but published on or after the international filing date</p> <p>"L" document which may throw doubts on priority claim(s) or which is cited to establish the publication date of another citation or other special reason (as specified)</p> <p>"O" document referring to an oral disclosure, use, exhibition or other means</p> <p>"P" document published prior to the international filing date but later than the priority date claimed</p>	<p>"T" later document published after the international filing date or priority date and not in conflict with the application but cited to understand the principle or theory underlying the invention</p> <p>"X" document of particular relevance; the claimed invention cannot be considered novel or cannot be considered to involve an inventive step when the document is taken alone</p> <p>"Y" document of particular relevance; the claimed invention cannot be considered to involve an inventive step when the document is combined with one or more other such documents, such combination being obvious to a person skilled in the art</p> <p>"&" document member of the same patent family</p>
---	---

Date of the actual completion of the international search 27 March 2013	Date of mailing of the international search report 12/04/2013
---	---

Name and mailing address of the ISA/ European Patent Office, P.B. 5818 Patentlaan 2 NL - 2280 HV Rijswijk Tel. (+31-70) 340-2040, Fax: (+31-70) 340-3016	Authorized officer Veronesi , Sergio
--	--

INTERNATIONAL SEARCH REPORT

International application No

PCT/GB2012/053111

C(Continuation). DOCUMENTS CONSIDERED TO BE RELEVANT

Category*	Citation of document, with indication, where appropriate, of the relevant passages	Relevant to claim No.
A	EP 0 119 978 A2 (MONSANTO CO [US]) 26 September 1984 (1984-09-26) page 14, line 24 - page 15, line 2; figure 4	1-13
A	----- US 5 394 706 A (KEUS ARIE [US]) 7 March 1995 (1995-03-07) page 6, lines 38-60; figures 3-6 -----	1-13

INTERNATIONAL SEARCH REPORT

International application No.
PCT/GB2012/053111

Box No. II Observations where certain claims were found unsearchable (Continuation of item 2 of first sheet)

This international search report has not been established in respect of certain claims under Article 17(2)(a) for the following reasons:

1. Claims Nos.:
because they relate to subject matter not required to be searched by this Authority, namely:

2. Claims Nos.:
because they relate to parts of the international application that do not comply with the prescribed requirements to such an extent that no meaningful international search can be carried out, specifically:

3. Claims Nos.:
because they are dependent claims and are not drafted in accordance with the second and third sentences of Rule 6.4(a).

Box No. III Observations where unity of invention is lacking (Continuation of item 3 of first sheet)

This International Searching Authority found multiple inventions in this international application, as follows:

see additional sheet

1. As all required additional search fees were timely paid by the applicant, this international search report covers all searchable claims.
2. As all searchable claims could be searched without effort justifying an additional fees, this Authority did not invite payment of additional fees.
3. As only some of the required additional search fees were timely paid by the applicant, this international search report covers only those claims for which fees were paid, specifically claims Nos. :
4. No required additional search fees were timely paid by the applicant. Consequently, this international search report is restricted to the invention first mentioned in the claims; it is covered by claims Nos. :

Remark on Protest

- The additional search fees were accompanied by the applicant's protest and, where applicable, the payment of a protest fee.
- The additional search fees were accompanied by the applicant's protest but the applicable protest fee was not paid within the time limit specified in the invitation.
- No protest accompanied the payment of additional search fees.

FURTHER INFORMATION CONTINUED FROM PCT/ISA/ 210

This International Searching Authority found multiple (groups of) inventions in this international application, as follows:

1. claims: 1-36

Device and crystal lisation apparatus

2. claims: 37-42

Crystal lisation process

INTERNATIONAL SEARCH REPORT

Information on patent family members

International application No PCT/GB2012/053111
--

Patent document cited in search report	Publication date	Publication date	Patent family member(s)	Publication date
US 4004886	A	25-01-1977	NONE	

US 2672487	A	16-03-1954	GB 673220 A	04-06-1952
			US 2672487 A	16-03-1954

US 5966966	A	19-10-1999	NONE	

EP 0119978	A2	26-09-1984	CA 1240258 AI	09-08-1988
			DE 3477546 DI	11-05-1989
			EP 0119978 A2	26-09-1984
			JP H0353961 B2	16-08-1991
			JP S59206003 A	21-11-1984

US 5394706	A	07-03-1995	US 5394706 A	07-03-1995
			US 5537832 A	23-07-1996
			US 5575160 A	19-11-1996
