

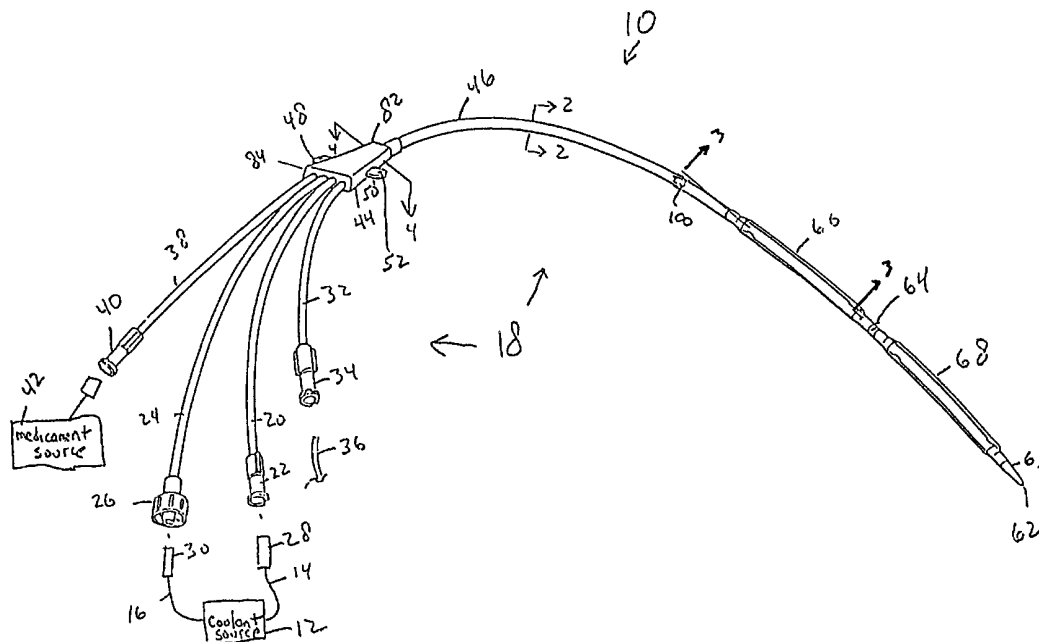

INTERNATIONAL APPLICATION PUBLISHED UNDER THE PATENT COOPERATION TREATY (PCT)

<p>(51) International Patent Classification <sup>7</sup> : <b>A61F 7/12, A61M 25/00, 25/16, 25/18, 39/00, 39/10</b></p>	<p><b>A1</b></p>	<p>(11) International Publication Number: <b>WO 00/66053</b>  (43) International Publication Date: 9 November 2000 (09.11.00)</p>
<p>(21) International Application Number: PCT/US00/12137 (22) International Filing Date: 4 May 2000 (04.05.00)  (30) Priority Data: 09/305,613 5 May 1999 (05.05.99) US  (71) Applicant (for all designated States except US): ALSIUS CORPORATION [US/US]; Suite 150, 15770 Laguna Canyon Road, Irvine, CA 92618 (US).  (72) Inventors; and (75) Inventors/Applicants (for US only): ALIBERTO, Anthony, C. [US/US]; 25842 La Cuesta Avenue, Laguna Hills, CA 92653 (US). EVANS, Scott, M. [US/US]; 1252 Country Hills Drive, Santa Ana, CA 92705 (US). WORTHEN, William, J. [US/US]; 37 Oakbrook, Coto de Caza, CA 92679 (US).  (74) Agent: ALONZO, Arlyn, L.; Alsius Corporation, Suite 150, 15770 Laguna Canyon Road, Irvine, CA 92618 (US).</p>		<p>(81) Designated States: AE, AL, AM, AT, AU, AZ, BA, BB, BG, BR, BY, CA, CH, CN, CR, CU, CZ, DE, DK, DM, EE, ES, FI, GB, GD, GE, GH, GM, HR, HU, ID, IL, IN, IS, JP, KE, KG, KP, KR, KZ, LC, LK, LR, LS, LT, LU, LV, MA, MD, MG, MK, MN, MW, MX, NO, NZ, PL, PT, RO, RU, SD, SE, SG, SI, SK, SL, TJ, TM, TR, TT, TZ, UA, UG, US, UZ, VN, YU, ZA, ZW, ARIPO patent (GH, GM, KE, LS, MW, SD, SL, SZ, TZ, UG, ZW), Eurasian patent (AM, AZ, BY, KG, KZ, MD, RU, TJ, TM), European patent (AT, BE, CH, CY, DE, DK, ES, FI, FR, GB, GR, IE, IT, LU, MC, NL, PT, SE), OAPI patent (BF, BJ, CF, CG, CI, CM, GA, GN, GW, ML, MR, NE, SN, TD, TG).</p> <p><b>Published</b> <i>With international search report.</i></p>

(54) Title: CENTRAL VENOUS CATHETER WITH HEAT EXCHANGE MEMBRANE



(57) Abstract

A central venous catheter (18) includes coolant supply (54), return (56) lumens which communicate coolant to, coolant from first, and second heat exchange membranes (66, 68) arranged along the distal segment of the catheter. The coolant in the heat exchange membranes removes heat from the patient. Additional lumens (58, 60) are provided for conventional central venous catheter uses.

*FOR THE PURPOSES OF INFORMATION ONLY*

Codes used to identify States party to the PCT on the front pages of pamphlets publishing international applications under the PCT.

AL	Albania	ES	Spain	LS	Lesotho	SI	Slovenia
AM	Armenia	FI	Finland	LT	Lithuania	SK	Slovakia
AT	Austria	FR	France	LU	Luxembourg	SN	Senegal
AU	Australia	GA	Gabon	LV	Latvia	SZ	Swaziland
AZ	Azerbaijan	GB	United Kingdom	MC	Monaco	TD	Chad
BA	Bosnia and Herzegovina	GE	Georgia	MD	Republic of Moldova	TG	Togo
BB	Barbados	GH	Ghana	MG	Madagascar	TJ	Tajikistan
BE	Belgium	GN	Guinea	MK	The former Yugoslav Republic of Macedonia	TM	Turkmenistan
BF	Burkina Faso	GR	Greece	ML	Mali	TR	Turkey
BG	Bulgaria	HU	Hungary	MN	Mongolia	TT	Trinidad and Tobago
BJ	Benin	IE	Ireland	MR	Mauritania	UA	Ukraine
BR	Brazil	IL	Israel	MW	Malawi	UG	Uganda
BY	Belarus	IS	Iceland	MX	Mexico	US	United States of America
CA	Canada	IT	Italy	NE	Niger	UZ	Uzbekistan
CF	Central African Republic	JP	Japan	NL	Netherlands	VN	Viet Nam
CG	Congo	KE	Kenya	NO	Norway	YU	Yugoslavia
CH	Switzerland	KG	Kyrgyzstan	NZ	New Zealand	ZW	Zimbabwe
CI	Côte d'Ivoire	KP	Democratic People's Republic of Korea	PL	Poland		
CM	Cameroon	KR	Republic of Korea	PT	Portugal		
CN	China	KZ	Kazakstan	RO	Romania		
CU	Cuba	LC	Saint Lucia	RU	Russian Federation		
CZ	Czech Republic	LI	Liechtenstein	SD	Sudan		
DE	Germany	LK	Sri Lanka	SE	Sweden		
DK	Denmark	LR	Liberia	SG	Singapore		
EE	Estonia						

-1-

**CENTRAL VENOUS CATHETER WITH HEAT EXCHANGE MEMBRANE****RELATED APPLICATION**

Priority is claimed from co-pending U.S. patent application serial no. 09/253,109, filed February 19, 1999.

**FIELD OF THE INVENTION**

The present invention relates generally to methods and apparatus for cooling patients for therapeutic purposes, and more particularly to systems for establishing central venous access while providing a means for cooling a patient.

**BACKGROUND**

It has been discovered that the medical outcome for a patient suffering from severe brain trauma or from ischemia caused by stroke or heart attack is degraded if the patient's body temperature rises above normal (38°C). It is further believed that the medical outcome for many such patients might be significantly improved if the patients were to be cooled relatively quickly for a short period, e.g., 24-72 hours. Apart from the therapeutic benefits of hypothermia, the outcomes for brain trauma or ischemia patients that develop fevers is worse than for patients that do not develop fevers. Consequently, temperature management for such patients is important, even when hypothermia is not to be used to treat the patients. Moreover, prophylactic short-term hypothermia might help patients undergoing minimally invasive heart surgery and aneurysm surgery.

-2-

The affected organ, in any case, is the brain. Accordingly, systems and methods have been disclosed that propose cooling blood flowing to the brain through the carotid artery. An example of such systems and methods is disclosed in co-pending U.S. pat. app. serial no. 09/063,984, filed April 21, 1998, owned by the present assignee and incorporated herein by reference. In the referenced application, various catheters are disclosed which can be advanced into a patient's carotid artery and through which coolant can be pumped in a closed circuit, to remove heat from the blood in the carotid artery and thereby cool the brain. The referenced devices have the advantage over other methods of cooling (e.g., wrapping patients in cold blankets) of being controllable, relatively easy to use, and of being capable of rapidly cooling and maintaining blood temperature at a desired set point.

As recognized in co-pending U.S. pat. app. serial no. 09/133,813, filed August 13, 1998, owned by the present assignee and incorporated herein by reference, the above-mentioned advantages in treating brain trauma/ischemic patients by cooling can also be realized by cooling the patient's entire body, i.e., by inducing systemic hypothermia. The advantage of systemic hypothermia is that, as recognized by the present assignee, to induce systemic hypothermia a cooling catheter or other cooling device need not be advanced into the blood supply of the brain, but rather can be easily and quickly placed into the relatively large vena cava of the central venous system.

Moreover, since many patients already are intubated with central venous catheters for other clinically approved purposes anyway, providing a central venous catheter that can also cool the blood, if only to manage temperature and thereby ameliorate fever spikes, requires no additional surgical procedures for those patients. A cooling central venous

-3-

catheter is disclosed in the present assignee's co-pending U.S. patent application serial no. 09/253,109, filed February 19, 1999 and incorporated herein by reference. The present invention is directed to such a device.

### **SUMMARY OF THE INVENTION**

A heat exchange catheter, preferably made of urethane, includes a catheter body defining at least a coolant supply lumen and a coolant return lumen. First and second heat exchange membranes are disposed along a distal portion of the catheter body, and the heat exchange membranes communicate with one or more of the lumens. With this structure, coolant can be supplied to the heat exchange membranes via the coolant supply lumen and received from the heat exchange membranes via the coolant return lumen to effect a closed loop heat exchanger for cooling and/or warming a patient.

Preferably, the first and second heat exchange membranes define first and second interiors respectively communicating with first and second coolant supply ports in the coolant supply lumen. Also, first and second coolant return ports are formed in the coolant return lumen, and coolant flows from the heat exchange membranes through the return ports. At least one anchor can be engaged with the catheter body to fasten the catheter to a patient.

In addition to the coolant supply and return lumens, the catheter can define a drug delivery lumen and a guide wire lumen. A connector manifold can be engaged with the catheter body to interconnect the lumens with respective connector lines. More specifically, the connector manifold defines plural channels, and each channel

-4-

establishes a respective pathway for fluid communication between a respective connector line and a respective lumen. As set forth in detail below, the anchor is on the connector manifold.

To provide for infusing medicament into a patient while simultaneously cooling the patient, at least one drug delivery port is formed in the catheter body. Preferably, the drug delivery port is formed at a location that is between two adjacent heat exchange membranes to establish a pathway for fluid communication from the drug delivery lumen to a location outside the catheter body. If desired, additional drug delivery ports can be formed along the length of the catheter.

In another aspect, a method for making a heat exchange catheter includes disposing a multi-lumen catheter body in a connector manifold mold, and disposing plural connector tubes in the connector manifold mold. Also, the method includes interconnecting a respective lumen with a respective connector tube using a mandrel, and then directing a plastic material into the connector manifold mold. The mandrels are then removed, such that a respective channel is defined between each respective lumen and its connector line.

In another aspect, a method is disclosed for treating a patient. The method includes advancing a heat exchange catheter device into the patient, and then circulating coolant through the catheter device while preventing infusion of the coolant directly into the patient's bloodstream. Per the present invention, the catheter device includes a heat exchange region that is established by: one or more heat exchange membranes, or one or more hollow fibers, or one or more chamber-defining enclosures.

-5-

In still another aspect, a catheter configured as a Swan-Ganz catheter or central venous catheter has at least one balloon-like membrane distally located on the catheter for heating or cooling blood in a patient. More particularly, the membrane defines an interior communicating with a coolant supply lumen of the catheter and with a coolant return lumen of the catheter, to circulate coolant through the interior of the membrane.

The details of the present invention, both as to its structure and operation, can best be understood in reference to the accompanying drawings, in which like reference numerals refer to like parts, and in which:

#### **BRIEF DESCRIPTION OF THE DRAWINGS**

Figure 1 is a perspective view of the present cooling catheter, schematically showing a medicament source and coolant source in an exploded relationship with the catheter;

Figure 2 is a cross-sectional view as seen along the line 2-2 in Figure 1;

Figure 3 is a cross-sectional view as seen along the line 3-3 in Figure 1; and

Figure 4 is a top view of the interior of the connector manifold, as seen along the line 4-4 in Figure 1.

#### **DETAILED DESCRIPTION OF THE PREFERRED EMBODIMENT**

Referring initially to Figure 1, a therapeutic catheter system, generally designated 10, is shown for establishing and maintaining hypothermia in a patient, or for attenuating a fever spike in a patient and then maintaining normal body temperature in the patient. Commencing the description of the system 10 at the proximal end, as shown the system 10

-6-

includes a cooling source 12 that can be a water-bath system or a TEC-based system such as either of the systems disclosed in co-pending U.S. patent application serial no. 09/220,897, filed December 24, 1998 and incorporated herein by reference, or U.S. patent application serial no. 09/260,950, filed March 2, 1999, also incorporated herein by reference.

In any case, the coolant source provides coolant such as saline through a coolant supply line 14, and coolant is returned to the source 12 via a coolant return line 16. A catheter, generally designated 18, includes a source tube 20 terminating in a fitting such as a female luer fitting 22. Also, the catheter 18 has a return tube 24 terminating in a fitting such a male luer fitting 26. The fittings 22, 26 can be selectively engaged with complementary fittings 28, 30 of the lines 14, 16 to establish a closed circuit coolant path between the catheter 18 and coolant source 12.

Additionally, the catheter 18 includes a guide wire and primary infusion tube 32 that terminates in a fitting such as a female luer 34. A guide wire 36 can be advanced through the tube 32 in accordance with central venous catheter placement principles, or medicament or other fluid can be infused through the guide wire and primary infusion tube 32. Moreover, a secondary infusion tube 38 with female luer fitting 40 can be selectively engaged with a medicament source 42 for infusing fluid from the source 42 through the secondary tube 38.

As discussed further below, the tubes 20, 24, 32, 38 are held in a distally-tapered connector manifold 44. As also set forth further below, the connector manifold 44 establishes respective pathways for fluid communication between the tubes 20, 24, 32, 38 and respective lumens in a catheter body 46.



-7-

A suture anchor 48 advantageously is formed on the connector manifold 44 for suturing the catheter 18 to a patient in accordance with central venous catheter operating principles. In one intended environment, the suture anchor 48 includes opposed ears 50 formed with respective suture holes 52. Other equivalent anchor structure can be used to hold the catheter 18 onto the patient, however, including surgical tape. When the catheter is a so-called Swan-Ganz catheter, i.e., a catheter of the type disclosed in U.S. Patent No. 3,995,623, incorporated herein by reference, the anchor 48 typically would not be provided.

In cross-reference to Figures 1 and 2, the catheter body 46 includes at least two lumens, and in the preferred embodiment the catheter body 46 includes at least four lumens. More specifically, the catheter body 46 defines a generally wedge- or triangular-shaped (in the transverse cross-section shown) coolant supply lumen 54, a generally wedge-shaped coolant return lumen 56, a round guide wire lumen 58, and a wedge-shaped secondary infusion lumen 60. As mentioned above, however, the catheter can be a Swan-Ganz catheter, in which case additional lumens can be provided for Swan-Ganz catheter applications, including a lumen for inflating an anchoring balloon for holding the distal tip of the catheter in an appropriate blood vessel for various heart-related measurements and another lumen for holding a wire or wires that are attached to one or more distally-located sensors, such as temperature sensors, pressure sensors, gas sensors, and electrical sensors.

In any case, the connector manifold 44 establishes a pathway for fluid communication between the coolant supply tube 20 and the coolant supply lumen 54. Likewise, the connector manifold 44 establishes a pathway for fluid communication between

-8-

the coolant return tube 24 and the coolant return lumen 56. Further, the connector manifold 44 establishes a pathway for fluid communication between the guide wire and primary infusion tube 32, and the guide wire lumen 58, which terminates at an open distal hole 62 defined by a distally tapered and chamfered distal tip 63 of the catheter body 46. Also, the connector manifold 44 establishes a pathway for fluid communication between the secondary infusion tube 38 and the secondary infusion lumen 60, which terminates at an infusion port 64 in a distal segment of the catheter body 46. Additional ports can be provided for each lumen 58, 60 along the length of the catheter.

Referring now to Figures 1 and 3, at least proximal and distal thin-walled heat exchange membranes 66, 68 are arranged along the last fifteen or so centimeters of the catheter body 46 and are bonded to the outer surface of the catheter body 46, with the infusion port 64 being located between the heat exchange membranes 66, 68. Thus, each heat exchange membrane is about six centimeters to seven and one-half centimeters in length, with the heat exchange membranes being longitudinally spaced from each other along the catheter body 46 in the preferred embodiment shown. Essentially, the heat exchange membranes 66, 68 extend along most or all of that portion of the catheter 46 that is intubated within the patient. The heat exchange membranes can be established by a medical balloon material.

The heat exchange membranes 66, 68 can be inflated with coolant from the coolant source 12 as supplied from the coolant supply lumen 54, and coolant from the heat exchange membranes 66, 68 is returned via the coolant return lumen 56 to the coolant source 12. In their inflated configurations, the heat exchange membranes define a diameter

of about ten French, and preferably no more than twelve French. Thus, the heat exchange membranes 66, 68 are relatively long and comparatively thin, to advantageously avoid excessively blocking blood flow through the vena cava while nevertheless effecting patient cooling.

As shown in Figure 3, a wall 70 separates the coolant supply and return lumens 54, 56. Taking the proximal heat exchange membrane 66 as an example, a supply port 72 is formed in the catheter body 46 through which coolant from the supply lumen 54 can flow into the interior 74 of the heat exchange membrane 66, as indicated by the arrows 76. Moreover, a return port 78 is formed in the catheter body 46, and coolant can flow out of the heat exchange membrane 66 through the return port 78 and into the return lumen 56, as indicated by the arrows 80. As can be appreciated in reference to Figure 3, for each heat exchange membrane 66, 68, the respective coolant supply port is distal to the respective coolant return port, to optimize fluid flow and heat transfer, although if desired the direction of fluid flow can be in the opposite direction. Both the coolant supply and coolant return lumens 54, 56 terminate proximal to the distal tip 63. For example, the coolant return lumen 56 can terminate just distal of the coolant return port for the distal heat exchange membrane 68, and the coolant supply lumen can terminate just distal of the coolant supply port of the distal heat exchange membrane 68.

In any case, it may now be appreciated that coolant is circulated through the catheter device 18 in a closed loop. That is, infusion of the coolant directly into the patient's bloodstream is prevented. As detailed above, the catheter device includes a heat exchange region established by one or more heat exchange membranes.

-10-

Alternatively, the heat exchange region can be established by or one or more hollow fibers, or one or more chamber-defining enclosures, such as metal or plastic bellows-type enclosures.

In the preferred embodiment, the components of the catheter 18 are made of urethane, and more preferably are made of an aromatic, polyether-based polyurethane, although other suitable materials can be used. In a specific embodiment, the tubes 20, 24, 32, 38 are made of Tecothane TT-1095A made by Thermedics, Inc. of Woburn, MA. Also, the heat exchange membranes 66, 68 are made of Pellethane 2363-65D, made by Dow Chemical Corp. In contrast, the catheter body 46 is made of Tecothane TT-2055D-B20 with Barium Sulfate radiopacifying agent incorporated into the polymer matrix for optimum visualizing during fluoroscopic maneuvering to a desired location. The catheter 18 can be coated with an anti-microbial agent and an anti-clotting agent if desired.

Now referring to Figure 4, the details of the connector manifold 44 can be seen. As shown, the preferred connector manifold 44 is flat and wedge-shaped, with the distal end 82 of the connector manifold 44 being narrower than the proximal end 84. Within the connector manifold 44, plural channels 86 are established. As can be appreciated in reference to Figure 4, each channel 86 establishes a respective pathway for fluid communication between a respective connector line 20, 24, 32, 38 and a respective lumen 54, 56, 58, 60. Owing to the wedge shape of the connector manifold 44, the tubes 20, 24, 32, 38 are closely juxtaposed to each other near the distal end 82 of the connector manifold 44.

In making the connector manifold 44, the tubes 20, 24, 32, 38 are positioned on

-11-

what will become the interior of the connector manifold, and the catheter body 46 likewise is positioned on the connector manifold, closely spaced from the distal ends of the tubes. A respective mandrel is then advanced into each tube and the lumen of the catheter body 46 that is to communicate with the tube. Next, plastic is directed over and around the tubes, mandrels, and catheter body 46 by insert molding. The mandrels are removed after the plastic hardens, establishing the channels 86.

As envisioned by the present invention, the structure set forth above can be used in many medical applications to cool a patient and/or to maintain temperature in a normothermic or hypothermic patient, for purposes of improving the medical outcomes of patients on whom, e.g., aneurysm surgery is to be performed, preferably while the patient's temperature is below normal body temperature. The structure can then be used to rewarm the patient in a controlled manner by circulating warm coolant through the structure, or by otherwise regulating natural body rewarming by circulating coolant that is maintained at an appropriate cool (relative to normal body temperature) or warm (relative to normal body temperature) temperature through the structure.

As another example, head trauma can be treated by and after lowering and maintaining the patient's temperature below normal body temperature. Or, cardiac arrest can be treated while the patient's temperature is below normal body temperature. Yet again, minimally invasive heart surgery can be performed on the patient while the patient's temperature is below normal body temperature. And, cardiac arrest in the patient can be treated by and while the patient's temperature is below normal body temperature. Also, the present invention understands that for certain patients, e.g.,

-12-

stroke victims, it is important to maintain the temperature of a patient at or below normal body temperature, when the patient runs or attempts to run a fever. For severe ischemic stroke victims, the malady can be treated by maintaining the patient's body temperature at a hypothermic level.

If desired, a temperature sensor 100 such as a thermistor or other suitable device can be attached to the catheter 18 as shown. The sensor 100 can be mounted on the catheter 18 by solvent bonding at a point that is proximal to the membranes 66, 68. Or, the sensor 100 can be disposed in a lumen of the catheter 18, or attached to a wire that is disposed in a lumen of the catheter 18, with the sensor hanging outside the catheter 18. Alternatively, a separate temperature probe can be used, such as the esophageal probe disclosed in co-pending U.S. patent application serial no. 09/282,971, filed March 31, 1999 and incorporated herein by reference. As yet another alternative, a rectal probe or tympanic temperature sensor can be used. In any case, the sensor is electrically connected to the coolant source 12 for control of the temperature of the coolant as described in the above-referenced '897 and '940 applications.

While the particular CENTRAL VENOUS CATHETER WITH HEAT EXCHANGE MEMBRANE as herein shown and described in detail is fully capable of attaining the above-described objects of the invention, it is to be understood that it is the presently preferred embodiment of the present invention and is thus representative of the subject matter which is broadly contemplated by the present invention, that the scope of the present invention fully encompasses other embodiments which may become obvious to those skilled in the art, and that the scope of the present invention is accordingly to be limited by nothing other than the

-13-

appended claims, in which reference to an element in the singular is not intended to mean "one and only one" unless explicitly so stated, but rather "one or more". All structural and functional equivalents to the elements of the above-described preferred embodiment that are known or later come to be known to those of ordinary skill in the art are expressly incorporated herein by reference and are intended to be encompassed by the present claims. Moreover, it is not necessary for a device or method to address each and every problem sought to be solved by the present invention, for it to be encompassed by the present claims. Furthermore, no element, component, or method step in the present disclosure is intended to be dedicated to the public regardless of whether the element, component, or method step is explicitly recited in the claims. No claim element herein is to be construed under the provisions of 35 U.S.C. 112, sixth paragraph, unless the element is expressly recited using the phrase "means for".

**WHAT IS CLAIMED IS:**

1. A heat exchange catheter, comprising:  
a catheter body defining at least a coolant supply lumen and a coolant return lumen;  
at least first and second heat exchange membranes disposed along a distal portion of the catheter body and communicating with one or more of the lumens, such that coolant can be supplied to the heat exchange membranes via the coolant supply lumen and received from the heat exchange membranes via the coolant return lumen to effect a closed loop heat exchanger for cooling and/or warming a patient.
2. The catheter of Claim 1, wherein the first and second heat exchange membranes define first and second interiors respectively communicating with at least first and second coolant supply ports in the coolant supply lumen and at least first and second coolant return ports in the coolant return lumen.
3. The catheter of Claim 2, wherein the catheter is made of a urethane.
4. The catheter of Claim 1, further comprising at least one anchor engaged with the catheter body.
5. The catheter of Claim 1, wherein the catheter defines at least a drug delivery lumen.



6. The catheter of Claim 5, wherein the catheter defines at least a guide wire lumen.

7. The catheter of Claim 6, further comprising a connector manifold engaged with the catheter body and interconnecting the lumens with respective connector lines.

8. The catheter of Claim 7, wherein the anchor is on the connector manifold.

9. The catheter of Claim 8, wherein the connector manifold defines plural channels, each channel establishing a respective pathway for fluid communication between a respective connector line and a respective lumen.

10. The catheter of Claim 9, wherein at least one drug delivery port is formed in the catheter body at a location that is between two adjacent heat exchange membranes to establish a pathway for fluid communication from the drug delivery lumen to a location outside the catheter body.

11. A method for making a heat exchange catheter device, comprising the acts of:

disposing a multi-lumen catheter body in a connector manifold mold;

disposing plural connector tubes in the connector manifold mold;

-16-

interconnecting a respective lumen with a respective connector tube using a mandrel;

directing a plastic material into the connector manifold mold; and

removing the mandrels such that a respective channel is defined between each respective lumen and its connector tube.

12. The method of Claim 11, further comprising the act of engaging at least one heat exchange membrane with a distal segment of the catheter body.

13. The method of Claim 12, wherein the catheter body is made of urethane.

14. A method for treating a patient, comprising the acts of:  
advancing a heat exchange catheter device into the patient; and  
circulating coolant through the catheter device while preventing infusion of the coolant directly into the patient's bloodstream, the catheter device including a heat exchange region established by: one or more heat exchange membranes, or one or more hollow fibers, or one or more chamber-defining enclosures.

15. The method of Claim 14, further comprising the act of performing aneurysm surgery while the patient's temperature is below normal body temperature.

16. The method of Claim 14, further comprising the act of treating head

-17-

trauma in the patient while the patient's temperature is below normal body temperature.

17. The method of Claim 14, further comprising the act of treating cardiac arrest in the patient while the patient's temperature is below normal body temperature.

18. The method of Claim 14, further comprising the act of performing minimally invasive heart surgery on the patient while the patient's temperature is below normal body temperature.

19. The method of Claim 14, further comprising the act of treating cardiac malady in the patient while the patient's temperature is below normal body temperature.

20. The method of Claim 14, further comprising the act of maintaining the temperature of a patient at or below normal body temperature, when the patient runs or attempts to run a fever.

21. The method of Claim 14, further comprising the act of treating ischemic stroke in the patient while the patient's temperature is below normal body temperature.

22. The catheter of Claim 1, further comprising a temperature sensor attached to the catheter body.

-18-

23. The catheter of Claim 3, wherein the urethane is an aromatic urethane.

24 A catheter configured as a Swan-Ganz catheter or central venous catheter having at least one membrane distally located on the catheter for heating or cooling blood in a patient.

25 The catheter of Claim 24 wherein the membrane defines an interior communicating with a coolant supply lumen of the catheter and with a coolant return lumen of the catheter, to circulate coolant through the interior for heating or cooling a patient.

Fig. 1

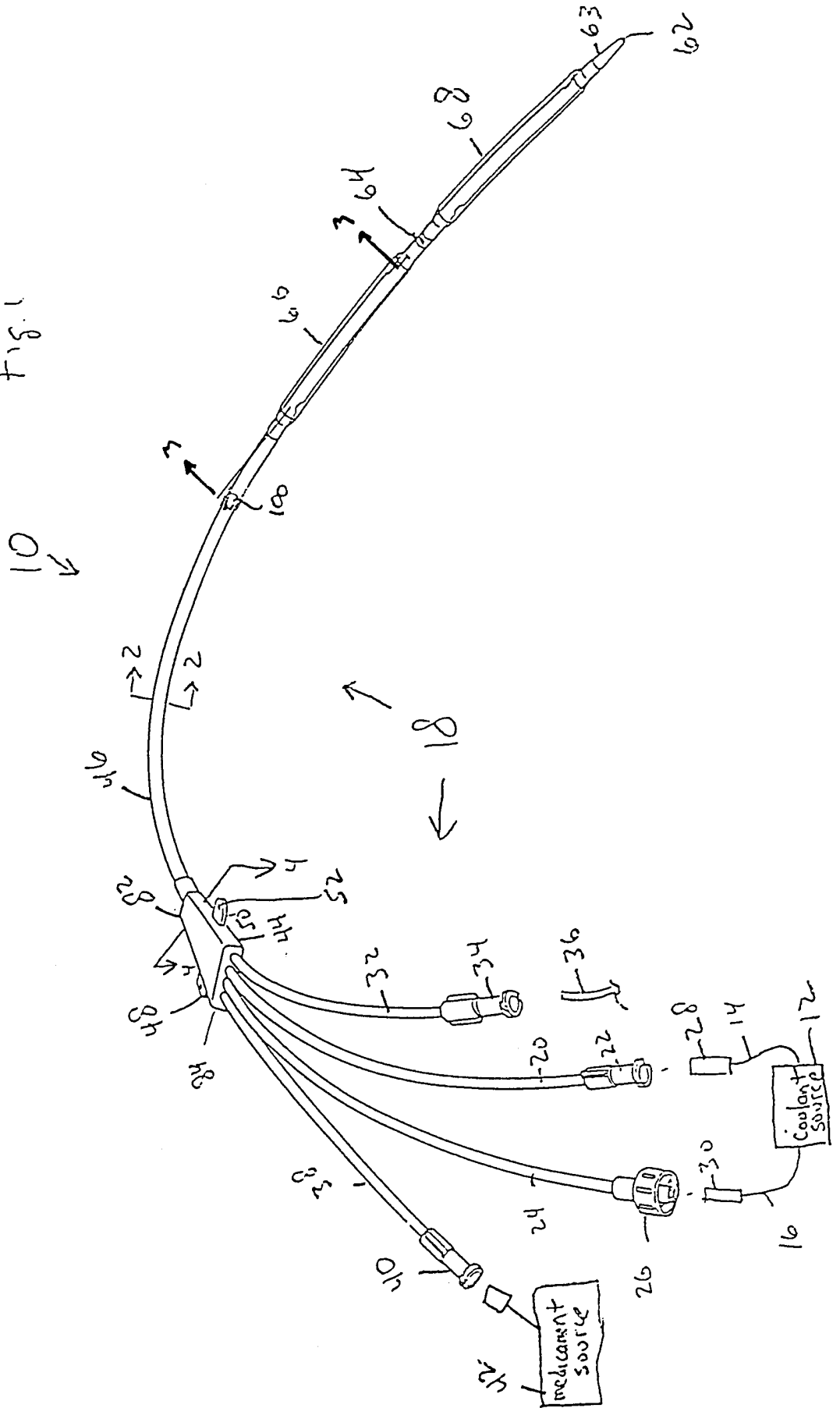

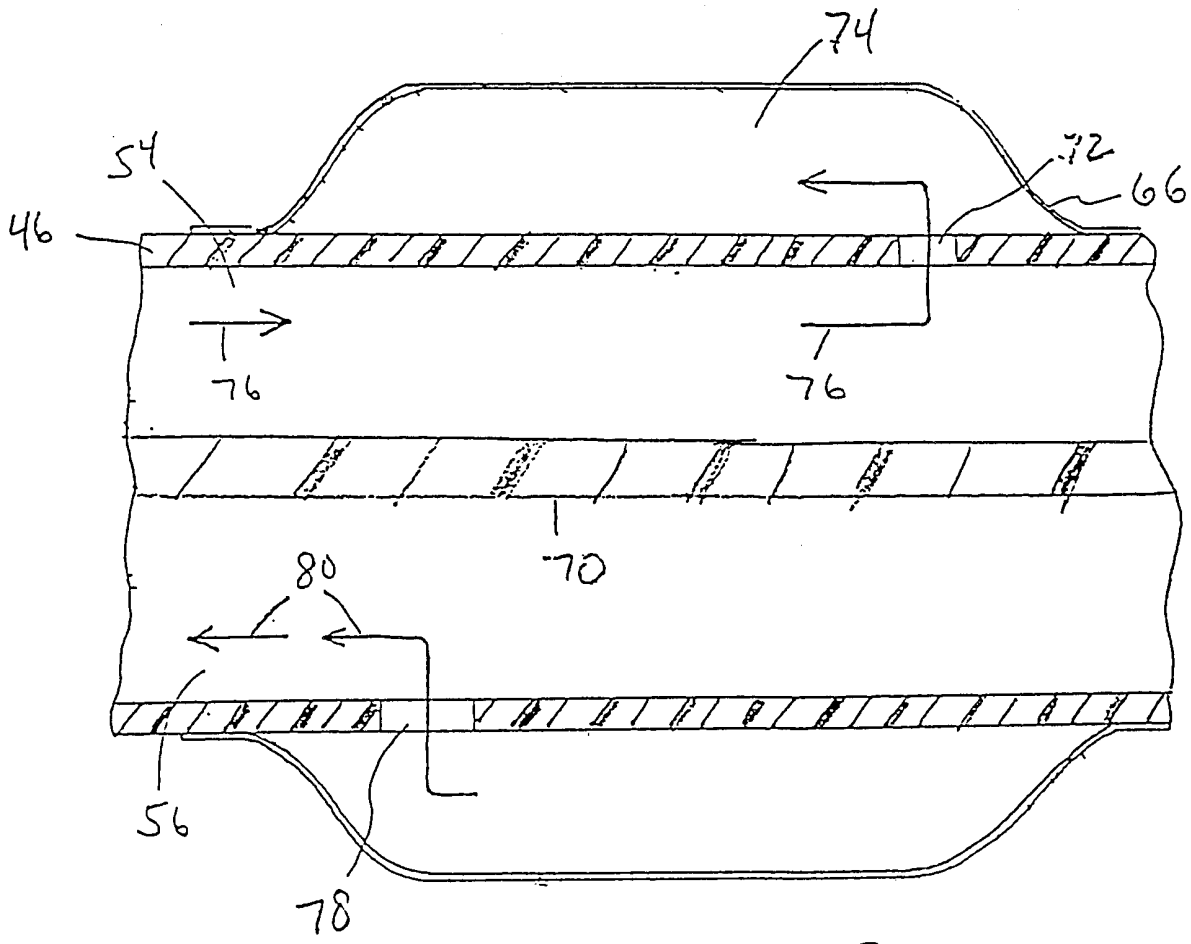

Fig.3

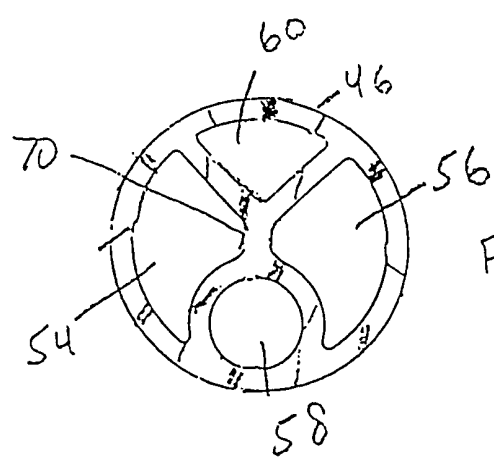

Fig.2

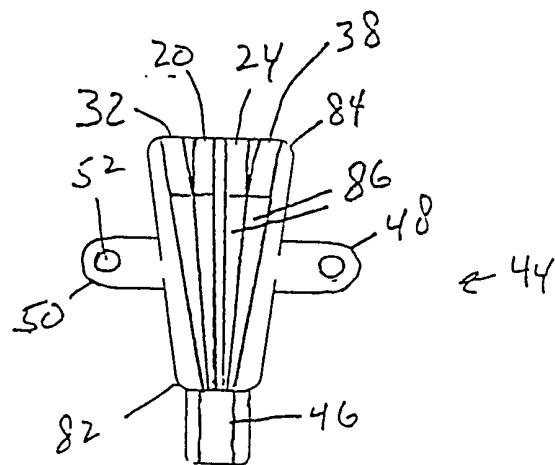

Fig. 4

# INTERNATIONAL SEARCH REPORT

International application No.  
PCT/US00/12137

<b>A. CLASSIFICATION OF SUBJECT MATTER</b> IPC(7) : A61F 7/12; A61M 25/00, 16, 18, 39/00, 10 US CL : 604/ 113, 523, 533; 606/21 According to International Patent Classification (IPC) or to both national classification and IPC		
<b>B. FIELDS SEARCHED</b> Minimum documentation searched (classification system followed by classification symbols) U.S. : 604/43, 113, 114, 523-536, 905; 606/20-24, 27, 28; 31/ 607/96, 104, 105, 113 Documentation searched other than minimum documentation to the extent that such documents are included in the fields searched Electronic data base consulted during the international search (name of data base and, where practicable, search terms used)		
<b>C. DOCUMENTS CONSIDERED TO BE RELEVANT</b>		
Category*	Citation of document, with indication, where appropriate, of the relevant passages	Relevant to claim No.
X	US 5,624,392 A (SAAB) 29 April 1997, entire document.	1-25
X	US 5,549,559 A (ESHEL) 27 August 1996, entire document.	1-25
A	US 5,879,347 A (SAADAT) 09 March 1999, entire document.	1-25
A	US 5,451,208 A (GOLDRATH) 19 September 1995, entire document.	1-25
A	US 5,405,322 A (LENNOX et al.) 11 April 1995, entire document.	1-25
<input type="checkbox"/> Further documents are listed in the continuation of Box C. <input type="checkbox"/> See patent family annex.		
* Special categories of cited documents:	*T* later document published after the international filing date or priority date and not in conflict with the application but cited to understand the principle or theory underlying the invention	
*A* document defining the general state of the art which is not considered to be of particular relevance	*X* document of particular relevance; the claimed invention cannot be considered novel or cannot be considered to involve an inventive step when the document is taken alone	
*E* earlier document published on or after the international filing date	*Y* document of particular relevance; the claimed invention cannot be considered to involve an inventive step when the document is combined with one or more other such documents, such combination being obvious to a person skilled in the art	
*L* document which may throw doubts on priority claim(s) or which is cited to establish the publication date of another citation or other special reason (as specified)	*&* document member of the same patent family	
*O* document referring to an oral disclosure, use, exhibition or other means		
*P* document published prior to the international filing date but later than the priority date claimed		
Date of the actual completion of the international search  14 JULY 2000	Date of mailing of the international search report  <b>23 AUG 2000</b>	
Name and mailing address of the ISA/US Commissioner of Patents and Trademarks Box PCT Washington, D.C. 20231 Facsimile No. (703) 305-3230	Authorized officer <i>R. K. Stright, Jr.</i> RONALD K. STRIGHT, JR. Telephone No. (703) 308-2113	