

(19)



SUOMI - FINLAND

(FI)

PATENTTI- JA REKISTERIHALLITUS

PATENT- OCH REGISTERSTYRELSEN

FINNISH PATENT AND REGISTRATION OFFICE

(10) **FI 128980 B**
(12) **PATENTTIJULKAISU**
PATENTSKRIFT
PATENT SPECIFICATION

(45) Patentti myönnetty - Patent beviljats - Patent granted **30.04.2021**

(51) Kansainvälinen patenttiluokitus - Internationell patentklassifikation -
International patent classification

B62M 27/00 (2006.01)

B62B 13/06 (2006.01)

B62K 3/00 (2006.01)

B62M 6/00 (2010.01)

B62B 13/16 (2006.01)

(21) Patenttihakemus - Patentansökning - Patent application 20206119

(22) Tekemispäivä - Ingivningsdag - Filing date **06.11.2020**

(23) Saapumispäivä - Ankomstdag - Reception date **06.11.2020**

(43) Tullut julkiseksi - Blivit offentlig - Available to the public **30.04.2021**

(73) Haltija - Innehavare - Proprietor
1 •Arctic Rides Oy, Leppäpiha 1, 90830 HAUKIPUDAS, SUOMI - FINLAND, (FI)

(72) Keksijä - Uppfinnare - Inventor
1 •Laatikainen, Markku, HAUKIPUDAS, SUOMI - FINLAND, (FI)

(74) Asiamies - Ombud - Agent
Kolster Oy Ab, Salmisaarenaukio 1, 00180 Helsinki

(54) Keksinnön nimitys - Uppfinningens benämning - Title of the invention
Lumikulkuneuvo
Snöfordon
Snow vehicle

(56) Viitejulkaisut - Anförda publikationer - References cited
GB 2195298 B, US 4087106 A, WO 2016170364 A1,
Sähköpotkukelkka electric kick-sled YouTube [online] [video] 26.1.2014, retrieved on 2021-02-02 from
[HTTPS://WWW.YOUTUBE.COM/WATCH?V=QSRXPXRG15Q](https://www.youtube.com/watch?v=QSRXPXRG15Q)

(57) Tiivistelmä - Sammandrag - Abstract

Lumiajoneuvo (100) tuodaan ilmi. Se sisältää: jalasparin (102, 104); sähkömoottorin (106); vetorenkaan (108), jolle käyttövoiman antaa sähkömoottori (106), ja joka on konfiguroitu saamaan aikaan käyttövoiman lumiajoneuvolle (100); istuimen (114), joka on asetettu vetorenkaan (108) yläpuolelle, ja joka on konfiguroitu ottamaan henkilö matkustajaksi; ja ohjausjärjestelyn, joka käsittää ohjausakselin (122), joka on kytketty vetorenkaaseen (108), korkeaan tasoon asetetun ohjaustangon (124), joka on kytketty ohjausakseliin (122), ja joka on konfiguroitu ja asetettu mahdollistamaan vetorenkaan (108) ohjaaminen ajajan seisoessa jalasparilla (102, 104), ja istuimen tasoon asetetun ohjaustangon (128), joka on kytketty ohjausakseliin (122), ja joka on konfiguroitu ja asetettu mahdollistamaan vetorenkaan (122) ohjaaminen ajajan istuessa istuimella (114).

Snow vehicle (100) is disclosed. It includes: a pair of runners (102, 104); an electric motor (106); a traction wheel (108), powered by the electric motor (106), and configured to cause a propulsion for the snow vehicle (100); a seat (114) positioned above the traction wheel (108) and configured to accommodate a person; and a steering arrangement comprising a steering axle (122) coupled with the traction wheel (108), a handlebar-level steering bar (124) coupled with the steering axle (122) and configured and positioned to enable steering of the traction wheel (108) while a driver is standing on the pair or runners (102, 104), and a seatlevel steering bar (128) coupled with the steering axle (122) and configured and positioned to enable steering of the traction wheel (108) while a driver is sitting on the seat (114).

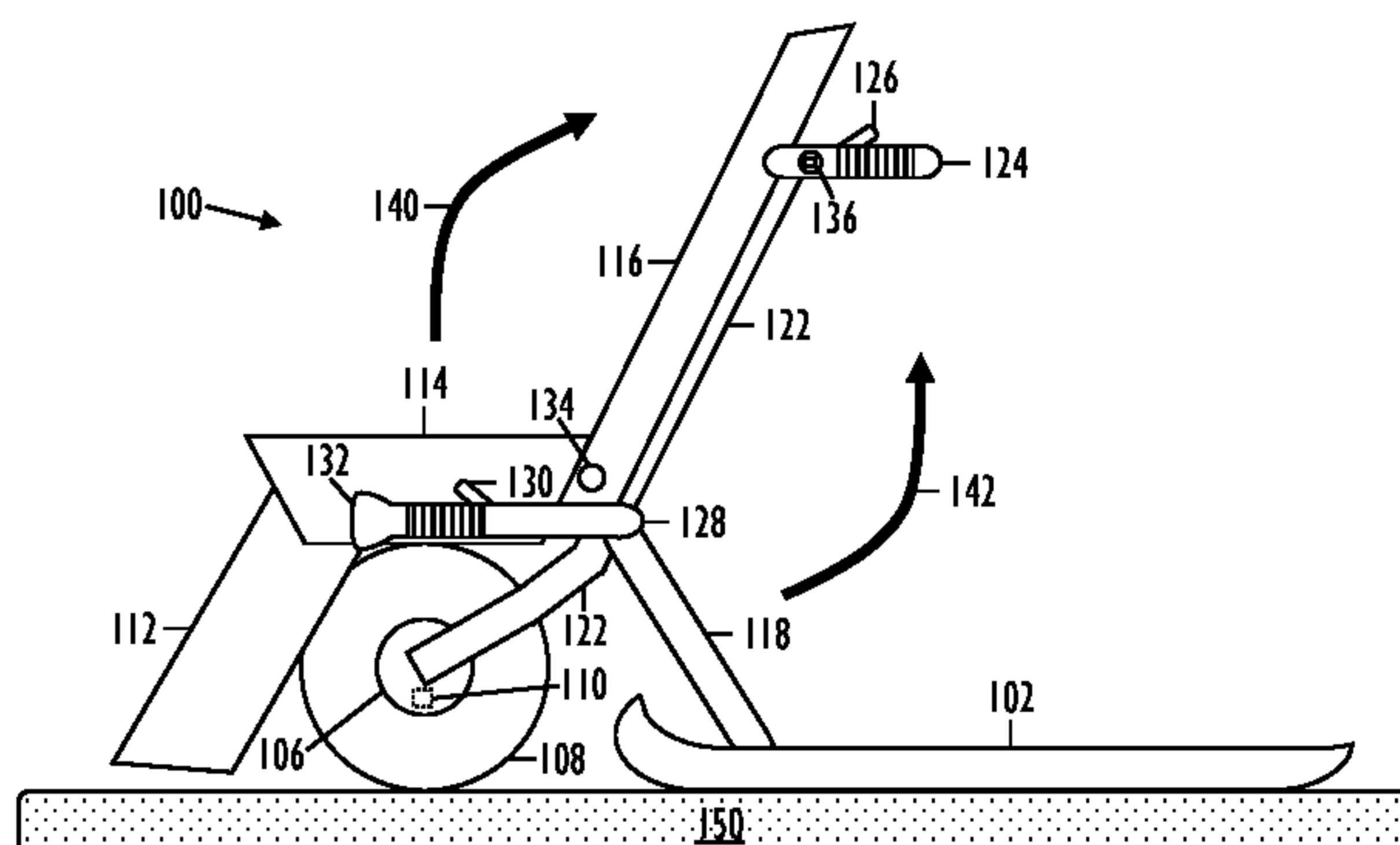

SNOW VEHICLE

FIELD

Various embodiments relate to a snow vehicle.

BACKGROUND

5 Natural resources and climate necessitate new solutions for travelling, especially over short distances. E-bikes (or electric bikes), e-scooters and the like are emerging. However, almost 30% of world population lives in areas with a true winter having snow and ice. Naturally, snowmobiles have existed for a long time, but they are too fast, dangerous and expensive for everyday use on common
10 pavements and roads. Consequently, a tremendous need exists for an everyday vehicle capable of safely and reliably transporting people and goods in snowy and icy conditions.

GB 2195298 B discloses a vehicle resembling a kicksled and employing a motor. US 4,087,106 discloses a three-point contact cambering vehicle with
15 wheels, or alternatively with ice skates or snow skis. WO 2016/170364 A1 discloses a reconfigurable wheeled personal mobility device. On the Internet, various hobbyists also provide motorized kicksleds, but they are rather designed for motorsports and high speeds. An everyday-like motorized kicksled is disclosed in various online videos such as in a Sähköpotkukelkka electric kicksled
20 YouTube video: <https://www.youtube.com/watch?v=QSRXpXrG15Q>. A more sophisticated and safe snow vehicle is clearly desirable.

BRIEF DESCRIPTION

According to an aspect, there is provided subject matter of independent claims. Dependent claims define some embodiments.

25 One or more examples of implementations are set forth in more detail in the accompanying drawings and the description of embodiments.

LIST OF DRAWINGS

Some embodiments will now be described with reference to the accompanying drawings, in which

30 FIG. 1 is a side view illustrating embodiments of a snow vehicle;
FIG. 2 is a top view illustrating embodiments of a snow vehicle;
FIG. 3 illustrates embodiments of a steering arrangement;
FIG. 4 and FIG. 5 illustrates embodiments of a footrest;

FIG. 6 illustrates an embodiment providing extra wheels;
FIG. 7 illustrates an embodiment with a toboggan;
FIG. 8, FIG. 9, FIG. 10, FIG. 11, FIG. 12 and FIG. 13 illustrate various use cases.

5 DESCRIPTION OF EMBODIMENTS

The following embodiments are only examples. Although the specification may refer to "an" embodiment in several locations, this does not necessarily mean that each such reference is to the same embodiment(s), or that the feature only applies to a single embodiment. Single features of different
10 embodiments may also be combined to provide other embodiments. Furthermore, words "comprising" and "including" should be understood as not limiting the described embodiments to consist of only those features that have been mentioned and such embodiments may contain also features/structures that have not been specifically mentioned.

15 Reference numbers, both in the description of the embodiments and in the claims, serve to illustrate the embodiments with reference to the drawings, without limiting it to these examples only.

The embodiments and features, if any, disclosed in the following description that do not fall under the scope of the independent claims are to be
20 interpreted as examples useful for understanding various embodiments of the invention.

Let us study a snow vehicle 100 with reference to FIG. 1 providing a side view and FIG. 2 providing a top view.

25 The snow vehicle 100 comprises a pair of runners 102, 104 configured to support the snow vehicle 100 travelling over snow and/or ice 150. As shown in FIG. 2, the pair of runners 102, 104 are placed side by side, so that a driver of the snow vehicle 100 may stand on the pair of runners 102, 104, one foot on each.

In an embodiment, the pair of runners 102, 104 are implemented as a pair of skis dimensioned to glide the snow vehicle 100 over a compressed trail covered by the snow and/or the ice 150, and over a cared road covered by the
30 snow and/or the ice 150. The compressed trail may be a snowmobile track or route, for example. The cared road includes pavements and is typically in public use and snow is ploughed as needed. The snow vehicle 100 may not be designed to operate in deep unbroken snow. Depending on the design and use case, the
35 typical maximum snow depth may be 10-20 centimetres, for example.

The pair of skis may be implemented with synthetic material, possibly augmented by suitable metallic structures. In some use cases, the pair of runners 102, 104 may be implemented, alternatively, or additionally, as a pair of flexible metal runners. Note that two (= pair) is the minimum numbers of runners 102, 104, but in some uses cases it is envisaged that additional runners may be added for length and/or stability. In an embodiment, the pair of runners 102, 104 simultaneously combine the pair of skis with a pair of flexible metal runners placed at bottoms of the skis, which results in that the snow vehicle is mainly supported by the pair of skis while travelling over snow, and by the pair of flexible runners while travelling over ice. Each relatively low flexible metal runner may be embedded in the bottom of the ski so that it extends along the longitudinal axis of the ski.

The snow vehicle comprises an electric motor 106 and a traction wheel 108, powered by the electric motor 106, and configured to cause a propulsion for the snow vehicle 100 while rolling in contact with the snow and/or the ice 150.

The electric motor 106 is powered by one or more rechargeable batteries (not illustrated). The one or more rechargeable batteries may be of a similar type as used in e-bikes. The one or more rechargeable batteries may be placed on a suitable place within a frame such as under a seat 114 or behind a backrest 116, for example.

Note that the frame of the snow vehicle may be similar to a metallic frame used in a kicksled (or spark), but also other kind of structures employing also synthetic material may be designed depending on the use case. As shown, the frame comprises two supports 118, 120 for the pair of runners 102, 104. The supports 118, 120 may also be implemented as a single integrated structure, possibly also carrying the one or more batteries. In an embodiment, the one or more supports 118, 120 are provided with one or more shock absorbers, such as with a telescopic suspension employing a spring (implemented with a steel or titanium spring, compressed air, or an elastomer) and a damper.

The electric motor 106 may be a wheel hub motor incorporated into a hub of the traction wheel 108. The wheel hub motor 106 may be of a similar type and configuration as those used in e-bikes. In an embodiment, the wheel hub motor 106 may contain the one or more batteries. The electric motor 106 may be a direct drive system, wherein the motor 106 directly drives the wheel 108, or the electric motor 106 may be a geared system, wherein the motor 106 drives the

wheel 108 via a set of gears.

In an embodiment, the frame of the snow vehicle 100 comprises one or more joints 138 configured so that the snow vehicle 100 is collapsible for storage and transport. Possible directions of folding are illustrated in FIG. 1 with arrows
5 140 and 142.

The traction wheel 108 may be implemented as a pneumatic tyre (with a rim, and either a tubed or tubeless tyre), with a tyre size of 16, 18, 19, 20, 21 or 22 inches, for example. In an embodiment, the traction wheel 108 is of the low pressure -type (possibly designed for low ground pressure such as in an ATV or fat-bike), and/or the traction wheel 108 is of the snow tyre -type, and/or the
10 traction wheel 108 comprises studs. Snow tyres (or winter tyres) usually have a tread design with larger gaps than in traditional (summer) tyres. Some snow tyre have protruding metal or ceramic studs to increase traction on hard-packed snow or ice. In an embodiment, the traction wheel 108 may be similar to that used in an
15 all-terrain vehicle (ATV, also known as quad).

The snow vehicle 100 comprises a seat 114 positioned above the traction wheel 108 and configured to accommodate a person. The seat 114 may also include a backrest 116. Both may be manufactured from wood or synthetic material, for example. The advantage of positioning the seat 114 over the traction
20 wheel 108 is that ground grip is improved if there is a person or goods on the seat 114.

The snow vehicle 100 comprises a steering arrangement comprising a steering axle 122 coupled with the traction wheel 108. The steering axle 122 may comprise structures similar to those of a bicycle comprising a steerer tube
25 mounted within a frame tube and a fork configured to hold the traction wheel 108. In an embodiment, the fork may contain a set of shock absorbers. Additionally, the steering arrangement comprises two steering bars: a handlebar-level steering bar 124 coupled with the steering axle 122 and configured and positioned to enable steering of the traction wheel 108 while a driver is standing
30 on the pair or runners 102, 104, and a seat-level steering bar 128 coupled with the steering axle 122 and configured and positioned to enable steering of the traction wheel 108 while a driver is sitting on the seat 114. As shown in FIG. 3, both steering bars 124, 128 may be similar to those used in a bicycle, wherein the handlebar is coupled to a stem coupled with the steerer tube. The handlebar-level steering bar 124 resembles a drop handlebar having a straight central section
35 attached to the steering axle 122, with each end curving back towards the driver.

The seat-level steering bar 128 resembles an under-seat handlebar of a recumbent.

FIG. 8 illustrates the driver 800 standing on the pair of runners 102, 104 and hanging onto the handlebar-level steering bar 124 to steer the traction wheel 108 via the steering axle 122.

FIG. 9 illustrates the driver 800 sitting on the seat 114 and grabbing the seat-level steering bar 128 to steer the traction wheel 108 via the steering axle 122.

FIG. 10 illustrates the driver 800 standing on the pair of runners 102, 104 and hanging onto the handlebar-level steering bar 124, while a passenger 1000 is sitting on the seat 114. In FIG. 11, the driver 800 sits on the seat 114 and grabs the seat-level steering bar 128, whereas the passenger 1000 is standing on the pair of runners 102, 104. Note that in FIG. 10 and FIG. 11 both the driver 800 and the passenger 1000 may both grab the steering bar 124, 128 and also actually steer. This necessitates some co-ordination and communication, but may also help in a tight spot requiring careful steering.

In an embodiment, the traction wheel 108 is positioned in front of the pair of runners 102, 104. Alternatively, the wheel may be positioned between the front part of the pair of runners (like in a normal type of a kicksled), but the traction and steering effect may be improved by the in front -placing.

In an embodiment, the steering arrangement comprises a first accelerator lever 126 coupled with the handlebar-level steering bar 124 and a second accelerator lever 130 coupled with the seat-level steering bar 128. The steering arrangement comprises a power switch 136 configured to enable the first accelerator lever 126 in a first switch position and the second accelerator lever 130 in a second switch position. The power switch 136 is configured also to have an off position, besides the two on positions (= the first and second switch positions). The power switch 136 may operate with an ignition key or some other access control means to prohibit unauthorized use. The accelerator lever 126, 130 may be implemented as a thumb throttle.

In effect, this means that the driver 800 may choose which accelerator lever 126/130 to use: in the use case of FIG. 10, the driver 800 enables the first accelerator lever 126, whereas in FIG. 11, the driver 800 enables the second accelerator lever 130. In this way, the passenger 1000 cannot accelerate as his/her accelerator lever is not functional.

In an embodiment illustrated in FIG. 3, forward-facing ends of the seat-

level steering bar 128 comprise headlights 132, 134 configured to turn in unison with the steering axle 122. FIG. 3 also illustrates the principle of steering by turning the traction wheel 108, whereby the snow vehicle 100 advances into the direction of arrow 300.

5 FIG. 4 illustrates an embodiment, wherein the snow vehicle 100 comprises a footrest 112 configured and positioned so that it acts as a front ski in contact with an upper surface 500 of the snow 150 while the traction wheel 108 is partly buried deeper in the snow 150. In an additional embodiment, the footrest 112 is coupled by a joint with a frame of the snow vehicle 100 so that the
10 footrest 112 is configured to follow a topography of the upper surface 500 of the snow 150.

 FIG. 5 illustrates an embodiment, wherein the footrest 112 is configured to swivel into a position accommodating goods placed on the seat 114. Furthermore, the backrest 116 may be configured so that it may swivel to cover
15 as a lid the extended compartment formed by the seat 114 and the footrest 112. Alternatively, the footrest 112 may be configured to swivel so that it covers as a lid the compartment formed by the seat 114.

 In an embodiment illustrated in FIG. 6, the snow vehicle 100 comprises at least two tyres 602 couplable with the pair of runners 102. The at
20 least two tyres 602 are configured to, in a drive position, support the snow vehicle 100 travelling over a surface 600 having no snow and/or ice or having the snow and/or the ice covered with gravel. As shown, each tyre may be 602 attachable to the back end of each runner 102, 104. The tyres 602 may be of the solid type used in rollerblades, but they may also be pneumatic. Additional tyres
25 may be placed in front of the runners 102, 104, although as shown in FIG 6, the runners 102, 104 may be lifted off the ground surface 600 even with a pair of tyres 602. The at least two tyres 602 may be removably attachable. Another option is that the at least two tyres 602 are attached to the runners 102, 104 so that that may be positioned between the drive position and a storage position
30 (wherein the at least two tyres 602 do not contact the ground beneath).

 In an embodiment illustrated in FIG. 13, the electric motor 106 comprises a disconnect mechanism 110 to disconnect the electric motor 106 from the traction wheel 108 enabling the traction wheel 108 to freewheel while the snow vehicle 100 is powered by the driver kicking the snow and/or the ice 150
35 by foot. Note that the freewheeling may also take place while riding down a hill to save the one or more batteries. In an embodiment, the electric motor 106 is

configured to implement a braking functionality by hindering or stopping the rolling of the traction wheel 108. Such braking may also be regenerative, i.e., during the braking, the one or more batteries are recharged.

5 In an embodiment, the electric motor 106 is configured to rotate the traction wheel 108 in reverse to back up the snow vehicle 100.

10 In an embodiment illustrated in FIG, 12, the pair of runners 102, 104 is configured to accommodate a toboggan 700 configured to transport one or more persons 1200 and/or goods 1202 while the driver is sitting on the seat 114. As shown, the toboggan 700 may be provided with fastening means 1204 to secure the goods 1202 during the ride. Naturally, the toboggan 700 may be provided with seating arrangements for the passengers 1200.

15 The described embodiments provide a safe and easy to use snow vehicle 100 for everyday use by ordinary people. As such, it may resemble an e-bike, possibly meeting some legislation requirements such as a top speed of 15 km/h, 25 km/h, or some other nationally mandated limit. Also, legal requirements set for the dimensions of a street-legal vehicle may be taken into account in the design. Naturally, as the described snow vehicle 100 defines a new type of vehicle, the legislation is still emerging.

20 Even though the invention has been described with reference to one or more embodiments according to the accompanying drawings, it is clear that the invention is not restricted thereto but can be modified in several ways within the scope of the appended claims. All words and expressions should be interpreted broadly, and they are intended to illustrate, not to restrict, the embodiments. It will be obvious to a person skilled in the art that, as technology advances, the inventive concept can be implemented in various ways.

25

CLAIMS

1. A snow vehicle (100) comprising:
 a pair of runners (102, 104) configured to support the snow vehicle (100) travelling over snow and/or ice (150);
 5 an electric motor (106);
 a traction wheel (108), powered by the electric motor (106), and configured to cause a propulsion for the snow vehicle (100) while rolling in contact with the snow and/or the ice (150); and
 a seat (114) positioned above the traction wheel (108) and configured
 10 to accommodate a person;
characterized in that the snow vehicle (100) comprises a steering arrangement comprising a steering axle (122) coupled with the traction wheel (108), a handlebar-level steering bar (124) coupled with the steering axle (122) and configured and positioned to enable steering of the traction wheel (108)
 15 while a driver is standing on the pair or runners (102, 104), and a seat-level steering bar (128) coupled with the steering axle (122) and configured and positioned to enable steering of the traction wheel (108) while a driver is sitting on the seat (114).
2. The snow vehicle of claim 1, wherein the traction wheel (108) is
 20 positioned in front of the pair of runners (102, 104).
3. The snow vehicle of any preceding claim, wherein the pair of runners (102, 104) comprise a pair of skis dimensioned to glide the snow vehicle (100) over a compressed trail covered by the snow and/or the ice (150), and over a cared road covered by the snow and/or the ice (150).
- 25 4. The snow vehicle of any preceding claim, wherein the steering arrangement comprises a first accelerator lever (126) coupled with the handlebar-level steering bar (124), a second accelerator lever (130) coupled with the seat-level steering bar (128), and a power switch (136) configured to enable the first accelerator lever (126) in a first switch position and the second
 30 accelerator lever (130) in a second switch position.
5. The snow vehicle of any preceding claim, wherein forward-facing ends of the seat-level steering bar (128) comprise headlights (132, 134) configured to turn in unison with the steering axle (122).
6. The snow vehicle of any preceding claim, wherein the snow vehicle
 35 (100) comprises a footrest (112) configured and positioned so that it acts as a

front ski in contact with an upper surface (500) of the snow (150) while the traction wheel (108) is partly buried deeper in the snow (150).

7. The snow vehicle of claim 6, wherein the footrest (112) is coupled by a joint with a frame of the snow vehicle (100) so that the footrest (112) is
5 configured to follow a topography of the upper surface (500) of the snow (150).

8. The snow vehicle of claim 7, wherein the footrest (112) is configured to swivel into a position accommodating goods placed on the seat (114).

9. The snow vehicle of any preceding claim, wherein the snow vehicle
10 (100) comprises at least two tyres (602) couplable with the pair of runners (102, 104) and configured to, in a drive position, support the snow vehicle (100) travelling over a surface (600) having no snow and/or ice or having the snow and/or the ice covered with gravel.

10. The snow vehicle of any preceding claim, wherein the traction
15 wheel (108) is of the low pressure -type, and/or the traction wheel (108) is of the snow tyre -type, and/or the traction wheel (108) comprises studs.

11. The snow vehicle of any preceding claim, wherein the electric
motor (106) comprises a disconnect mechanism (110) to disconnect the electric
motor (106) from the traction wheel (108) enabling the traction wheel (108) to
20 freewheel while the snow vehicle (100) is powered by the driver kicking the snow and/or the ice (150) by foot.

12. The snow vehicle of any preceding claim, wherein the electric
motor (106) is configured to rotate the traction wheel (108) in reverse to back up
the snow vehicle (100).

13. The snow vehicle of any preceding claim, wherein the pair of
25 runners (102) is configured to accommodate a toboggan (700) configured to transport one or more persons (1200) and/or goods (1202) while the driver is sitting on the seat (114).

14. The snow vehicle of any preceding claim, wherein a frame of the
30 snow vehicle (100) comprises one or more joints (138) configured so that the snow vehicle (100) is collapsible for storage and transport.

15. The snow vehicle of any preceding claim, wherein the snow vehicle (100) is of a kicksled type.

PATENTTIVAATIMUKSET

1. Lumiajoneuvo (100) käsittäen:
jalasparin (102, 104), joka on konfiguroitu kantamaan lumiajoneuvoa (100) sen kulkiessa lumella ja/tai jäällä (150);
5 sähkömoottorin (106);
vetorenkaan (108), jolle käyttövoiman antaa sähkömoottori (106), ja joka on konfiguroitu saamaan aikaan käyttövoiman lumiajoneuville (100) pyöriessään kontaktissa lumen ja/tai jään (150) kanssa; ja
istuimen (114), joka on asetettu vetorenkaan (108) yläpuolelle, ja joka
10 on konfiguroitu ottamaan henkilö matkustajaksi;
tunnettu siitä että lumiajoneuvo käsittää ohjausjärjestelyn, joka käsittää ohjausakselin (122), joka on kytketty vetorenkaaseen (108), korkeaan tasoon asetetun ohjaustangon (124), joka on kytketty ohjausakseliin (122), ja joka on konfiguroitu ja asetettu mahdollistamaan vetorenkaan (108) ohjaaminen
15 ajajan seisoessa jalasparilla (102, 104), ja istuimen tasoon asetetun ohjaustangon (128), joka on kytketty ohjausakseliin (122), ja joka on konfiguroitu ja asetettu mahdollistamaan vetorenkaan (122) ohjaaminen ajajan istuessa istuimella (114).
2. Patenttivaatimuksen 1 mukainen lumiajoneuvo, jossa vetorengas (108) on asetettu jalasparin (102, 104) eteen.
- 20 3. Jonkin edellisen patenttivaatimuksen mukainen lumiajoneuvo, jossa jalaspari (102, 104) käsittää parin suksia, jotka on mitoitettu liu'uttamaan lumiajoneuvoa (100) lumen ja/tai jään (150) peittämällä tallautuneella polulla, ja lumen ja/tai jään (150) peittämällä hoidetulla tiellä.
4. Jonkin edellisen patenttivaatimuksen mukainen lumiajoneuvo, jossa
25 ohjausjärjestely käsittää ensimmäisen kaasuvivun (126), joka on kytketty korkeaan tasoon asetettuun ohjaustankoon (124), toisen kaasuvivun (130), joka on kytketty istuimen tasoon asetettuun ohjastankoon (128), ja virtakytkimen (136), joka on konfiguroitu aktivoimaan ensimmäinen kaasuvipu (126) ensimmäisessä kytkinasennossa ja toinen kaasuvipu (130) toisessa
30 kytkinasennossa.
5. Jonkin edellisen patenttivaatimuksen mukainen lumiajoneuvo, jossa istuimen tasoon asetetun ohjaustangon (128) eteenpäin olevat päät käsittävät etuvalot (132, 134), jotka on konfiguroitu kääntymään samaan aikaan ohjausakselin (122) kanssa.
- 35 6. Jonkin edellisen patenttivaatimuksen mukainen lumiajoneuvo, jossa

lumiajoneuvo (100) käsittää jalkatuen (112), joka on konfiguroitu ja asetettu niin, että se toimii etusuksena kontaktissa lumen (150) yläpintaan (500) samaan aikaan kun vetorengas (108) on osittain hautautunut syvemmälle lumeen (150).

5 7. Patenttivaatimuksen 6 mukainen lumiajoneuvo, jossa jalkatuki (112) on kytketty nivelellä lumiajoneuvon (100) runkoon niin, että jalkatuki (112) on konfiguroitu seuramaan lumen (150) yläpinnan (500) pinnanmuodostusta.

10 8. Patenttivaatimuksen 7 mukainen lumiajoneuvo, jossa jalkatuki (112) on konfiguroitu kääntymään asentoon, jossa tavaroita on otettavissa kyytiin istuimelle (114).

15 9. Jonkin edellisen patenttivaatimuksen mukainen lumiajoneuvo, jossa lumiajoneuvo (100) käsittää ainakin kaksi jalaspariin (102, 104) kytkettävissä olevaa rengasta (602), jotka ovat konfiguroituja ajoasennossa kantamaan lumiajoneuvoa (100) sen kulkiessa pinnalla (600), jolla ei ole lunta ja/tai jäätä, tai jolla lumi ja/tai jää on soran peittämää.

10. Jonkin edellisen patenttivaatimuksen mukainen lumiajoneuvo, jossa vetorengas (108) on matalapainetyyppinen, ja/tai vetorengas (108) on talvirengastyypinen, ja/tai vetorengas (108) käsittää nastoja.

20 11. Jonkin edellisen patenttivaatimuksen mukainen lumiajoneuvo, jossa sähkömoottori (106) käsittää irtikytkentämekanismiin (110), jolla kytketään sähkömoottori (106) irti vetorenkaasta (108), joka mahdollistaa vetorenkaan (108) rullata vapaasti samaan aikaan kun ajaja antaa käyttövoimaa lumiajoneuville (100) potkuttelemalla lumella ja/tai jäällä (150).

25 12. Jonkin edellisen patenttivaatimuksen mukainen lumiajoneuvo, jossa sähkömoottori (106) on konfiguroitu pyörittämään vetorengasta (108) pakilla lumiajoneuvon (100) peruuttamiseksi.

30 13. Jonkin edellisen patenttivaatimuksen mukainen lumiajoneuvo, jossa jalaspari (102, 104) on konfiguroitu ottamaan kyytiin kelkan (700), joka on konfiguroitu kuljettamaan yhtä tai useampaa henkilöä (1200) ja/tai tavaraa (1202) ajajan istuessa istuimella (114).

35 14. Jonkin edellisen patenttivaatimuksen mukainen lumiajoneuvo, jossa lumiajoneuvon (100) runko käsittää yhden tai useamman nivelen (138), jotka on konfiguroitu niin, että lumiajoneuvo (100) on kokoontaitettavissa säilytystä ja kuljetusta varten.

15. Jonkin edellisen patenttivaatimuksen mukainen lumiajoneuvo, jossa lumiajoneuvo (150) on potkukelkan tyyppinen.

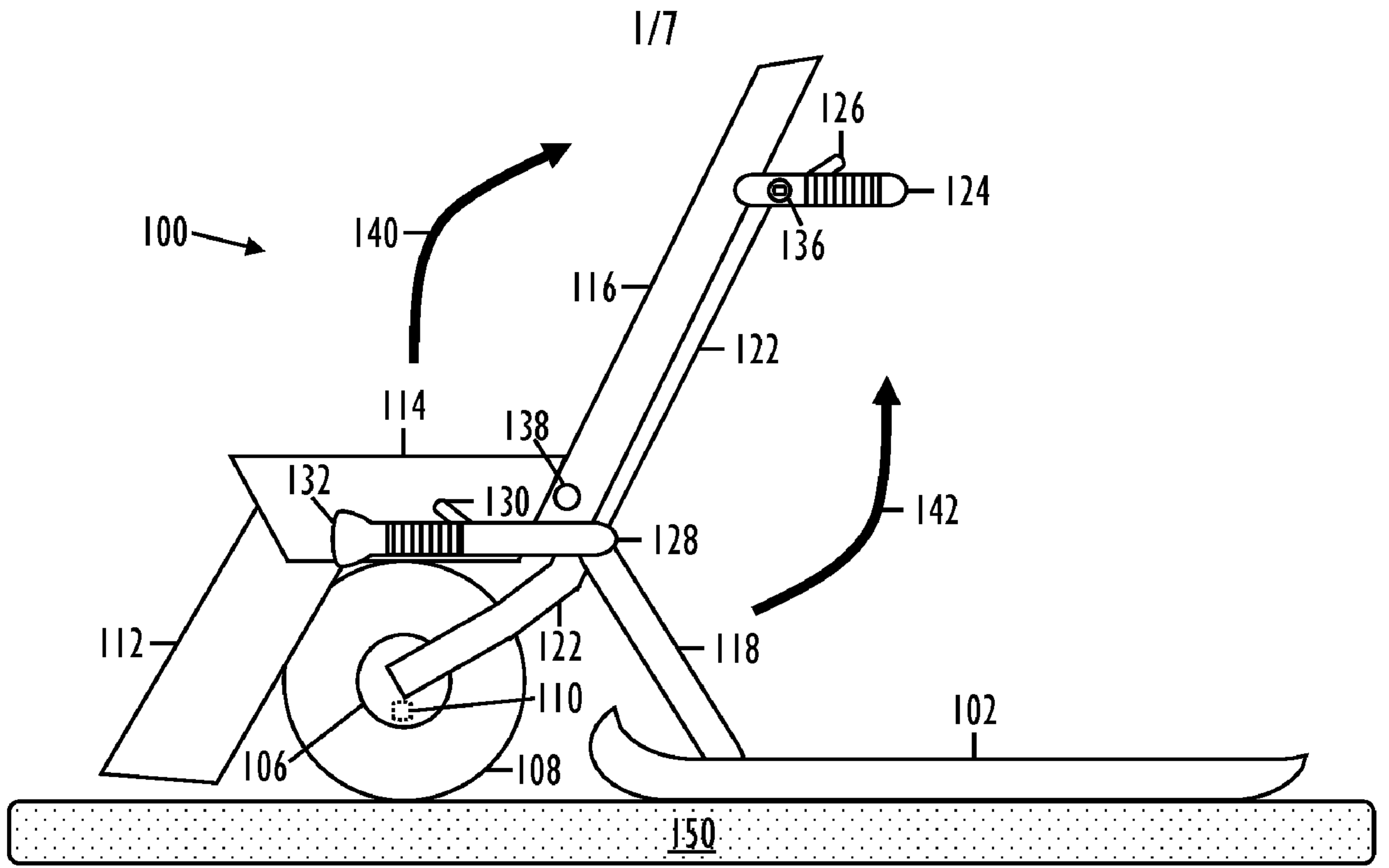

FIG. 1

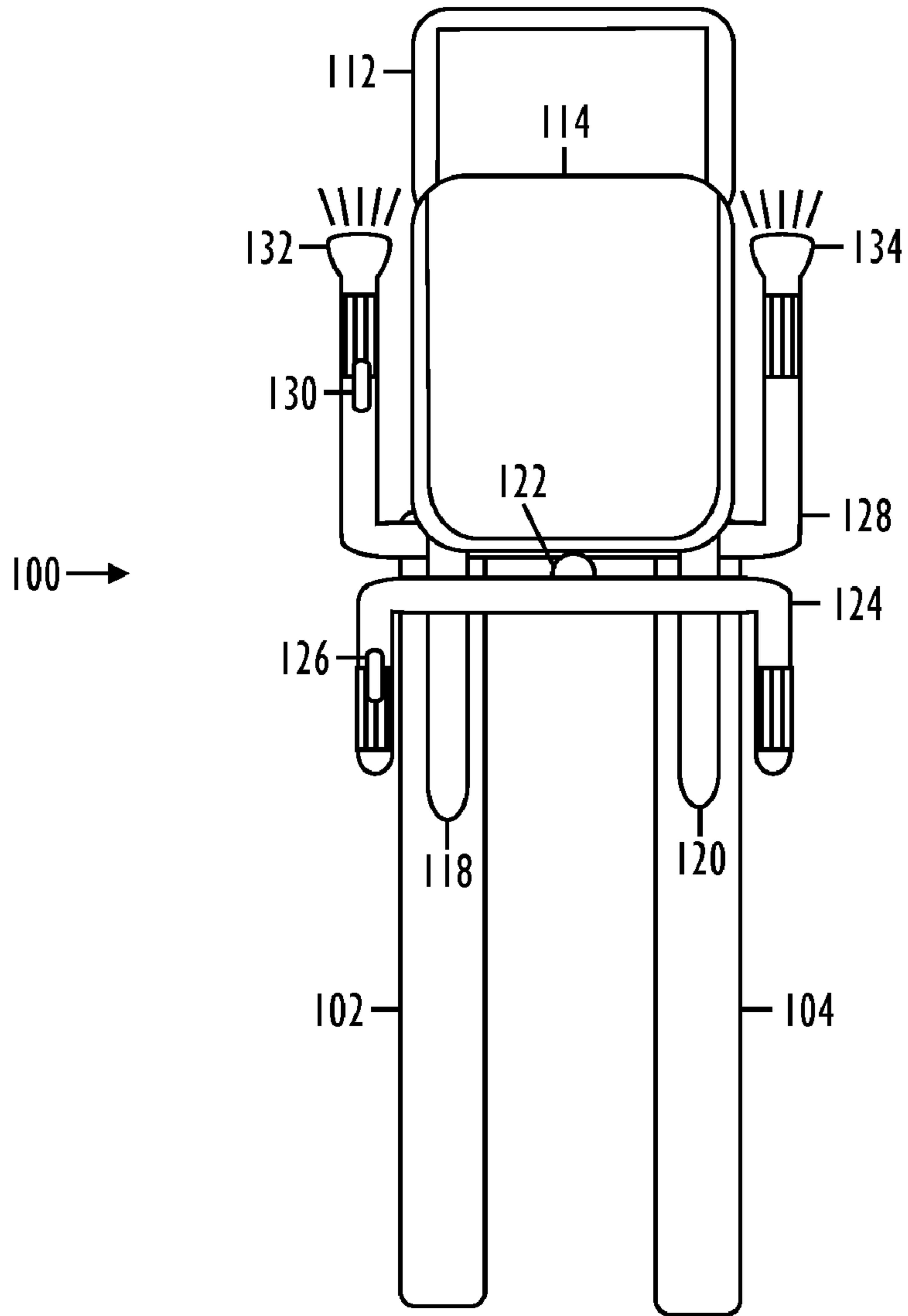

FIG. 2

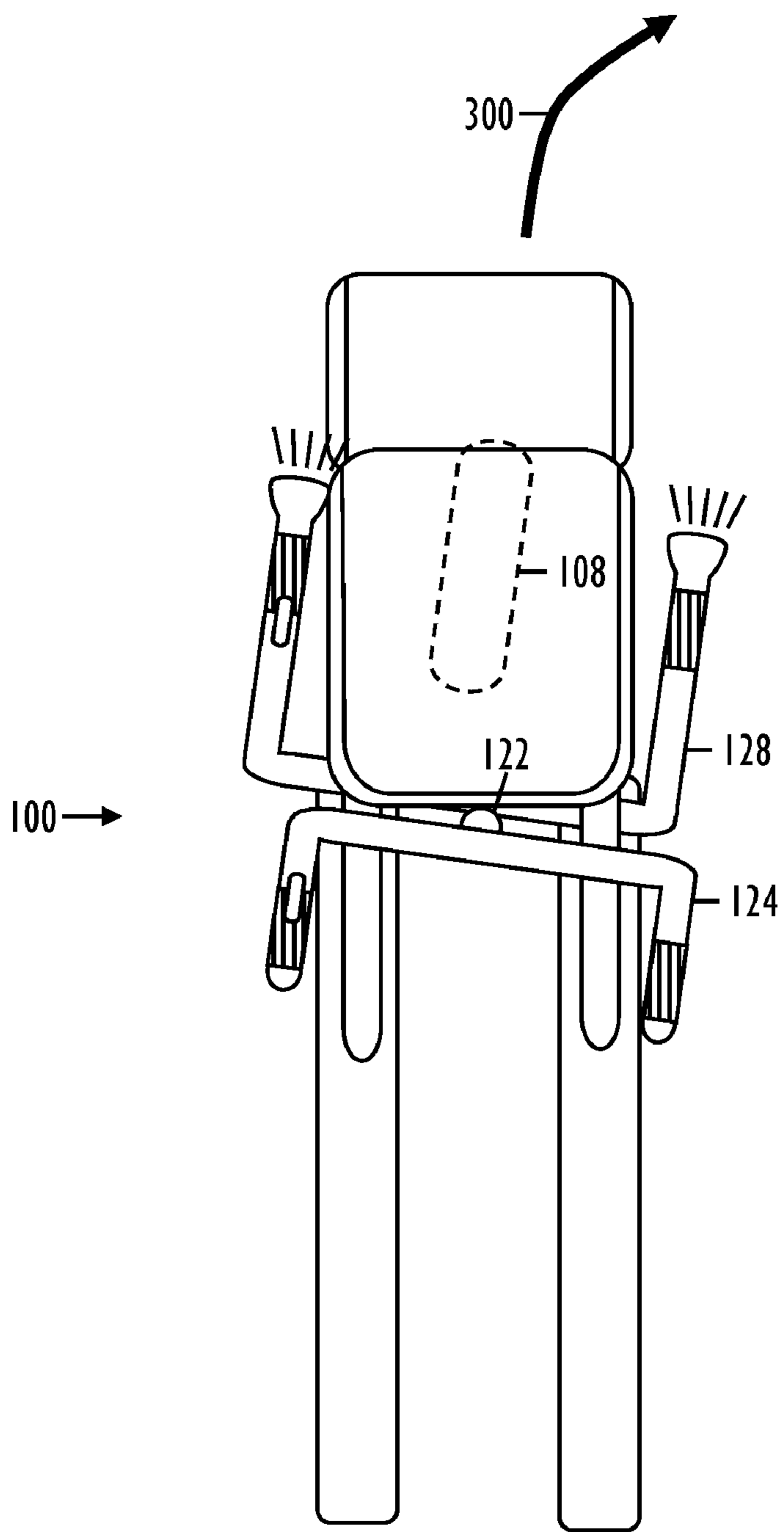

FIG. 3

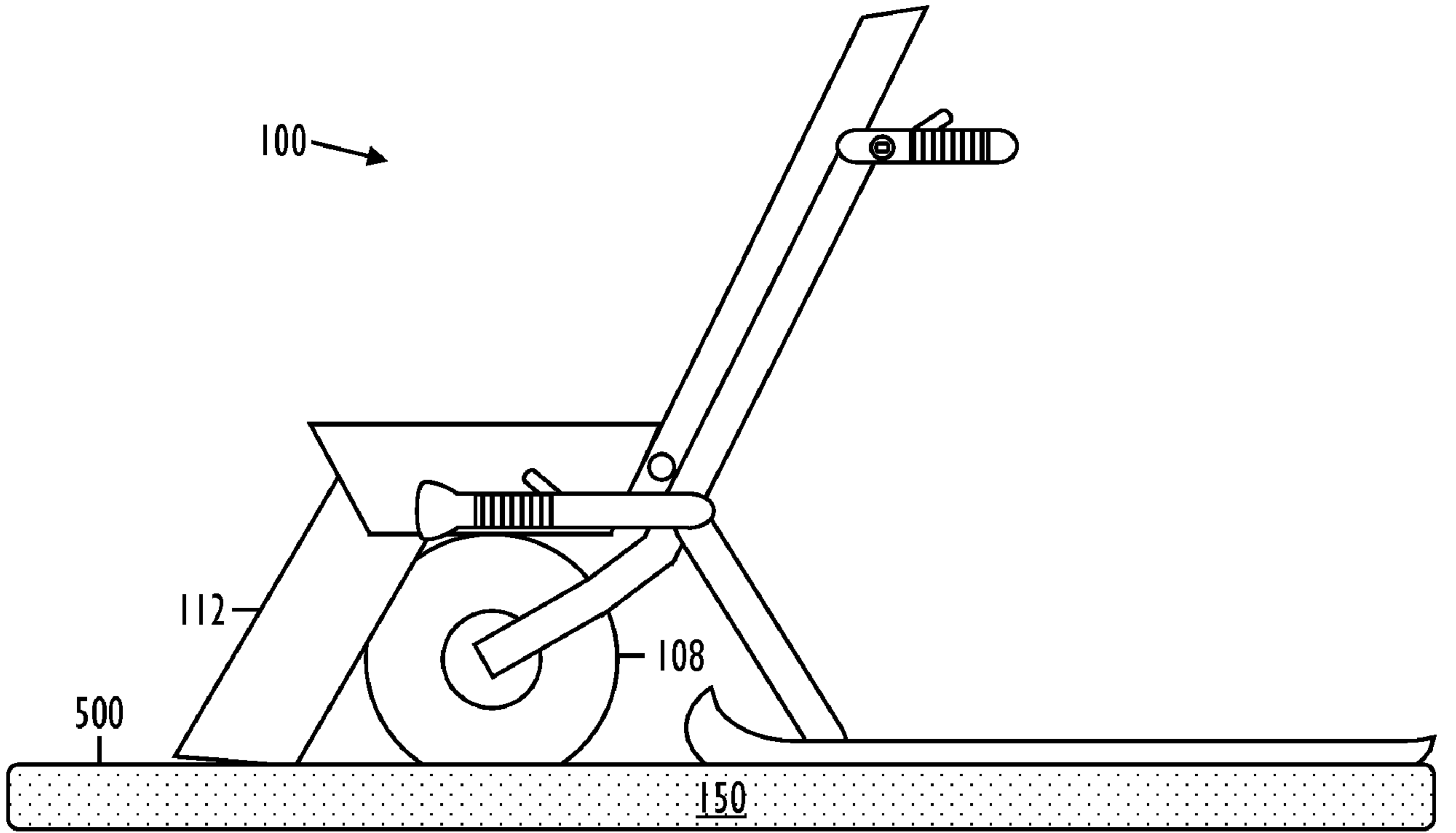

FIG. 4

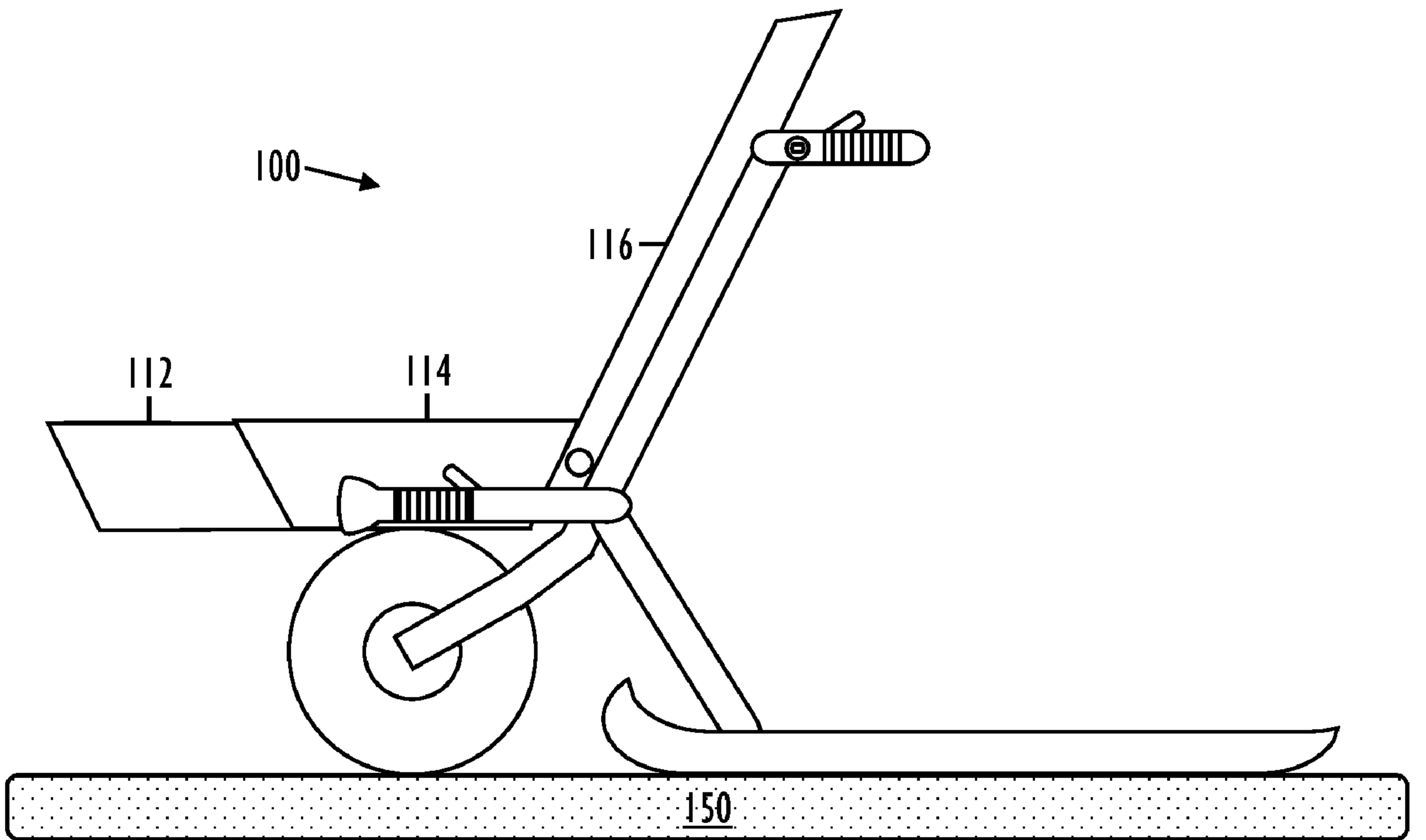

FIG. 5

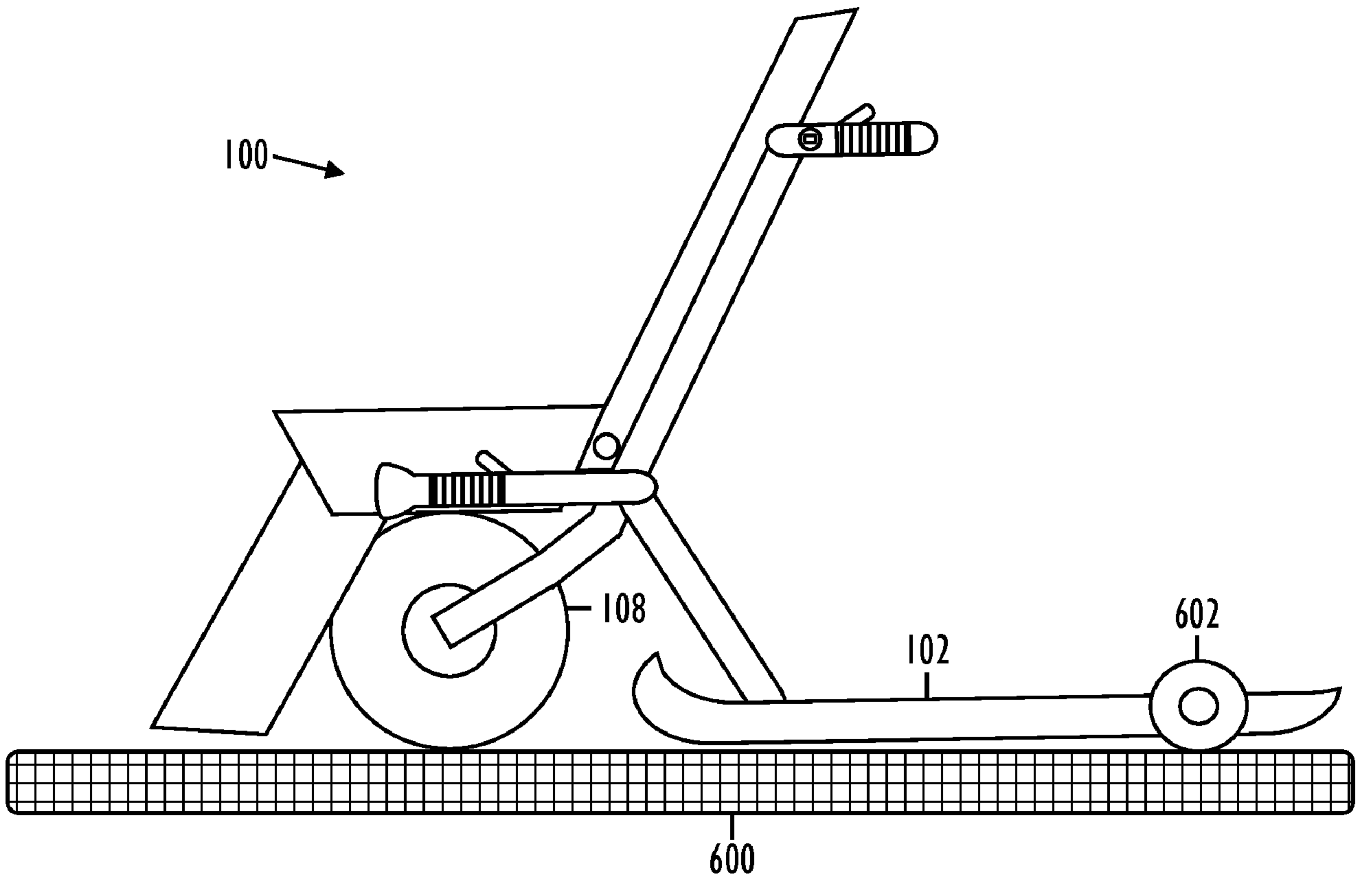

FIG. 6

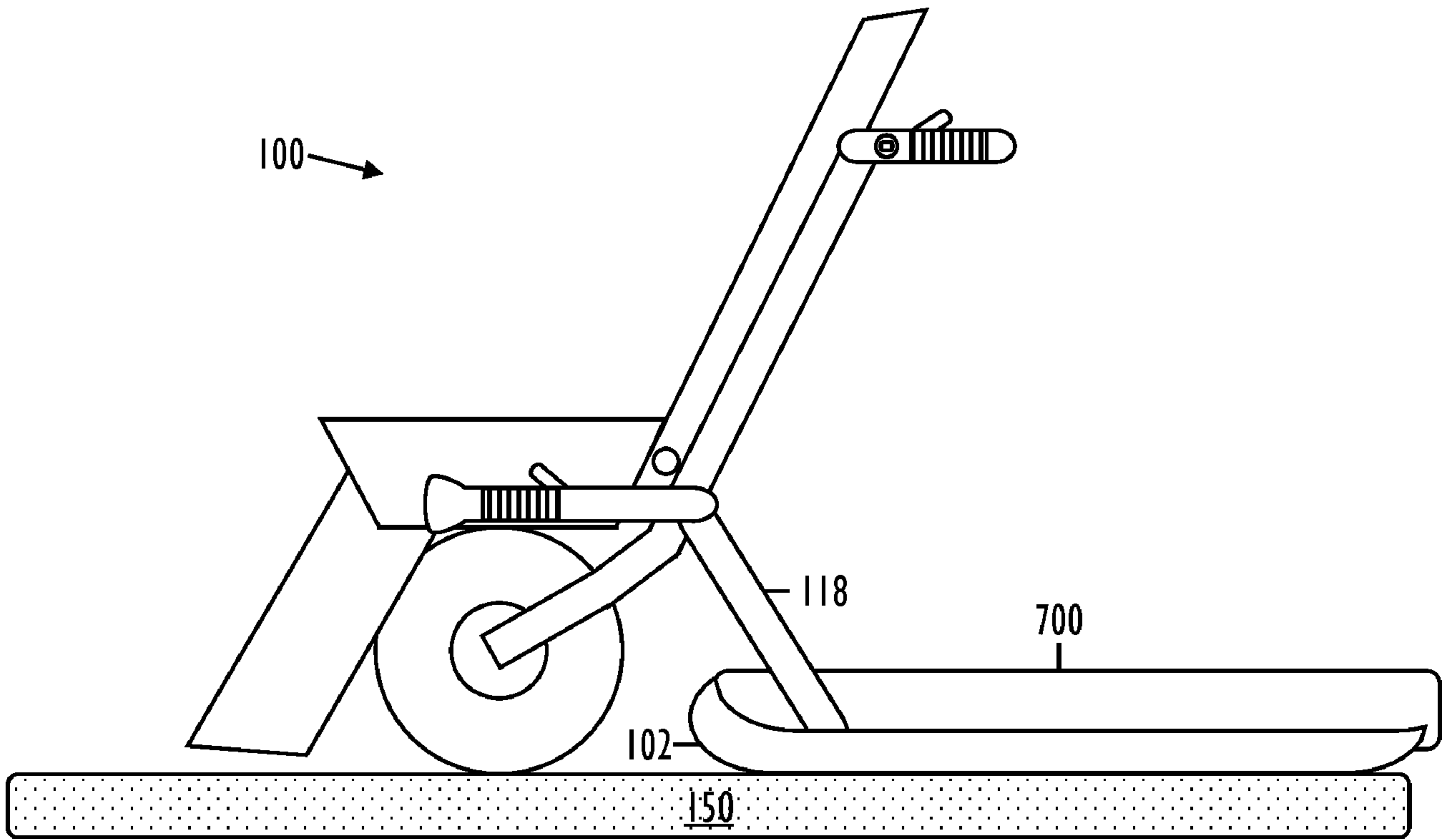

FIG. 7

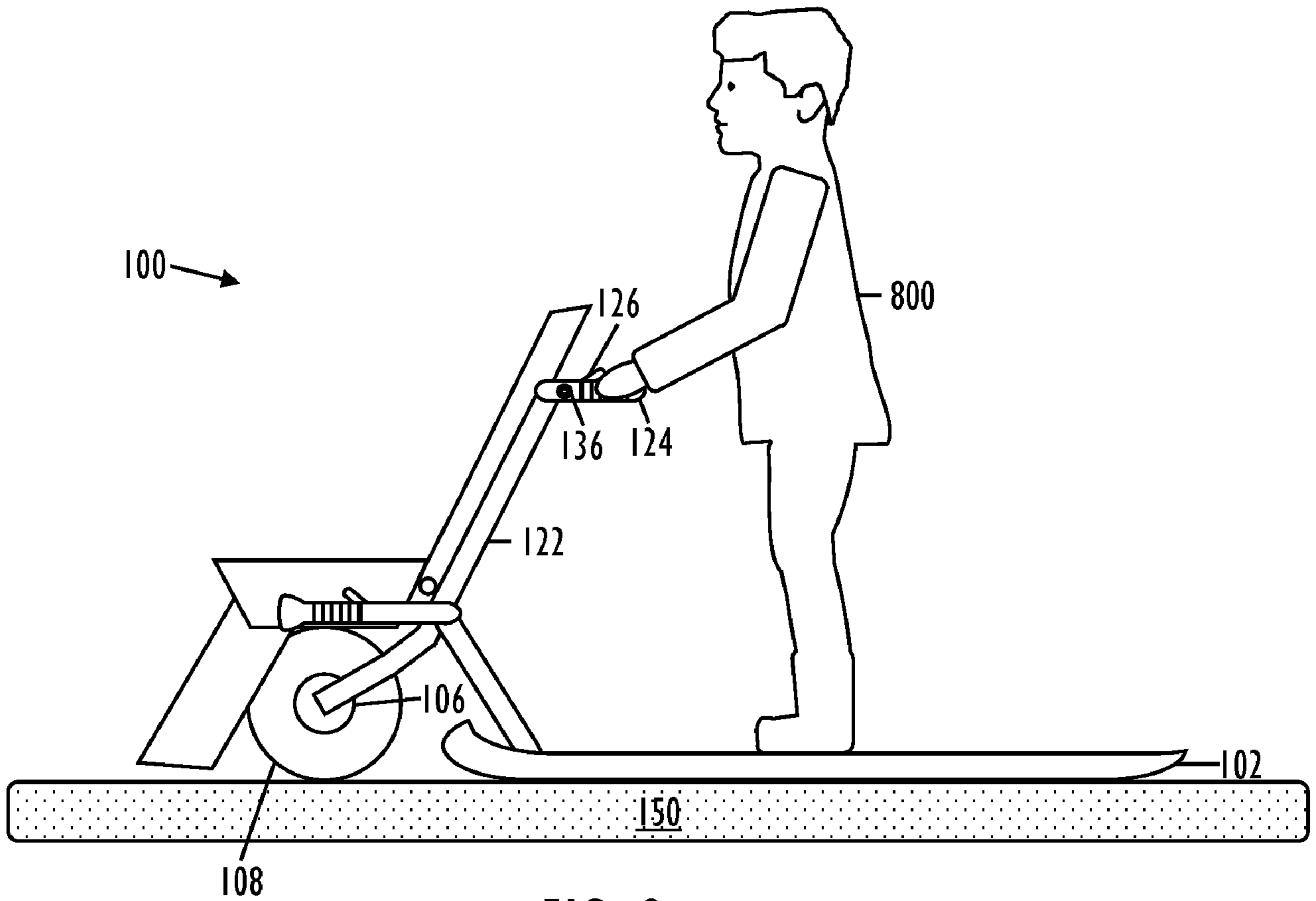

FIG. 8

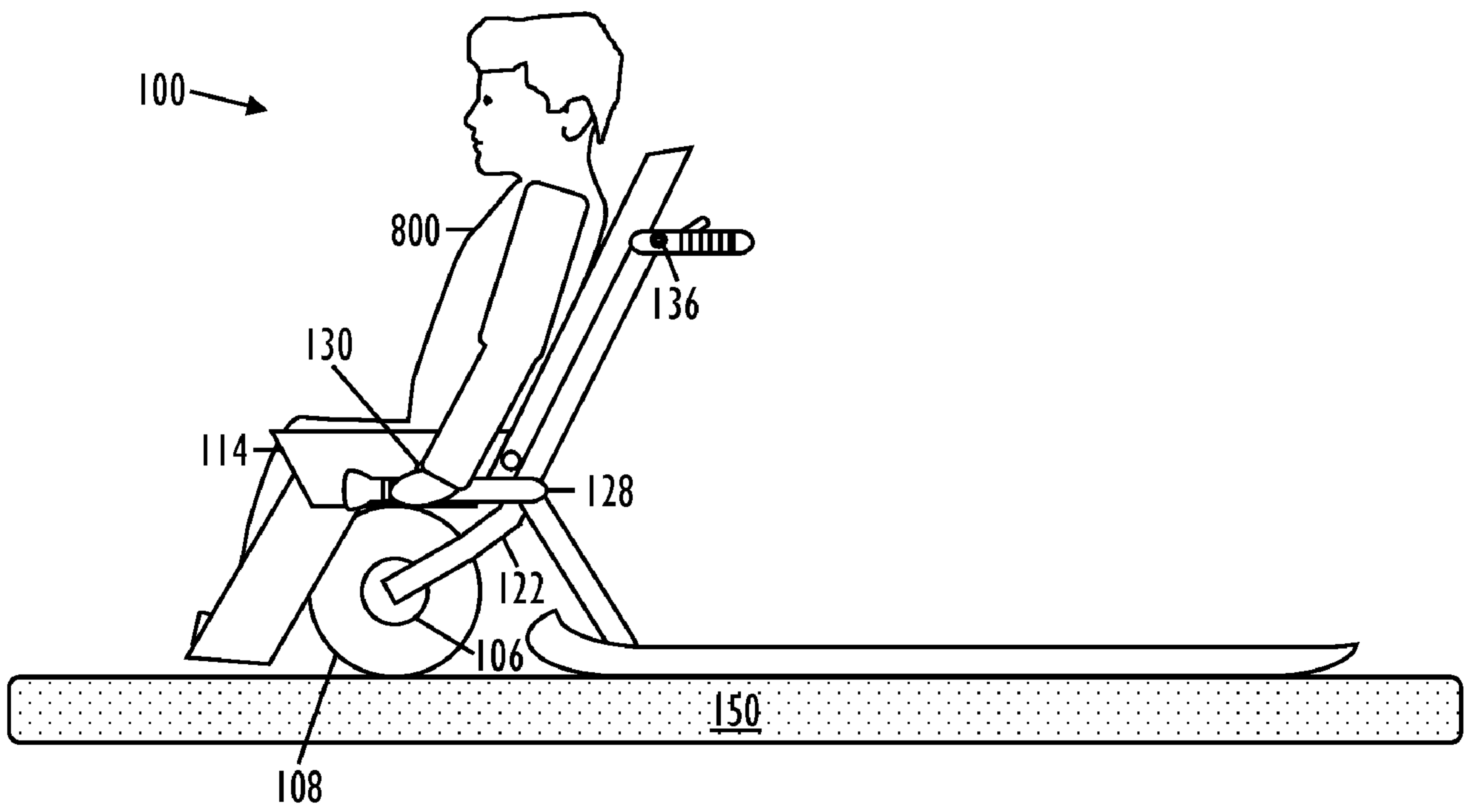

FIG. 9

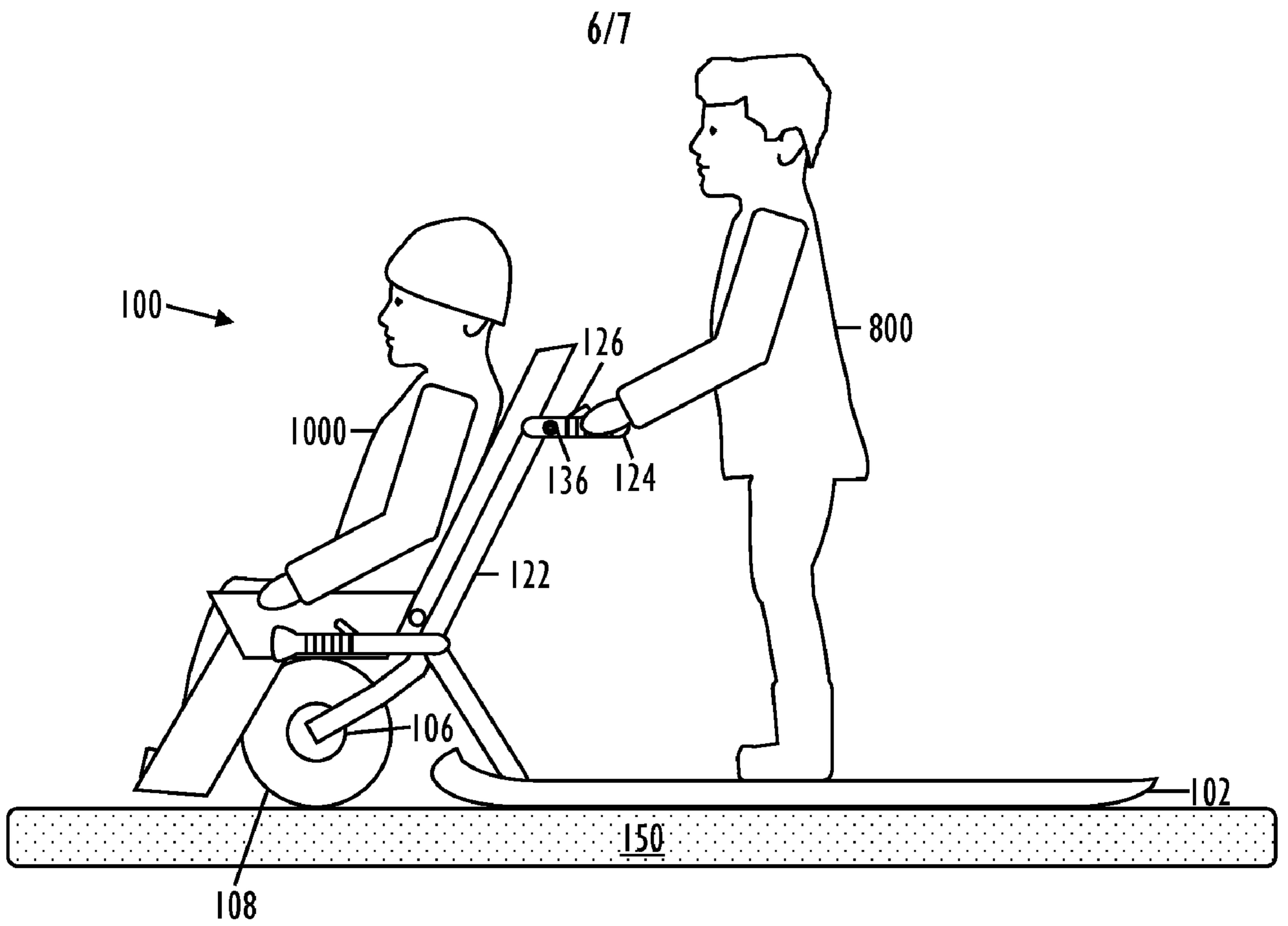

FIG. 10

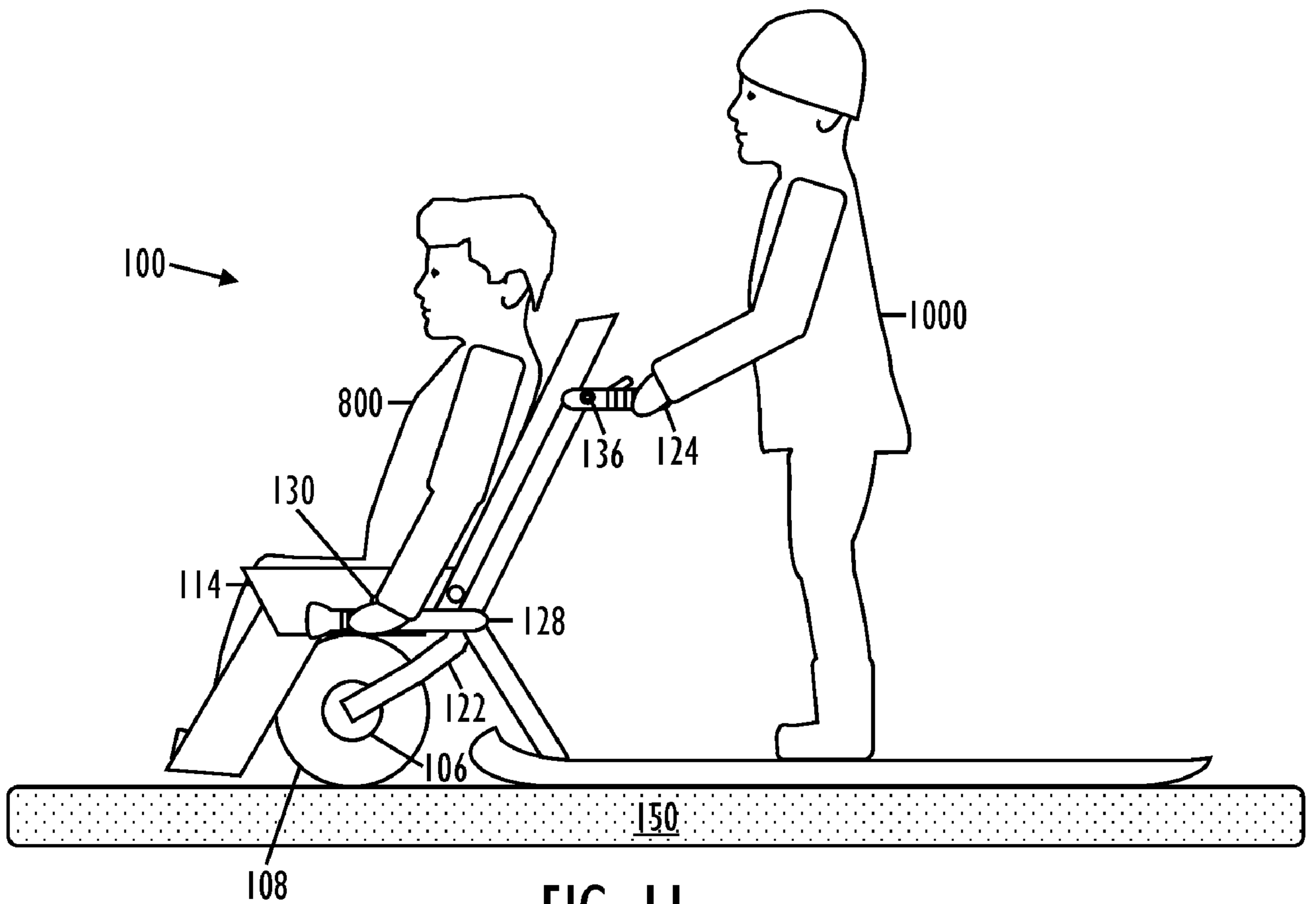

FIG. 11

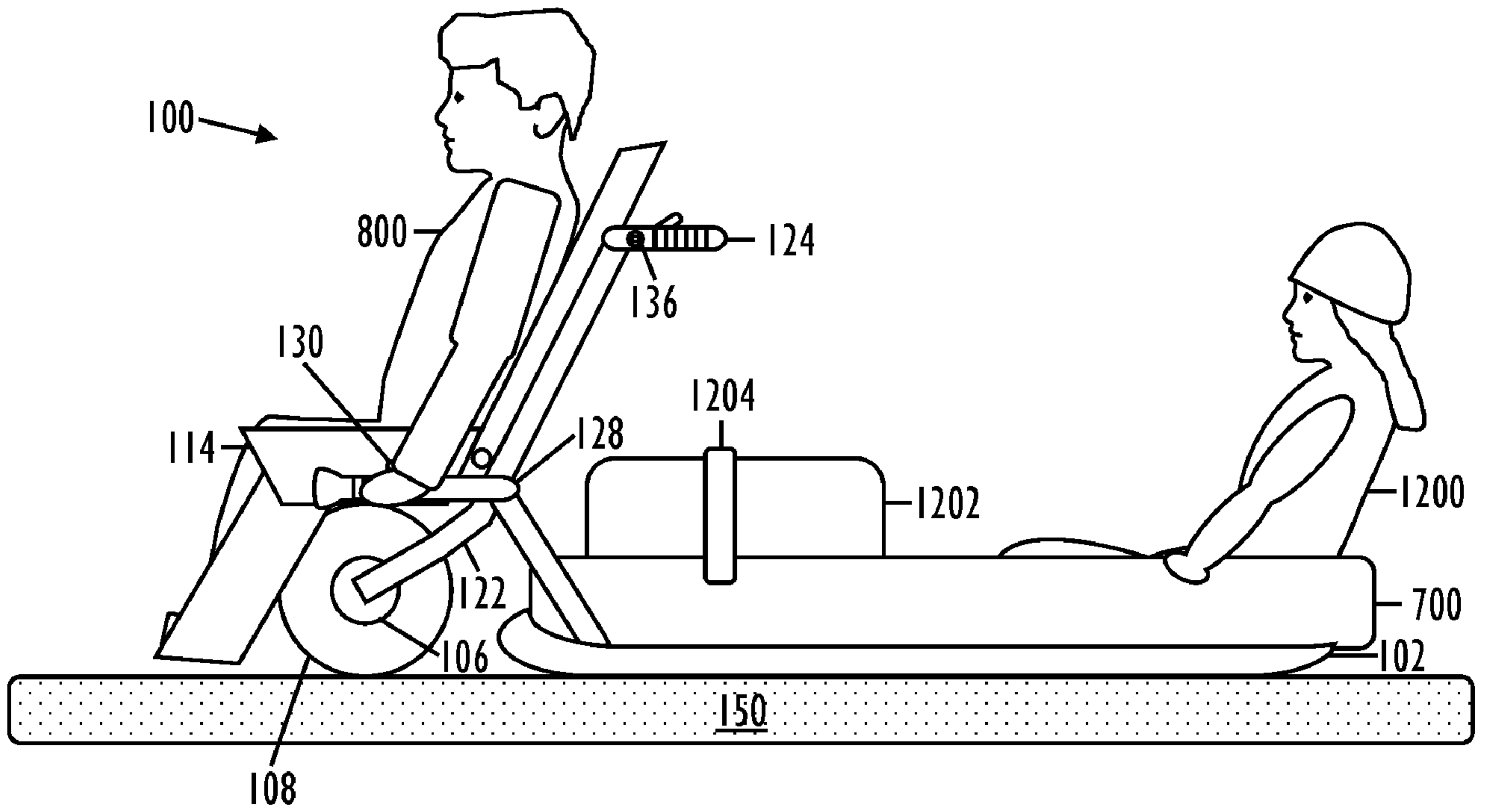

FIG. 12

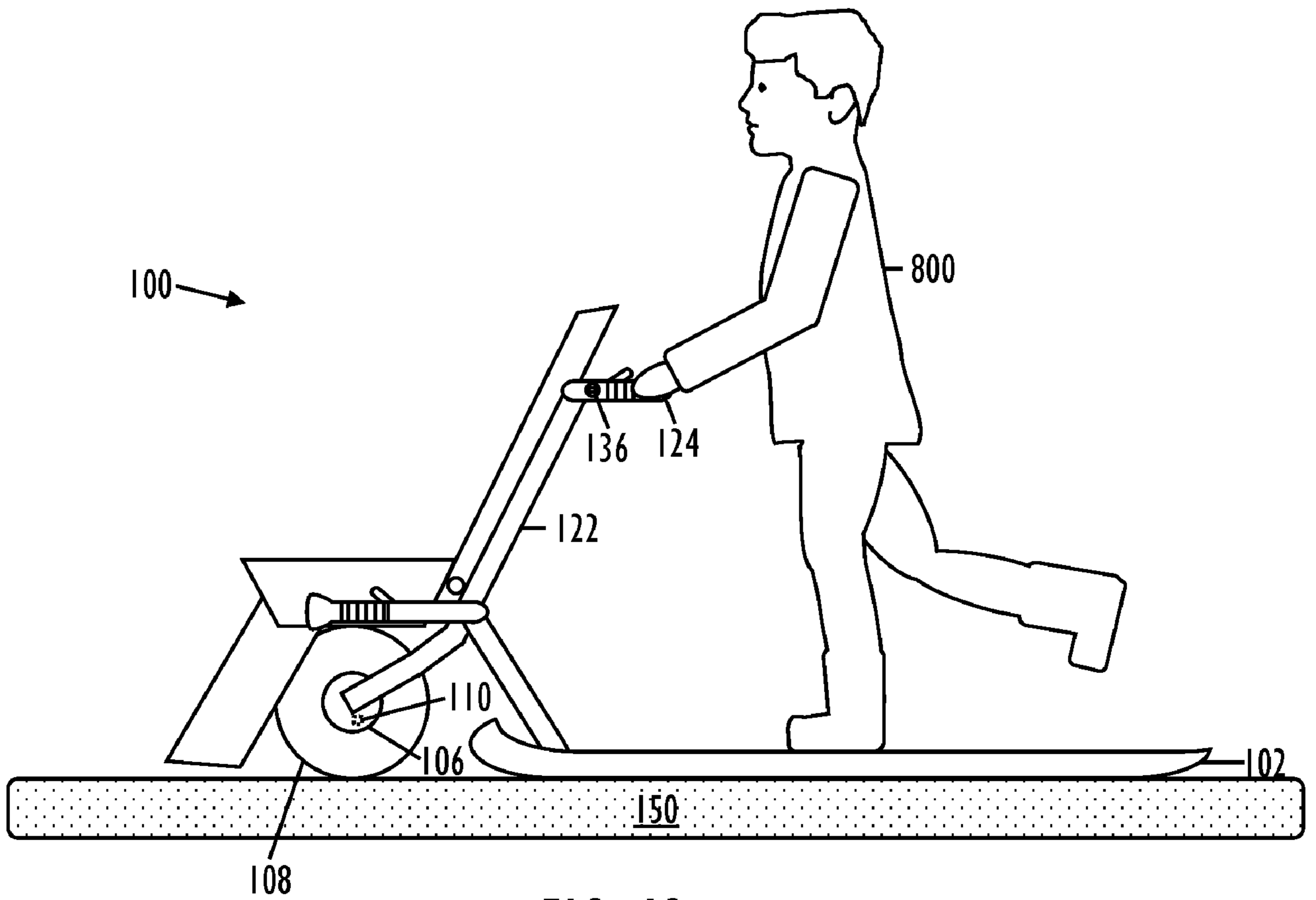

FIG. 13