

F. HOLT.  
 SKULL CUTTER.  
 APPLICATION FILED MAR. 14, 1910.

983,368.

Patented Feb. 7, 1911.

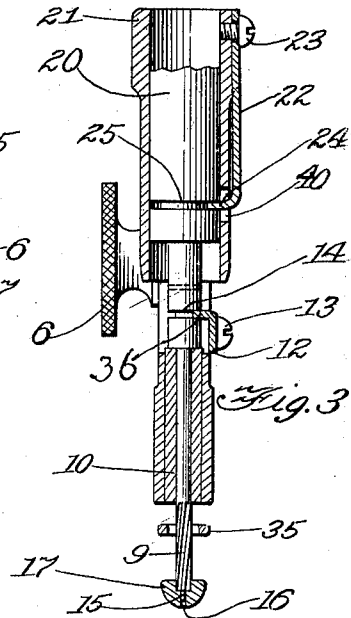
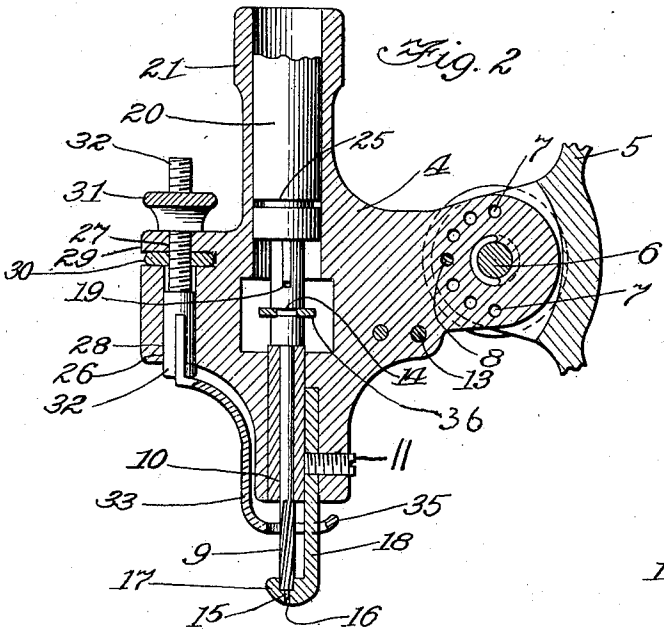
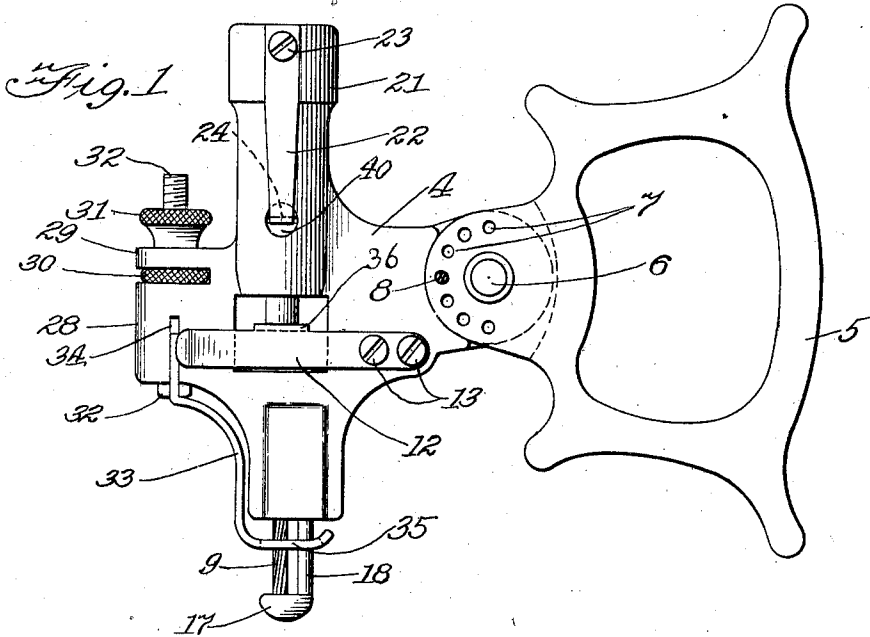

Witnesses:-  
 Wm. H. Yagle  
 J. H. Woodson.

Inventor:-  
 Frank Holt  
 by Carl Prover  
 Atty.

# UNITED STATES PATENT OFFICE.

FRANK HOLT, OF CHICAGO, ILLINOIS.

## SKULL-CUTTER.

983,368.

Specification of Letters Patent.

Patented Feb. 7, 1911.

Application filed March 14, 1910. Serial No. 549,306.

To all whom it may concern:

Be it known that I, FRANK HOLT, a citizen of the United States, residing in the city of Chicago, county of Cook, and State of Illinois, have invented a certain new and useful Improvement in Skull-Cutters, of which the following is a specification.

The object of this invention is to provide a stronger and more convenient tool for the cutting of skulls in surgical operations than has been known before the invention thereof; and to protect the brain and the surrounding dura from injury in skull-cutting operations.

In the drawings Figure 1. is a side elevation of my device; Fig. 2. is a like elevation in section, in a plane coincident with the axis of the cutting tool, and Fig. 3 is a sectional elevation of my device at right angles to that shown in Fig. 2, likewise coincident with the axis of the cutting tool.

Referring to the drawings, 4 represents the frame of my device, 5 a handle, and 6 a thumbscrew by means of which the frame and handle are pivotally joined together.

7 designates a number of holes, all of the same diameter, drilled equi-distant from the axis of thumbscrew 6 into frame 4 and handle 5, respectively; and 8 a pin which is inserted into any two of holes 7, in frame 4 and handle 5, respectively, which are made to register by varying the angle between frame 4 and handle 5. The purpose of these holes 7 and pin 8 is to fix frame 4 and handle 5 more firmly in position, at various angles to each other, than can be done by the mere tightening of thumbscrew 6. A bearing-tube 10 is fastened in the lower end of frame 4 by setscrew 11. Milling tool 9 is held in bearing 10 by spring 12, fastened by screws 13 to frame 4, and engaging, with bent-over edge 36, circular groove 14 in milling tool 9. The foot of this milling tool is provided with axial extension 15 which is mounted in opening 16 drilled through shoe 17 which by means of shank 18 and set-screw 11 is firmly attached to frame 4. The top of tool 9 is provided with slot 19 adapted for engagement to the operating end of a flexible shaft 20; and tube 21, integral with frame 4, surrounds the top of tool 9 for the purpose of holding shaft 20 in proper engagement with slot 19; such engagement being further secured by spring 22, attached to said tube 21 by screw 23, and adapted to engage with

its bent-over edge 24, projecting into the interior of tube 21 through opening 40 therein, circular groove 25 in shaft 20.

In vertical bearings 26 and 27, located in projections 28 and 29, respectively, which extend from the front end of, and are integral with, frame 4, is mounted, and adjustably held, by nut 30 and locknut 31, vertical shaft 32, the upper end of which is threaded for engagement with nut 30 and locknut 31, while into its lower end is fastened, made integral therewith, guard 33 the upper end of which projects sidewise from shaft 32 into vertical slot 34, to prevent turning, while its lower end is formed into a loop 35 which surrounds with ample latitude for slight horizontal motion in any direction, shank 18 and the cutting portion of milling tool 9.

The operation of my device is as follows:—After a sufficient portion of the skull to be operated upon has been laid bare and a preliminary opening made by means of a trephine, shoe 17 is inserted between the edge of the skull and the dura; then guard 33 is adjusted, by means of turning nuts 30 and 31, so that the distance between the upper side of shoe 17 and the lower side of loop 35 slightly exceeds the thickness of the skull. Milling tool 9 is thereupon made to rotate through power transmitted by means of shaft 20, and thereupon is pushed against the edge of the skull with an intermittent motion, along the path desired.

One of the great dangers connected with the use of skull-cutting tools as heretofore constructed, has been the absence of any practical and sufficient means for preventing a slipping of the cutting tool beyond its proper depth. This with my device is absolutely prevented by guard 33 with loop 35, which can readily be adjusted to the thickness of any skull by nut 30 and locknut 31. Another great advantage is the use of handle 5 and its adjustability to different angles by means of the joint between it and frame 4. Previous tools had no such handle and the operator's grasp was not firm enough, and his view constantly obstructed by his hand.

I claim—

1. In skull-cutting tools, the combination of a frame, a rotary cutting tool, means to rotate the tool, a guard to prevent contact of the cutting tool with the dura, and

another guard to prevent slipping of the tool beyond its proper depth.

2. In skull-cutting tools, the combination of a frame, a rotary cutting tool, means to rotate the tool, a guard in which the lower  
5 end of the cutting tool is mounted, and a loop-formed guard surrounding the cutting tool above and adjustable with reference to, the first-named guard.

10 3. In skull-cutting tools, the combination of a rotary cutting tool, means to rotate the tool, and a guard in which the lower

end of the cutting tool is mounted, with a frame carrying at its front end an adjustable guard for limiting the distance to 15 which the tool shall extend below the upper surface of the skull, and at its rear a handle adjustable to different angles with the cutting tool.

FRANK HOLT.

Witnesses:

F. J. BESELER,  
ROBT. A. KROEBER.