

(19)



Europäisches Patentamt

European Patent Office

Office européen des brevets



(11)

**EP 0 683 111 B1**

(12)

**EUROPEAN PATENT SPECIFICATION**

(45) Date of publication and mention  
of the grant of the patent:

**10.06.1998 Bulletin 1998/24**

(21) Application number: **94901038.3**

(22) Date of filing: **03.12.1993**

(51) Int. Cl.<sup>6</sup>: **B65D 81/07**

(86) International application number:  
**PCT/JP93/01767**

(87) International publication number:  
**WO 95/15286 (08.06.1995 Gazette 1995/24)**

(54) **AIR BAG BENDABLE AFTER EXPANDED**

BIEGBARES, AUFBLASBARES KISSEN

COUSSIN GONFLABLE PLIABLE UNE FOIS GONFLE

(84) Designated Contracting States:  
**BE DE DK SE**

(43) Date of publication of application:  
**22.11.1995 Bulletin 1995/47**

(73) Proprietor: **Shinwa Corporation**  
**Kobe-shi, Hyogo 658 (JP)**

(72) Inventor: **MITSUTA, Teruo**  
**Chiba-shi, Chiba 260 (JP)**

(74) Representative:  
**Eder, Thomas, Dr.-Ing. et al**  
**Eder & Schieschke,**  
**Patentanwälte,**  
**Elisabethstrasse 34**  
**80796 München (DE)**

(56) References cited:  
**WO-A-93/04947**                      **JP-A- 3 014 478**  
**JP-A- 4 154 571**                      **JP-A- 4 215 978**  
**JP-U- 4 078 170**                      **JP-U-61 077 374**  
**JP-Y-53 019 876**

**EP 0 683 111 B1**

Note: Within nine months from the publication of the mention of the grant of the European patent, any person may give notice to the European Patent Office of opposition to the European patent granted. Notice of opposition shall be filed in a written reasoned statement. It shall not be deemed to have been filed until the opposition fee has been paid. (Art. 99(1) European Patent Convention).

## Description

### TECHNICAL FIELD

This invention generally relates to an inflatable and foldable air bag. More particularly, the invention relates to an inflatable and foldable air bag which is originally in flattened form, but, when supplied with a quantity of air, inflated to form a plurality of inflatable portions which are divided from one another. The inflatable portions, in their inflated state, may be easily folded into a folded configuration or an hollow, annular configuration (or configuration of closed loop) of a polygonal cross-section. Thus, the air bag according to the invention may be used as a cushioning member or packaging member to fill a free space between articles.

### BACKGROUND ART

When an article having less strength to mechanical shock, such as a videotape recorder or television receiver, is packaged in a packaging container, it is general practice to fill free spaces between the article and the container with cushioning material such as foamed styrene plastic. Such cushioning material is disadvantageous in that it is not well suited to a size of the free spaces or it causes damage of surface finish of the article. In order to avoid the above disadvantages, the applicant has developed various kinds of inflatable air bags including a blowing tube of a self-seal type (for example, the air bag disclosed in Japanese Patent Application No. 02-410577).

Such air bag used as a cushioning member for an article is shown in Fig. 6 at the right-hand side thereof. When the article to be cushioned is a videotape recorder V, for example, three air bags b are applied to one end of the article, as shown in Fig. 6 at the right-hand side thereof. Each air bag b includes a blowing tube a of a self-seal type extending therethrough. The air bags b in flattened form are inserted into the space between the article and the container (not shown). Then, a quantity of air is blown into the air bag for inflation thereof. Unlike prior art cushioning material such as foamed styrene plastic which originally has a fixed volume, the above air bag is convenient as a cushioning material, since it is capable of adjustably fill the free space regardless of the size of the free space.

It is noted, however, that conventional air bag is not capable of being easily folded at its inflatable portion without applying undue force thereto. Accordingly, it is necessary to use three or more air bags in order to cover and cushioning one end of an article, as shown in Fig. 6. Furthermore, the air bags should be inflated separately by blowing air into each air bag. This is cumbersome work. In some cases, additional work is required to connect plural air bags together by means of a length of tape c.

Conventional air bag, when supplied with air, is

inflated to a fixed volume, so that its volume and configuration are not adjustable. Thus, an air bag of a particular size should be prepared depending upon a given article of a different thickness T. This causes inconvenience in terms of production of air bags, since complicated production installation is required.

When there is a free space of a rectangular cross-section in plan between a packaging container and an article to be accommodated therein, such space may be filled to a substantial degree by inserting a single kind of conventional air bags into the free space. On the contrary, and when such free space is of a triangular or quadrangular configuration having varying width or depth, it is impossible for the free space to be sufficiently filled with a single kind of air bags. Thus, two or three kinds of conventional air bags are needed in order to sufficiently fill the free space.

### SUMMARY OF THE INVENTION

The main object of the invention is to provide an inflatable and foldable air bag for cushioning purpose which is capable of being folded even after inflation thereof, which has foldable portions which may be inflated by a single air-blowing operation, which is easily adaptable for articles having a different size and/or configuration, and which may be inflated and folded into an annular form of a desired polygonal configuration.

In accordance with the invention, an inflatable and foldable air bag is provided which includes two sheets of airtight film having a predetermined width, and an air blowing tube of a self-seal type provided between the film sheets. The air blowing tube extends between the sheet films in the longitudinal direction of the sheet films. The opposite edges of one film sheet are sealingly connected to corresponding opposite edges of the other film sheet. A plural pairs of partition lines extend across the width of the film sheets. The film sheets are sealed along the partition lines to form a plurality of inflatable portions between each pair of partition lines. Each inflatable portion includes at least one seal line about which the inflatable portion may be folded. The seal line extends between each pair of partition lines in a manner to permit air flow into entire inflatable portion associated therewith. Thus, each inflatable portion is divided into two or more inflatable sub-portions, whereby it is capable of being folded at the inflatable sub-portions.

Each seal line does not intersect the pair of partition lines so as to leave an air passage between the opposite ends of the seal line and the pair of partition lines. By this, the plural inflatable sub-portions may be completely inflated by a single air-blow operation. The air within each of the inflatable portions may be blown between the inflatable sub-portions. This equalizes degree of inflation among the inflatable sub-portions. When an increased external pressure is applied to a particular one of the inflatable sub-portions, such external pressure may be relieved by permitting air within the

particular inflatable sub-portion flowing into the remaining inflatable sub-portion(s).

Each seal line is explained to be a single continuous line in the above. It is noted, however, that the seal line may be formed as a intermittent line (dotted line). In this case, the air passages at the opposite ends of the seal line may be eliminated.

The seal lines may be easily formed by means of a primitive heat seal apparatus for sealing the opposite edges of the air bag. In this case, the heat seal apparatus is provided with one or more heat seal blades. The heat seal blades are disposed in parallel relative to one another between the opposite edges of the heat seal apparatus in spaced apart relationship for movable in the transverse direction. The heat seal blades are so arranged that the distance (in the transverse direction) between the heat seal blades can be adjustably changed. Thus, the size of each inflatable sub-portion may be easily changed simply by adjusting the distance between the heat seal blades. Accordingly, variation in height (thickness) and/or shape of an article to be packaged may be easily and quickly accommodated.

The number of seal lines, and thus the number of foldable sub-portions may be increased by increasing the number of heat seal blades. When only one seal line is provided in each inflatable portion, the inflatable portion is divided into two inflatable sub-portions. Thus, the air bag may be folded into a L-shaped or V-shaped configuration. When two seal lines are provided in each inflatable portion, the resulting air bag may be folded into three sections. When three and four seal lines are provided in each inflatable portion, the resulting air bag may be folded into four and five sections, respectively. An air bag to be folded into three sections may be used, for example, to packaging and cushioning one end of a quadrangle article. When an article to be packaged is, for example, a glass bottle of a pentagonal configuration or cross-section, an air bag to be folded into five sections may be wrapped around the glass bottle. The air bag may be then inflated by a single air-blow operation. Thus, the air bag is tightly applied on the entire surface of the article, so as to package the article therein and protect it.

At least one of the sealed edges of the air bag may be extended in the transverse direction so as to form a connection tab. The opposite edges may be connected together by means of the connection tab, so as to form an air bag of a closed loop or annular configuration. When the resulting air bag is supplied with a quantity of air from the blowing tube, the inflatable sub-portions of a closed loop or annular configuration are inflated to form an air bag of a hollow, annular configuration. An air bag of a regular polygon or irregular polygon may be easily formed by simply changing the distance between the heat seal blades. It is also possible to form an air bag substantially of a circular configuration by increasing the number of heat seal blades. For example, two seal lines are formed in each inflatable portion, the

resulting air bag may be folded into three sections so as to form an annular configuration of a closed triangle. When three seal lines are provided in each inflatable portion, an annular air bag of a closed quadrangle may be formed. When four seal lines are provided in each inflatable portion, an annular air bag of a pentagonal configuration may be formed. In this manner, annular air bags of a variable polygonal configuration may be prepared. Thus, an air bag of a desired configuration may be inserted into a given free space. The air bag is then inflated by a single air-blow operation so as to appropriately fill the free space in a simple manner. Thus, cushioning and packaging operation may be easily and quickly performed, which could not be expected in prior art.

Accordingly, the present invention provides an inflatable and foldable air bag which easily and securely accommodates variation in shape and size of an article to be packaged, or free space between articles.

#### BRIEF DESCRIPTION OF THE DRAWING

Fig. 1 is a perspective view, in part, of an inflatable and foldable air bag in a flattened form according to one embodiment of the invention;

Fig. 2 is a schematic cross-sectional view along line A-A of Fig. 1 illustrating the air bag in a somewhat inflated form;

Fig. 3 is an enlarged cross-sectional view, in part, of the air blowing tube of Fig. 2;

Fig. 4 is a perspective view illustrating the air bag according to the invention which is inflated and then folded;

Fig. 5 is a schematic sectional view of the air bag of Fig. 4;

Fig. 6 is a schematic elevational view illustrating a cushioning system using prior art air bag (right-hand side) and a cushioning system using the air bag according to the invention (left-hand side);

Fig. 7 is a perspective view, in part, of an annular inflatable air bag according to one embodiment of the invention;

Fig. 8 is a schematic sectional view illustrating the annular inflatable air bag along line A-A in Fig. 7 in somewhat inflated state;

Fig. 9 is an enlarged sectional view illustrating a connection tab and the air blowing tube of the air bag of Fig. 8;

Fig. 10 is a perspective view illustrating a portion of an annular air bag according to the invention inflated to a hollow, triangular configuration; and

Fig. 11 is a schematic plan view illustrating an annular air bag inflated to a triangular configuration (left-hand side) and an annular air bag inflated to a quadrangle configuration (right-hand side) according to the invention.

## BEST MODE FOR CARRYING OUT THE INVENTION

## FIRST EMBODIMENT

A first embodiment of the invention will be explained below with reference to Figs. 1 through 6. The illustrated embodiment is shown as an air bag foldable into three sections according to the invention. It is noted, however, that the air bag is only illustrative but not restrictive. The air bag according to the invention includes, in principle, two sheets of film or front and rear films 1, 2, and a blowing tube 10 of a self-seal type inserted between the films 1 and 2 along one edge of each of the films. The opposite edges of one film are secured to the corresponding opposite edges of the other film by means of heat seal so as to form sealed edges 3 and 4 of the air bag.

Plural pairs of partition lines 5 and 6 are formed by means of heat seal and extend between the opposite sealed edges 3 and 4 of the air bag. By this, a plurality of inflatable portions 7 are successively formed in the longitudinal direction of the air bag, as shown in Fig. 1. An air-free portion is defined between each pair of the adjacent partition lines 5 and 6. The inflatable portions 7, 7 are separated from one another by means of the air-free portions.

The self-seal blowing tube 10 are opened to permit air flow into the individual inflatable portions 7 of the air bag, during air-blow operation. When the air-blow operation has been completed, the blowing tube 10 is pressingly closed in self-seal manner by means of the air pressure within the inflatable portions, so as to prevent out-flow of air from the inflatable portions. While various kinds of blowing tubes have been developed by the assignee of this application, a blow tube having a plurality of parallel passages, as disclosed in the above Japanese Patent Application No. 02-410577, is shown in the drawing.

Each inflatable portion 7 is provided with two folding seals 8-1 and 8-2 extending in parallel with the opposite edges of the air bag. The folding seals 8-1, 8-2 are disposed between the partition lines 5 and 6 in a manner that they do not intersect the partition lines 5 and 6. Thus, each inflatable portion 7 is divided into three inflatable sub-portions 7-1, 7-2 and 7-3. Although not shown in the drawing, each inflatable portion 7 may be provided with more than two folding seals. For example, three or four folding seals may be provided in each inflatable portion, so as to divide the inflatable portion into four or five inflatable sub-portions. The folding seal 8-1 and 8-2 may be formed using a primitive heat seal mounted with a heat seal blade adjustably movable in a direction transverse to the longitudinal direction of the air bag, i.e., in the transverse direction, as mentioned above. Thus, the position of the folding seals 8 may be easily changed by adjusting the position of the heat seal blade, as desired. Accordingly, the size or dimension of each of the inflatable sub-portions may be easily altered

or modified.

Gaps of an appropriate distance are formed between the opposite ends of the folding seal 8 (as a representative of 8-1, 8-2) and the transverse partition lines 5 and 6. The gaps constitute air passages 9 between the inflatable sub-portions. Operation of the air passages 9 will be explained later with reference to Fig. 5.

Fig. 2 is a schematic, cross-sectional view along line A-A of Fig. 1. The air bag in Fig. 2 is shown in somewhat inflated state for convenience of illustration, though the air bag in reality is in a flattened state prior to air-blowing. The self-seal blowing tube 10 is sealingly attached, at its one edge, to the sealed edge 3. The opposite edge of the blowing tube 10 is configured so as to permit air-blow into the individual inflatable portions 7. Fig. 3 is a cross-sectional view of the sealed edge 3 of Fig. 2. In this Figure, the sealed edge 3 is enlarged so as to clearly illustrate the blowing tube 10. The upper film 1 and the lower film 2, together with the blowing tube 10, are shown in somewhat inflated state.

The illustrated blowing tube 10 includes a blowing passage 11 disposed at one side of the blowing tube 10 close to the sealed edge 3 and extending through the bag in the longitudinal direction. Intermittent seals 12 are formed at the other side of the blowing tube 10. In each inflatable portion 7, at least one self-seal opening (non-sealed portion) 13 is formed between the intermittent seals 12 and 12. Second intermittent seals 14 are formed and spaced from the intermittent seals 12. A self-seal opening 15 is defined between the adjacent intermittent seals 14 and 14. Third intermittent seals 16 are formed and spaced from the intermittent seals 14. A self-seal opening 17 is defined between the adjacent intermittent seals 16 and 16. Fourth intermittent seals 18 are formed. A self-seal opening 19 in communication with the inside of the inflatable portion 7 is defined between the adjacent the fourth intermittent seals 18 and 18.

As shown in Fig. 1, it is preferable for the self-seal openings 13, 15, 17 and 19 to be arranged in a staggered fashion, so as to assure self-seal operation thereof. A partition passage 20 (or a blind passage) is defined between the intermittent seals 12 and 14, as shown in Fig. 3. Similarly, a partition passages 21 and 22 are defined between the intermittent seals 14 and 16 and intermittent seals 16 and 18, respectively. The blowing passage 11 extends through all inflatable portions 7 and is opened to at least one end of the air bag. On the contrary, the partition passages (blind passages) 20, 21 and 22 are all partitioned by each inflatable portion 7 and is not in communication with the adjacent inflatable portions.

This is accomplished, for example, by clamping an original form of a blowing tube 10 formed with the intermittent seals 12, 14, 16 and 18 between a front film 1 and a rear film 2. Then, the transverse partition lines 5 and 6 are formed in the films 1 and 2 by means of heat

seal. At this time, non-heat weldable paint, printing ink or lacquer is preliminarily applied to only the inside of a tube corresponding to the blowing tube 11.

The inflatable and foldable air bag according to the invention presents a configuration of a flat sheet prior to air blowing, as shown in Fig. 1. The blowing tube 10 is also flattened. When a quantity of air is blown into the open end of the blowing passage 11 by means of an air compressor, for example, the air causes the self-seal opening 13, 15, 17 and 19 of each of the inflatable portions 7 to be successively opened. The air flows into each inflatable portion 7 (inflatable sub-portion 7-1 in the illustrated embodiment) so as to cause the inflatable portion 7 to be inflated. In spite of presence of the folding seals 8, the air is sequentially flown into the inflatable sub-portions 7-2, 7-3 so as to cause them to be inflated, due to that fact that each folding seal 8 has passages 9 at the opposite ends thereof. When the inflatable portions 7 are inflated to a desired degree, the blowing operation is stopped. By this, the blowing tube 10 is compressed by the air pressure P within the inflatable portions. Thus, all of the self-seal openings 19, 17, 15 and 13, the partition passages 22, 21 and 20, and the blowing passage 11 are collapsed into a flattened configuration to be closed, as will be explained below with reference to Fig. 5. Accordingly, the inflatable portions 7 are maintained at their inflated state so as to serve as a cushioning material or a packaging material.

As will be appreciated from the foregoing, the air bag according to the invention, even after inflated, may be freely folded at the folding seals 8 (8-1, 8-n). On the contrary, in the prior art air bag shown in Fig. 6 at the right-hand side thereof, the inflatable portions cannot be easily folded even when they have a substantial length. In some cases, such air bag may be torn. Such risk may be avoided in accordance with the invention. An air bag folded into a substantially C-shaped configuration after inflation is shown in Fig. 4. At this time, the blowing tube 10 has been collapsed into a flattened form so as to serve as a self-seal valve. Fig. 5 shows the air bag of Fig. 4 in a schematic cross-section. In Fig. 5, the blowing tube 10 has been collapsed, by means of the air pressure P within the inflatable sub-portions 7-1, into a flattened form of almost a single sheet of film.

Although the folding seals 8-1, 8-2, ... are shown as a single continuous line, it is possible for the folding seals to be formed as a intermittent line (broken line), as mentioned above. In such a case, the gaps (discontinuities) of the intermittent lines serve as a air-flow passage between the inflatable sub-portions, so that it is unnecessary to leave the passages 9 at opposite ends of the folding seal 8.

One advantageous feature of the air bag according to the invention is that, when it is folded and thus, for example, any one of the inflatable sub-portions is subjected to particularly high external pressure, it is possible for air to be flown through the passages 9 at opposite ends of the folding seal 8, or, through the dis-

continuities of the folding seal in a form of an Intermittent line, as shown by arrow mark F in Fig. 5. Accordingly, when any one of the inflated, inflatable portions is subjected to an extraordinarily high external pressure, a portion of the air within a particular inflatable sub-portion may be flown into remaining inflatable sub-portions. By this, the external pressure may be relieved, so as to avoid the air bag from bursting.

A inflatable and foldable air bag according to the invention is shown in Fig. 6 at the left-hand side thereof. The air bag is used to package an article at one end thereof in cushioning manner. As will be clear when compared with the conventional air bag shown in Fig. 6 at the right-hand side thereof, only one air blowing passage 10 is required for the air bag of the invention in order to enclose one end of the article at its three surface in C-shaped configuration. Thus, only a single operation of air blowing is required. Since the inflatable sub-portions 7-1, 7-1 and 7-3 are originally connected in series one another, no additional connection tape such as c is not needed. When it is intended to apply the air bag of the invention to an article having a different thickness T, the distance between the adjustable heat seal blades may be changed so as to suitably change the position of the folding seals 8. By this, inflatable sub-portions 7-2 of a required length may be formed. Accordingly, it is not necessary to change the entire design of the air bag. This is advantageous in terms of economy.

## SECOND EMBODIMENT

Second embodiment according to the invention will be explained below with reference to Figs. 7 through 11. In the drawings, an annular inflatable air bag of a closed triangular configuration is shown as an example. It is noted, however, that this invention may be equally applied to an air bag of a quadrangular shape, pentagonal shape, or, polygonal shape close to a circular configuration. Thus, the illustrated embodiment is not restrictive. The illustrated air bag has a basic construction similar to that of the first embodiment.

That is to say, reference numerals 31 and 32 designate films similar to the films 1 and 2 of the first embodiment, reference numerals 33 and 34 sealed edges of the air bag, reference numerals 35 and 36 partition lines, reference numeral 37 (37-1, 37-2, 37-3) inflatable portion(s), reference numeral 38 (38-1, 38-2) folding seal(s), reference numeral 39 an air passage, reference numeral 40 a connection tab, reference numeral 41 a blowing tube of a self-seal type, reference numeral 42 a blowing passage, reference numeral 42a an opening of the blowing passage 42, reference numerals 43, 45, 47 and 49 intermittent seals, reference numerals 44, 46, 48 and 50 self-seal openings, and reference numerals 51, 52 and 53 partition passages.

The air bag according to the second embodiment is featured by the construction in which the sealed edge

33 is extended laterally and in which the connection tab 40 is provided. The opposed sealed edges 33 and 34 are bonded with the connection tab 40 by means of adhesion, welding or mechanical means. As will be easily appreciated from Figs. 7 and 8, the air bag is of a substantially annular configuration.

The folding seal 38 includes two folding seals 38-1 and 38-2. Thus, each inflatable portion 37 is divided into three inflatable sub-portions 37-1, 37-2 and 37-3. The air bag, when inflated, represents annular configuration of a substantially triangular shape, as shown in Fig. 10 which will be explained later. When three folding seals are provided as mentioned above, an annular air bag of a closed quadrangular shape consisting of four inflatable sub-portions is formed (see Fig. 11). When four folding seals are provided, an annular air bag of a closed pentagonal shape consisting of five inflatable sub-portions is formed. The folding seals 38-1 and 38-2 may be formed by providing a primitive heat seal device with adjustable heat seal blade(s) movable in the transverse direction, as mentioned above. Thus, the position of the folding seal 38 may be easily changed, as desired, by adjustably changing the position of the heat seal blade(s). Accordingly, configuration of an annular air bag may be easily changed, for example, from an equilateral triangle to a scalene triangle. The thus constructed air bag may be inflated to have a hollow triangular prism consisting of inflatable sub-portions 37-1, 37-2 and 37-3 connected in an annular form, as shown in Fig. 10. Such air bag has a substantial strength to withstand a considerable pressure or load either in the horizontal or vertical direction.

The air bag according to the invention inflated in an annular form as shown in Fig. 10 may be used, for example, to fill a triangular space b in a container B shown in Fig. 11. To this end, an annular, flattened air bag (no air is blown therein) is originally inserted into the space b. Then, air is blown through an open end 42a of the blowing tube 41 (Fig. 7) by means of an air compressor. By this, air is supplied from the blowing passage 42 through the self-seal opening 44. Consequently, all the remaining self-seal opening 46, 48 and 50 are opened to cause the inflatable sub-portions 37-1, 37-2 and 38-3 to be inflated while maintaining the annular form of the air bag. Air-blow operation is stopped when the air bag has inflated to occupy the full volume of the space b. Then, the inflation tube 41 is collapsed into a flattened form by means of air pressure within the inflatable portion so as to exert its self-seal function, whereby each inflatable portion is maintained in its inflated position. As will be appreciated from the foregoing, the inflatable annular air bag according to the invention may be prepared to have an annular or looped configuration suitable for a particular space of a triangular, quadrangular or other shape. The air bag in the flattened form is inserted into the objective space and then inflated by means of a single air-blow operation. By this, the air bag is inflated to occupy the full volume of the

space to appropriately fill the space.

When the objective space is of a quadrangular configuration, for example, an annular air bag of a quadrangular shape consisting of four inflatable sub-portions 37-1, 37-2, 37-3 and 37-4 may be formed. The inflatable sub-portions may be folded at folding seals 38-1, 38-2 and 38-3, as shown in Fig. 11 at the right-hand side thereof. The air bag in the flattened form is inserted into the quadrangular space. Then a quantity of air is blown into the air bag. By this, the air bag is inflated to have a hollow annular column of a quadrangular shape, so as to fill the space c in an appropriate manner. The air bag inflated into an annular form serves not only to exert transverse or horizontal expansion force within the space b or c to fill the space, but also to exert expansion force to withstand a vertical load (a load acting in the direction perpendicular to the sheet of Fig. 11).

The inflatable air bag of an annular form may take another construction other than the above construction. For example, the air bag may be provided with a plurality of folding seals arranged in a closer relationship. In this case, the air bag may be inflated to have an annular form of a substantially circular cross-section. Such an air bag may be used to easily and securely fill a space of a circular or similar configuration.

As explained above, one or more folding seals are provided in each inflatable portion so as to divide the inflatable portion along the length thereof. The inflatable portions may be inflated by a single air-blow operation through the blowing tube. Thus, the air bag may be easily folded about the folding seal(s) even after the air bag has been inflated. Accordingly, the air bag may be advantageously used as a packaging material or cushioning material in wide variety of applications. Specifically, when each inflatable portion is closed in an annular form while providing each inflatable portion with two or more folding seals so that it may be folded into a polygonal configuration about the boundary between the inflatable sub-portions, it is possible for spaces between articles of a different configuration or spaces between an article and a container to be filled with a plurality of air bags in a quick and exact manner, by inserting the air bags in a flattened form into the spaces and by simply supplying air into the air bags for inflation thereof. Accordingly, cushioning and packaging operation may be advantageously performed in a quick manner. It is also noted that the position of the folding seals may be easily changed so as to change the length of the inflatable sub-portions, depending upon a shape and/or size of a given article to be packaged. This permits a space of an irregular form such as scalene triangular shape to be easily filled with the air bag, thus conveniently obviating complicated operation in prior art in which plural cushioning members of a similar type are packed into a single space. It is also possible, in accordance with the invention, to easily change the number of folding seal, at which the foldable portions are folded, so as to form any desired number of foldable, inflatable

portions which may define an air bag of a triangular, quadrangular, pentagonal or other pentagonal configuration. Thus, the air bag according to the invention may be used in a variety of applications depending upon a shape or size of a given article to be packaged.

### Claims

1. An inflatable and foldable air bag including two sheets (1, 2) of airtight film having a predetermined width, and a self-seal air blowing tube inserted between said two sheets of airtight film along the longitudinal direction of said sheets, so as to form sealed edges (3, 4) at the opposite edge of said films, said two sheets of film being sealed along plural pairs of transverse partition lines (5, 6) extending across the widths of said films, so as to form a plurality of inflatable portions (7) arranged in series in the longitudinal direction of said films, said air bag characterized by

at least one seal line (8) in each of said inflatable portions (7);  
 said seal line (8-1, 8-2) extending in the transverse direction of said films between each pair of partition lines (5, 6) for permitting said inflatable portions to be folded in the transverse direction;  
 said seal line permitting air flow into each of said inflatable portions (7);  
 said seal line (8) dividing said each inflatable portion (7) into two or more inflatable sub-portions (7-1, 7-2, ...), whereby said inflatable sub-portions may be folded about said seal line (8).

2. An inflatable and foldable air bag according to Claim 1, wherein said seal line (8) in each of said inflatable portions (7) is provided as a single continuous line, and wherein an air flow passage 9 is defined between the opposite ends of said seal line 8 and said transverse partition lines (5, 6).
3. An inflatable and foldable air bag according to Claim 1, wherein said seal line is formed as an intermittent line, so as to permit air flow between said inflatable sub-portions in each of said inflatable portions.
4. An inflatable and foldable air bag according to Claim 2 or Claim 3, wherein two seal lines (8-1, 8-2) are formed in each of said inflatable portions (7), whereby each inflatable portion (7) is divided into three foldable, inflatable sub-portions (7-1, 7-2, 7-3).
5. An inflatable and foldable air bag according to Claim 2 or Claim 3, wherein three or more seal lines (8-1, 8-2, 8-3) are formed in each of said inflatable

portions (7), whereby each inflatable portion (7) is divided into four or more foldable, inflatable sub-portions (7-1, 7-2, 7-3, 7-4, ...).

6. An inflatable and foldable air bag according to Claim 1, wherein each of said inflatable portions (37) is divided into three or more inflatable sub-portions (37-1, 37-2, 37-3, ...), and wherein at least one of said sealed edges (33, 34) is extended in the transverse direction to form a connection tab (40), whereby said sealed edges (33, 34) may be connected together so as to form a closed annular air bag, so that said air bag, when inflated, may be folded about said seal lines into a polygonal configuration.
7. An inflatable and foldable air bag according to Claim 6, wherein two seal lines (38-1, 38-2) are formed in each of said inflatable portions (37), so that each inflatable portion (37) is divided into three inflatable sub-portions (37-1, 37-2, 37-3), whereby each inflatable portion may be inflated to a hollow triangular form of a closed annular configuration.
8. An inflatable and foldable air bag according to Claim 6, wherein three or more seal lines (38-1, 38-2, 38-3, ...) are formed in each of said inflatable portions (37), so that each inflatable portion (37) is divided into four or more inflatable sub-portions (37-1, 37-2, 37-3, 37-4, ...), so that each inflatable sub-portion may be inflated to a hollow annular form of a quadrangular, polygonal, or other polygonal configuration.
9. An inflatable and foldable air bag according to any one of Claims 1 through 6, wherein each of said inflatable sub-portions has the same length.
10. An inflatable and foldable air bag according to any one of Claims 1 through 6, wherein each of said inflatable sub-portions has a different length.
11. An inflatable and foldable air bag according to Claim 1, wherein said air blowing tube is of a type in which a blowing passage 11 extends through each of said inflatable portions (7) having at least one set of partition passages (20, 21, 22) in each of said inflatable portions (37) with respective self-seal openings (13, 15, 17, 19).

### Patentansprüche

1. Aufblasbares, faltbares Luftkissen, mit zwei Folien (1, 2) aus luftdichtem Film mit vorherbestimmter Breite, und mit einem selbstdichtenden Luftzufuhrrohr, das zwischen die beiden Folien aus luftdichtem Film in Längsrichtung der Folien eingesetzt ist, so dass Dichtkanten (3, 4) an den entgegengesetz-

ten Kanten der Filme gebildet werden, wobei die beiden Filmfolien entlang mehrerer Paare quer angeordneter Trennlinien (5, 6) abgedichtet sind, welche sich jeweils über die Breite der Filme erstrecken, so dass mehrere aufblasbare Bereiche (7) gebildet werden, welche in Längsrichtung der Filme in Reihe angeordnet sind, gekennzeichnet durch

mindestens eine Dichtlinie (8) in jedem der aufblasbaren Bereiche (7),  
wobei die Dichtlinie (8-1, 8-2) sich zwischen jedem Paar von Trennlinien (5, 6) in Querrichtung der Filme erstreckt, um zu ermöglichen, dass die aufblasbaren Bereiche in Querrichtung gefaltet werden,  
wobei die Dichtlinie es ermöglicht, dass Luft in jeden der aufblasbaren Bereiche (7) fließen kann, und  
wobei die Dichtlinie (8) jeden aufblasbaren Bereich (7) in zwei oder mehrere aufblasbare Unterbereiche (7-1, 7-2, ...) aufteilt, wodurch die aufblasbaren Unterbereiche um die Dichtlinie (8) gefaltet werden können.

2. Aufblasbares, faltbares Luftkissen nach Anspruch 1, bei dem die Dichtlinie (8) in jedem der aufblasbaren Bereiche (7) als einzelne, ununterbrochene Linie vorgesehen ist, und bei dem ein Luftdurchflussweg (9) zwischen den gegenüberliegenden Enden der Dichtlinie (8) und den quer ausgerichteten Trennlinien (5, 6) definiert ist.
3. Aufblasbares, faltbares Luftkissen nach Anspruch 1, bei dem die Dichtlinie als diskontinuierliche Linie ausgebildet ist, um zu ermöglichen, dass Luft zwischen den aufblasbaren Unterbereichen in jeden der aufblasbaren Bereiche fließt.
4. Aufblasbares, faltbares Luftkissen nach Anspruch 2 oder 3, bei dem zwei Dichtlinien (8-1, 8-2) in jedem der aufblasbaren Bereiche (7) ausgebildet sind, wodurch jeder aufblasbare Bereich (7) in drei faltbare, aufblasbare Unterbereiche (7-1, 7-2, 7-3) aufgeteilt wird.
5. Aufblasbares, faltbares Luftkissen nach Anspruch 2 oder 3, bei dem drei oder mehr Dichtlinien (8-1, 8-2, 8-3) in jedem der faltbaren Bereiche (7) ausgebildet sind, wodurch jeder aufblasbare Bereich (7) in vier oder mehr faltbare, aufblasbare Unterbereiche (7-1, 7-2, 7-3, 7-4, ...) aufgeteilt wird.
6. Aufblasbares, faltbares Luftkissen nach Anspruch 1, bei dem jeder der aufblasbaren Bereiche (37) in drei oder mehr aufblasbare Unterbereiche (37-1, 37-2, 37-3, ...) aufgeteilt wird, und bei dem sich mindestens eine der Dichtkanten (33, 34) in Quer-

richtung erstreckt, so dass ein Verbindungsstreifen (40) gebildet wird, wodurch die Dichtkanten (33, 34) so miteinander verbunden werden können, dass ein geschlossenes ringförmiges Luftkissen entsteht, so dass das Luftkissen in aufgeblasenem Zustand um die Dichtlinien in polygonale Form gefaltet werden kann.

7. Aufblasbares, faltbares Luftkissen nach Anspruch 6, bei dem zwei Dichtlinien (38-1, 38-2) in jedem der aufblasbaren Bereiche (37) ausgebildet sind, so dass jeder aufblasbare Bereich (37) in drei aufblasbare Unterbereiche (37-1, 37-2, 37-3) aufgeteilt wird, wodurch jeder aufblasbare Bereich in eine hohle Dreieckform in geschlossener ringförmiger Ausführung aufgeblasen werden kann.
8. Aufblasbares, faltbares Luftkissen nach Anspruch 6, bei dem drei oder mehr Dichtlinien (38-1, 38-2, 38-3, ...) in jedem der aufblasbaren Bereiche (37) ausgebildet sind, so dass jeder aufblasbare Bereich (37) in vier oder mehr aufblasbare Unterbereiche (37-1, 37-2, 37-3, 37-4, ...) aufgeteilt wird, so dass jeder aufblasbare Unterbereich in eine hohle Ringform mit vierseitiger, polygonaler oder einer anderen polygonalen Ausführung aufgeblasen werden kann.
9. Aufblasbares, faltbares Luftkissen nach einem der Ansprüche 1 bis 6, bei dem jeder der aufblasbaren Unterbereiche die gleiche Länge hat.
10. Aufblasbares, faltbares Luftkissen nach einem der Ansprüche 1 bis 6, bei dem jeder der aufblasbaren Unterbereiche eine unterschiedliche Länge hat.
11. Aufblasbares, faltbares Luftkissen nach Anspruch 1, bei dem das Luftzufuhrrohr so ausgebildet ist, dass ein Zufuhrweg (11) sich durch jeden der aufblasbaren Bereiche (7) erstreckt, wobei mindestens ein Satz von Trennleitungen (20, 21, 22) in jedem der aufblasbaren Bereiche (37) mit entsprechenden selbstdichtenden Öffnungen (13, 15, 17, 19) vorhanden ist.

## Revendications

1. Coussin d'air pliable et gonflable comportant deux feuilles (1, 2) de film étanche à l'air ayant une largeur prédéterminée et un tube de soufflage d'air auto-scellant inséré entre lesdites deux feuilles de film étanche à l'air le long de la direction longitudinale desdites feuilles, de manière à former des bords scellés (3, 4) aux bords opposés desdits films, lesdites deux feuilles de film étant scellées le long de plusieurs paires de lignes de séparation transversales (5, 6) s'étendant au travers des larges desdits films de manière à former une plura-

lité de parties gonflables (7) agencées en série dans la direction longitudinale desdits films, ledit coussin d'air étant caractérisé par

- au moins une ligne de scellage (8) dans cha- 5  
cune desdites parties gonflables (7) ;  
ladite ligne de scellage (8-1, 8-2) s'étendant  
dans la direction transversale desdits films  
entre chaque paire de lignes de séparation (5, 6) pour permettre aux parties gonflables d'être 10  
pliées dans la direction transversale ;  
ladite ligne de scellage permettant la circula-  
tion de l'air dans chacune desdites parties gon-  
flables (7) ;  
ladite ligne de scellage (8) divisant chaque dite 15  
partie gonflable (7) en deux sous-parties gon-  
flables ou plus (7-1, 7-2, ...), de sorte que lesdi-  
tes sous-parties gonflables peuvent être pliées  
autour de ladite ligne de scellage (8). 20
2. Coussin d'air pliable et gonflable selon la revendication 1, dans lequel ladite ligne de scellage (8) dans chacune desdites parties gonflables (7) est prévue comme une ligne unique continue, et dans lequel un passage de circulation d'air (9) est défini 25  
entre les extrémités opposées de ladite ligne de  
scellage (8) et lesdites lignes de séparation trans-  
versales (5, 6).
3. Coussin d'air gonflable et pliable selon la revendication 1, dans lequel ladite ligne de scellage est formée comme une ligne discontinue, de manière à permettre la circulation d'air entre lesdites sous-parties gonflables dans chacune desdites parties gonflables. 30
4. Coussin d'air pliable et gonflable selon la revendication 2 ou 3, dans lequel deux lignes de scellage (8-1, 8-2) sont formées dans chacune desdites parties gonflables (7), de sorte que chaque partie gon- 40  
flable (7) est divisée en trois sous-parties  
gonflables pliées (7-1, 7-2, 7-3).
5. Coussin d'air gonflable et pliable selon la revendication 2, ou 3, dans lequel trois lignes de scellage ou plus (8-1, 8-2, 8-3) sont formées dans chacune desdites parties gonflables (7), de sorte que cha- 45  
que partie gonflable (7) est divisée en quatre sous-  
parties gonflables pliées ou plus (7-1, 7-2, 7-3, 7-  
4, ...). 50
6. Coussin d'air pliable et gonflable selon la revendication 1, dans lequel chacune desdites parties gon- 55  
flables (37) est divisée en trois sous-parties  
gonflables ou plus (37-1, 37-2, 37-3, ...), et dans  
lequel au moins un desdits bords scellés (33, 34)  
s'étend dans la direction transversale pour former  
une patte de connexion (40), de sorte que lesdits  
bords scellés (33, 34) peuvent être connectés de  
manière à former un coussin d'air annulaire fermé,  
de sorte que ledit coussin d'air, lorsqu'il est gonflé,  
peut être plié autour desdites lignes de scellage  
suivant une configuration polygonale.
7. Coussin d'air pliable et gonflable selon la revendication 6, dans lequel deux lignes de scellage (38-1, 38-2) sont formées dans chacune desdites parties gonflables (37), de sorte que chaque partie gonflable (37) est divisée en trois sous-parties gonflables (37-1, 37-2, 37-3), de sorte que chaque partie gonflable peut être gonflée en une forme triangulaire creuse d'une configuration annulaire fermée.
8. Coussin d'air pliable et gonflable selon la revendication 6, dans lequel trois lignes de scellage ou plus (38-1, 38-2, 38-3, ...) sont formées dans chacune desdites parties gonflables (37), de manière que chaque partie gonflable (37) est divisée en quatre sous-parties gonflables ou plus (37-1, 37-2, 37-3, 37-4, ...), de sorte que chaque sous-partie gonflable peut être gonflée en une forme annulaire creuse d'une configuration quadrangulaire, polygonale, ou tout autre polygone.
9. Coussin d'air gonflable et pliable selon l'une quelconque des revendications 1 à 6, dans lequel chacune desdites sous-parties gonflables a la même longueur.
10. Coussin d'air gonflable et pliable selon l'une quelconque des revendications 1 à 6, dans lequel chacune desdites sous-parties gonflables a une longueur différente.
11. Coussin d'air gonflable et pliable selon la revendication 1, dans lequel ledit tube de soufflage d'air est d'un type dans lequel un passage de soufflage (11) s'étend à travers chacune desdites parties gonflables (7) ayant au moins un jeu de passages de séparation (20, 21, 22) dans chacune desdites parties gonflables (37) par rapport aux ouvertures auto-scellantés respectives (13, 15, 17, 19).

FIG. 1

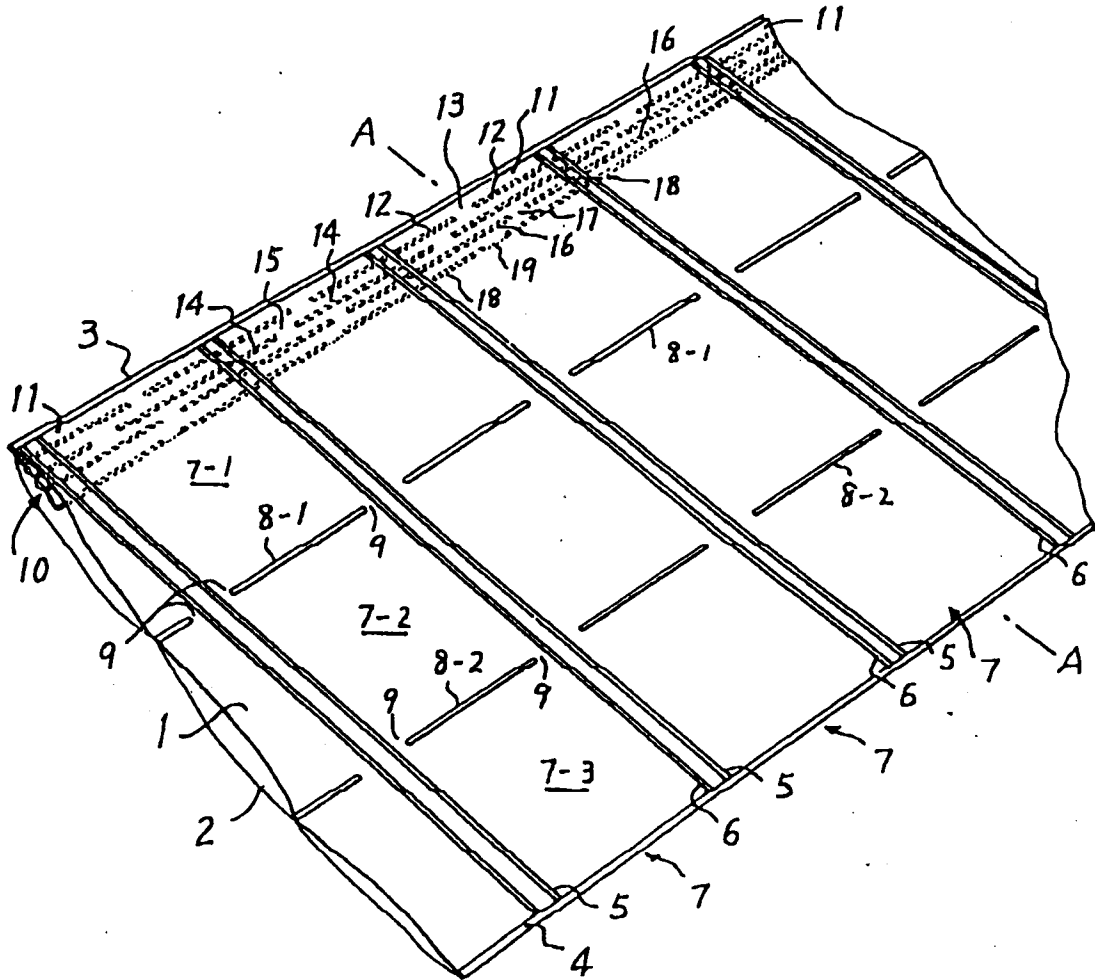

FIG. 2

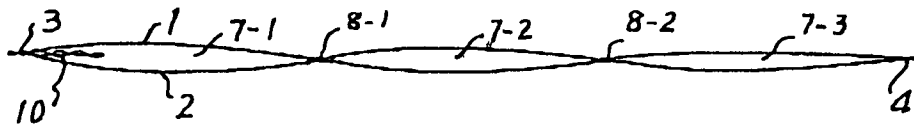

FIG. 3

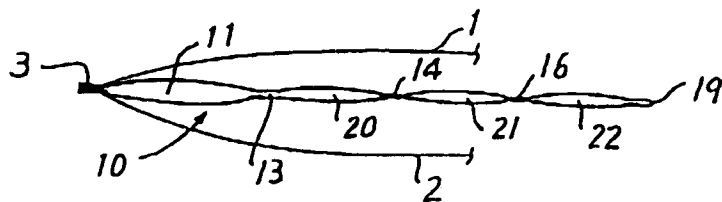

FIG. 4

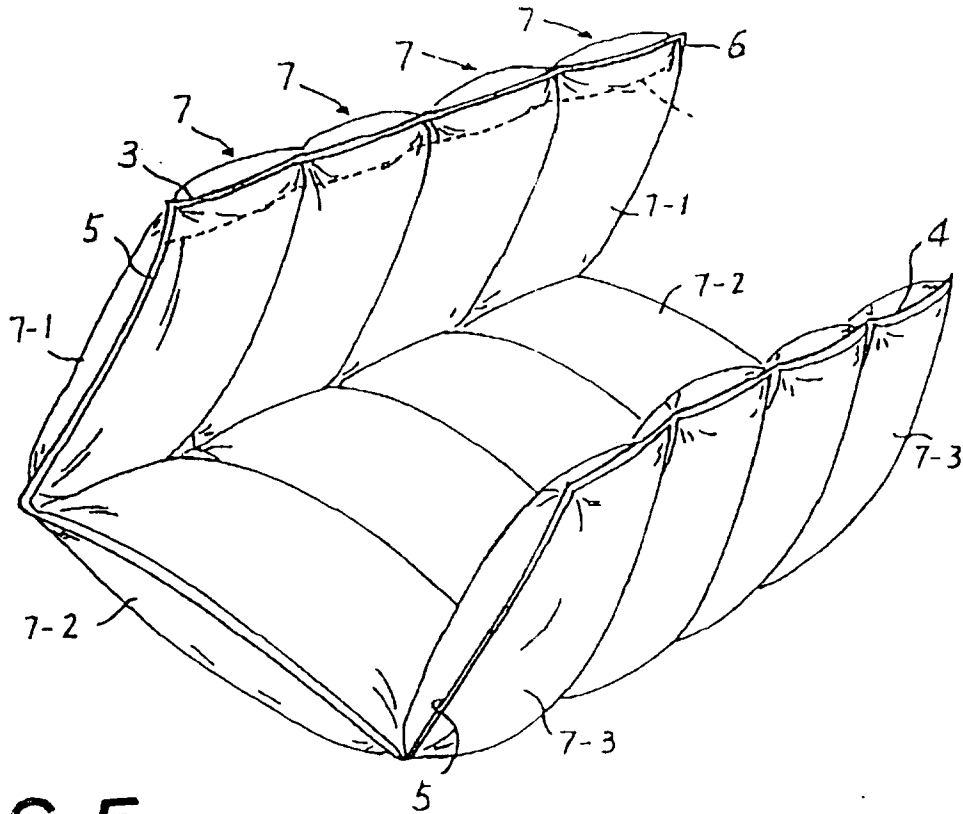

FIG. 5

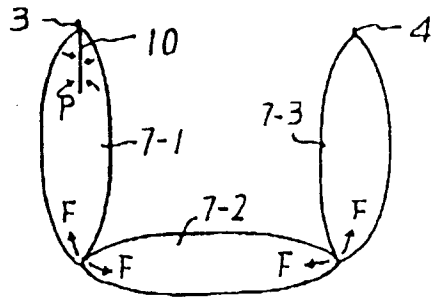

FIG. 6

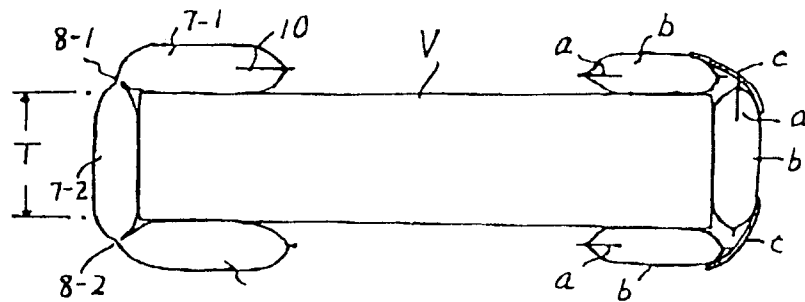

FIG. 7

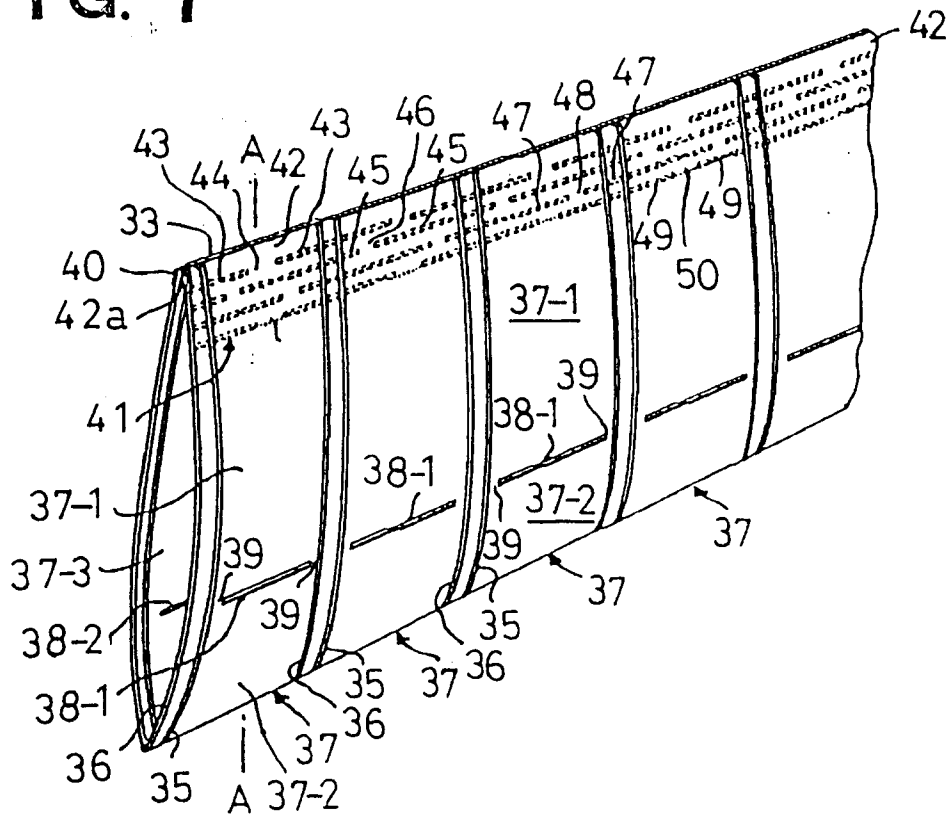

FIG. 8

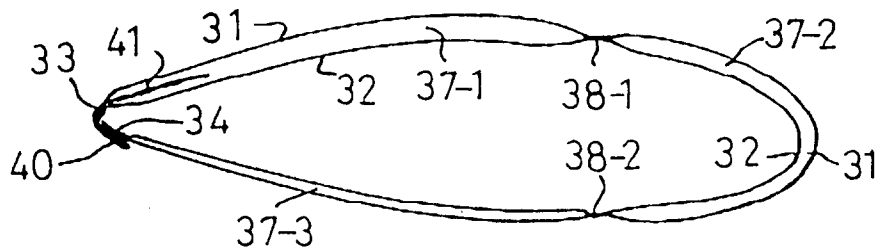

FIG. 9

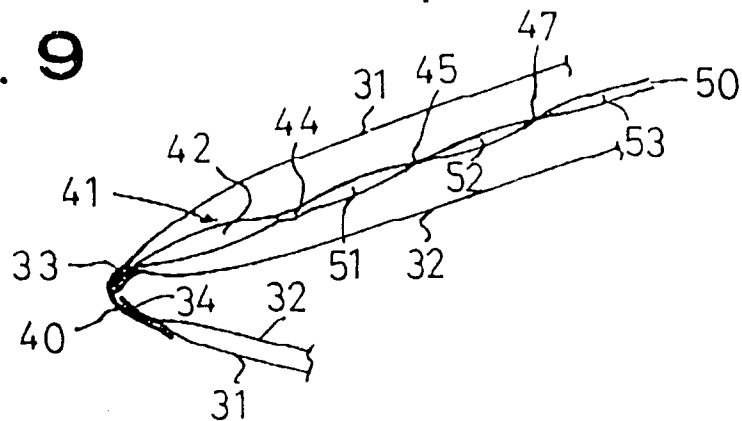

FIG. 10

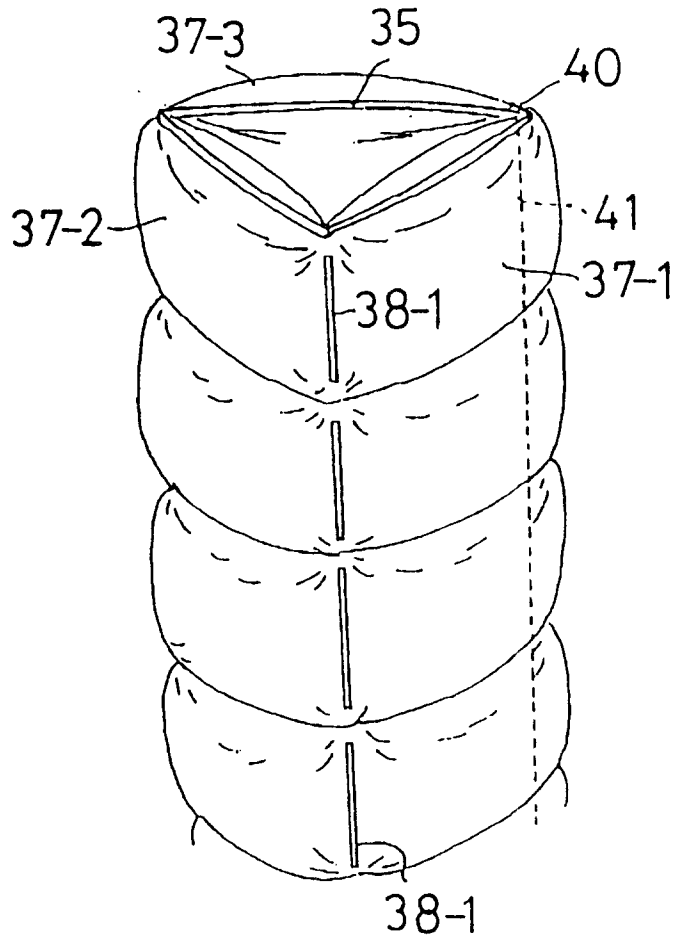

FIG. 11

