

(12) STANDARD PATENT
(19) AUSTRALIAN PATENT OFFICE

(11) Application No. **AU 2003203843 B2**

(54) Title
Improvements in or relating to tube couplings

(51) International Patent Classification(s)
F16L 19/08 (2006.01) **F16L 37/092** (2006.01)

(21) Application No: **2003203843** (22) Date of Filing: **2003.04.23**

(30) Priority Data

(31) Number	(32) Date	(33) Country
0209897.8	2002.04.30	GB

(43) Publication Date: **2003.11.20**

(43) Publication Journal Date: **2003.11.20**

(44) Accepted Journal Date: **2008.04.03**

(71) Applicant(s)
John Guest International Limited

(72) Inventor(s)
Guest, John Derek

(74) Agent / Attorney
Davies Collison Cave, 1 Nicholson Street, Melbourne, VIC, 3000

(56) Related Art
US 3909046
EP 945662

ABSTRACT OF THE DISCLOSURE

5 A tube coupling has a coupling body (12) with a
throughway (13) open at one end to receive an end
portion of a tube (11). A seal (50) encircles the
throughway to seal with the periphery and end of the
tube and a cap (20) is mounted on the body having a
10 tube locking device (23) rotatably mounted in the cap
to engage and hold the tube in the cap. The cap and
body have interengaging means (24, 25, 26, 27) which
guide the cap on the body in an axial direction along
the body with rotation of the cap from a first
15 position in which a tube can be inserted through the
cap and into the seal in the throughway and retained
by the locking device and a second position advanced
along the coupling body from said one end in which the
tube end is held positively in engagement with the
20 seal in the throughway. The locking device (23)
engages via a ring with the coupling body to resist
rotation of the locking device with respect to the
body whereby rotation of the cap between said the
first and second positions does not cause the tube to
25 rotate.

AUSTRALIA
PATENTS ACT 1990
COMPLETE SPECIFICATION

NAME OF APPLICANT(S)::

John Guest International Limited

ADDRESS FOR SERVICE:

DAVIES COLLISON CAVE
Patent Attorneys
1 Little Collins Street, Melbourne, 3000.

INVENTION TITLE:

Improvements in or relating to tube couplings

The following statement is a full description of this invention, including the best method of performing it known to me/us:-

2003203843 20 Feb 2008

- 1a -

The invention relates to tube couplings. Examples of the invention seek to provide a coupling with enhanced sealing for the tube without voids between the tube and coupling surfaces in which fluids may be trapped and fester.

EP-A-1233225 discloses a tube coupling to receive and hold a tube comprising a coupling body having a throughway open at one end to receive a tube. An annular step is formed in the throughway facing the open end to receive an end of a tube. An end cap is screwed on to the coupling body for axial movement between forward and retracted position on the coupling body, the end cap having an opening for the tube to extend through. A seal is located in the coupling body between the step and the open end of the body. The seal has an annular sleeve encircling the throughway and an out-turned annular flange at one end lying against the annular step to receive and seal with an end of the tube inserted into the throughway. A compression device in the throughway is operable to compress the sleeve around the outer surface of the tube adjacent said end of the tube as the end cap is screwed on to the coupling body into the forward position.

In accordance with the present invention, there is provided a tube coupling comprising a coupling body having a throughway open at one end to receive an end portion of a tube, a seal encircling the throughway and a cap mounted on the coupling body having a tube

- 2 -

locking device rotatably mounted therein to engage and hold a tube in the cap in the axial direction of the cap, the cap and coupling body having interengaging means which are suitable to guide the cap along the coupling body in an axial direction during rotation of the cap from a first position in which a tube can be inserted through the cap and into the seal in the throughway and retained by the locking device and a second position located axially further along the coupling body from the end thereof than said first position, whereby, when a tube is inserted into the cap and the cap is rotated into the second position, the tube end is held positively in engagement with the seal in the throughway, wherein the seal is adapted to receive and seal with both the periphery and end of a tube held by the coupling and means are provided to resist rotation of the locking device with respect to the coupling body whereby rotation of the cap between said first and second positions does not cause a tube held by the locking device to rotate, with respect to the coupling body.

An example tube coupling comprises a coupling body having a throughway open at one end to receive an end portion of a tube, a seal encircling the throughway to seal with the periphery and end of the tube and a cap mounted on the body having a tube locking device rotatably mounted therein the cap to engage and hold the tube in the cap in the axial direction out of the cap, the cap and body having interengaging means which

2003203843 20 Feb 2008

2003203843 20 Feb 2008

guide the cap on the body in an axial direction along the body with rotation of the cap from a first position in which a tube can be inserted through the cap and into the seal in the throughway and retained by the locking device and a second position advanced along the coupling body from the end thereof in which the tube end is held positively in engagement with the seal in the throughway, wherein means are provided to resist rotation of the locking device with respect to the coupling body whereby rotation of the cap between said the first and second positions does not cause the tube to rotate.

In a preferred arrangement an annular member is provided in the cap acting between the coupling body and tube locking device to resist rotation of the locking device with respect to the coupling body.

More specifically, the annular member and an end of the coupling body have interengaging teeth to resist rotation of the annular member with respect to the coupling body.

Furthermore, wherein the annular member and the tube locking device may have interengaging teeth to resist rotation of the locking device with respect to the coupling body.

In one particular construction the annular member may comprise a sleeve which engages in the open end of the throughway of the coupling body and has an out-

2003203843 20 Feb 2008

- 3a -

turned flange overlying the end of the coupling body,
the end of the coupling body and side of the flange
facing the coupling body having interengaging teeth to
resist rotation of the annular member with respect to
5 the coupling body and the other side of the flange and
tube locking device having interengaging teeth to
resist rotation of the tube locking device with respect
to the coupling body.

In any of the above arrangements the locking
10 device may comprise a collet having an annular head
located on the outer side of the cap and having a
plurality of resilient arms projecting into the cap,
the arms having interengaging teeth for engaging the
tube extending through the collet into the coupling
15 body and the cap having a tapered cam surface
converging towards the open end of the cap remote from
the coupling body with which the arms of the collet are
engagable to be pressed inwardly with outward movement
of the collet with respect to the cap to engage and
20 grip the tube extending through the collet.

In the latter arrangement the ends of the arms of
the collet projecting into the cap may have teeth for
interengaging with the teeth of the annular member for
resisting rotation of the collet with the cap.

25 The invention is described, by way of non-limiting
example only, with reference to the accompanying
drawings in which:

- 3b -

Figure 1 is an exploded view of an inline tube coupling having identical tube connectors at each end thereof;

Figure 2 is a cross-sectional view through the coupling of Figure 1 with the components of the
5 coupling fully assembled with tubes, one tube being located in an initial engagement position and the other being fully engaged;

Figure 3 is an enlarged view of part of the
10 coupling of Figure 2 showing said one tube in the initially engaged position; and

2003203843 20 Feb 2008

Figure 4 is a similar view to Figure 3 showing the other tube in the fully engaged position; and

Figure 5 is a cut-away perspective view of a modified form of the connector.

5

Referring firstly to Figure 1 of the drawing, there is shown a double ended inline tube coupling indicated generally at 10 for connecting together two inline tubes indicated at 11 in Figure 2.

10

The coupling comprises a central cylindrical coupling body 12 having a throughway 13 and an integral annular internal wall 14 located centrally in the throughway with a central aperture 15 for flow of fluid from tube to tube through the coupling.

15

The outer side of the coupling body has an encircling outer wall 16 formed integrally with the coupling body centrally along the body. The periphery of the outer wall is formed with four equally spaced abutments extending across the outer periphery of the wall and between the abutments the wall has shallow recesses. The raised abutments provide finger grips to enable the coupling body to be held against rotation during assembly and disassembly of tubes with the coupling as described later.

20

25

End caps 20 are engagable over the portions of the coupling body to either side of the central wall. The end caps are generally of cylindrical form having an open end 21 to receive an end portion of the cylindrical body 12 and having a reduced diameter socket 22 at the other end in which a collet 23 is engagable to receive and lock a tube in the end cap as describe later.

30

35

The open end 21 of the end cap has two shallow

lugs 24 formed integrally with the wall of the end cap at diametrically spaced locations across the end cap. Each end portion of the cylindrical body 12 has in its outer surface axially extending grooves 25 formed at diametrically spaced locations around the coupling body leading towards the central wall 16. The grooves are dimensioned to receive the lugs 24 on the inner surface of the cap with a close fit and to guide the cap axially onto the coupling body.

5
10

Near to the central wall 16 the grooves 25 lead into helically wound grooves 26 extending a short distance of approximately one quarter of the circumference around the cylindrical body. The grooves 26 are dimensioned to receive the abutments 24 in the cap to allow the cap to rotate and at the same time to advance axially with respect to the coupling body. The grooves 26 run out at the wall 16 in a short end section 27 parallel to the wall which terminates with an end stop 28 at the end of the groove. The side of each groove remote from the wall is formed with a shallow projection where the groove changes from the helical portion 26 to the end section 27 to retain the abutment 24 in the parallel section of the groove adjacent the end.

15
20

25

The axial portion of the groove 25 has a shallow ramp 30 over which the abutment 24 rides immediately before entering the helically groove section 26. The ramps serve to define a first position of assembly of the cap 20 on the coupling body and to retain the cap on the coupling body.

30

Thus in assembling the cap 20 on the coupling body, the cap is initially moved axially onto the coupling body with the abutments 24 sliding along the groove 25 and snapping over the ramps 30. Once past

35

the ramps 30, the cap is then rotated along the helical grooves 26 until it engages in the straight section 27 where it is retained by the projections 29. The arrangement of grooves on the coupling body and abutments in the cap define a first position of location of the cap on the coupling body in which the abutments have just snapped past the ramps in the grooves 25 and a second position in which the cap is rotated through a quarter turn on the coupling body to bring the abutments 24 into engagement with the end sections 28 of the grooves and against the end stop 29. To assist in rotating the cap with respect to the coupling body, the cap has a plurality of axially extending ribs 35 at spaced locations around its outer surface.

As indicated earlier, each cap 20 has a reduced diameter socket 22 at the end remote from the coupling body in which the collet 23 is located to receive and lock a tube in the cap. Each collet 23 comprises an annular portion 40 having a plurality of axially extending spaced resilient arms 41 projecting into the cap and an out turned head 42. The arms 41 have inturned teeth to engage and grip a surface of a tube passing through the collet and have heads 44 at the ends of the arms to engage in an internal tapered frusto-conical cam surface formed in the tapered portion of the cap between the main part and reduced diameter socket 21. Engagement of the heads of the arms with the cam surface causes the arms to be compressed inwardly with outward movement of the collet from the cap to press the teeth of the arms firmly into gripping engagement with the tube and thereby resist withdrawal of a tube from the coupling body.

An arrangement of seals is provided in the

throughway 12 in the coupling body to one side of the inner annular wall 11 as follows. Adjacent the wall there is an annular seal 50 having an outer sleeve which extends around the throughway and is dimensioned to receive the end of a tube to be sealed in the coupling body. The sleeve has a short inner sleeve formed integrally with the outer sleeve to receive an end face of the tube projecting into the outer sleeve and form a seal therewith. The sleeve 50 is lodged against and supported by the inner central wall 11.

Next to the sleeve 50 there is a ring member 60 one side 61 which abuts the sleeve and the other side of which has an encircling flange 62 formed with spaced axially facing teeth 64 on both sides thereof. The ring 60 projects into the open end of the coupling body 12 and the teeth 63 mesh with corresponding teeth 65 formed on the end face of the coupling body to prevent rotation of the ring with respect to the coupling body. Likewise the ends of the arms 41 of the collet are formed with teeth 67 which mesh with the teeth 64 on the flange 62 so that when the collet is in engagement with the flange, the cap can be rotated on the coupling body as described earlier without causing the collet 23 to rotate.

As best seen in the left hand part of the coupling of Figure 2 and the enlarged view of Figure 3, a tube is assembled in the coupling body with a cap 20 positioned in the first position defined above in which the abutments 24 in the cap are snapped over the ramps in the grooves 25 but the cap is not advanced further on the coupling body at that stage. The tube to be connected to the coupling body is aligned with the open end of the cap and is inserted through the collet 23 in the cap, through the ring 60, and into the seal 50 in the throughway. The collet

automatically grips and retains the tube to prevent the tube from being withdrawn from the coupling body.

5 The cap 20 is then rotated through the helical path defined by the grooves 26 to the position shown in the right hand part of Figure 2 and in Figure 4 and in so doing is drawn axially along the coupling body. The tube held by the collet is forced further into the throughway in the coupling body and is pressed firmly
10 into the seal with the end of the tube engaging the inner seal. Ultimately the abutments 24 in the cap reach the end portions of the groove and are retained by the shallow projections referred to earlier to hold the cap in the second position of movement with the
15 end of the tube held firmly sealed at the end of the tube by the inner seal and around the outer surface of the tube by the outer seal and O-ring seal.

20 Because the cap 20 rotates independently of the collet and tube as describe earlier, the tube does not damage the seals in the coupling body as it is forced into full sealing engagement with the seals.

25 When it is required to detach a tube from the tube coupling, the cap is rotated in the opposite direction back to the first position in its movement at the ends of the axial portions of the groove. The corresponding axial movement of the tube with the cap slightly releases the engagement of the end of the
30 tube in the seal and the collet 23 can then be depressed into the cap to release the gripping engagement of the collet arms with the tube and to allow the tube to be extracted from the coupling body/cap.

35 The arrangement at the other end of the cap is identical and like parts have been allotted the same

reference numerals. It will be appreciated that the arrangement is equally applicable to single tube couplings, elbows, T-joints and any other form of a coupling where a tube is required to be connected to another tube or other device.

5 It will be appreciated that many modifications may be made to the above described example without departing from the scope of the invention. For example, an annular spacer and an O-ring may be located next to the sleeve in the throughway to receive and encircle a tube extending into the coupling body. The ring member 60 then abuts
10 the other side of the O-ring to provide an additional seal between the tube and coupling body.

Figure 5 of the drawings shows a modified arrangement of the coupling in which ring 60 is omitted and the cap 20 is located on coupling body 12 by means of a coarse screw-thread indicated at 70.
15 The teeth 67 on the ends of the arms of the collet engage directly with the teeth 65 at the end of the coupling body. Thus the separate ring 60 of the first example is eliminated. The construction is otherwise the same as that described earlier.

Throughout this specification and the claims which follow,
20 unless the context requires otherwise, the word "comprise", and variations such as "comprises" and "comprising", will be understood to imply the inclusion of a stated integer or step or group of integers or steps but not the exclusion of any other integer or step or group of integers or steps.

25 The reference in this specification to any prior publication (or information derived from it), or to any matter which is known, is not, and should not be taken as an acknowledgment or admission or any form of suggestion that that prior publication (or information derived from it) or known matter forms part of the common general knowledge in the
30 field of endeavour to which this specification relates.

THE CLAIMS DEFINING THE INVENTION ARE AS FOLLOWS:

2003203843 20 Feb 2008

1. A tube coupling comprising a coupling body having a throughway open at one end to receive an end portion of a tube, a seal encircling the throughway and a cap mounted on the coupling body having a tube locking device rotatably mounted therein to engage and hold a tube in the cap in the axial direction of the cap, the cap and coupling body having interengaging means which are suitable to guide the cap along the coupling body in an axial direction during rotation of the cap from a first position in which a tube can be inserted through the cap and into the seal in the throughway and retained by the locking device and a second position located axially further along the coupling body from the end thereof than said first position, whereby, when a tube is inserted into the cap and the cap is rotated into the second position, the tube end is held positively in engagement with the seal in the throughway, wherein the seal is adapted to receive and seal with both the periphery and end of a tube held by the coupling and means are provided to resist rotation of the locking device with respect to the coupling body whereby rotation of the cap between said first and second positions does not cause a tube held by the locking device to rotate, with respect to the coupling body.

25

2. A tube coupling as claimed in claim 1, wherein an annular member is provided in the cap to act between the coupling body and the tube locking device to resist rotation of the tube locking device with respect to the coupling body.

30

2003203843 20 Feb 2008

3. A tube coupling as claimed in claim 2, wherein the annular member and an end of the coupling body have interengaging teeth to resist rotation of the annular member
5 with respect to the coupling body.

4. A tube coupling as claimed in claim 3, wherein the annular member and tube locking device have interengaging teeth to resist rotation of the tube locking device with
10 respect to the coupling body.

5. A tube coupling as claimed in any one of claims 2 to 4, wherein the annular member comprises a sleeve which engages in the open end of the throughway of the coupling body and
15 has an out-turned flange overlying the end of the coupling body, the end of the coupling body and side of the flange facing the coupling body having interengaging teeth to resist rotation of the annular member with respect to the coupling body and the other side of the flange and tube
20 locking device having interengaging teeth to resist rotation of the tube locking device with respect to the coupling body.

6. A tube coupling as claimed in claim 1, wherein the tube
25 locking device comprises a collet having an annular head located on the outer side of the cap and having a plurality of resilient arms projecting into the cap, the arms having teeth for engaging a tube extending through the collet into the coupling body and the cap having a tapered cam surface
30 converging towards the open end of the cap remote from the

2003203843 20 Feb 2008

- 12 -

coupling body with which the arms of the collet are engageable to be pressed radially inwardly as a result of axially outward movement of the collet with respect to the cap to engage and grip a tube extending through the collet.

5

7. A tube coupling as claimed in claim 6, wherein the ends of the arms of the collet projecting into the cap have teeth for interengaging with teeth of an annular member for resisting rotation of the collet with respect to the annular

10

member.
8. A tube coupling, substantially as hereinbefore described with reference to the accompanying drawings.

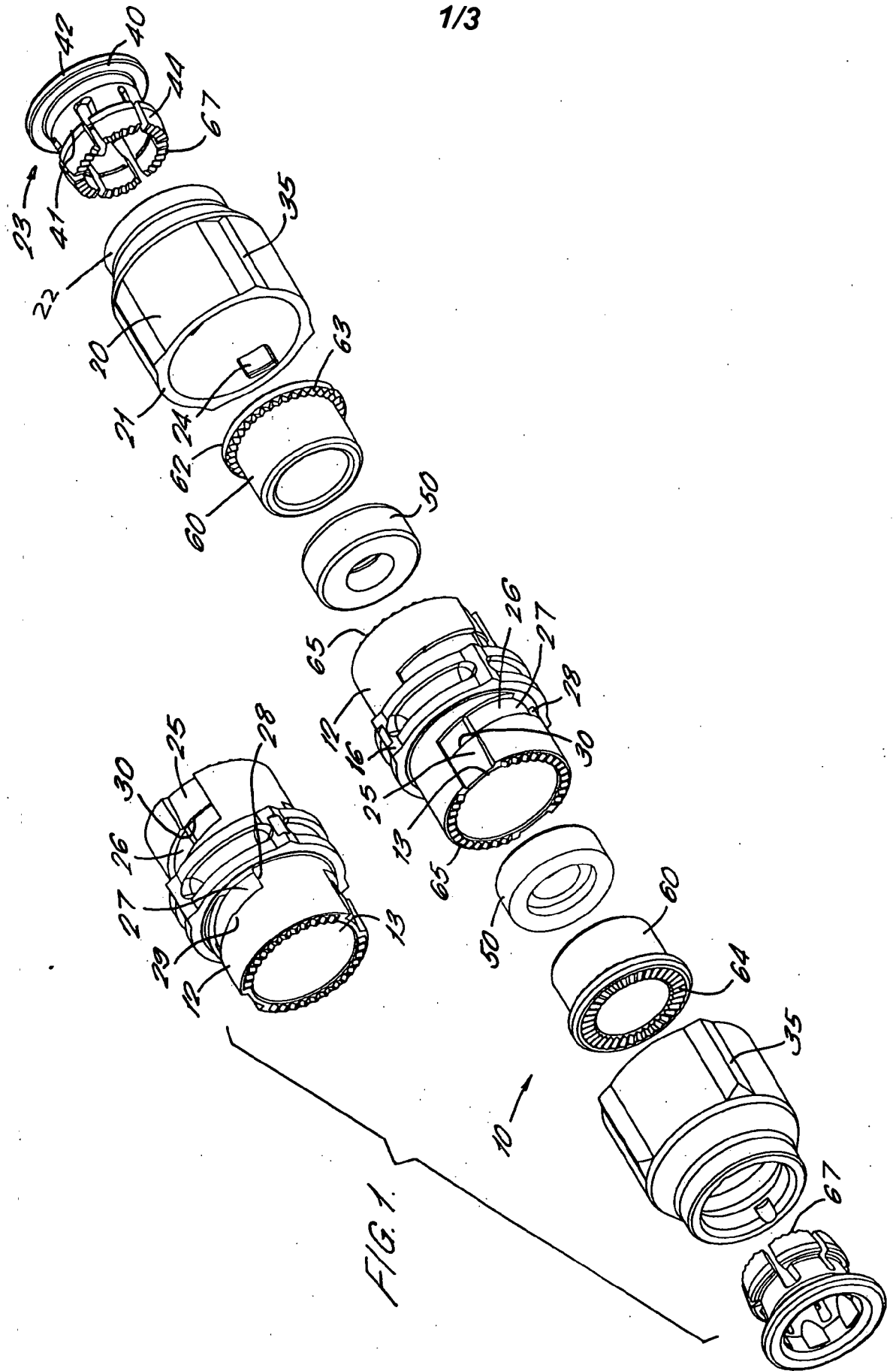

FIG. 1.

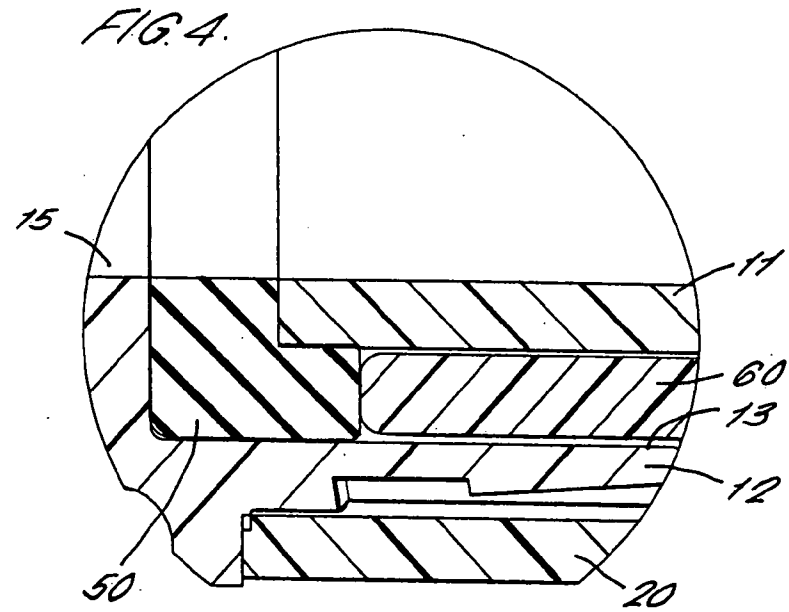
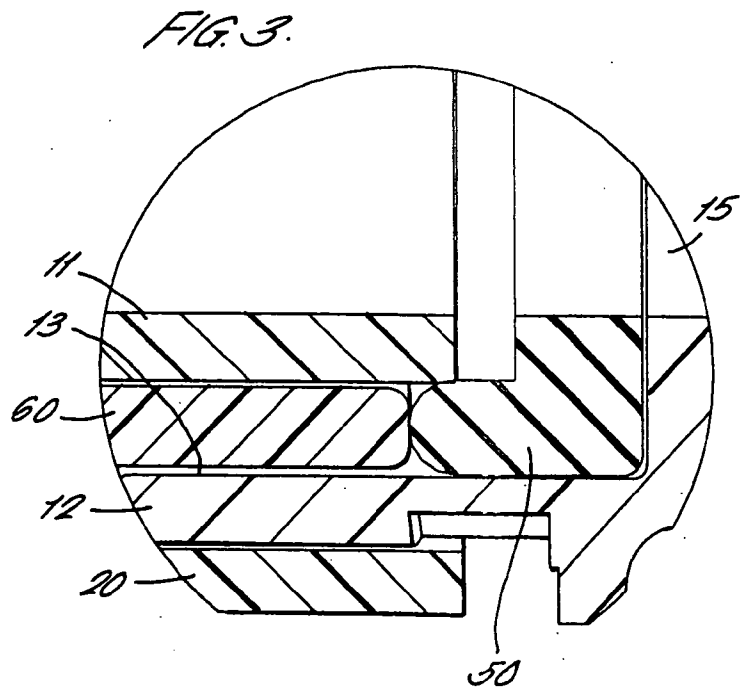
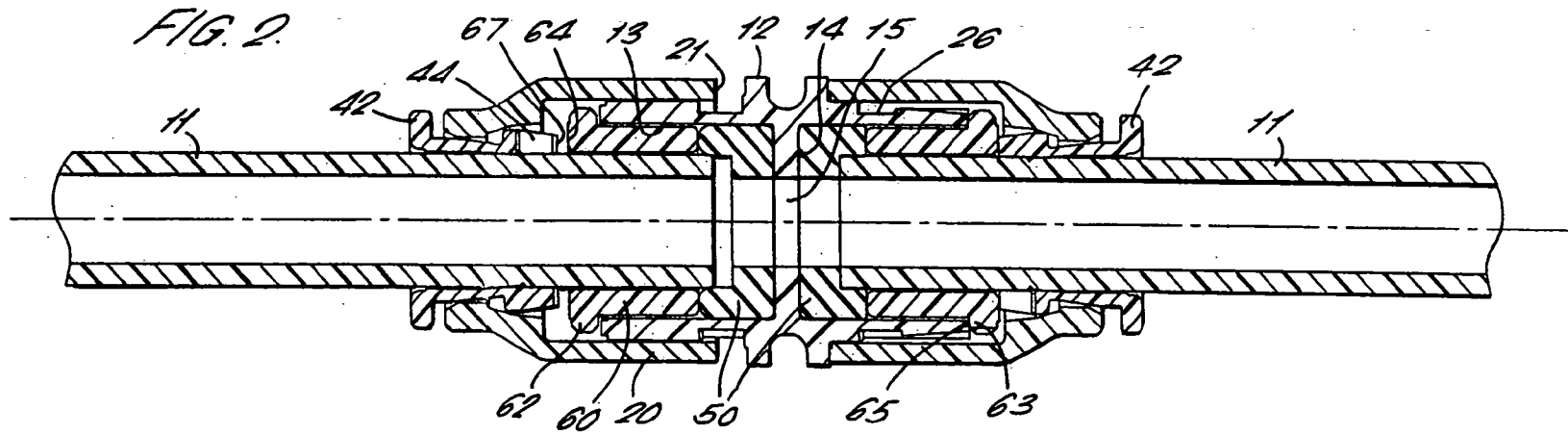

FIG. 5.

