



US 20030097872A1

(19) **United States**

(12) **Patent Application Publication**
Granitz et al.

(10) **Pub. No.: US 2003/0097872 A1**

(43) **Pub. Date: May 29, 2003**

(54) **SYSTEM FOR REDUCING OIL CONSUMPTION IN GAS TURBINE ENGINES**

Publication Classification

(76) Inventors: **Charles Robert Granitz**, Loveland, OH (US); **Mark Eden Zentgraf**, Cincinnati, OH (US)

(51) **Int. Cl.⁷** **G01L 3/26**
(52) **U.S. Cl.** **73/116**

Correspondence Address:
GENERAL ELECTRIC COMPANY
ANDREW C HESS
GE AIRCRAFT ENGINES
ONE NEUMANN WAY M/D H17
CINCINNATI, OH 452156301

(57) **ABSTRACT**

A system for reducing oil usage from a sump in a gas turbine engine. Two sources of oil usage, which usage includes leakage and consumption, have been identified: (1) during idle, leakage of oil from an oil sump through seals and (2) during high-power operation, consumption of oil entrained in vent air exiting from the sump. At idle, the invention reduces pressure in the sump, to thereby increase airflow across the seals into the sump, to inhibit the oil leakage across the seals. At high power operation, the pressure reduction is terminated, but flow exiting the vent is artificially restricted.

(21) Appl. No.: **09/998,432**

(22) Filed: **Nov. 29, 2001**

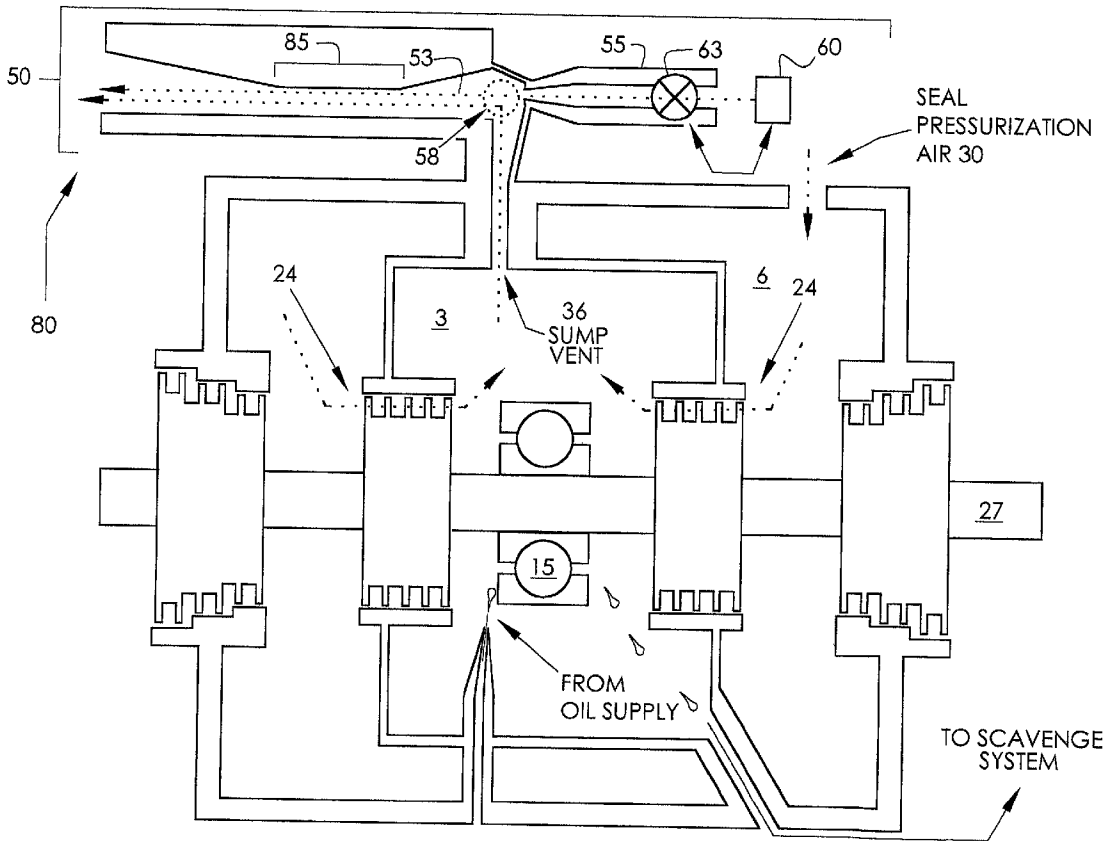

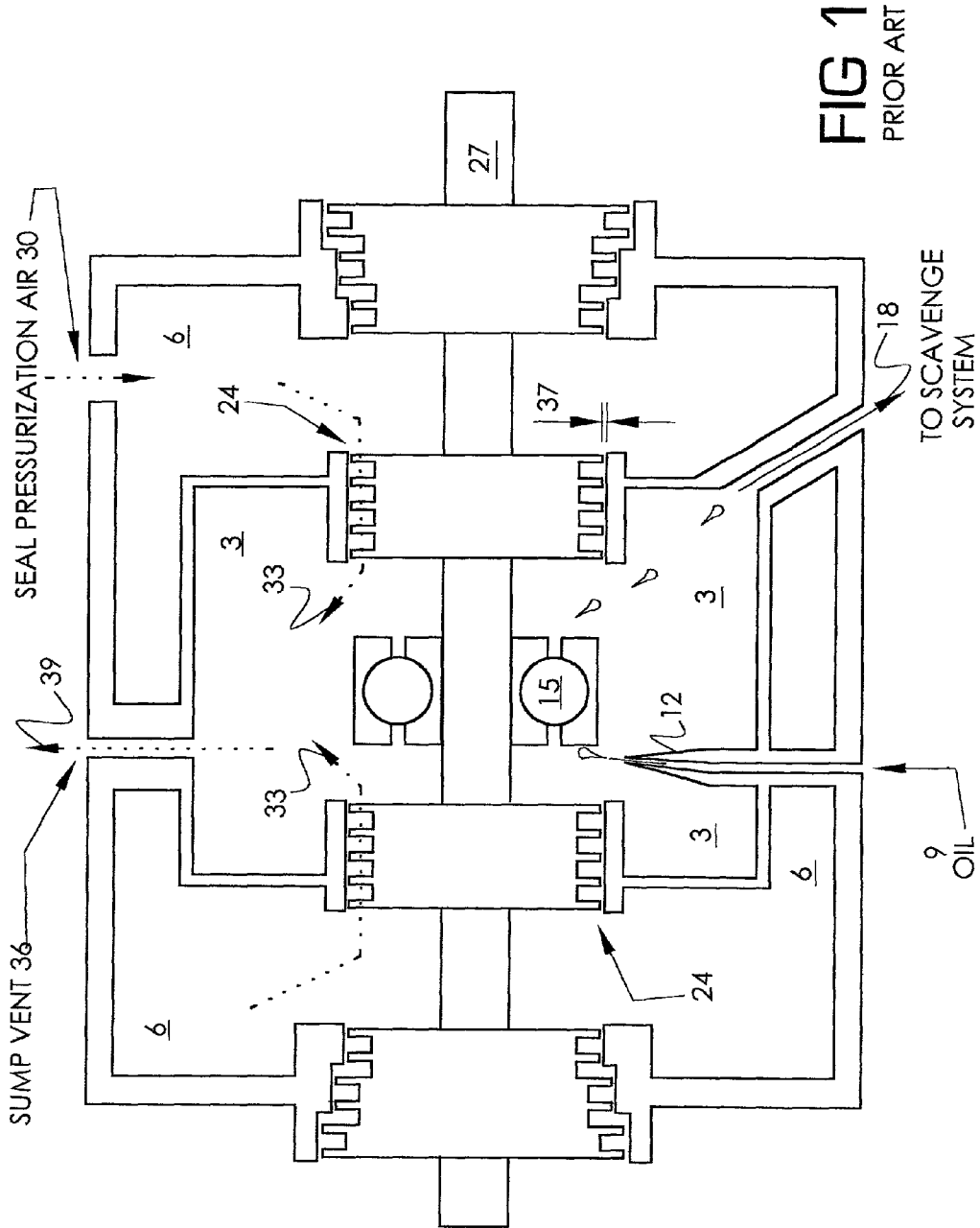

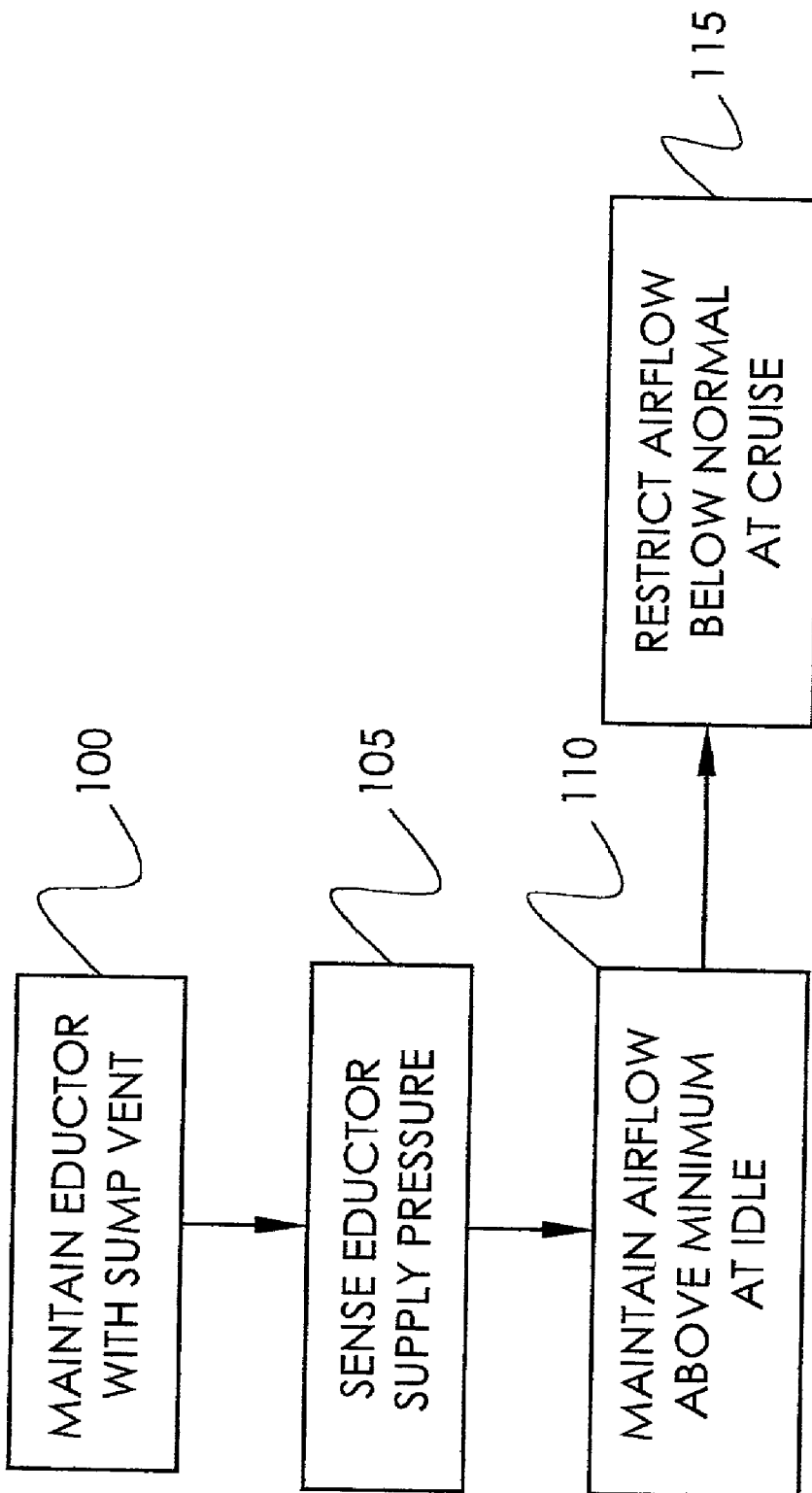

FIG 3

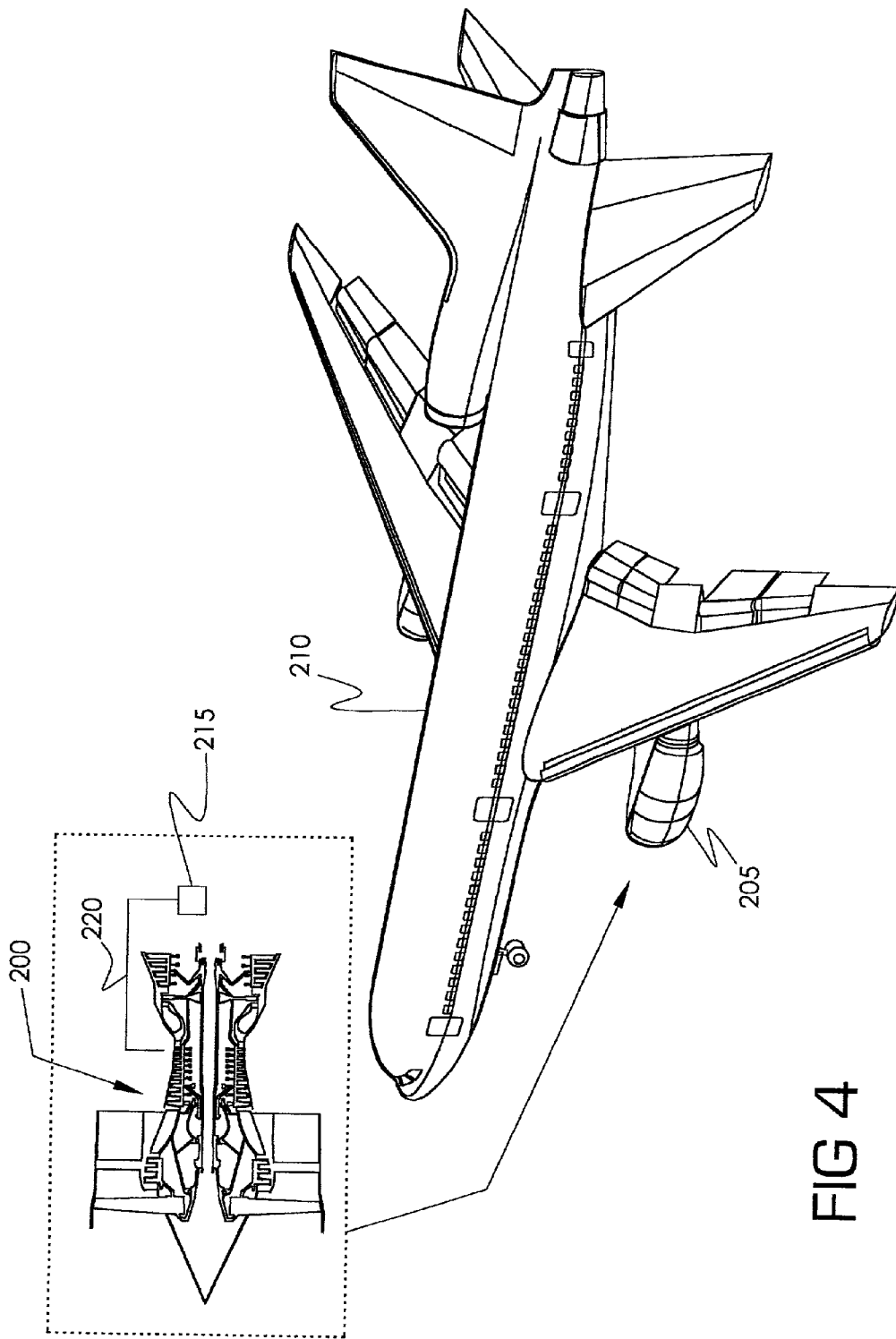

FIG 4

SYSTEM FOR REDUCING OIL CONSUMPTION IN GAS TURBINE ENGINES

TECHNICAL FIELD

[0001] The invention reduces losses of lubricating oil in a gas turbine engine due to leakage through (1) seals in an oil sump at low power and (2) a vent system of the sump at high power.

BACKGROUND OF THE INVENTION

[0002] FIG. 1 is a simplified schematic of a sump system in a gas turbine engine. Items 3 represent a common oil-wetted chamber, called the bearing sump chamber or cavity, and items 6 represent a second, different common chamber, called the sump pressurization chamber.

[0003] Oil 9 is delivered by a nozzle 12 to a bearing 15 for lubrication and cooling. After usage by the bearing 15, the oil is gravity-drained to the bottom of in the sump chamber 3, and then evacuated by a scavenge system (not shown), as indicated by arrow 18. The scavenged oil is cooled, filtered, returned in oil stream 9.

[0004] Because of windage and splashing, some oil contained in the sump chamber 3 will ordinarily tend to leak into the sump pressurization chamber 6. To inhibit this leakage, various rotating seals 24, supported by a rotating shaft 27, isolate the sump chamber 3 from the pressurization chamber 6. Since the seals 24 do not perfectly block oil migration, airflow is generated across the seals 24 to further inhibit oil migration.

[0005] To generate this airflow, incoming air, represented by dashed arrow 30, pressurizes the pressurization chamber 6. This air is driven through the seals 24 by the positive pressure differential across the seals, as indicated by dashed arrows 33. This pressurization air velocity serves to keep splashing oil out of the seals 24 in the sump chamber 3, and to reduce its migration into the pressurization chamber 6.

[0006] The pressurization air, now present within the sump chamber 3, then exits through a sump vent 36, as indicated by dashed arrow 39, after passing through an air/oil separator (not shown).

[0007] The Inventors have observed that this approach is not necessarily optimal in modern gas turbine engines which are designed to produce larger thrusts than previously.

SUMMARY OF THE INVENTION

[0008] In one form of the invention, pressure in the sump chamber is artificially reduced during engine idle, to increase the positive pressure differential across the seals, to thereby increase airflow velocity across the seals. In another form of the invention, flow exiting the sump chamber is artificially inhibited during high-power operation, to reduce flow through a constriction 85 in FIG. 2, which is located at the exit of the sump chamber.

BRIEF DESCRIPTION OF THE DRAWINGS

[0009] FIG. 1 illustrates a sump system in the prior art.

[0010] FIGS. 2 and 4 illustrate two forms of the invention.

[0011] FIG. 3 is a flow chart illustrating processes undertaken by one form of the invention.

DETAILED DESCRIPTION OF THE INVENTION

[0012] The Inventors have observed two problems in the system of FIG. 1, when used in a relatively large gas turbine engine, of the 90,000 pound thrust class. One problem is that, at idle speeds, the pressure differential between the sump pressurization cavity 6 and the sump chamber 3 is too small to provide sufficient airflow velocity across seals 24. Thus, oil leakage across seals 24 can occur: oil leaks across the seals 24 in the direction opposite to dashed arrows 33.

[0013] A second problem is that, at high-power operation, significant oil is lost through the vent 36. It is suspected that this latter loss arises because of a combination of factors. One factor is that the seals 24 are of larger diameter than previous seals of their type, thus presenting a larger cross-sectional area which must be sealed. This larger cross-sectional area provides greater flow into sump 3, thus providing greater flow through vent 36.

[0014] A second factor is that the larger seals 24 have a larger clearance. That is, the distance corresponding to distance 37 in FIG. 1 is larger. Larger clearances generally imply larger leakage.

[0015] A third factor is that the pressure differential across the seals 24 may be larger than in previous cases. A fourth factor is an increased temperature of the region of the seal 24.

[0016] In overview, one form of the invention mitigates both (1) leakage across the seals 24 at idle and (2) leakage through the vent 36 at high power. The invention does so by (1) artificially increasing the pressure differential between chambers 3 and 6 during idle operation, with chamber 3 being evacuated to a smaller pressure, and (2) restricting flow through vent 36 during high-power operation.

[0017] This is contrary to the operation of the system shown in FIG. 1, wherein a given pressure differential exists between chambers 3 and 6 at idle operation, and that pressure differential increases as engine power increases, thereby increasing flow through the vent 36.

[0018] FIG. 2 illustrates one form of the invention, in schematic form. An eductor 50, also called an air jet ejector, creates a lower pressure in sump chamber 3 than would otherwise prevail. The eductor 50 is powered by a jet 53 of air delivered by a nozzle 55. The nozzle 55 receives pressurized air from a compressor bleed (not shown in FIG. 2, but shown in FIG. 4 and discussed later).

[0019] Eductors in general are known in the art. Their operation can be understood by the following two principles, which may actually be two different statements of a single more fundamental principle. As to one principle, the eductor 50 entrains air present in region 58 into the jet 53, thereby removing the entrained air from region 58. The removal causes additional air to flow from the sump chamber 3, through the sump vent 36, to replace the removed air. As to the other principle, the jet 53 generates a low static pressure in region 58, based on Bernoulli's Law, which causes air to flow from the sump chamber 3 through sump vent 36.

[0020] Accordingly, the eductor **50**, by removing air from the sump chamber **3**, creates a lower-than-normal pressure in the sump chamber **3**, thereby increasing the pressure differential from the second chamber **6** to the sump chamber **3**. This increased differential will increase airflow velocity across seals **24**, thereby more effectively preventing oil from entering seals **24** and thus leaking from the sump chamber **3**.

[0021] A gauge-type pressure sensor **60** measures the pressure differential. When the differential falls below a specific threshold, the sensor **60** opens a valve **63**, which initiates the jet **53**, and brings the eductor **50** into operation. When the differential rises above a floor, the sensor **60** closes the valve **63**, thereby terminating operation of the eductor **50**.

[0022] The threshold and the floor may be the same, thus providing a simple set-point type of operation. Alternately, they may be different, in which case a type of hysteresis or dead band would be introduced.

[0023] The preceding mode of operation is used at engine idle speeds. At high-power conditions, such as during cruise operation of an aircraft, the eductor **50** remains inactive, because the pressure differential is above the floor described above. However, as the Background of the Invention pointed out, under these high-power conditions, excess airflow through the sump vent **36** is believed to cause undesirable oil consumption, as by entraining oil in the airflow passing through the vent **36**.

[0024] To inhibit this oil consumption, the mixing throat of eductor **50** is designed to provide an exit path restriction to the air exiting the sump vent **36**.

[0025] Eductor **50** is designed to present a flow-limiting restriction, represented by constriction **85**. This restriction limits the amount of airflow passed by the eductor **50** during high-power operation, when valve **63** is closed.

[0026] Therefore, one form of the invention can be viewed as providing two mirror-image types of operation. At low engine speeds, such as at ground idle, the pressure within the sump chamber **3** is artificially reduced. That is, ordinarily, the pressure in that chamber **3** would be about 0.10 psig, pounds per square inch gauge. The invention reduces the pressure to about negative 0.5 psig, a negative value. The reduction is accomplished by the active withdrawal of air, caused by the eductor **50**. This lowering increases the air flowing across seals **24**, from the pressurization chamber **6** to the sump chamber **3**.

[0027] At high-power operation, such as at normal cruise engine speeds and above, the invention artificially restricts flow through vent **36**, because of the constriction **85**. This constriction will cause an increase in the pressure within sump chamber **3**, over that which would occur if the constriction **85** were absent.

[0028] Ordinarily, at cruise altitude, the pressure within the sump chamber **3** would be about 3.0 psig. The invention increases that pressure, by restricting flow through the eductor **50**, which has been added to the exit of sump vent **36**.

[0029] Stating the latter in a different way, if the constriction **85** in the eductor were not present, then, under the conditions just described, flow through vent **36** would have

a value of, say, X pounds per second. Under one form of the invention, that flow is now limited to 85 percent of X.

[0030] One embodiment of the invention was adapted to a pre-existing engine, which was designed with vents **36** of a relatively low cross section. Because of the low cross section, the relatively high percentage of 85 as just stated was required. Nevertheless, an engine can be re-designed so that the cross-section of vent **36** is larger. In such a case, the required pressure differential can be attained with a lower mass flow than 85, including a flow in the range of 70 percent, or less.

[0031] FIG. 3 is a flow chart illustrating processes undertaken by one form of the invention. Block **100** indicates that an eductor is maintained in association with a vent from an oil sump in a gas turbine engine. Eductor **50** in FIG. 2 provides an example of one such eductor. Block **105** in FIG. 3 indicates that eductor supply pressure is sensed, and block **110** indicates that, when pressure falls below a minimum, airflow through vent **36** is increased, by opening valve **63**, thereby driving the eductor **50** into operation.

[0032] Block **115** indicates that, at high-power operation, such as cruise operation in an aircraft, the airflow through the vent is restricted below the amount which would ordinarily occur. Block **110** is inoperative at this time: valve **63** is closed and the eductor **50** is turned off.

[0033] The discussion above focuses on pressure: the pressure sensor **60** in FIG. 2 is used to turn the eductor **50** on and off. The eductor **50**, when in operation, lowers pressure at region **58**.

[0034] However, another view of the invention can focus on airflow. The pressure differential indicated by sensor **60** provides a measure of amount of airflow across seals **24**. Lowering pressure at region **58** serves to increase that airflow.

[0035] In one mode of overall operation, blocks **105** and **110** in FIG. 3 can be characterized as maintaining airflow leaking into the sump chamber **3** through seals **24** at a predetermined minimum level.

[0036] A significant feature will be explained. FIG. 1 illustrates normal flow through vent **36**. The invention artificially alters that flow at high-power, or cruise, operation, by means of constriction **85**. The flow is artificially reduced.

[0037] Also, the normal flow through vent **36** in FIG. 1 creates a normal pressure in sump **3** at idle. The invention artificially reduces that pressure by means of eductor **50**, thereby increasing the leakage across seals **24**.

[0038] FIG. 4 illustrates one form of the invention. A generic gas turbine engine **200** is mounted in a nacelle **205** of an aircraft **210**. Block **215** represents the apparatus represented in FIG. 2. A compressor bleed **220** in FIG. 4 delivers pressurized air to the valve **60** in FIG. 2 which drives eductor **50** of FIG. 2, not separately shown in FIG. 4.

[0039] From one perspective, the invention measures a parameter from which flow through the vent **36** can be computed. That is, by the continuity principle, all, or nearly all, of the flow across seals **24** in FIG. 2 must exit through the vent **36**. Measuring the pressure differential across the

seals **24**, which indicates the amount of the flow across seals **24**, allows one to also estimate the amount of flow through the vent **36**.

[**0040**] The invention thus, in effect, determines whether the flow across the seals, unassisted by the eductor **50**, would lie above a required minimum. If not, the invention activates the eductor **50** to maintain the flow above the minimum. Conversely, if the measured parameter indicates that the unassisted flow would fall above a certain value, the invention de-activates the eductor **50**, because it is not needed.

[**0041**] In addition, it could be said that, based on Bernoulli's Law, ordinary flow through the vent **36** causes a drop in static pressure at the exit of the vent, at region **58** in **FIG. 2**. That is, in theory, the flow itself causes a reduction in exit pressure. The invention further lowers that pressure, by means of the eductor.

[**0042**] Numerous substitutions and modifications can be undertaken without departing from the true spirit and scope of the invention. What is desired to be secured by Letters Patent is the invention as defined in the following claims.

1. A method of operating a gas turbine engine having a lubrication sump which vents air through a vent which produces an exit pressure at the exit of the vent, comprising:

- a) running the engine at idle; and
- b) reducing said exit pressure.

2. Method according to claim 1, wherein the reducing of paragraph (b) comprises ducting a compressor discharge bleed to an eductor connected to the vent, to thereby draw air through the vent.

3. Method according to claim 11, and further comprising

- c) terminating the reducing of paragraph (b) when flow through the vent exceeds a floor.

4. Method according to claim 1, and further comprising:

- c) raising speed of the engine; and
- d) terminating the reducing of paragraph (b).

5. Method, comprising:

- a) ascertaining amount of airflow across seals which seal a lubrication sump; and
- b) maintaining said airflow above a predetermined minimum.

6. Method according to claim 5, wherein said airflow is maintained above said minimum by activating an eductor which draws air from the sump.

7. Method according to claim 5, wherein the sump is contained in a gas turbine engine.

8. Method according to claim 5, and further comprising the step of

- c) recovering oil scavenged from the sump and delivering the oil recovered to a bearing in a gas turbine engine.

9. Method, comprising:

- a) in a gas turbine engine, maintaining an eductor in fluid communication with a vent of a lubrication sump; and
- b) using the eductor to maintain fluid flow through the vent above a predetermined minimum.

10. Method according to claim 9, wherein the operation of paragraph (b) occurs at idle speeds.

11. Method according to claim 9, and further comprising:

- c) measuring a parameter which makes an indication of air flow which would exist in the vent without the eductor and, if the indication exceeds a floor, de-activating the eductor.

12. Method of operating a gas turbine engine, comprising:

- a) maintaining an eductor, having a flow restrictor therein, in fluid communication with a vent of a lubrication sump;
- b) when engine speed is below a floor, injecting a jet of air into the eductor, to increase flow through the vent, to decrease pressure in the sump; and
- c) when engine speed is above a threshold,
 - i) terminating the jet of air, and
 - ii) utilizing the flow restrictor to limit flow through the vent.

13. Apparatus, comprising:

- a) a gas turbine engine;
- b) a lubrication sump in the engine which vents air to an exit; and
- b) first means for increasing flow through the vent above normal during idle operation.

14. Apparatus according to claim 13, and further comprising:

- c) second means for de-activating the first means at high-power operation of the engine.

15. Apparatus according to claim 14, and further comprising:

- d) means for restricting flow to a level below normal at said high-power operation.

16. Apparatus, comprising:

- a) a gas turbine engine;
- b) a lubrication sump in the engine having a vent;
- c) a pressurization chamber for pressurizing the sump;
- d) an eductor in fluid communication with the vent;
- e) means for tapping pressurized air from a compressor in the engine and delivering the pressurized air to the eductor;
- f) valve means for activating and de-activating delivery of pressurized air to the eductor; and
- g) a pressure sensor for ascertaining whether pressure in the pressurization chamber falls below that in the sump by a predetermined amount and, if so, causing the valve means to deliver pressurized air to the eductor, to thereby reduce pressure in the sump.

17. Apparatus according to claim 16, wherein the eductor comprises a flow restrictor, which restricts flow through the vent when the eductor is not activated.

18. A method of operating an oil sump having a vent in a gas turbine aircraft engine, comprising:

- a) artificially reducing pressure in the sump during idle operation; and
- b) artificially reducing flow through the vent during cruise operation.

19. Apparatus for operating an oil sump having a vent in a gas turbine aircraft engine, comprising:

a) means for artificially reducing pressure in the sump during idle operation; and

b) means for artificially reducing flow through the vent during cruise operation.

* * * * *