

(19) World Intellectual Property Organization
International Bureau



(43) International Publication Date
31 January 2002 (31.01.2002)

PCT

(10) International Publication Number
WO 02/08385 A1

(51) International Patent Classification⁷: **C12N 1/20**

(21) International Application Number: PCT/KR01/00583

(22) International Filing Date: 7 April 2001 (07.04.2001)

(25) Filing Language: Korean

(26) Publication Language: English

(30) Priority Data:

2000/42271	22 July 2000 (22.07.2000)	KR
2000/42272	22 July 2000 (22.07.2000)	KR
2000/42273	22 July 2000 (22.07.2000)	KR

(71) Applicant (for all designated States except US): **IN-BIONET CORPORATION** [KR/KR]; 461-6 Jonmin-dong, Yusong-ku, Taejon 305-390 (KR).

[KR/KR]; 202, 458-8 Jonmin-dong, Yusong-ku, Taejon 305-390 (KR). **LEE, Mi-Kyoung** [KR/KR]; 306, Wunha Mansion, Misu-dong, Tongyeong 650-080 (KR). **KANG, Key-Jung** [KR/KR]; 415-1 Busa-dong, Jung-ku, Taejon 301-030 (KR). **SHIN, Chul-Soo** [KR/KR]; 113-1101, Samsung-Pureun Apt., Jonmin-dong, Yusong-ku, Taejon 305-390 (KR). **YUN, Jeong-Hwan** [KR/KR]; 105-1302, Dungji Apt., Dunsan 2-dong, Seo-ku, Taejon 302-122 (KR). **YUM, Do-Young** [KR/KR]; 405-1004, Expo Apt., Jonmin-dong, Yusong-ku, Taejon 305-390 (KR). **LEE, Jung-Ki** [KR/KR]; 407-504, Expo Apt., Jonmin-dong, Yusong-ku, Taejon 305-390 (KR). **PARK, Kee-Don** [KR/KR]; 109-1706, Cheonggu-Narae Apt., Jonmin-dong, Yusong-ku, Taejon 305-503 (KR). **CHOI, Ho-Joon** [KR/KR]; 103-406, Sejong Apt., Jonmin-dong, Yusong-ku, Taejon 305-390 (KR). **KOO, Bon-Tag** [KR/KR]; 5-401, Sindonga Apt., Yongjeon-dong, Dong-ku, Taejon 300-200 (KR).

(72) Inventors; and

(75) Inventors/Applicants (for US only): **LEE, Daesang**

(74) Agent: **KIM, Won-Joon**; 305, Soohyup Bldg, 917, Dunsan-dong, Seo-ku, Taejon 302-828 (KR).

[Continued on next page]

(54) Title: NOVEL STRAIN FOR DECOMPOSING TMAH, AND METHOD OF WASTEWATER TREATMENT USING THE SAME

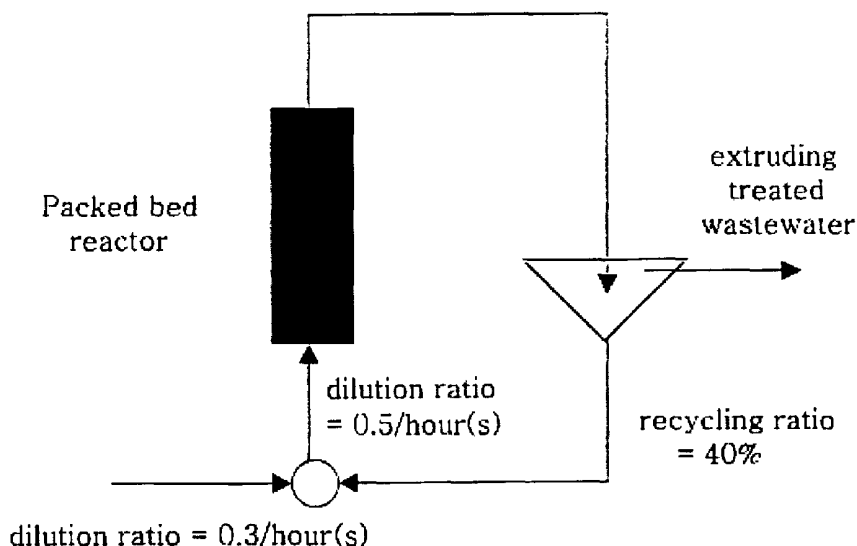

(57) Abstract: The present invention describes a wastewater treatment method by a microorganism decomposing Tetramethyl Ammonium Hydroxide (TMAH) which, utilized in etching the surface of silicone chip in semiconductor manufacturing process, is toxic and hard to decomposed. The present invention provides novel microorganisms capable of decomposing TMAH. Also, the present invention provides a treatment method for wastewater containing TMAH, using the microorganisms. The present invention is useful in industrial field as an environmental friendly wastewater treatment method by decomposing over 90 % of TMAH, one of environmental contamination materials in the wastewater of semiconductor factory.



WO 02/08385 A1



(81) Designated States (national): AE, AG, AL, AM, AT, AU, AZ, BA, BB, BG, BR, BY, BZ, CA, CH, CN, CR, CU, CZ, DE, DK, DM, DZ, EE, ES, FI, GB, GD, GE, GH, GM, HR, HU, ID, IL, IN, IS, JP, KE, KG, KP, KR, KZ, LC, LK, LR, LS, LT, LU, LV, MA, MD, MG, MK, MN, MW, MX, MZ, NO, NZ, PL, PT, RO, RU, SD, SE, SG, SI, SK, SL, TJ, TM, TR, TT, TZ, UA, UG, US, UZ, VN, YU, ZA, ZW.

(84) Designated States (regional): ARIPO patent (GH, GM, KE, LS, MW, MZ, SD, SL, SZ, TZ, UG, ZW), Eurasian patent (AM, AZ, BY, KG, KZ, MD, RU, TJ, TM), European patent (AT, BE, CH, CY, DE, DK, ES, FI, FR, GB, GR, IE,

IT, LU, MC, NL, PT, SE, TR), OAPI patent (BF, BJ, CF, CG, CI, CM, GA, GN, GW, ML, MR, NE, SN, TD, TG).

Published:

- with international search report
- with sequence listing part of description published separately in electronic form and available upon request from the International Bureau

For two-letter codes and other abbreviations, refer to the "Guidance Notes on Codes and Abbreviations" appearing at the beginning of each regular issue of the PCT Gazette.

NOVEL STRAIN FOR DECOMPOSING TMAH, AND METHOD OF
WASTEWATER TREATMENT USING THE SAME

5 TECHNICAL FIELD

The present invention relates to novel microorganism strains decomposing tetramethyl ammonium hydroxide; TMAH) and wastewater treatment method by
10 applying the above strains.

More particularly, the present invention relates to novel strains decomposing tetramethyl ammonium hydroxide which is utilized for etching the surface of silicon chip while manufacturing
15 semiconductors and is toxic and hard to be degraded. In addition, the present invention relates to wastewater treatment method which comprises applying the above strains into TMAH - containing wastewater and then performing batch culture or various kinds of
20 continuous culture for purging the wastewater.

BACKGROUND ART

25 Recently, internet and information technology (IT) industries have been developed and the

semiconductor demand also increased explosively. However, the development of the semiconductor industry induces the use of chemical substance gradually. Precisely, tetramethyl ammonium hydroxide (TMAH) which
5 is utilized for etching the surface of silicone chip while manufacturing semiconductors has been exhausted in increased amounts.

TMAH is very toxic (toxicity $LC_{50} = 460$ ppm) and cannot be biodegraded easily. Hence, TMAH makes
10 biological oxygen demand (BOD) fluctuate extremely in the wastewater treatment facilities of semiconductor manufacturing plant. Therefore, the removal of TMAH from industrial wastewater has become a very important issue in order to protect environment.

15 Presently, some treatment method has been disclosed for eliminating TMAH from wastewater. In detail, concentration method that comprises concentrating TMAH from the wastewater by using ion exchange resin column, ultra filtration (UF) or
20 reverse osmosis (RO), and disposing TMAH, has been reported. In addition, super-critical treatment method that comprises burning the concentrated TMAH has been demonstrated. Unfortunately, such traditional treatment methods require complicated processes and
25 provokes secondary contamination problems accompanied the said concentration or combustion.

Therefore, more economical and efficient processes for treating TMAH should be developed in order to satisfy the increasing need of environment protection.

5

To overcome the foregoing and other disadvantages, we, the inventors of the present invention, have developed biological treatment processes which can decompose and eliminate TMAH efficiently even in mild conditions. First, novel microorganism strains which were insensitive to TMAH and utilized TMAH as a sole carbon and energy source have been separated. In addition, we have confirmed that the above strains could reduce the biological oxygen demand (BOD) remarkably when the strains is applied to wastewater containing TMAH.

10
15

DISCLOSURE OF INVENTION

20

The object of the present invention is to provide novel microorganism strains that can degrade tetramethyl ammonium hydroxide (TMAH).

Further object of the present invention is to provide biological treatment methods for TMAH containing wastewater by applying the said strains.

25

The present invention provides novel microorganism strains capable of decomposing tetramethyl ammonium hydroxide (TMAH), which is often
5 utilized in etching the surface of silicone chip and, is toxic and hard to be degraded. In addition, the present invention provides TMAH containing wastewater treatment methods using the above strains.

10 The microorganism strains of the present invention is separated and identified by the process comprising steps as follows.

Wastewater sample is obtained from the domestic factory manufacturing semiconductors and is inoculated
15 into the nutrient culture medium for enriching the microorganism of said wastewater primarily. Then, the strains grown above are again cultivated on the Nutrient culture medium containing TMAH. 7 strains out of the above are separated according to the cell
20 survival, namely insensibility to TMAH. In particular, 7 TMAH insensitive strains are first separated and then designated with IBN-H1 ~ IBN-H7 respectively. Furthermore, three strains, IBN-H1, IBN-H4, IBN-H7 superior in decomposing TMAH, are selected among the
25 above strains.

The 3 adopted strains, IBN-H1, IBN-H4, IBN-H7,

are examined by BIOLOG system, MIDI, partial nucleotide sequence determination of 16s RNA and so on. As a result, the above strains are identified to be novel strains corresponding to *Kluyveromyces delphensis*, *Bacillus cereus* and *Acinetobacter sp.* 5 respectively. The strains obtained above are named with *Kluyveromyces delphensis* IBN-H1, *Bacillus cereus* IBN-H4 and *Acinetobacter sp.* IBN-H7 respectively and have been deposited in the Korean Collection for Type 10 Cultures (KCTC) of the Korean Research Institute of Bioscience and Biotechnology (KRIBB), an international deposit organization, #52, Oun-dong, Yusong-ku, Taejon 305-333, Republic of Korea on July 18, 2000, and identified as KCTC accession numbers, KCTC 0834 BP, 15 KCTC 0835 BP and KCTC 0836 BP.

It is confirmed that all the strains selected above can grow up to the OD value of 0.2 in the minimal culture medium containing TMAH as a sole 20 carbon source and essential mineral components. In addition, the strains can also grow in both 25°C and 30°C without variations and can grow well even in normal or weakly acidic condition.

25 The microorganism strains of the present invention are insensitive to TMAH and uses TMAH as a

sole carbon source for cell growth. Hence, they are exploited in the biological wastewater treatment method for removing TMAH. In this process, one strain or more than one strains selected among the group comprising
5 *Kluyveromyces delphensis*, *Bacillus cereus* and *Acinetobacter sp.* can be utilized in sole or mixed culture state, preferably.

The biological wastewater treatment process for
10 removing TMAH of wastewater, which utilizes the microorganism strain of the present invention, can be performed by using the batch culture process. Preferably, the wastewater treatment process is performed by the fed-batch culture or the continuous
15 culture for the efficiency and the continuation of the above process. In the continuous culture system, the microorganism strain is inoculated into a fermentation vessel containing the Nutrient culture medium and is cultivated by using the batch culture process until the
20 density reaches certain point. For example, the OD value is above 0.15. Then wastewater containing TMAH become passed through at the definite dilution velocity.

In the mean time, whatever culture process is adopted, the above stains can be fixed onto a
25 supporting carrier preferably. The carrier facilitates said processes since it enables the strains to be used

repeatedly and to remove wastewater conveniently. The carrier substance can be selected preferably among alginate, urethane foam and so on, which are conventional material for the microorganism fixation.

5

BRIEF DESCRIPTION OF THE DRAWINGS

FIG. 1 shows the survival density of the strains of the present invention according to the TMAH concentration;

10

FIG. 2a shows the growth curves of IBN-H1 strain according to cell incubation temperature;

15

FIG. 2b shows the growth curves of IBN-H4 strain according to incubation temperature;

FIG. 2c shows the growth curves of IBN-H7 strain according to incubation temperature;

20

FIG. 3a shows the growth curves of IBN-H1 strain according to culture pH;

FIG. 3b shows the growth curves of IBN-H4 strain according to culture pH;

25

FIG. 3c shows the growth curves of IBN-H7 strain according to culture pH;

FIG. 4 shows the batch-cultured growth curves of the strains of the present invention;

FIG. 5 shows the continuous-cultured growth curves of the IBN-H1 strain of the present invention;

FIG. 6 shows the diagram of the recycling equipment for continuous wastewater treatment of the present invention;

FIG. 7 shows the growth curves of the strains according to wastewater treatment by using the recycling equipment disclosed in **FIG. 6**;

FIG. 8 shows the diagram of the wastewater treatment equipment that exploits the packed bed reactor of the present invention;

FIG. 9a shows the schematic diagram of the pilot system that represents the biological treatment process of TMAH by applying the microorganism strains of the present invention;

FIG. 9b shows the detailed diagram of pilot system that represents the biological treatment process of TMAH by applying the strains of the present invention; and,

5

FIG. 10 shows the cell concentration as a function of the inlet TMAH concentration in the pilot system.

10 BEST MODE FOR CARRYING OUT THE INVENTION

Practically and presently preferred embodiments of the present invention are illustrative as shown below.

15 However, it will be appreciated that those skilled in the art, on consideration of this disclosure, may make modifications and improvements within the scope of the present invention.

20 Preferred Embodiment 1: Separation of microorganism strains insensitive to TMAH

(1) Proliferation of cell strains existed in wastewater of semiconductor factory

25

Wastewater samples, such as influent, mixed water

and return sludge were obtained from the wastewater treatment process of domestic semiconductor manufacturing companies.

The samples prepared above were diluted successively and smeared onto the Nutrient agar plate including sufficient carbon sources (beef extract 0.3% (DIFCO), peptone 0.5% (DIFCO), agar 1.5% (DIFCO)). Then the plate was cultivated with incubator at 30°C for 18 hours.

10

(2) Separation of TMAH insensitive strains

In order to separate the strains of the present invention, the insensibility to TMAH was examined in all the strains obtained from the above proliferation stage.

The Nutrient culture medium including sufficient carbon sources (beef extract 0.3% (DIFCO); peptone 0.5% (DIFCO)) was prepared, in which TMAH concentration was adjusted to 0.25%, 0.5%, 1.0% and 2.0% respectively. Then the strains proliferated above were inoculated and were cultivated with incubator at 30°C by shaking at 250 rpm velocity.

By the process described above, the 7 strains which proliferated and were distinguished with naked eyes were selected from the culture medium. The 7

strains were named with IBN-H1 ~ IBN-H7 respectively. Then the final culture medium solutions obtained above were suspended with the successive dilution method and were smeared onto the above Nutrient agar plate. In addition, the total cell number was represented as colony forming unit (CFU) appearing from 1 ml of culture medium (see Fig. 1).

As depicted in Fig. 1, all the 7 strains selected from the above process have seldom grown in the medium condition containing more than 1.7% of TMAH. In particular, the IBN-H3, IBN-H4, IBN-H5 and IBN-H7 strains can proliferate actively at the concentration less than the above.

Preferred Embodiment 2: Examination of TMAH decomposition ratio by the TMAH insensitive strains separated above

The TMAH decomposition ratio by the TMAH insensitive strains selected in Preferred Embodiment 1 was measured as follows.

The minimal culture medium including essential mineral components for cell growth ((NH₄)₂SO₄ 3g/L, trace element (H₃BO₃ 0.3g, CoSO₄ • 7H₂O 0.2g, ZnSO₄ • H₂O 0.1 g, MnCl₂ • H₂O 0.03 g, NaMoO₄ • H₂O 0.03 g, NiCl₂ • H₂O 0.02 g, CuSO₄ • H₂O 0.01 g, FeSO₄ • H₂O 20 g, CaCl₄ •

H₂O 10 g/L) 2 ml/L, MgSO₄ • 7H₂O (40%) 2 ml/L, 1 M of phosphate salt buffer solution (pH 7)) was mixed with 1% TMAH as a carbon source. Then the strains of the present invention were cultivated with the above
 5 culture medium by shaking at 30°C for 72 hours.

The BOD of the final culture medium was measured by performing triple tests. As a result, the removal ratio of TMAH was confirmed to be more than 90% in the IBN-H1, IBN-H4, IBN-H6 and IBN-H7 strains (see **Table 1**).

10

<Table 1>

Removal ratio of TMAH in the strains of the present invention

TAG	TMAH conc. before dilution	TMAH conc. after 10 ⁻² dilution	expected BOD	BOD				removal ratio
				sample	DO ₀	DO ₅	BOD ₅	
IBN-H1	1%	100 ppm	180→ 150~50	10	9.1	8.75	10.5	94.2%
IBN-H2	1%	100 ppm	180→ 150~50	10	9.15	6.55	78	56.7%
IBN-H3	1%	100 ppm	180→ 150~50	10	9.2	6.45	82.5	54.2%
IBN-H4	1%	100 ppm	180→ 150~50	10	9.2	9.05	4.5	97.5%
IBN-H5	1%	100 ppm	180→ 150~50	10	9.15	6.2	88.5	50.8%
IBN-H6	1%	100 ppm	180→ 150~50	10	9.15	8.65	15	91.7%
IBN-H7	1%	100 ppm	180→ 150~50	10	9.2	9.05	4.5	97.5%

15

Preferred Embodiment 3: Identification of the
microorganism strains with excellent activity in
decomposing TMAH

5 According to the processes of the Preferred
Embodiments 1 and 2, 3 kinds of strains, IBN-H1, IBN-H4
and IBN-H7, showing excellent activities in decomposing
TMAH were adopted. Then BIOLOG experiment, fatty acid
analysis, MIDI, 16S rRNA partial nucleotide sequencing
10 and so on were performed in order to identify the above
strains.

Above all, the morphological and biochemical
characteristics in the above strains of the present
invention were investigated. In detail, all the 3
15 strains of the present invention retained catalase
activity. And in Gram dyeing reaction for identifying
bacteria, the IBN-H4 strain was confirmed as gram
positive and the IBN-H7 strain was confirmed as gram
negative (See **Table 2**). On the other hand, the IBN-H1
20 strain was not applied for the Gram dyeing reaction
since it was an yeast.

<Table 2>

Morphological and biochemical properties in the strains
25 of the present invention

	IBN-H1	IBN-H4	IBN-H7
Mobility	no	no	no
Gram dyeing	-	positive	negative
Catalase activity	positive	positive	positive
Others	aerobic	aerobic	aerobic

In order to accomplish the BIOLOG analysis for identifying the IBN-H1 strain, the cell suspension of the above strain was inoculated onto 96-well microplate that carbon source of dried state was added into and was cultivated. Then the color variation and turbidity were recognized and analyzed by comparing the results with database which consisted in the results of more than 1,400 species of standard strains (aerobic strain, anaerobic strain and yeast strains). Consequently, the IBN-H1 strain was identified to belong to *Kluyveromyces delphensis* (See Table 3).

<Table 3>

Relationship of similar strains with IBN-H1 strain of the present invention

Similar strain	SIM	DIST	AVG	MAX
<i>Kluyveromyces delphensis</i>	0.623	5.288	0.569	1.094

<i>Candida glabrata</i>	0.026	6.338	0.500	1.487
<i>Pichia pastoris</i>	0.002	7.239	0.750	2.338
<i>Pichia amenthionina</i> var <i>pachy</i>	0.001	7.373	1.150	6.524
<i>Candida fluctus</i>	0.000	7.635	0.313	0.606
<i>Candida zeylanoides</i>	0.000	7.997	0.625	3.537
<i>Phodotorula hylophila</i>	0.000	8.119	2.399	9.845

The fatty acid contents of the IBN-H4 and IBN-H7 strains were analyzed as follows. In the IBN-H4 strain, fatty acids with carbon number 15 were the major component and in IBN-H7 strain fatty acids with carbon number 18 were the major component resultantly (See **Table 4**). As depicted in **Table 2**, in the fatty acids of the IBN-H4 strain having carbon number 15, 23.71% was iso type which had no double bond and 8.49% was anteiso type.

<**Table 4**>

Analysis of cellular fatty acids within the strains of the present invention

	IBN-H4	IBN-H7
C12:0		8.42
C12:0 2OH		2.12
C12:0 3OH		6.66

C12:0 iso	1.08	
C13:0 iso	7.48	
C13:0 anteiso	2.24	
C14:0 iso	6.26	
C14:0	2.28	1.82
C15:0 iso	23.71	
C15:0 anteiso	8.49	
C16:1 iso I/C 14:0 3OH	3.37	
C16:0 iso	9.40	
C16:1 w11c		
C15:0 iso 2OH/C 16:1 w7c	8.84	30.62
C16:0	6.72	14.31
C15:0 iso 3OH		
Iso C17:1 w10c	1.76	
Iso C17:1 w5c	3.87	
C17:0 iso		
C17:0 anteiso A	1.61	
C17:0 iso	9.02	
C17:0 anteiso	3.03	
C18:1 w9c		32.94
C18:1 w7c	3.03	1.69

In order to examine the sequence homology, 16S RNA partial nucleotide sequence analysis was performed by using the strains of the present invention respectively (See Sequence List; sequence number 1 and sequence number 2). Consequently, the IBN-H4 strain was shown to have 100% homology with *Bacillus cereus* IAM 12605T (See Table 5) and the IBN-H7 strain had 94.95% homology with *Acinetobacter calcoaceticus* ATCC

23055T (See **Table 6**). Therefore, the IBN-H4 and IBN-H7 strain was confirmed to belong to respective *Bacillus cereus* and *Acinetobacter sp.*

5 <Table 5>

The analysis data of 16S rRNA homology in the IBN-H4 strain of the present invention

Strains	Homology (%)	No. of non-identical nucleotides / No. of total nucleotides
<i>Bacillus cereus</i> IAM 12605T	100.00	0/584
<i>Bacillus thuringiensis</i> IAM 12077T	99.49	3/584
<i>Bacillus mycoides</i> DSM 2048T	99.30	4/571
<i>Bacillus weihenstephanensis</i> DSM 11821T	99.13	5/573
<i>Bacillus pseudomycooides</i> DSM 12442T	98.63	8/584
<i>Bacillus atrophaeus</i> NCIB 12899T	92.55	41/550
<i>Bacillus megaterium</i> IAM 13418T	92.45	44/583
<i>Bacillus cohnii</i> DSM 6307T	92.44	44/582
<i>Bacillus halmapalus</i> DSM 8723T	92.41	44/580
<i>Bacillus subtilis</i> ATCC 6051T	92.08	46/581
<i>Alicyclobacillus acidoterrestris</i> DSM 3922T	91.83	47/575
<i>Bacillus amyloliquefaciens</i> ATCC 23350T	91.81	47/574
<i>Bacillus licheniformis</i> ATCC 14580T	91.57	49/581
<i>Bacillus sporothermodurans</i> DSM 10599T	91.44	50/584
<i>Bacillus simplex</i> DSM 1321T	91.21	51/580
<i>Bacillus azotoformans</i> ATCC 29788T	91.12	49/552
<i>Bacillus psychrosaccharolyticus</i> ATCC 23296T	91.09	50/561
<i>Bacillus oleronius</i> DSM 9356T	91.08	52/583

<i>Bacillus pumilus</i> ATCC 7061T	90.01	51/567
<i>Bacillus circulans</i> ATCC 4513T	90.97	50/554
<i>Bacillus lentus</i> IAM 12466T	90.86	53/580
<i>Bacillus benzoovorans</i> ATCC 49005T	90.81	53/577
<i>Bacillus fastidiosus</i> DSM 91T	90.64	54/577
<i>Bacillus firmus</i> IAM 12464T	90.50	55/579
<i>Bacillus badius</i> ATCC 14574T	90.34	56/580
<i>Bacillus marinus</i> DSM 1297T	90.19	57/581

<Table 6>

The analysis data of 16S rRNA homology in the IBN-H7
5 strain of the present invention

Strains	Homology (%)	No. of non-identical nucleotides / No. of total nucleotides
<i>Acinetobacter calcoaceticus</i> ATCC 23055T	94.95	26/515
<i>Acinetobacter haemolyticus</i> DSM 6962T	94.17	30/515
<i>Acinetobacter baumannii</i> DSM 30007T	93.98	31/515
<i>Acinetobacter lwoffii</i> DSM 2403T	92.82	37/515
<i>Acinetobacter radioresistens</i> DSM 6976T	92.77	37/512
<i>Acinetobacter johnsonii</i> DSM 6963T	92.23	40/515
<i>Acinetobacter junii</i> DSM 6964T	91.47	44/516

Preferred Embodiment 4: TMAH availability in the identified strains of the present invention

10

The IBN-H1, IBN-H4 and IBN-H7 strains of the

present invention identified above were examined in order to detect whether TMAH could be utilized as a sole carbon source.

The minimal culture medium including essential mineral components for cell growth (reference: Preferred Embodiment 2) was utilized and mixed with 0.5% TMAH as a carbon source. Then the above strains were inoculated independently and cultivated at 30°C for 72 hours by shaking. This culture medium was diluted successively and the diluted cell suspension was smeared onto the culture plate having the same composition of the above culture medium and incubated.

The 3 strains of the present invention were observed to form colonies onto the culture plate respectively, which confirmed that the above strains could grow by using TMAH as a sole carbon source and as an energy source.

In order to investigate the difference of the strains, the availability of TMAH was examined in the strains of the present invention and other strains related with the above stains.

In detail, *Kluyveromyces dephensis* and *Saccharomyces cerevisiae* were utilized instead of the IBN-H1 strain; *Bacillus cereus*, *Bacillus subtilis* and *Bacillus brevis* instead of the IBN-H4 strain; and

Acinetobacter calcoaceticus and *Acinetobacter* *genospecies* instead of the IBN-H7 strain respectively in order to disclose whether TMAH could be adopted as a carbon source or not.

5 Consequently, all the comparative strains having relationship with the strains of the present invention did not form colonies. Hence the comparative strains were confirmed not to utilize TMAH as a carbon source (See **Table 7**).

10 Therefore, the strains of the present invention were identified again to have different physiological and biochemical properties from those of conventional strains, although the strains of IBN-H1, IBN-H4 and IBN-H7 in the present invention belonged to
15 *Kluyveromyces delphensis*, *Bacillus cereus* and *Acinetobacter sp.* respectively.

<Table 7>

20 Examination for the usage of TMAH as a carbon source in the selected strains of the present invention and comparative strains related with the above strains

The stains of the present invention (comparative strains related)	Colony forming (yes/no)
<i>Kluyveromyces delphensis</i> IBN-E1	yes
(<i>Kluyveromyces delphensis</i>)	no
(<i>Saccharomyces cerevisiae</i>)	no

<i>Bacillus cereus</i> IBN-H4	yes
(<i>Bacillus cereus</i>)	no
(<i>Bacillus subtilis</i>)	no
(<i>Bacillus brevis</i>)	no
<i>Acinetobacter sp.</i> IBN-H7	yes
(<i>Acinetobacter calcoaceticus</i>)	no
(<i>Acinetobacter genospecies</i>)	no

Preferred Embodiment 5: TMAH insensibility of the identified strains

5

The IBN-H1, IBN-H4 and IBN-H7 strains of the present invention identified above were examined in order to detect the TMAH insensibility.

10 The cell strains of the present invention and the related strains were inoculated into the Nutrient culture medium (Bacto beef extract 3g/L, Bacto peptone 5g/L) with 3 ml volume respectively and were cultivated at 30°C for 18 hours by shaking. Then the culture medium of each strain was allotted to measure the
15 absorbance (OD) at 600 nm, which would adjust the density and number of the cell strains and could facilitate the insensibility experiments. The above samples were centrifuged at 12,000 rpm for 5 minutes and were washed 3 times with saline for eliminating the
20 remaining medium. Then the sample were resuspended by

adding 1 ml of 2% TMAH and maintained at 30°C for an hour. The cell strains were again centrifuged in order to remove the cell supernatant and washed 3 times with saline so as to remove the remaining TMAH. Then the
5 cell samples obtained were diluted with 200 µl of physiological saline successively and were resuspended. The cell suspensions were smeared onto the agar culture plate containing Nutrient medium components and were incubated at 30°C for 18 hours. And then the number of
10 colonies on the above agar plate was calculated in each strain.

For controlled samples, physiological saline was utilized instead of 2% TMAH in each cell strains. In addition, the number of colonies formed in each
15 experimental sample and comparative sample was adjusted reciprocally with that in the controlled sample, which had no TMAH for measuring exactly.

In order to compare the insensibility to TMAH,
20 both the strains of the present invention and the strains related with the above strains were investigated for the detection.

Precisely, as a comparative strain related with the IBN-H1 strain of the present invention
25 *Kluyveromyces dephensis* and *Saccharomyces cerevisiae* were applied; *Bacillus cereus*, *Bacillus subtilis* and

Bacillus brevis as a strain related with the IBN-H4 strain; and *Acinetobacter calcoaceticus* and *Acinetobacter genospecies* as a strain related with the IBN-H7 strain respectively.

5 Consequently, all the comparative strains having relationship with the strains of the present invention formed even smaller number of colonies than the strains of the present invention. Hence the comparative strains were confirmed to be much less insensitive to
10 TMAH (See **Table 8**).

 Therefore, the strains of the present invention, IBN-H1, IBN-H4 and IBN-H7, were also identified to be new strains having different physiochemical properties from those of conventional strains although the above
15 strains belonged to *Kluyveromyces delphensis*, *Bacillus cereus* and *Acinetobacter sp.* respectively.

 As demonstrated above, the above strains of the present invention, IBN-H1, IBN-H4 and IBN-H7, are
20 confirmed as new strains which have not been reported. The strains obtained above are named with *Kluyveromyces delphensis* IBN-H1, *Bacillus cereus* IBN-H4 and *Acinetobacter sp.* IBN-H7 respectively and have been deposited with the Korean Collection for Type
25 Cultures (KCTC) of the Korean Research Institute of Bioscience and Biotechnology (KRIBB), an international

deposit organization, #52, Oun-dong, Yusong-ku, Taejon 305-333, Republic of Korea on July 18, 2000, and identified as KCTC accession numbers, KCTC 0834 BP, KCTC 0835 BP and KCTC 0836 BP.

5

<Table 8>

Comparison of the insensibility to TMAH in the selected strains of the present invention and the related strains

10

The stains of the present invention (comparative strains related)	Insensibility to TMAH
<i>Kluyveromyces delphensis</i> IBN-H1	100%
(<i>Kluyveromyces delphensis</i>)	< 10 ± 5%
(<i>Saccharomyces cerevisiae</i>)	< 10 ± 5%
<i>Bacillus cereus</i> IBN-H4	100%
(<i>Bacillus cereus</i>)	< 10 ± 5%
(<i>Bacillus subtilis</i>)	< 10 ± 5%
(<i>Bacillus brevis</i>)	< 10 ± 5%
<i>Acinetobacter</i> sp. IBN-H7	100%
(<i>Acinetobacter calcoaceticus</i>)	< 10 ± 5%
(<i>Acinetobacter genospecies</i>)	< 10 ± 5%

Preferred Embodiment 6: Characteristics in cell growth
of the identified strains

- 5 (1) Characteristics of cell growth according to
 incubation temperature

 In order to detect the optimal temperature for
 cultivating the separated strains of the present
10 invention, the above strains were suspended by using
 the same culture medium with that used in Preferred
 Embodiment 2 and 200 μ l of the culture medium was added
 into 96-well microplate. Then the cell in the
 microplate was cultured at 25°C and 30°C for 72 hours
15 by shaking at 250 rpm. The OD values of the cell
 strains were calculated at 600 nm by using microplate
 reader (MR 5000, Dynatech, USA) (see **Fig. 2a**, **Fig. 2b**
 and **Fig. 2c**).

 As described in **Fig. 2a**, **Fig. 2b** and **Fig. 2c**, the
20 cell strains proliferated more actively at 30°C than at
 25°C during the whole culturing process. In addition,
 the cell numbers (OD value) were maintained almost
 constant through culturing period at each temperature,
 particularly about 0.2, 0.05 in the IBN-H1 strain,
25 about 0.15, 0.15 in the IBN-H4 strain and about 0.25,
 0.15 in the IBN-H7 strain.

(2) Characteristics of cell growth according to pH

In order to examine the optimal pH for culturing
5 the separated strains of the present invention, the
above strains was suspended by using the same culture
medium with that used in Preferred Embodiment 3 and 200
 μ l of the culture medium was added into 96-well
microplate. Then the cell in the microplate was
10 cultured at pH 5, pH 7 and pH 9, at 30°C for 72 hours
by shaking at 250 rpm. The OD values of the strains
were calculated at 600 nm by using microplate reader
(MR 5000, Dynatech, USA) (see **Fig. 3a**, **Fig. 3b** and **Fig.**
3c).

15 As described in **Fig. 3a**, **Fig. 3b** and **Fig. 3c**, in
the IBN-H1 strain, the OD value in PH 5 to PH 7 range
was about 0.2; in the IBN-H4 strain, the OD value at pH
7 ranges was about 0.15; and in the IBN-H7 strain, OD
value at pH 7 range was 0.2 approximately. Hence, the
20 above 3 strains were known to grow well in both the
normal and weakly acidic condition.

(3) Characteristics of cell growth in batch culture
by using culture medium containing 1% TMAH

25

In order to examine the growth pattern of the

above strains while performing batch culture by using TMAH - containing culture medium, the above strains IBN-H1, IBN-H4 and IBN-H7 were cultivated with the same culture medium of Preferred Embodiment 2 at 30°C for 72
5 hours by shaking at 250 rpm. The OD values of the above strains were calculated at 600 nm in every hour interval by using microplate reader (MR 5000, Dynatech, USA) and then the growth curves of the each cell strain were drawn (see **Fig. 4**).

10 Consequently as described in **Fig. 4**, the IBN-H1 and the IBN-H4 strains reached the maximum value of the cell growth (OD value: 2.24 and 1.80) after about 22-hour culture and the IBN-H7 strains increased the growth rate slowly until 100 hours and reached the
15 maximum value (OD value: 2.36).

Preferred Embodiment 7: Biological TMAH treatment process by using the strains of the present invention

20 The possibility of the above strains for biological treatment was investigated indirectly by applying the water treatment model for the TMAH - containing wastewater and then by monitoring the cell number of the strains in culture medium.

25 The volume of the fermentator was 5 L, if not mentioned especially, and the initial amount of the

culture medium was 3 L and the incubation temperature was 30°C.

(1) Enrichment of the strains for applying to the
5 treatment process

In order to make practical application for the TMAH - containing wastewater treatment, the cell strains obtained in the present invention were
10 cultivated with high density respectively.

The above strains were inoculated into the fermentation vessel with 5 L volume including 3L of Nutrient culture medium with glucose (glucose 10 g/L, yeast extract 10 g/L, $\text{MgSO}_4 \cdot 7\text{H}_2\text{O}$ 1.2g/L, KH_2PO_4 13.3
15 g/L, $(\text{NH}_4)_2 \cdot \text{HPO}_4$ 4 g/L, pH 7.0 (HCl)) independently and were cultivated at 30°C. In every 24-hour interval, high Nutrient culture medium (glucose 274 g/L, yeast extract 211 g/L, $\text{MgSO}_4 \cdot 7\text{H}_2\text{O}$ 1 g/L, $(\text{NH}_4)_2 \cdot \text{HPO}_4$ 1.5 g/L, pH 7.0 (HCl)) was added again by 100 ml volume.
20 According to the process, the fed-batch culture was accomplished.

Consequently, all the 3 strains of the present invention sustained the high density which was more than 40 in the OD value. Hence, it was confirmed that
25 the above strains could multiply so as to be applied for industrial uses.

(2) Batch culture treatment

The above strains, IBN-H1, IBN-H4 and IBN-H7 were
5 inoculated into the fermentation vessel with 5 L volume
including 3L of Nutrient culture medium (yeast extract
1 g/L, $\text{MgSO}_4 \cdot 7\text{H}_2\text{O}$ 0.8 g/L, KH_2PO_4 1 g/L, $(\text{NH}_4)_2 \cdot \text{HPO}_4$ 1
g/L, pH 7.0 (HCl)) with 1.0% TMAH independently and
were cultivated at 30°C for 70 hours in batch pattern.
10 As a result, the OD value at 660 nm reached 2.2, 1.8
and 2.5 respectively.

Consequently, all the 3 strains of the present
invention sustained the TMAH insensibility even in
large scale and can utilize TMAH as a sole carbon
15 source for cell growth. Hence, it was confirmed that
the above strains could be exploited to treat
wastewater containing TMAH in the batch culture pattern.

(3) Continuous culture treatment

20 The above strains, IBN-H1, IBN-H4 and IBN-H7 were
cultivated respectively by using the same treatment
process of the above batch culture. Then at the point
that the OD value reached to 2.2, 1.8 and 2.5
25 respectively, the TMAH - containing culture medium and
water were passed through with 0.15 of dilution ratio

per hour for treating continuously.

Consequently, the OD values have decreased from the start point of the continuous culture and were maintained stably after about 60 hours in near 1.1, 0.9
5 and 1.2 of the OD value respectively (See Fig. 5).

Therefore, it was confirmed that all the 3 strains of the present invention sustained considerable cell densities even in the continuous treatment process and could be exploited to treat TMAH - containing
10 wastewater in the continuous pattern.

In Preferred Embodiments described below, the above 3 strains of the present invention were cultivated with high densities and were mixed in the
15 same ratio's and then were applied for performing the experiments.

(4) Recycling continuous culture treatment

20 As shown in Fig. 6, the recycling type continuous culture was performed by the process as follows. Precisely, the culture medium outflowing from the continuous treatment process was passed through cell separation unit which was composed of fibrous strand;
25 and then recovered into the fermentation vessel.

At the initial stage, simple batch culture was

performed. But if the OD value reached 2.0, the culture pattern was changed to the recycling continuous culture. The dilution ratio was 0.3 per hour and the plain medium corresponding to 80% volume of the culture medium was extruding from the fermentator finally. Namely, the reflection rate was adjusted to 0.2.

Consequently, the OD value of the culture medium was maintained in 6 ~ 7 range stably and long when about 50 hours has passed from the initiation point (See Fig. 7).

Therefore, it was confirmed that the TMAH - containing wastewater could also be treated efficiently even by using the cell strains of the present invention and the recycling continuous culture process.

(5) Continuous culture treatment by using fluidized - bed reactor

According to the above process of continuous culture treatment, the cell strains were cultivated. If the OD value reached 0.2, conventional polyurethane foam (standard size; $0.5 \times 0.5 \times 0.5 \text{ cm}^3$) which has been used in fermentator was added with 90% of the void volume for the absorption of the above strains. The resulting support with the cell strains was incubated in the continuous culture pattern.

Consequently, the same cell density can be sustained with that obtained from the simple continuous culture process although the dilution ratio (0.3 per hour) was even higher than that of the above simple continuous culture (0.5 per hour).

(6) Continuous culture treatment by using packed bed reactor

The packed bed reactor (reactor standard = radius 10, height 30 cm; void volume = 70%) which was fulfilled with the polyurethane foam supporting the cell strains of the present invention was exploited. The culture medium and recycling water were passed upward in the dilution ratio 0.3/hour and 0.2/hour respectively through the above packed bed reactor and pressure (namely, dilution ratio 0.5/hour while using the reactor as a standard). 40% (volume ratio) of extruding water from the reactor was recovered and reused with recycling water (See Fig. 8).

Consequently, the OD value was maintained at 1.4 stably during 2 months and the biological oxygen demand (BOD) has reduced from 466.5 to 169.7, which corresponded to 74% reduction.

25

Preferred Embodiment 8: Pilot system experiment of biological TMAH treatment process by using the strains of the present invention

5 In order to treat wastewater containing TMAH, the pilot system was established in the semiconductor manufacturing factory (Hyundai Electronics Industries Co., Ltd; Chungju). The mixed strains composed of the novel strains of the present invention were applied for
10 performing the biological wastewater treatment.

 The cell recycle bioreactor having 200 L of volume capacity and 120 L of working capacity was used and a recycle filtration membrane (ceramic material, 0.1 μm of pore size) was adopted for preventing cells
15 from outflowing (See **Fig. 9a** and **Fig 9b**).

 Generally, the TMAH concentration in discharging wastewater from the factory was comparatively low in 3 ~ 4 g/L. Hence, the concentrated TMAH solution was added into the wastewater directly for the
20 convenience of the experiment. In detail, the TMAH concentration of the wastewater was adjusted to reach 5 ~ 15 g/L. By adding the concentrated TMAH solution to the outflowing wastewater in this Preferred Embodiment for the convenience. However, reverse
25 osmosis system (RO) would be exploited in the practical application in order to concentrate TMAH of

wastewater highly.

In addition, since the original wastewater contained excessive amount of TMAH relatively, the culture medium containing proper nitrogen sources (per
5 15 g TMAH: containing yeast extract 0.1 g, $(\text{NH}_4)_2\text{SO}_4$ 1 g, $\text{MgSO}_4 \cdot 7\text{H}_2\text{O}$ 0.05 g) should be mixed to make Nutrient state required for the cell growth.

At that time, temperature (25 ~ 40°C), air volume (1 vvm), pH (6.5 ~ 7.2) and so on was maintained
10 properly and flow rate of wastewater and retention period were adjusted to 30 L/hour and 4 hour respectively during the treatment, which helped the cell growth environmentally.

15 According to the reaction period and TMAH concentration of wastewater, the dried cell concentration was changed as demonstrated in **Fig. 10** and the results were summarized in **Table 9**. As shown in **Table 9**, it was confirmed that the TMAH wastewater
20 (5 ~ 15 g/L) having various concentrations was treated successfully (treatment efficiency 94 ~ 99%).

<Table 9>

Pilot experiment of biological TMAH treatment process
25 by using the strains of the present invention.

TMAH conc. of inflowing wastewater	BOD5 (ppm) of inflowing wastewater	BOD5 (ppm) of wastewater treated	Conc. of stable cell strains (g/L)	Treatment efficiency (%)
5	10,000	50~70	-	>99
8	16,000	400~600	24~25	96~97.5
12	24,000	1,000~400	36~37	94~95
15	30,000	400~600	43~44	>98

INDUSTRIAL APPLICABILITY

5 The present invention relates to novel strains decomposing tetramethyl ammonium hydroxide, which is often utilized in etching the surface of silicone chip while manufacturing semiconductors and is toxic and hard to be degraded. In addition, the present
10 invention relates to a wastewater treatment method which comprises cultivating the above strains by using batch culture processes; applying the culture medium into TMAH containing wastewater; and performing continuous culture processes.

15 The novel strains of the present invention and the wastewater treatment process can decompose environmental contaminants TMAH over 95% existed in the wastewater of the semiconductor manufacturing facilities. Therefore, the wastewater treatment

method of the present invention can be applied to industries as an environmental friendly wastewater treatment system efficiently.

- 5 Those skilled in the art will appreciate that the conceptions and specific embodiments disclosed in the foregoing description may be readily utilized as a basis for modifying or designing other embodiments for carrying out the same purposes of the present invention.
- 10 Those skilled in the art will also appreciate that such equivalent embodiments do not depart from the scope of the invention as set forth in the appended claims.

**INDICATIONS RELATING TO DEPOSITED MICROORGANISM
OR OTHER BIOLOGICAL MATERIAL**

(PCT Rule 13bis)

A. The indications made below relate to the deposited microorganism or other biological material referred to in the description on page <u>23</u> , line <u>22</u>	
B. IDENTIFICATION OF DEPOSIT Further deposits are identified on an additional sheet <input type="checkbox"/>	
Name of depositary institution Korean Collection for Type Culture (KCTC)	
Address of depositary institution <i>(including postal code and country)</i> Korean Research Institute of Bioscience and Biotechnology (KRIBB) #52, Oun-dong, Yusong-ku, Taejon 305-333, Republic of Korea	
Date of deposit July 18, 2000	Accession Number KCTC 0834BP
C. ADDITIONAL INDICATIONS <i>(leave blank if not applicable)</i> This information is continued on an additional sheet <input type="checkbox"/>	
(Blank area for additional indications)	
D. DESIGNATED STATES FOR WHICH INDICATIONS ARE MADE <i>(if the indications are not for all designated States)</i>	
(Blank area for designated states)	
E. SEPARATE FURNISHING OF INDICATIONS <i>(leave blank if not applicable)</i>	
The indications listed below will be submitted to the International Bureau later <i>(specify the general nature of the indications e.g., "Accession Number of Deposit")</i>	
(Blank area for separate indications)	

For receiving Office use only	
<input type="checkbox"/> This sheet was received with the international application	
Authorized officer <i>[Signature]</i>	

For International Bureau use only	
<input type="checkbox"/> This sheet was received by the International Bureau on:	
Authorized officer	

**INDICATIONS RELATING TO DEPOSITED MICROORGANISM
OR OTHER BIOLOGICAL MATERIAL**

(PCT Rule 13bis)

A. The indications made below relate to the deposited microorganism or other biological material referred to in the description on page <u>23</u> , line <u>22</u> .	
B. IDENTIFICATION OF DEPOSIT Further deposits are identified on an additional sheet <input type="checkbox"/>	
Name of depositary institution Korean Collection for Type Culture (KCTC)	
Address of depositary institution <i>(including postal code and country)</i> Korean Research Institute of Bioscience and Biotechnology (KRIBB) #52, Oun-dong, Yusong-ku, Taejon 305-333, Republic of Korea	
Date of deposit July 18, 2000	Accession Number KCTC 0835BP
C. ADDITIONAL INDICATIONS <i>(leave blank if not applicable)</i> This information is continued on an additional sheet <input type="checkbox"/>	
(Blank area for additional indications)	
D. DESIGNATED STATES FOR WHICH INDICATIONS ARE MADE <i>(if the indications are not for all designated States)</i>	
(Blank area for designated states)	
E. SEPARATE FURNISHING OF INDICATIONS <i>(leave blank if not applicable)</i>	
The indications listed below will be submitted to the International Bureau later <i>(specify the general nature of the indications e.g., "Accession Number of Deposit")</i>	
(Blank area for separate indications)	

For receiving Office use only	
<input type="checkbox"/> This sheet was received with the international application	
Authorized officer 	

For International Bureau use only	
<input type="checkbox"/> This sheet was received by the International Bureau on:	
Authorized officer	

**INDICATIONS RELATING TO DEPOSITED MICROORGANISM
OR OTHER BIOLOGICAL MATERIAL**

(PCT Rule 13bis)

A. The indications made below relate to the deposited microorganism or other biological material referred to in the description on page <u>23</u> , line <u>23</u>	
B. IDENTIFICATION OF DEPOSIT Further deposits are identified on an additional sheet <input type="checkbox"/>	
Name of depositary institution Korean Collection for Type Culture (KCTC)	
Address of depositary institution <i>(including postal code and country)</i> Korean Research Institute of Bioscience and Biotechnology (KRIBB) #52, Oun-dong, Yusong-ku, Taejon 305-333, Republic of Korea	
Date of deposit July 18, 2000	Accession Number KCTC 0836BP
C. ADDITIONAL INDICATIONS <i>(leave blank if not applicable)</i> This information is continued on an additional sheet <input type="checkbox"/>	
D. DESIGNATED STATES FOR WHICH INDICATIONS ARE MADE <i>(if the indications are not for all designated States)</i>	
E. SEPARATE FURNISHING OF INDICATIONS <i>(leave blank if not applicable)</i>	
The indications listed below will be submitted to the International Bureau later <i>(specify the general nature of the indications e.g., "Accession Number of Deposit")</i>	

For receiving Office use only	
<input type="checkbox"/> This sheet was received with the international application	
Authorized officer 	

For International Bureau use only	
<input type="checkbox"/> This sheet was received by the International Bureau on:	
Authorized officer	

What is claimed is:

1. *Kluyveromyces delphensis* IBN-H1 strain (accession number : KCTC 0834 BP) which is insensitive to tetramethyl ammonium hydroxide (TMAH) and uses TMAH as a carbon source for cell growth.
2. *Bacillus cereus* IBN-H4 strain (accession number : KCTC 0835 BP) which is insensitive to TMAH and uses TMAH as a carbon source for cell growth.
3. *Acinetobacter* sp. IBN-H7 strain (accession number : KCTC 0836 BP) which is insensitive to TMAH and uses TMAH as a carbon source for cell growth.
4. A biological wastewater treatment method for removing tetramethyl ammonium hydroxide of wastewater, which utilizes one strain or more than one strains selected among the group comprising *Kluyveromyces delphensis* of Claim 1, *Bacillus cereus* of Claim 2 and *Acinetobacter* sp. Of Claim 3.
5. The biological wastewater treatment method for removing tetramethyl ammonium hydroxide of wastewater according to Claim 4, in which

treatment is performed by batch culture.

5 6. The biological wastewater treatment method for removing tetramethyl ammonium hydroxide of wastewater according to Claim 4, in which treatment is performed by continuous culture.

10 7. The biological wastewater treatment method for removing tetramethyl ammonium hydroxide of wastewater according to Claim 6, in which the microorganism strain/strains is/are fixed onto a supporting carrier.

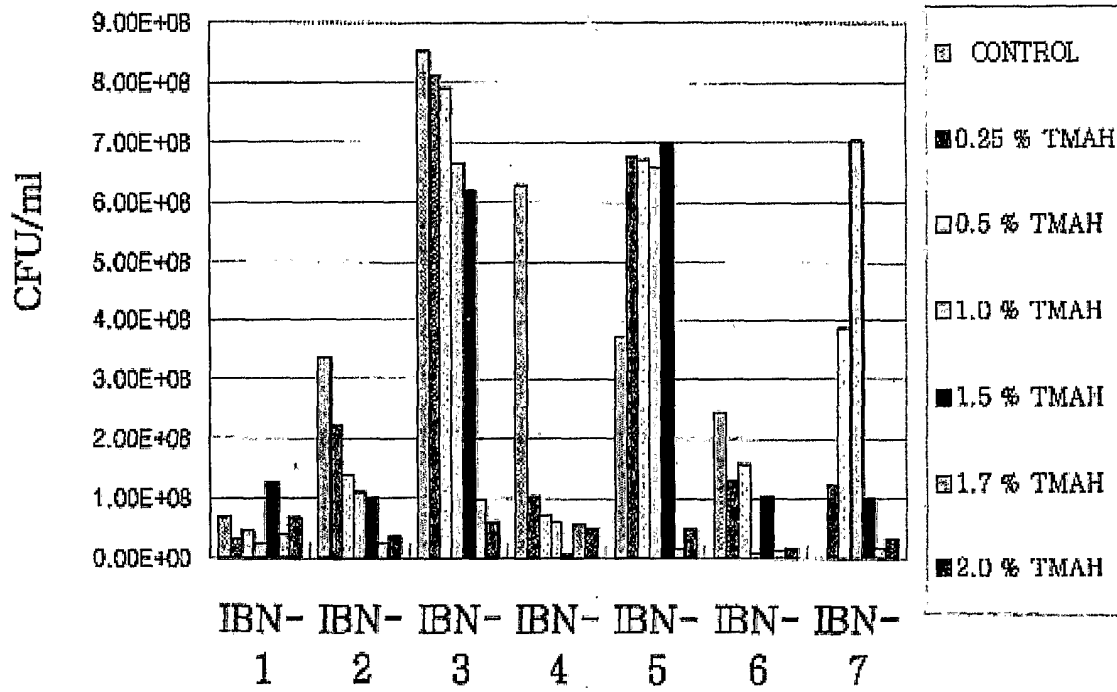

Fig. 1

2/15

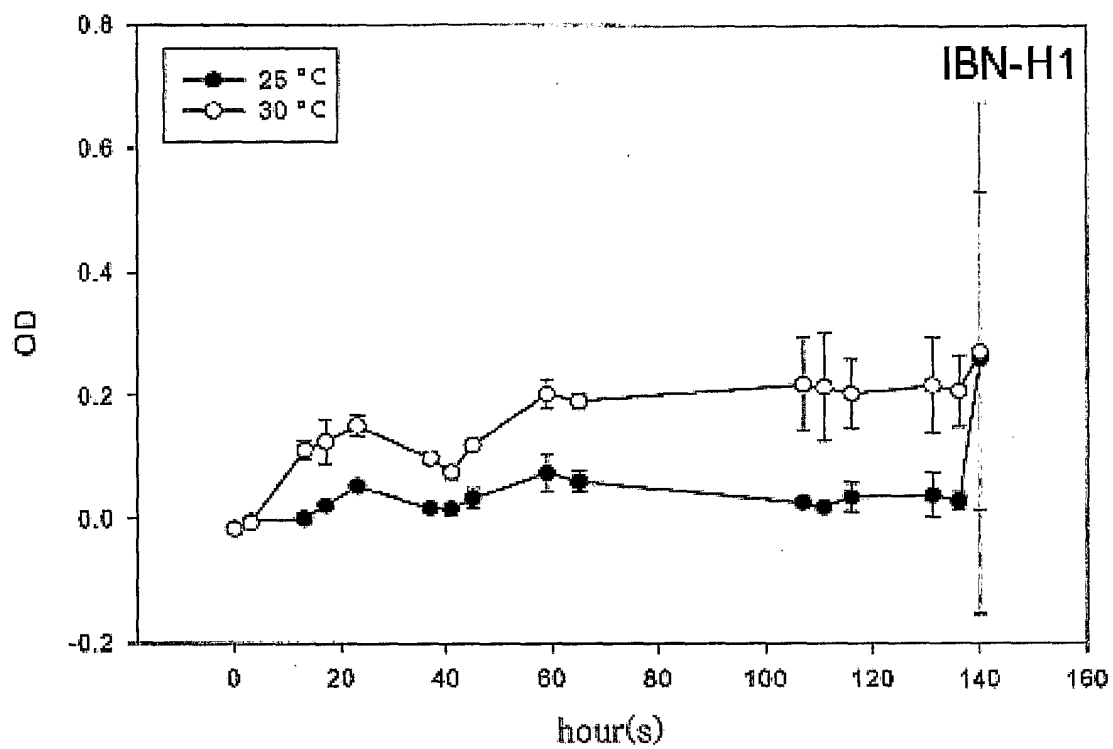

Fig. 2a

3/15

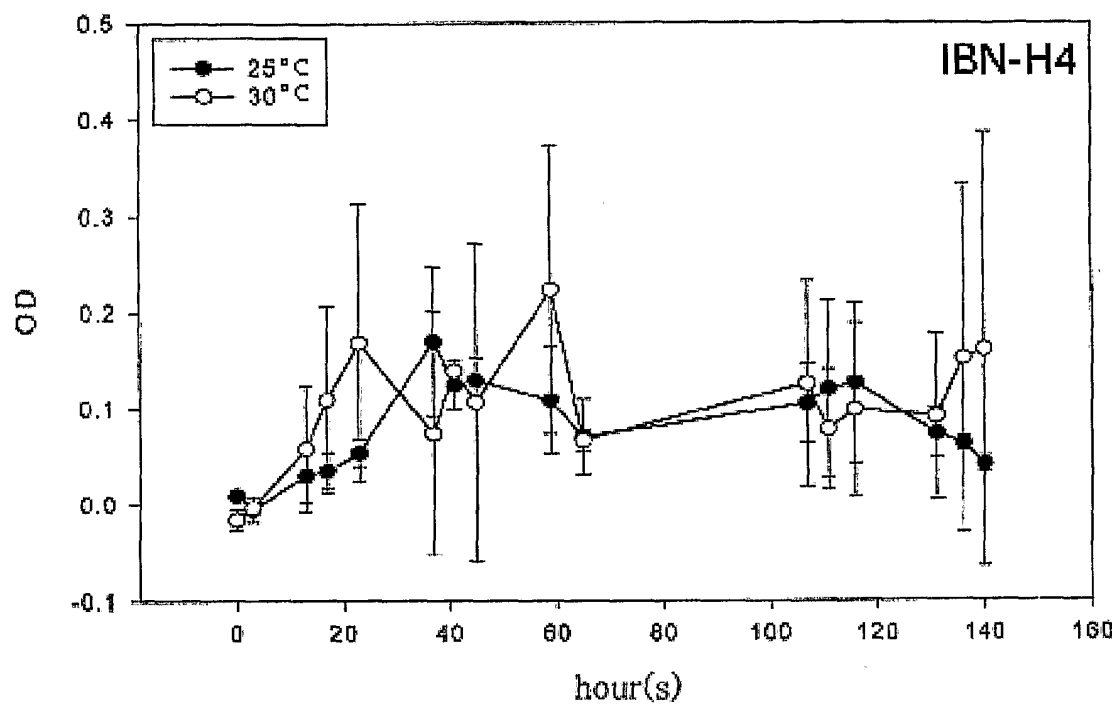

Fig. 2b

4/15

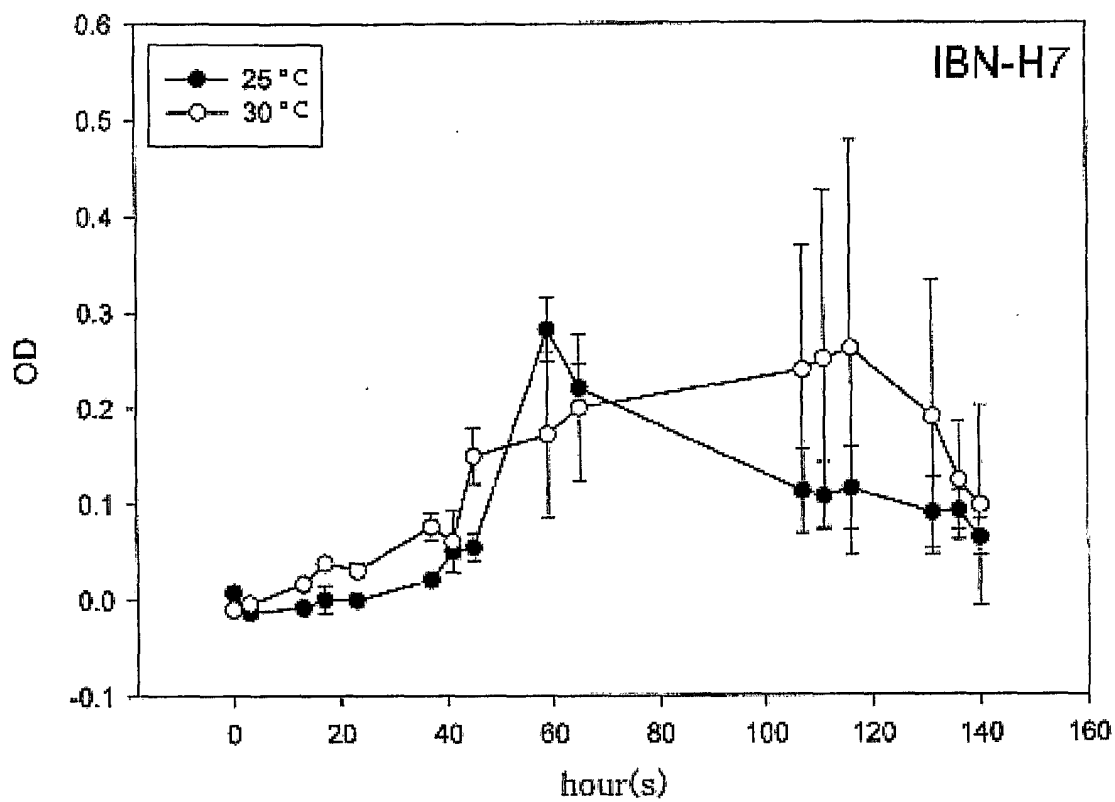

Fig. 2c

5/15

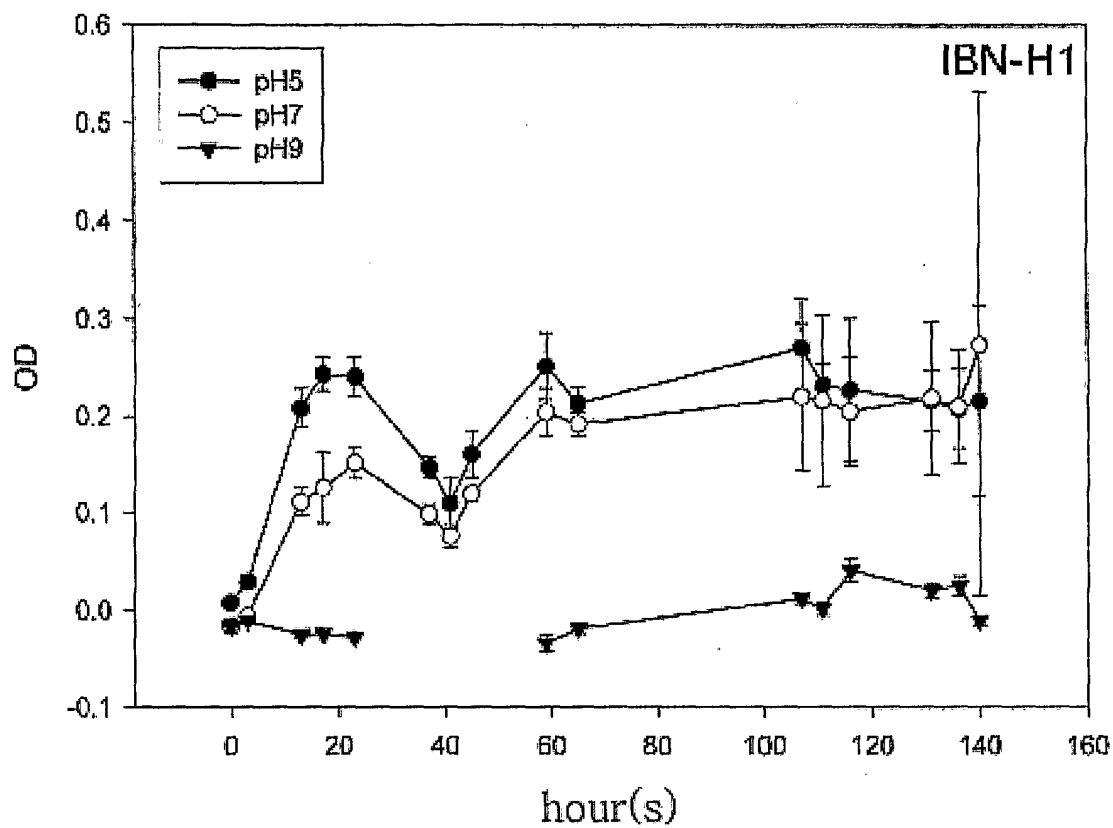

Fig. 3a

6/15

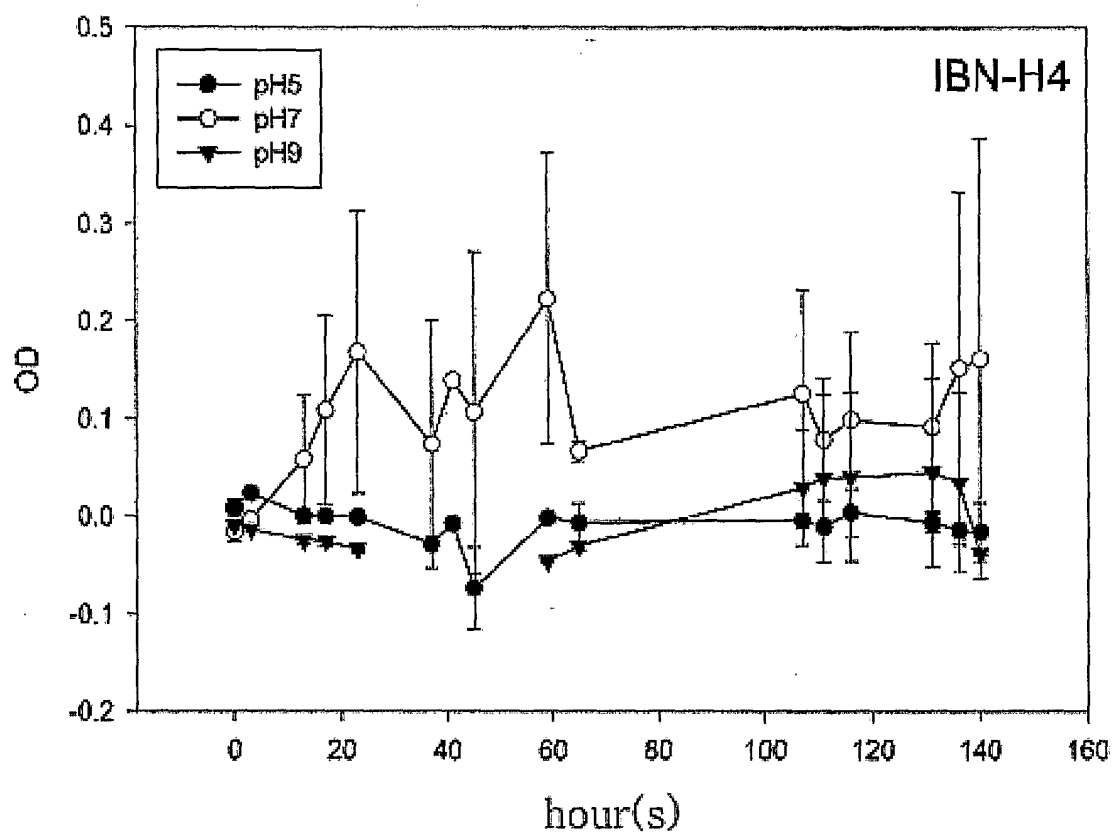

Fig. 3b

7/15

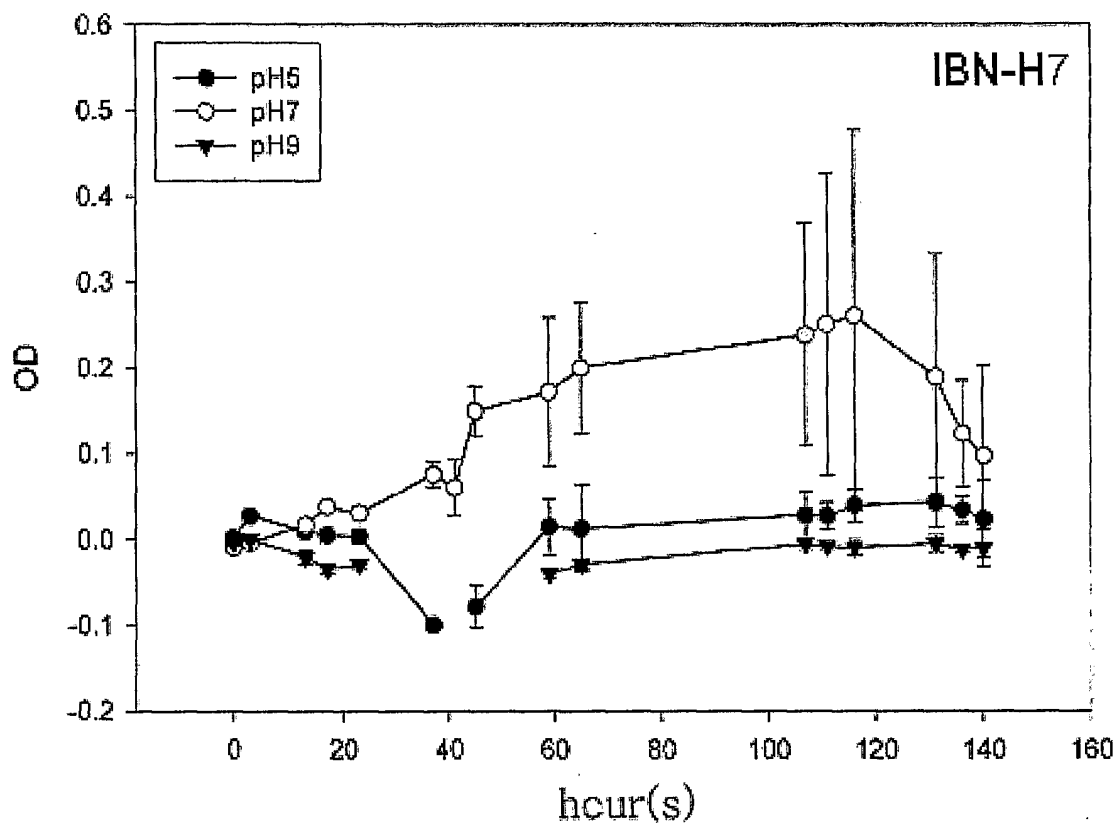

Fig. 3c

8/15

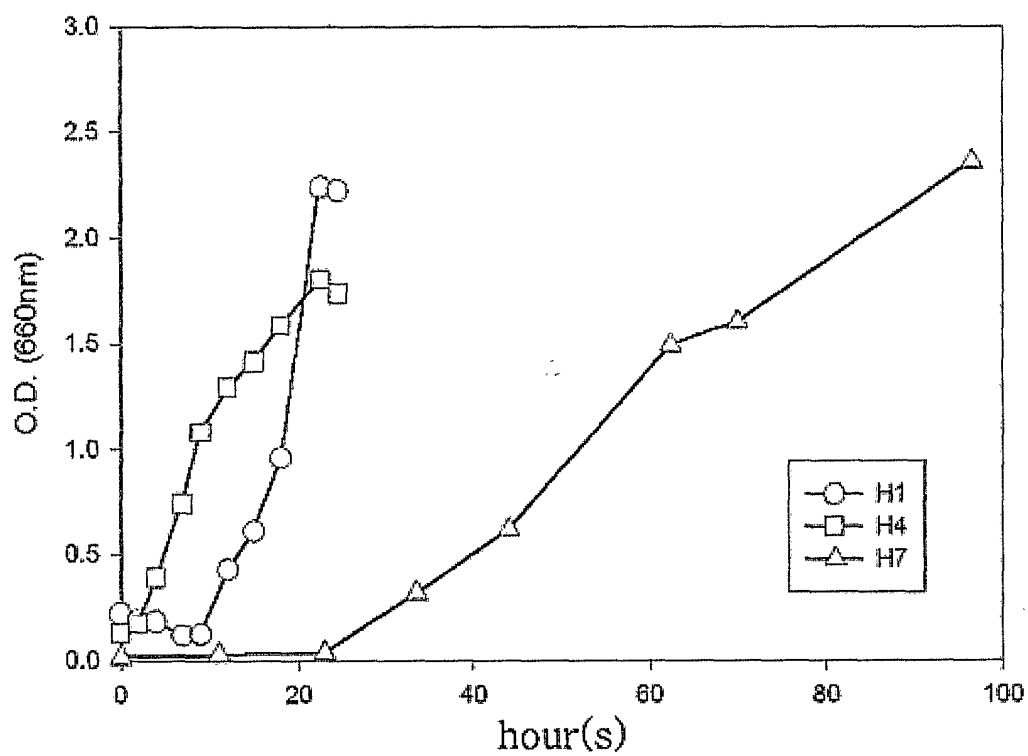

Fig. 4

9/15

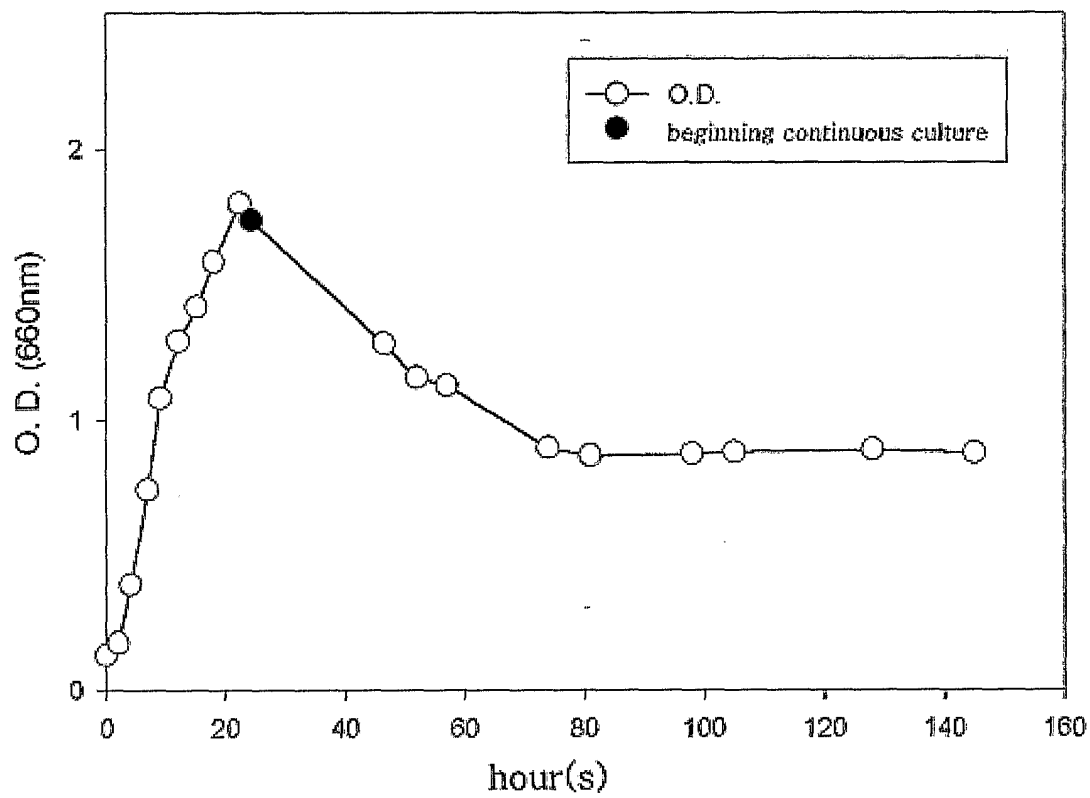

Fig. 5

10/15

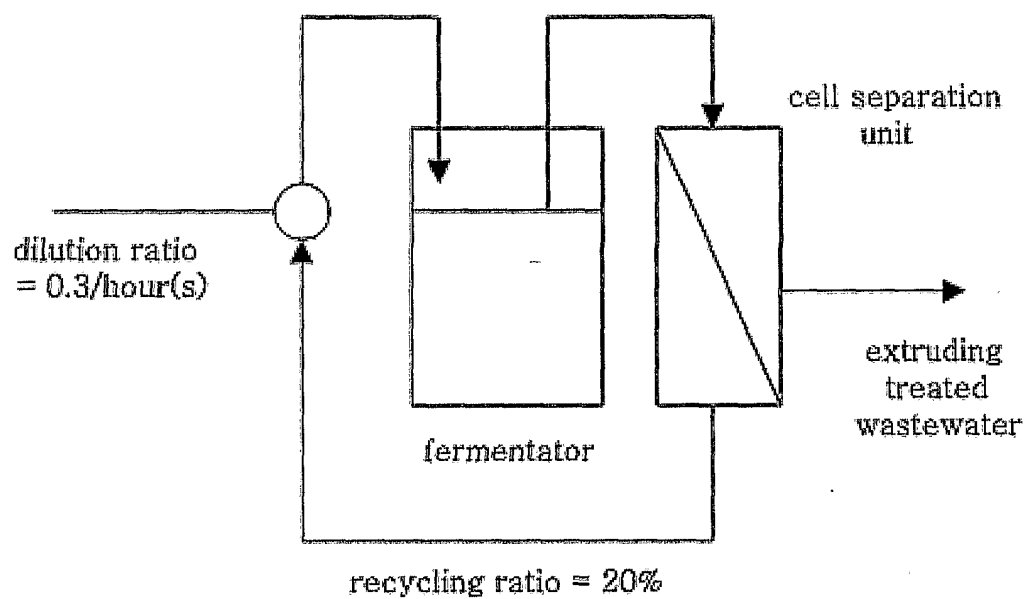

Fig. 6

11/15

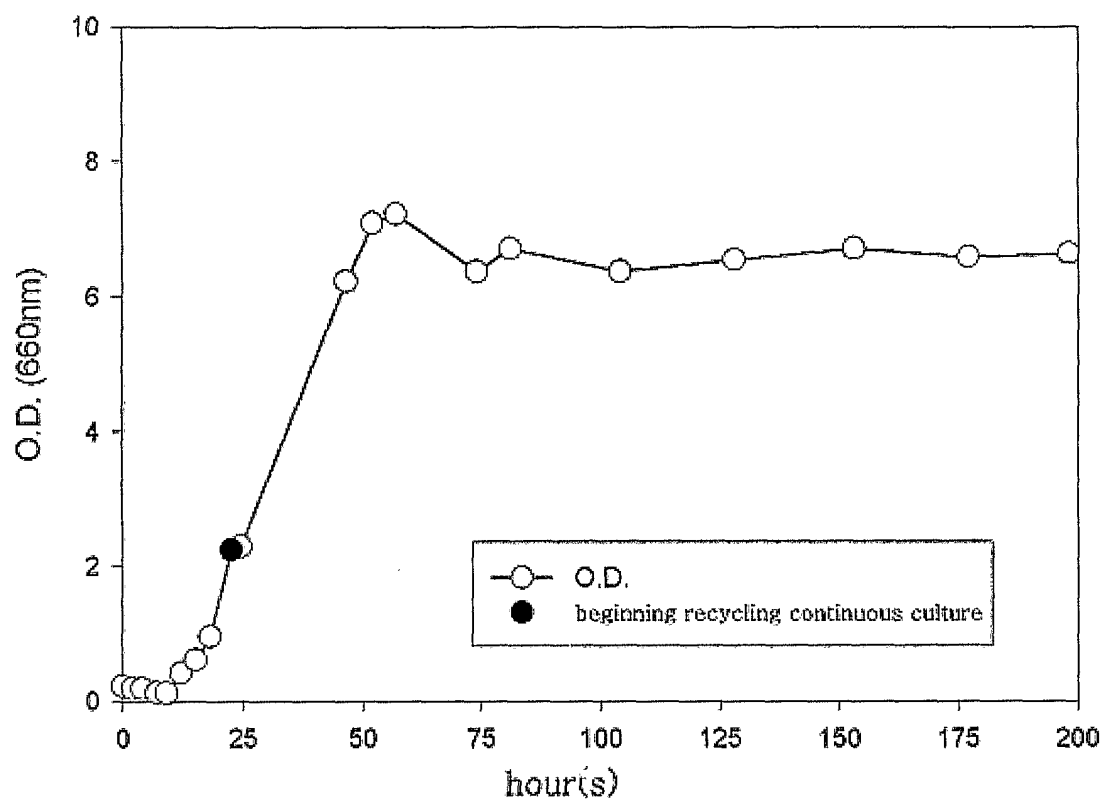

Fig. 7

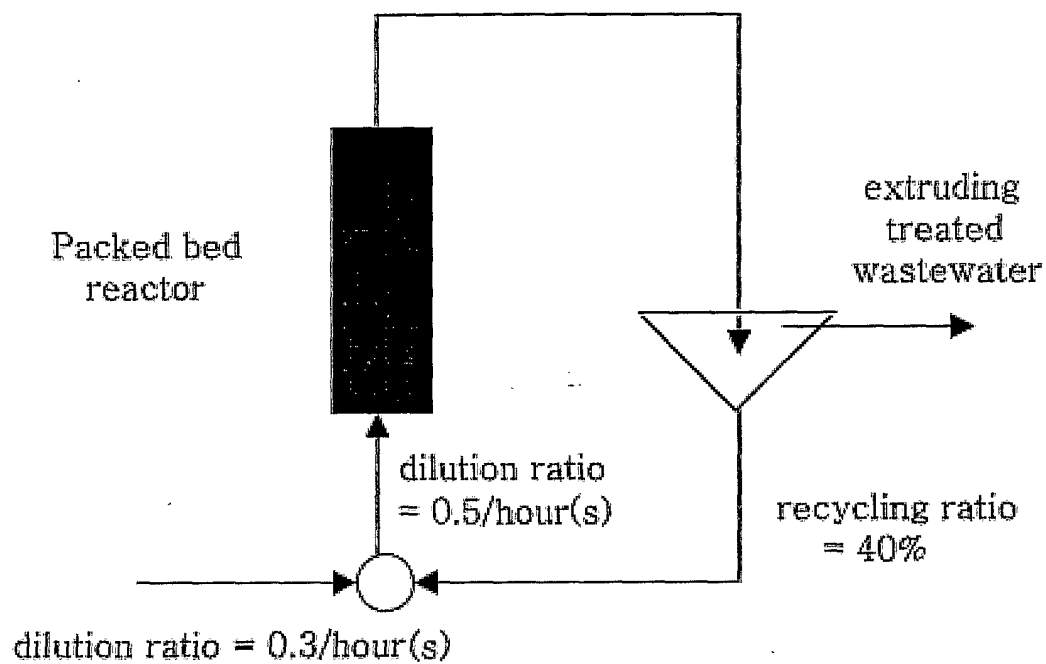

Fig. 8

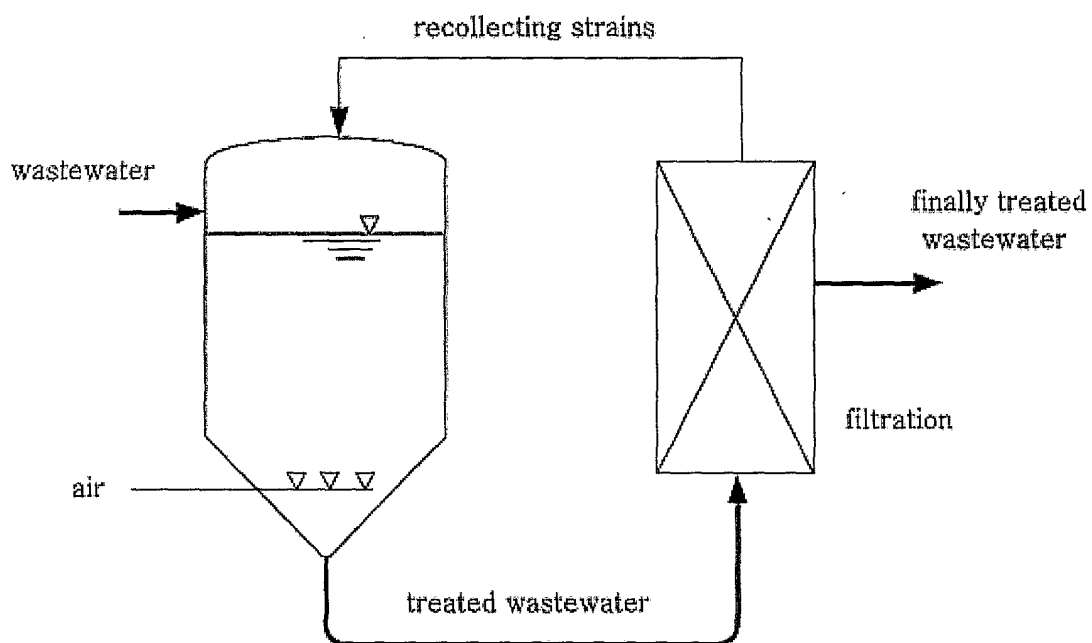

Fig. 9a

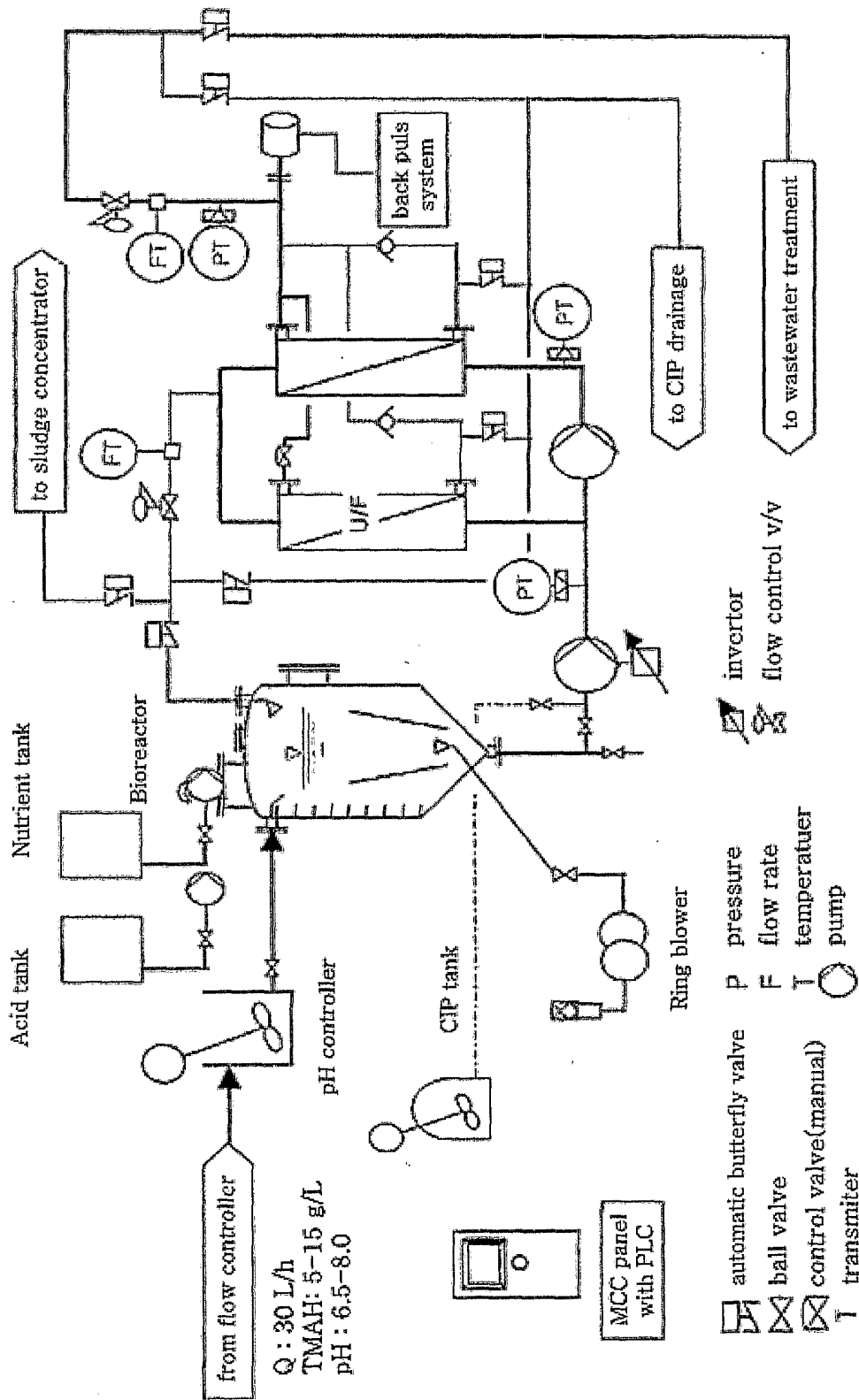

Fig. 9b

15/15

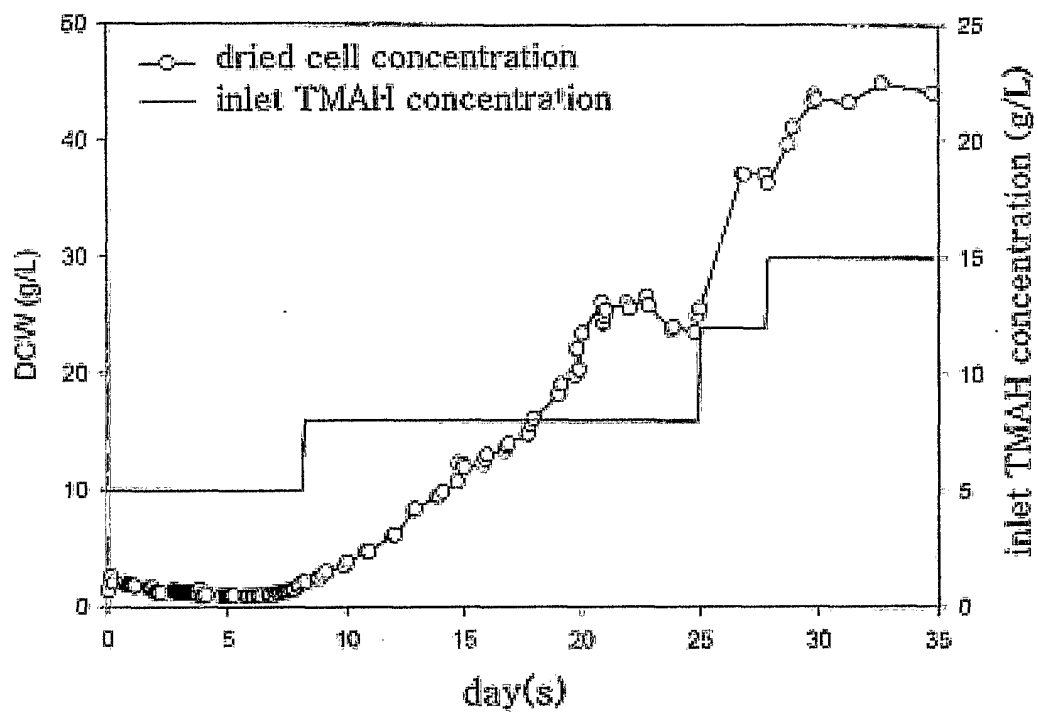

Fig. 10

<110> INBIONET CORPORATION
 <120> NOVEL STRAIN FOR DECOMPOSING TMAH, AND METHOD OF
 WASTEWATER TREATMENT USING THE SAME
 <130> PCT01-013
 <160> 2
 <170> KOPATIN 1.5
 <210> 1
 <211> 585
 <212> DNA
 <213> Bacillus cereus IBN-H4
 <400> 1
 ggcgcgctgc ctaatacatg caagtcgagc gaatggatta agagcttgct cttatgaagt 60
 tagcggcgga cgggtgagta acacgtgggt aacctgccca taagactggg ataactccgg 120
 gaaaccgggg ctaataccgg ataacattt gaacygcatg gttcgaaatt gaaaggcggc 180
 ttggctgtc acttatggat ggaccgcgt cgcattagct agttggtgag gtaacggctc 240
 accaaggcaa cgatgcgtag ccgacctgag aggtgatcg gccacactgg gactgagaca 300
 cggcccagac tcctacggga ggcagcagta gggaatctt cgcaatggac gaaagtctga 360
 cggagcaacg ccgctgagt gatgaaggct ttgggtcgt aaaactctgt ttttagggaa 420
 gaacaagtgc tagttgaata agctggcacc ttgacggtag ctaaccagaa agccacggct 480
 aactacgtgc cagcagccgc ggtaatacgt aggtggcaag cgttatccgg aattattggg 540
 cgtaaagcgc ggcgaggtgg tttcttaagt ctgatgtgaa agccc 585
 <210> 2
 <211> 517
 <212> DNA
 <213> Acinetobacter sp. IBN-H7
 <400> 2
 gcggcaggct taacacatgc aagccgagcg ggcgaggtt cttcggtaac tgagctagcg 60
 gcggacgggt gagtaatgct taggaatctg cctattagt ggggacaaca ttccgaaagg 120
 gatgctaata ccgcatacgt cctacgggag aaagcagggg ctctttatga cttgctgcta 180
 atagatgagc ctaagtcgga ttagctagtt ggtggggtaa aggcctacca aggcgacgat 240
 ctgtagcggg tctgagagga tgatccgcca cactgggact gagacacggc ccagactcct 300

acgggaggca gcagtgggga atattggaca atggggggaa ccctgatcca gccatgccgc 360
gtgtgtgaag aaggcctttt ggttgtaaag cactttaagt ggggaggagg cttacctggt 420
taataacctgg gctaagtgga cgttaccac agaataagca ccggctaact ctgtgccagc 480
agccgcggta atacagaggg tgcgagcgtt aatcgga 517

INTERNATIONAL SEARCH REPORT

ational application No.
PCT/KR01/00583

A. CLASSIFICATION OF SUBJECT MATTER
IPC7 C12N 1/20
According to International Patent Classification (IPC) or to both national classification and IPC

B. FIELDS SEARCHED
Minimum documentation searched (classification system followed by classification symbols)
C02F 3/34 ; C12N 1/20

Documentation searched other than minimum documentation to the extent that such documents are included in the fields searched
Korean Patent and Application for Inventions since 1975

Electronic data base consulted during the international search (name of data base and, where practicable, search terms used)
IPN, NPS, PAJ, Medline

C. DOCUMENTS CONSIDERED TO BE RELEVANT

Category*	Citation of document, with indication, where appropriate, of the relevant passages	Relevant to claim No.
A	JP 2-49576 (NEC CORP) 19 FEB 1990 see the whole document	1-7
A	US 5,532,162 (HALDOR AAMOT) 02 JUL 1996 see the whole document	1-7

Further documents are listed in the continuation of Box C. See patent family annex.

* Special categories of cited documents:
 "A" document defining the general state of the art which is not considered to be of particular relevance
 "E" earlier application or patent but published on or after the international filing date
 "L" document which may throw doubts on priority claim(s) or which is cited to establish the publication date of citation or other special reason (as specified)
 "O" document referring to an oral disclosure, use, exhibition or other means
 "P" document published prior to the international filing date but later than the priority date claimed
 "T" later document published after the international filing date or priority date and not in conflict with the application but cited to understand the principle or theory underlying the invention
 "X" document of particular relevance; the claimed invention cannot be considered novel or cannot be considered to involve an inventive step when the document is taken alone
 "Y" document of particular relevance; the claimed invention cannot be considered to involve an inventive step when the document is combined with one or more other such documents, such combination being obvious to a person skilled in the art
 "&" document member of the same patent family

Date of the actual completion of the international search 29 JUNE 2001 (29.06.2001)	Date of mailing of the international search report 29 JUNE 2001 (29.06.2001)
--	---

Name and mailing address of the ISA/KR Korean Intellectual Property Office	Authorized officer AHN, Mi-Chung
Facsimile No.	Telephone No.

