

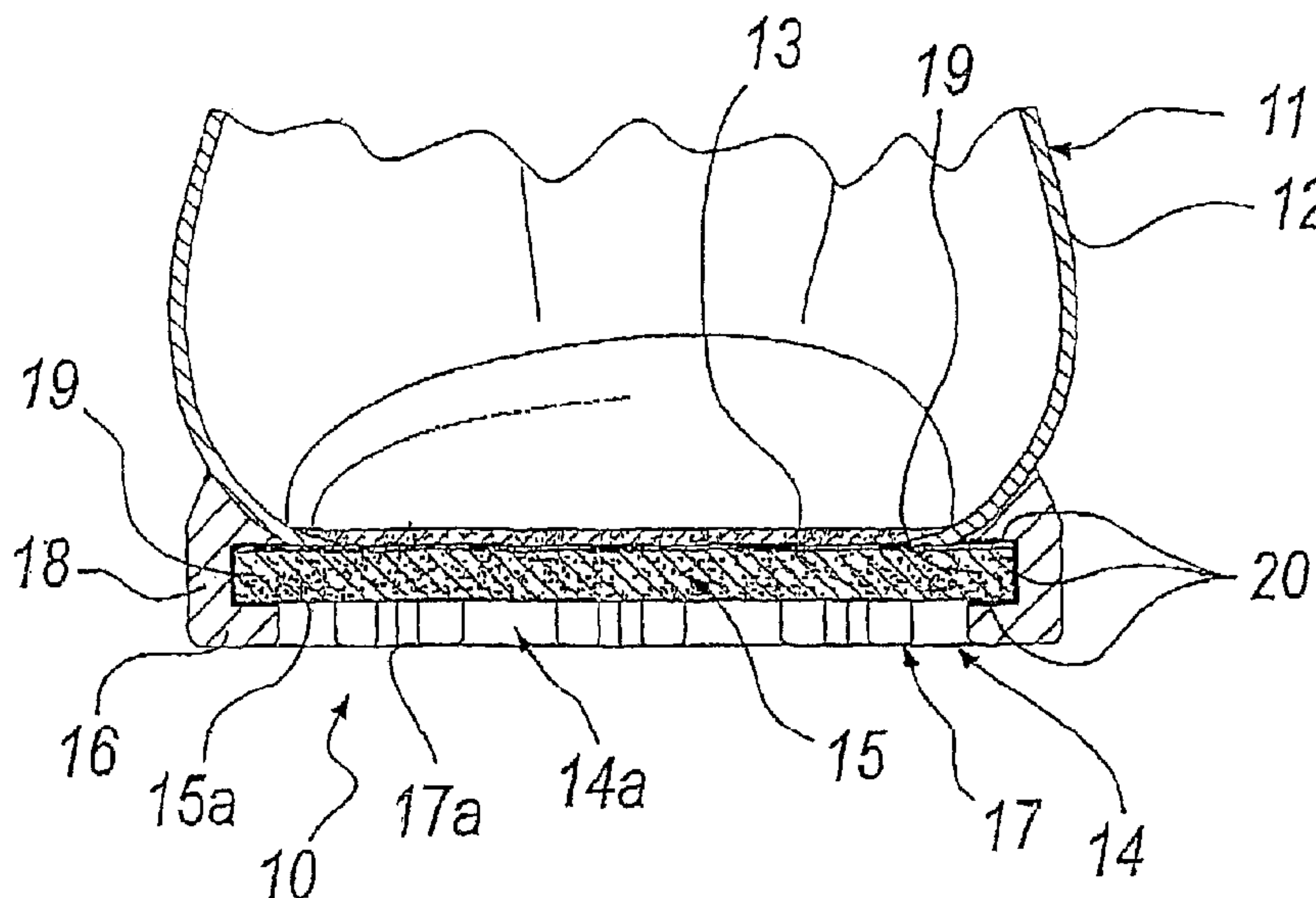

(22) **Date de dépôt/Filing Date:** 2004/12/27
 (41) **Mise à la disp. pub./Open to Public Insp.:** 2005/07/14
 (45) **Date de délivrance/Issue Date:** 2016/03/15
 (62) **Demande originale/Original Application:** 2 550 926
 (30) **Priorité/Priority:** 2003/12/30 (IT PD2003A000312)

(51) **Cl.Int./Int.Cl. A43B 7/06** (2006.01),
A43B 13/12 (2006.01), **A43B 7/12** (2006.01)
 (72) **Inventeurs/Inventors:**
 POLEGATO MORETTI, MARIO, IT;
 FERRARESE, ANTONIO, IT;
 MATTIONI, BRUNO, IT
 (73) **Propriétaire/Owner:**
 GEOX S.P.A., IT
 (74) **Agent:** MARKS & CLERK

(54) **Titre : SEMELLE ETANCHE RESPIRANTE POUR CHAUSSURES**
 (54) **Title: BREATHABLE WATERPROOF SOLE FOR SHOES**



(57) **Abrégé/Abstract:**

A waterproof breathable sole for shoes, which comprises, for at least part of its extension, at least two structural layers, a lower one provided with a supporting structure so as to form the tread, and an upper one that is permeable to water vapor. The lower layer has portions that are open onto the upper layer. A coating obtained by means of a plasma deposition treatment for waterproofing is provided on the upper layer. In this manner, a layer is obtained that has structural functions and characteristics of resistance to damage and is at the same time waterproof and breathable.

ABSTRACT

A waterproof breathable sole for shoes, which comprises, for at least part of its extension, at least two structural layers, a lower one provided with a supporting structure so as to form the tread, and an upper one that is permeable to water vapor. The lower layer has portions that are open onto the upper layer. A coating obtained by means of a plasma deposition treatment for waterproofing is provided on the upper layer. In this manner, a layer is obtained that has structural functions and characteristics of resistance to damage and is at the same time waterproof and breathable.

BREATHABLE WATERPROOF SOLE FOR SHOES

This is a divisional application of Canadian Patent Application Serial No. 2,550,926 filed on December 27, 2004.

Technical Field

5 The present invention relates to a breathable waterproof sole for shoes. It should be understood that the expression "the invention" and the like used herein may refer to subject matter claimed in either the parent or the divisional applications.

Background Art

10 The present invention also relates to a shoe manufactured with such sole. It is known that the footwear market is continuously evolving in order to seek and identify technical solutions that ensure optimum comfort for the end-user of the shoe.

As is well known, the comfort of a shoe depends not only on a correctly anatomical fit but also on correct outward permeation of the water vapor generated inside the shoe due to perspiration, in order to avoid the so-called "wet foot" phenomenon.

15 However, this water vapor permeation must not compromise the waterproofness of the shoe, and therefore solutions have been studied which entrust permeation to the upper or to the sole.

20 Most of the perspiration of the foot is produced at the interface between the sole of the foot and the sole of the shoe, and it is evident that the sweat that forms there is unable to evaporate and therefore condenses on the insole on which the foot rests. Only a minimal fraction of the sweat
25 evaporates through the upper.

This problem is particularly important in shoes that have a plastic sole; in these cases, permeation through the sole is completely prevented (in the case of leather soles there is instead a small amount of permeation).

30 Solutions to the problem are provided by breathable and waterproof soles, which accordingly allow permeation of the sweat generated at the sole of the foot.

One of these solutions is disclosed in US-5,044,096 and in EP-0382904 and consists in dividing the plastic sole into two layers with through holes and in interposing a waterproof breathable membrane (for example made of a material such as Gore-Tex® or the like), which is joined
5 perimetrically and hermetically to the two layers, so as to allow no infiltrations of water.

This solution ensures correct permeation as well as an effective
10 exchange of heat and water vapor between the environment inside the shoe and the outside environment, at the same time ensuring the necessary impermeability with respect to external moisture and water.

These perforated soles provided with waterproof and breathable membranes have certainly constituted a considerable innovation with
15 respect to what was previously available.

Nonetheless, there are still aspects that can be improved, particularly in relation to the area occupied by the holes.

As is evident, the larger the total hole area, the greater the breathability; however, on the other hand, the number of holes provided in
20 the tread and their diameter must be limited in order to prevent pointed foreign objects from entering through the holes and penetrating until they damage or pierce the membrane, which is delicate, since in practice it is a film and lacks adequate structural characteristics.

Such membrane is in fact continuously subjected to the compression
25 performed by the foot, and therefore even a body that is not particularly pointed that penetrates one of the holes may cause damage without excessive difficulty.

One solution that has been adopted is to use a breathable protective layer, such as a felt, between the tread and the membrane.

30 Moreover, dirt, dust and pebbles may wedge in the holes of the tread,

obstructing them and thus limiting breathability.

A different solution with respect to the use of a waterproof and breathable membrane lacking structural characteristics is disclosed in US 6,508,015.

5 This patent discloses a sole that is provided by a structure with two layers, respectively an elastic upper layer, which is permeable to water vapor, and a lower layer, which covers less than 70% of the upper layer, which also acts as a support and as a tread.

10 The permeation activity of the sole is ensured by the microporous structure of the upper layer and by the shape of the lower layer.

The microporous structure of the upper layer is provided for example by means of sintered plastic material or by means of woven or non-woven structures made of synthetic material.

15 However, this layer does not have strictly waterproof characteristics; for this purpose, the patent mentions the possibility of rendering this layer hydrophobic, for example by treating the sintered polyethylene in high or ultra-high molecular weight conditions.

20 Another possibility for the waterproofing disclosed in the patent is to add, above the upper layer, an additional layer formed by a waterproof membrane.

Although this described solution solves the problem of the breathable area of the sole, which is large, it does not adequately meet the requirement of waterproofing said sole.

25 It has in fact been found that the hydrophobic treatment of the sintered material does not make the upper layer sufficiently waterproof, especially in the case of large amounts of water.

30 Moreover, the idea of coupling an impermeable membrane to the inner layer is not in itself sufficient to ensure perfect insulation from water, since infiltrations of water along the perimeter of the upper layer are possible.

Another problem that is linked to this type of sole is that the upper layer tends in any case to absorb considerable amounts of water ("sponge effect"), which is released over time, leading to evident soiling of the surfaces on which one walks.

5 This problem becomes more evident as the size of the pores of the material increases.

Already for pore dimensions of more than 5 μm , there is penetration of unclean water (dirty or soapy water): in this case, the surface tension is lower than the typical value of water (73 mN/mm).

10 Disclosure of the Invention

The aim of the present invention is to provide a breathable waterproof sole for shoes that solves the problems noted in known soles.

15 Within this aim, an object of the present invention is to provide a breathable waterproof sole for shoes that uses a waterproof and breathable structural layer and at the same time ensures higher breathability than known shoes.

Another object of the present invention is to provide a breathable waterproof sole for shoes that is resistant to wear and damage.

20 Another object of the present invention is to provide a breathable and waterproof sole for shoes that is composed of a smaller number of components than known soles.

Another object of the present invention is to provide a breathable and waterproof sole for shoes that can be manufactured with known systems and technologies.

25 This aim and these and other objects that will become better apparent hereinafter are achieved by a waterproof breathable sole for shoes comprising, for at least part of its extension, at least two structural layers, a lower one provided with a supporting structure so as to form the tread, and an upper microporous one that is permeable to water vapor, said lower layer
30 having portions that are open onto said upper layer, said sole being

characterized in that at least one of the two surfaces of said upper layer has a coating obtained by means of a plasma deposition treatment for waterproofing.

In one aspect, the invention provides a waterproof breathable sole for shoes, comprising, for at least part of its extension, at least two structural layers, a lower one provided with a supporting structure so as to form the tread, and an upper microporous one that is permeable to water vapor, said lower layer having portions that are open onto said upper layer, wherein at least one of the two surfaces of said upper layer has a coating obtained by means of a plasma deposition treatment for waterproofing.

In one aspect, the invention provides a waterproof and breathable shoe, comprising:

an assembly, which surrounds in a pouch-like manner the foot insertion region and comprises a breathable upper with which a waterproof membrane is associated at least in a downward region; and

a sole, which is associated below the assembly and comprises, along at least part of its extension, at least two structural layers, a lower one having a supporting structure so as to form the tread, the upper one being microporous and permeable to water vapor, the lower layer having portions that are open onto the upper layer;

wherein the lower layer of the sole covers a percentage of the upper layer of the sole that is comprised of between 30% and 70%; and

wherein the assembly is composed of an upper that is coupled externally to the sole by means of its lower edges and internally to a waterproof membrane that forms a pouch for containing foot.

In one aspect, the invention provides a waterproof and breathable shoe, comprising:

5a

an assembly, which surrounds in a pouch-like manner the foot insertion region and comprises a breathable upper with which a waterproof membrane is associated at least in a downward region; and

5 a sole, which is associated below the assembly and comprises, along at least part of its extension, at least two structural layers, a lower one having a supporting structure so as to form the tread, the upper one being microporous and permeable to water vapor, the lower layer having portions that are open onto the upper layer;

10 wherein the assembly is composed of the upper and of a breathable or perforated insole, which is joined to the edges of the upper by means of stitches according to the structure known as strobil or ideal welt, so as to form a pouch, the waterproof membrane adhering to the breathable or perforated insole, the assembly comprising, along the perimeter of the waterproof membrane, a sealing area that straddles the stitched seams
15 and said waterproof membrane.

Brief Description of the Drawings

Further characteristics and advantages of the invention will become better apparent from the description of some preferred but not exclusive embodiments thereof, illustrated by way of non-limiting example in the
20 accompanying drawings, wherein:

Figure 1 is a transverse sectional view of a portion of a shoe with a sole according to the invention;

Figure 2 is a transverse sectional view of a detail of a sole according to Figure 1;

25 Figure 3 is a view of a detail of a variation of the sole shown in Figure 1;

Figure 4 is a plan view of the sole of Figure 1;

Figure 5 is a plan view of another variation of the sole of Figure 1;

5b

Figure 6 is a transverse sectional view of a portion of a shoe with an embodiment of the sole according to the invention that is alternative with respect to the embodiments of the previous figures;

5 Figure 7 is a perspective view of a shoe with a sole according to the invention;

Figure 8 is a transverse sectional view of a portion of another shoe according to the invention, which is alternative with respect to the shoes of the preceding figures;

10 Figure 9 is a transverse sectional view of a portion of another shoe according to the invention, which is alternative with respect to the shoes of the preceding figures.

Ways to carrying out the Invention

With reference to the figures, a first embodiment of the sole according to the invention is generally designated by the reference numeral

10.

Figure 1 is a transverse sectional view of a shoe related to the region of the sole 10; this figure clearly shows that the sole 10 comprises, in this embodiment, two layers, which compose respectively a lower layer 14 and an upper layer 15 that is permeable to water vapor.

Both of the layers 14 and 15 are structural and therefore have a supporting function; in particular, the lower layer 14 has a supporting structure so as to form the tread of the sole 10, while the upper layer 15 forms the foot supporting base and has elasticity and flexibility characteristics.

In order to allow breathability of the upper layer 15, the lower layer 14 has portions 14a that are open onto the upper layer 15, so that it is exposed directly to the external environment; such open portions 14a are described in greater detail hereinafter.

The upper layer is microporous and is for example made of sintered plastics material.

Conveniently, the plastics material that is used can be any of polyethylene, polypropylene, polystyrene or polyester.

Optionally, the upper layer 15 can be constituted by any of a felt, a fleece, a fabric or mesh, made of synthetic material.

In order to ensure adequate permeability to water vapor and allow subsequent surface treatments of the upper layer 15 (as described hereinafter), the average width of the pores is comprised between 3 and 250 μm .

Preferably, the average width can be comprised between 3 and 5 μm .

The lower layer 14 is made of plastics, such as for example polyurethane.

The lower layer 14 is constituted by a perimetric skirt 16 that constitutes the outer edge of the sole, and by ground contact elements 17, which act as a support for the upper layer 15 (which otherwise would

collapse within the perimeter of the skirt).

The spaces of the lower layer 14 that are comprised between the various ground contact elements 17 and between the ground contact elements and the skirt 16 form the portions 14a.

5 In this embodiment, the perimetric skirt 16 has a lateral portion 18 that includes a perimetric contour 19 of the upper layer 15 so as to form perimetric regions of mutual contact 20 between layers 14 and 15.

In this lateral portion 18, the upper layer 15 and the lower layer 14 are hermetically joined along their perimeter in order to avoid infiltrations of
10 water.

Preferably, the coupling between the layers 14 and 15 occurs by overmolding the lower layer 14 onto the upper layer 15; in this case, hermetic complete coupling is ensured by the perfect adhesion provided by overmolding.

15 As an alternative, it is possible to use other production methods, such as for example adhesive bonding methods; in this case, however, the coupling of the upper layer 15 to the lower layer 14 provides for sealant in the perimetric regions of mutual contact 20.

The ground contact elements 17, in this described embodiment, are
20 separated from the skirt 16 and are provided for example by overmolding directly on the lower surface 15a of the upper layer 15, so as to form in practice studs 17a that supports the upper layer 15 and ensure the grip of the sole 10.

Variations of these ground contact elements, now designated by the
25 reference numeral 117 in Figure 5, provide for example continuous transverse elements 117a, which are provided monolithically with the skirt 116.

The portions 114a are formed between the transverse continuous elements 117a and the skirt 116.

30 For correct permeation, it is important that the lower layer cover the

smallest possible extent of the upper layer.

For example, conveniently, the lower layer can cover a percentage of the upper layer that is comprised between 30% and 70%.

The upper layer 15 has, on its upper surface 15b, a coating 21
5 obtained by means of a plasma deposition treatment, which allows waterproofing (and also maintains breathability).

As an alternative, as shown in Figure 3, it is possible to provide a coating, designated by the reference numeral 221, which is obtained by means of a plasma deposition treatment on a lower surface 215a of a lower
10 layer 215.

It is optionally possible to provide such coating on both of the surfaces of the lower layer 15,215.

The idea of coating by plasma deposition arises from the surprising experimental discovery that a vapor of a siloxane organic compound can be
15 used to produce an ultrathin layer on a microporous supporting material by "cold plasma" polymerization in high vacuum at ambient temperature, providing waterproofing characteristics without altering the general characteristics and in particular the breathability characteristics of the supporting material.

20 A waterproof and breathable membrane can in fact be created by plasma polymerization for example of a monomer based on siloxane by depositing a layer of polymer (polysiloxane) on a microporous supporting material (made for example of polyethylene or polystyrene).

This deposition can also be performed for example by using oil-
25 repellent and water-repellent fluoropolymers, such as those manufactured by DuPont and registered with the trade name Zonyl®.

Plasma is divided into hot and cold depending on the temperatures that it reaches; it is also divided into ambient-pressure plasma and vacuum plasma.

30 In a plasma process for obtaining a coating according to the present

invention, a gaseous or vaporized precursor compound is introduced in a reaction chamber at a very low pressure (in vacuum conditions).

A plasma condition is generated by energizing the precursor within the reaction chamber by generating an electrical field.

5 The result is an ultrathin bonded layer of the polymer deposited on the entire surface of any substrate material introduced in the reaction chamber.

The plasma polymerization process is started and performed by means of an electrical field so as to achieve breakdown of the precursor of the
10 deposition layer inside the reaction chamber.

Once breakdown has occurred, ions and reactive species are formed which begin and assist the atomic and molecular reactions that lead to the formation of thin films.

Layers created by plasma polymerization may use various
15 configurations of electrical fields and different reaction parameters.

The thickness of the layer is controlled by selecting the polymerizable initial material and the reaction conditions, such as the monomer deposition time, the treatment time, the electrical frequency at which the reaction is performed, and the power that is used.

20 In the present invention, plasma polymerization is performed in vacuum.

The typical range of pressures is between 10^{-1} and 10^{-5} mbar.

The precursor is typically reacted in its pure state, by using a non-polymerizable inert gas, such as for example argon; such inert gas is used
25 both as an inert diluent and as a carrier gas that assists polymerization of the precursor.

Other gases that can be used are oxygen, helium, nitrogen, neon, xenon and ammonia.

The precursor must have a vapor pressure that is sufficient to allow
30 vaporization in a moderate vacuum.

A reaction sequence generally begins by loading the support material to be coated into the reaction chamber and subsequently bringing the chamber to the intended vacuum pressure.

The plasma generating discharge is produced and the vaporized precursor monomer is injected into the reaction chamber.

Collision of the monomer with the ions and electrons of the plasma allows polymerization of the monomer.

The resulting polymer is deposited on the exposed surfaces inside the chamber.

The properties of the film are not only a function of the structure of the monomer but are also a function of the discharge frequency, of the power used, of the flow-rate of the monomer and of the pressure.

Porosity, surface morphology and permeability may vary according to the reaction conditions.

An important variable in the plasma polymerization reaction is the rate of deposition of the polymer, which can be changed by means of the flow-rate of the monomer.

The deposition process ends when the intended thickness of deposited material is reached.

Thanks to the fact that the upper layer 15 is made of insulating material (for example, polyethylene is one of the most highly insulating materials known), in order to maintain the plasma conditions it is necessary to apply to the process a radiofrequency generator, so that the electrical field in the treatment oscillates with a frequency on the order of 13.56 MHz, with an applied electrical field power of 50-700 W and a vacuum level comprised between 10^{-1} and 10^{-5} mbar.

The microporous upper layer 15 must have an average pore width comprised between 3 and 250 μm .

As regards the duration of the treatment, it has been studied that for a precursor such as a siloxane monomer the optimum time is comprised

substantially between 160 and 600 seconds; in particular, an optimum duration of substantially 420 seconds has been found.

Regardless of the plasma deposition treatment, it is further possible to render the upper layer 15 hydrophobic by treating for example the sintered polyethylene in high- or ultra-high molecular weight conditions.

Figure 6 is a view of a portion of a shoe with an alternative embodiment of a sole, generally designated here by the reference numeral 300, which uses a waterproof membrane 321.

In practice, as in the preceding case, the sole 300 comprises a lower structural layer 314 with a supporting structure so as to form the tread and an upper microporous structural layer 315 that is permeable to water vapor: the lower layer 14 is provided with portions 314a that are open onto the upper layer 315 in order to allow breathability.

The waterproof membrane 321 is coupled in an upward region to the upper structural layer 315.

The upper layer 315 has structural functions for supporting the foot and functions for protecting the waterproof membrane 321.

In this case, however, the upper layer 315 and the waterproof membrane 321 must be hermetically joined along their perimeter in order to prevent water infiltrations.

As already known, the waterproof membrane 321 can optionally be coupled (so as to withstand hydrolysis without compromising breathability), with a supporting mesh (not shown in the figures, since it is a known element) made of synthetic material.

The membrane 321 can be fixed to the upper layer 315, for example, by lamination directly onto the upper layer 315 or can be fixed subsequently by adhesive spots according to methods that are per se known.

As previously, the coupling between the lower layer 314 and the upper layer 315 with the membrane 321 coupled thereto preferably occurs by overmolding the lower layer 314 onto the assembly constituted by the

upper layer 315 and the membrane 321; in this case, the hermetic coupling is ensured by the perfect adhesion provided by overmolding.

As an alternative, it is possible to use other production methods, such as for example adhesive bonding techniques; in this case, however, sealant is provided along the perimeter where the membrane makes contact with the directly overlying layer.

Figure 7 illustrates a shoe 11 that is constituted by a sole 10,300, as described in one of the previous examples, by an upper 12, and by an insole 13.

Figure 8 illustrates a breathable and waterproof shoe 411, which comprises an assembly 401 that wraps around the foot insertion region like a pouch and is constituted by a breathable upper 412 with which a waterproof membrane 421 is associated in a downward region.

A sole 400 is associated below the assembly 401 and comprises, like the sole examples described earlier, two component layers, respectively a lower layer 414 and an upper layer 415, which is microporous and permeable to water vapor.

Both of said layers 414 and 415 are structural and therefore have a supporting function; in particular, the lower layer 414 has a supporting structure so as to form the tread of the sole 400, while the lower layer 415 forms the foot supporting base and has elasticity and flexibility characteristics.

In order to allow breathability of the upper layer 415, the lower layer 414 has portions 414a that are open onto said upper layer 415, so that it is directly exposed to the outside environment.

In this embodiment, the assembly 401 is composed of the upper 412 and of a breathable or perforated insole 413, which is joined by means of stitches 402 to the edges of said upper 412 according to the per se known "strobels" or "ideal welt" structure so as to form a pouch.

In this embodiment, the waterproof membrane 421 adheres only to the

insole 413 and can be applied for example by direct lamination onto the insole before sewing to the upper 412 or can be applied subsequently for example by spot gluing.

In order to avoid water infiltration problems, the assembly 401
5 comprises, along the perimeter of the waterproof membrane 421, a sealing area 421a that straddles the stitched seams 402 and said membrane 421, reaching the upper layer 415.

An alternative embodiment with respect to the shoe 411 is described in Figure 9 and is generally designated by the reference numeral 511.

10 The differences with respect to the embodiment of the shoe 411 substantially relate only to the part related to the assembly, here designated by the reference numeral 501, that surrounds in a pouch-like manner the foot insertion region and with which a sole 500 is associated in a downward region which is composed of a lower layer 514 and an upper layer 515 such
15 as the ones described previously.

Such pouch is sealed and rendered waterproof according to known techniques.

The assembly 501 is composed of an upper 512, which is externally coupled to the sole 500 by means of its lower edges 512a and is internally
20 coupled to a waterproof membrane 521, which forms a pouch for containing foot insertion.

The waterproof membrane 521 is fixed for example to the upper 512 by spot gluing, so as to avoid compromising breathability through said upper.

25 An inner sheet of fabric 521a is coupled to the waterproof membrane 521 toward the inside of the shoe and together with said membrane forms the inner lining of the shoe.

In this case also, the coupling of the assembly 501 to the sole 500 occurs by means of per se known techniques, such as for example direct
30 overmolding of the sole, adhesive bonding, et cetera.

Advantageously, in all of the described embodiments (except for those in which another material is explicitly required for construction reasons), the upper microporous layer that is permeable to water vapor (15, 215, 315, 415, 515) can be made of leather.

5 In practice it has been observed that the invention thus described solves the problems noted in known types of sole for shoes; in particular, the present invention provides a breathable and waterproof sole that has a structural element, the upper layer, which in addition to performing foot supporting functions is also designed to ensure breathability and
10 waterproofing, since it is directly exposed to the outside environment.

Waterproofing has been ensured by the coating of the upper layer obtained by means of the plasma treatment.

In this manner, the characteristic of waterproofing has been associated with a structural component of the sole (the upper layer) that has
15 breathability characteristics.

The structural characteristic and the strength of the upper layer allows to prevent foreign pointed objects from penetrating to the point of damaging or piercing it and therefore from rendering the waterproofing substantially
useless.

20 In this manner, it is possible to ensure a large surface (the part of the upper layer that is not covered by the lower layer) for breathability of the sole, considerably reducing the possibility of condensation of water vapor inside a shoe.

By using plasma deposition, the problems of conformity and adhesion
25 of a thin film to a support are solved, since the polymer adheres to the support for a longer time than conventional spreading (typically, the waterproof membranes that are currently used are produced separately and then bonded by spot gluing or laminated or spread directly onto the support).

30 With this plasma deposition, it is possible to create an extremely thin

deposition layer on the supporting material, even on the order of 100 Angstrom.

The selection of the sintered plastic material for providing said upper layer, moreover, allows the necessary flexibility of the sole and allows to
5 overmold the tread in an optimum manner.

In one described embodiment, preference has been given to using, instead of coating by plasma deposition, a waterproof membrane coupled to the upper breathable layer.

In this case, the invention solves the problems of known shoes that
10 use such sole structures, by joining perimetrically and hermetically the waterproof membrane and the upper breathable layer.

In the last three embodiments described, the invention has advantageously combined a supporting sole structure, which has large areas for vapor permeation toward the ground, with an assembly that forms a
15 pouch for foot insertion that is completely breathable (both laterally and in a downward region) and is impermeable at least in the direction of the sole; in particular, in the shoes designated by the reference numerals 500 and 600, a pouch for foot insertion that is completely breathable and impermeable has been obtained.

20 In all of the embodiments provided with a membrane described above, the upper layer continues to have structural supporting functions as well as a membrane protection functions.

The embodiments of the invention in which an exclusive property or privilege is claimed are defined as follows:

1. A waterproof and breathable shoe, comprising:
an assembly, which surrounds in a pouch-like manner the foot insertion region and comprises a breathable upper with which a waterproof membrane is associated at least in a downward region; and
a sole, which is associated below the assembly and comprises, along at least part of its extension, at least two structural layers, a lower one having a supporting structure so as to form the tread, the upper one being microporous and permeable to water vapor, the lower layer having portions that are open onto the upper layer;
wherein the lower layer of the sole covers a percentage of the upper layer of the sole that is comprised of between 30% and 70%; and
wherein the assembly is composed of an upper that is coupled externally to the sole by means of its lower edges and internally to a waterproof membrane that forms a pouch for containing foot.
2. The shoe according to claim 1, wherein the microporous upper layer that is permeable to water vapor is made of leather.
3. The shoe according to claim 1 or 2, wherein the waterproof membrane is fixed to the upper by spot gluing, so as to avoid compromising breathability through the upper.
4. The shoe according to any one of claims 1 to 3, wherein the lower layer has a perimetric skirt, the perimetric skirt having a lateral portion which includes a perimetric contour of the upper layer to form perimetric regions of mutual contact between the lower and upper layers, the perimetric regions being L-shaped in the transverse cross section.

1/4

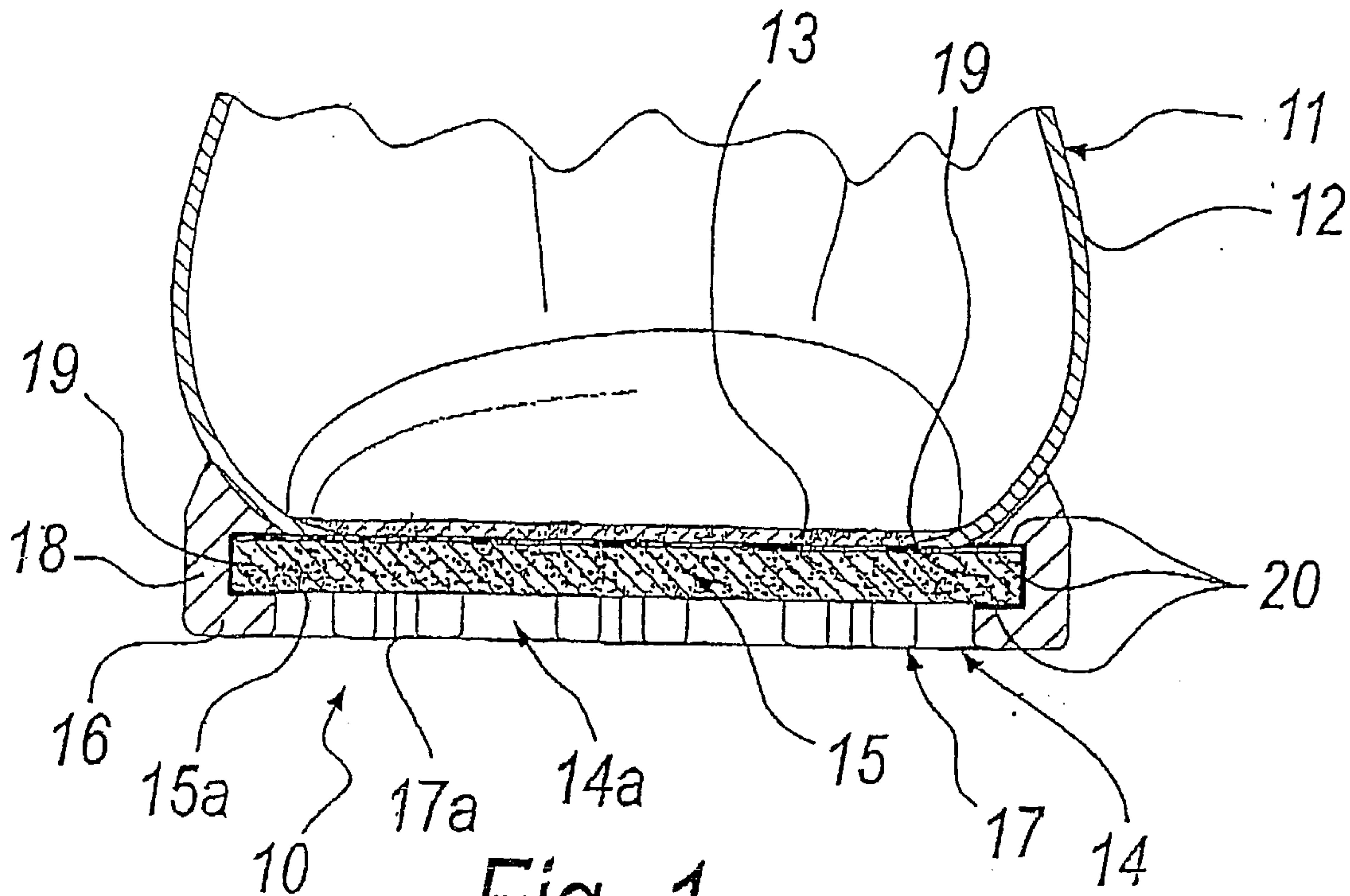

Fig. 1

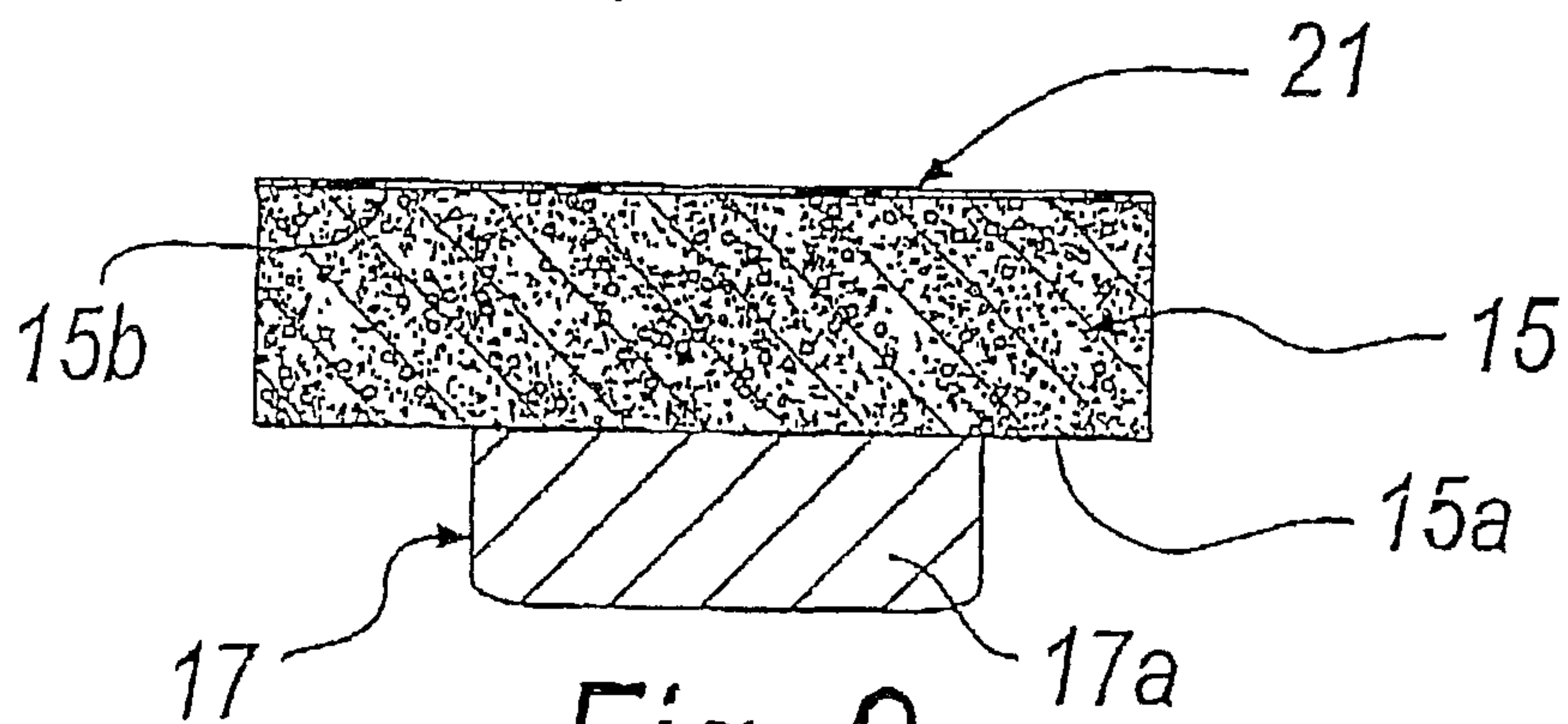

Fig. 2

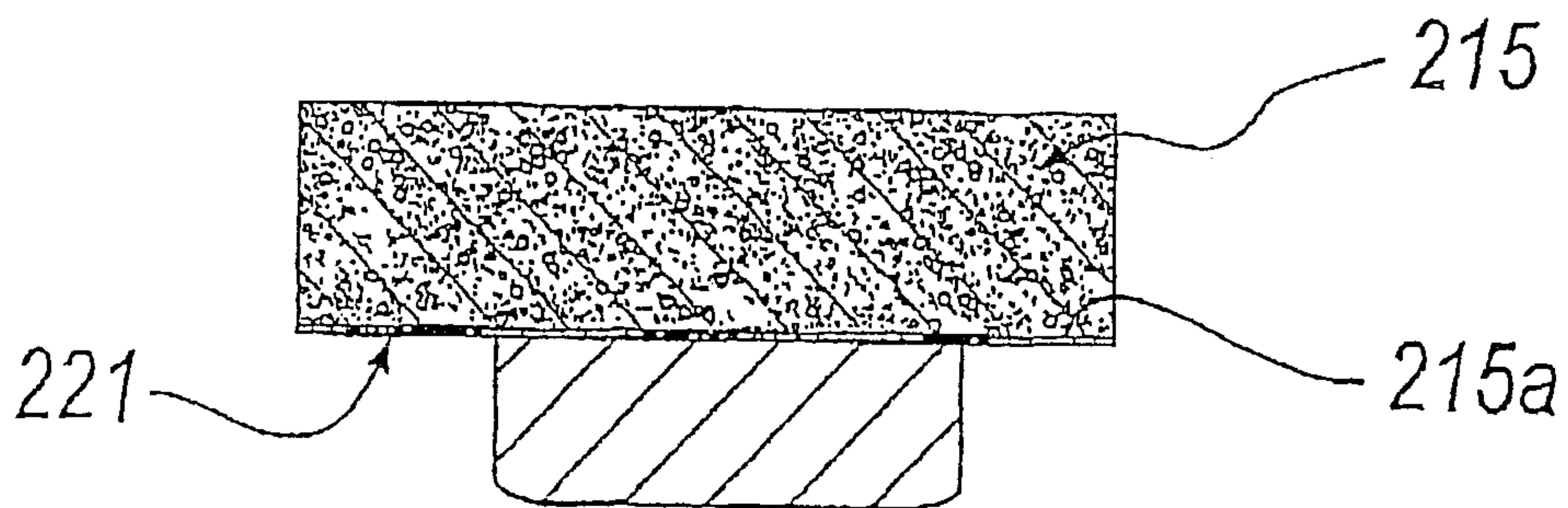

Fig. 3

2/4

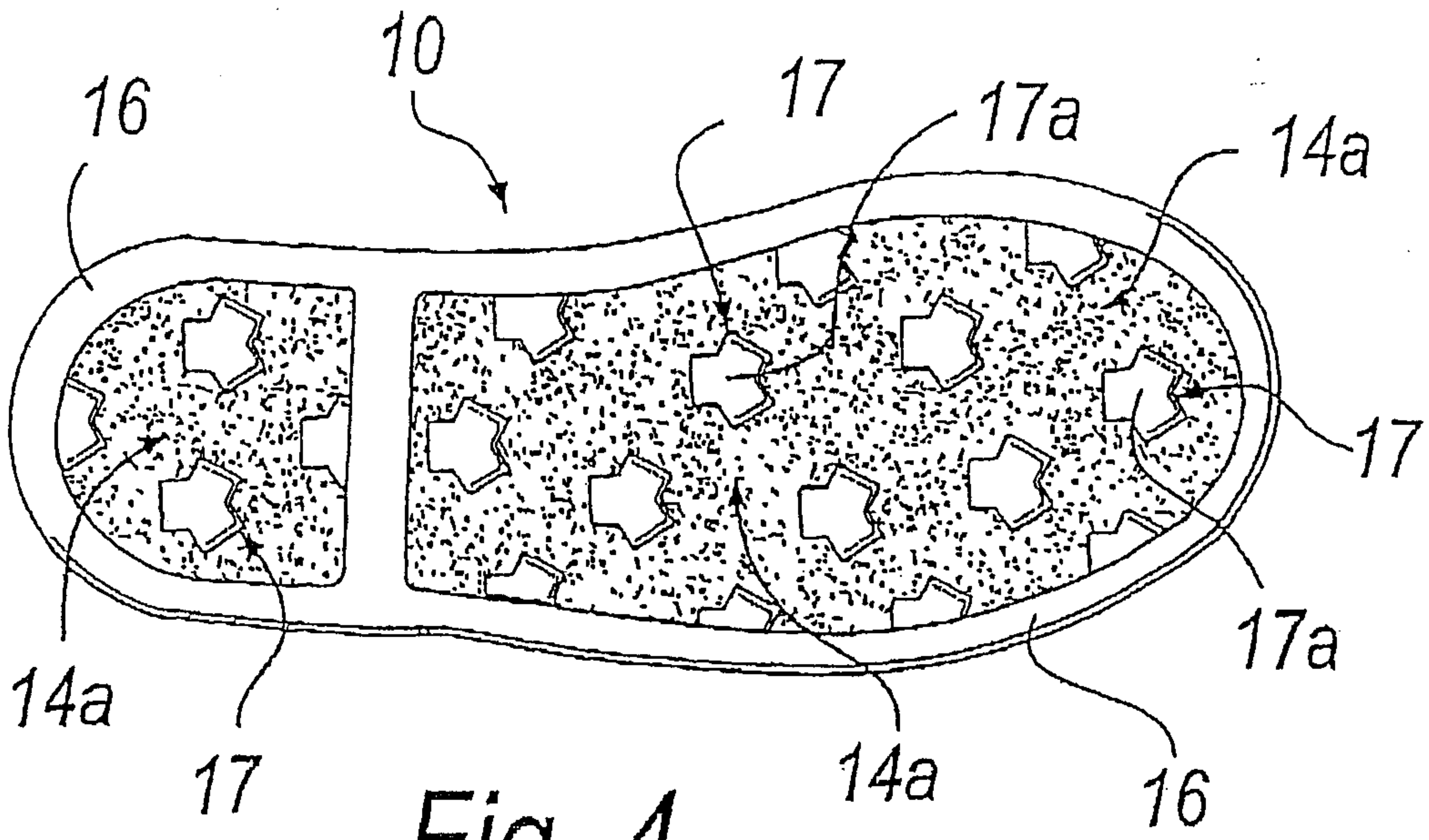

Fig. 4

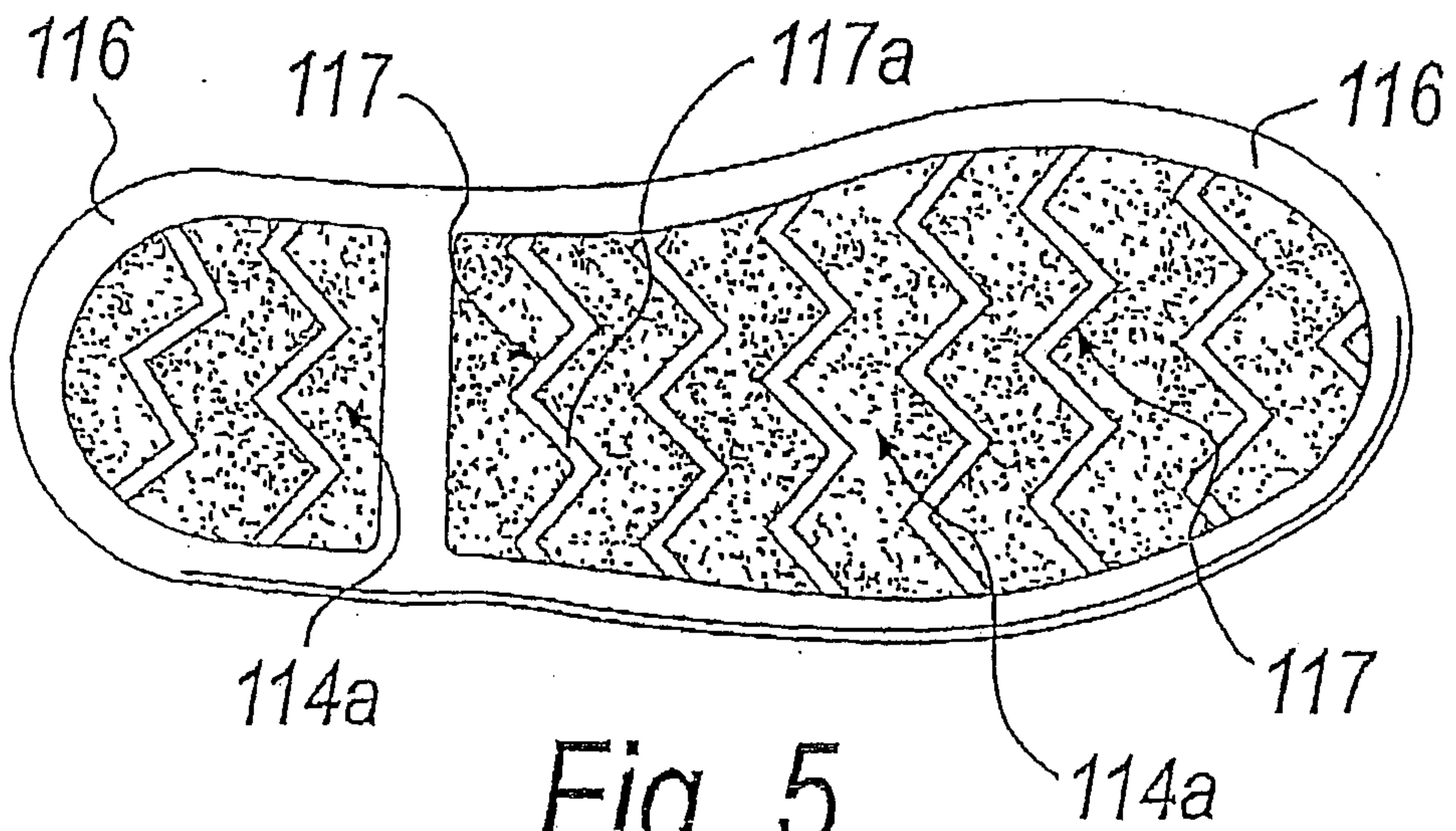

Fig. 5

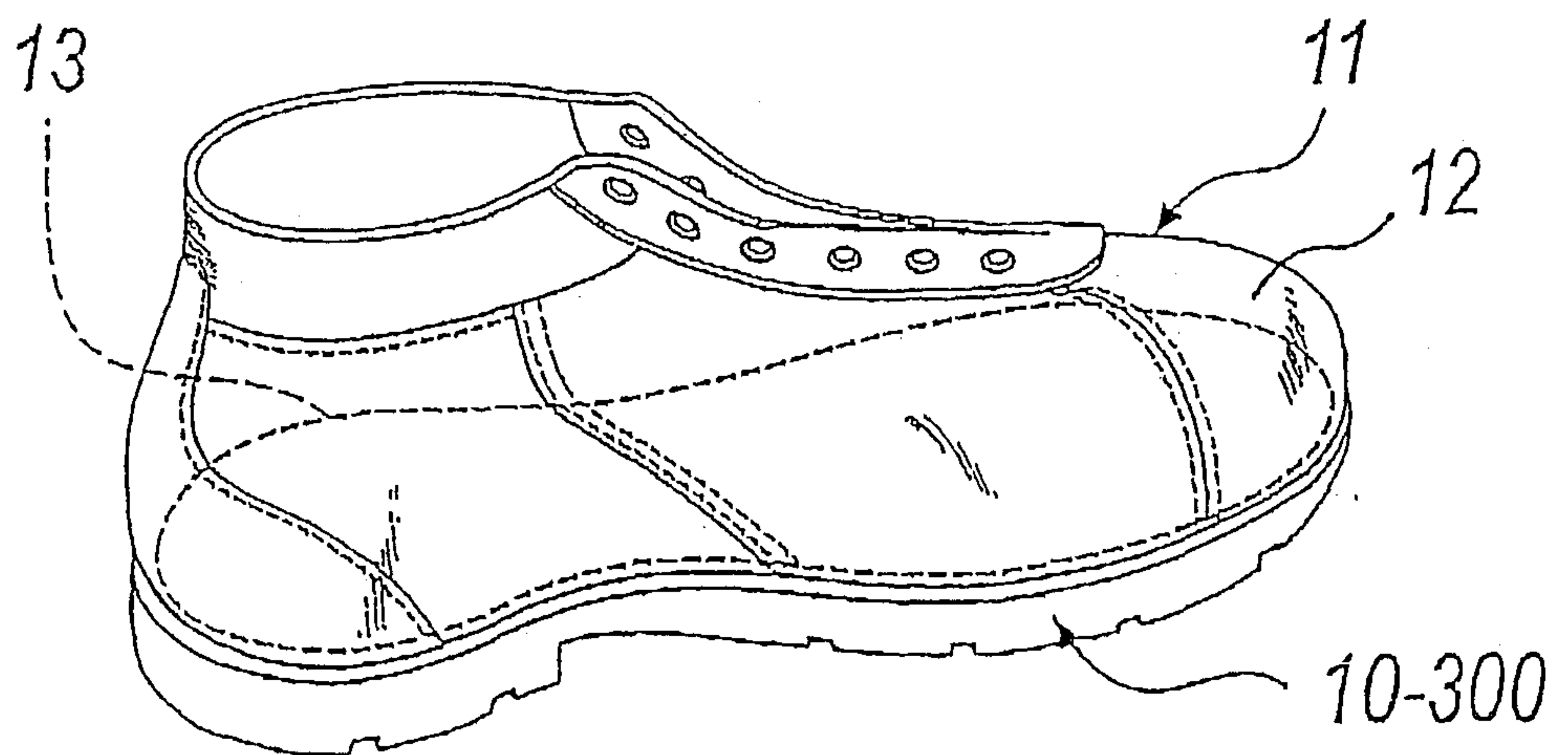

Fig. 7

3/4

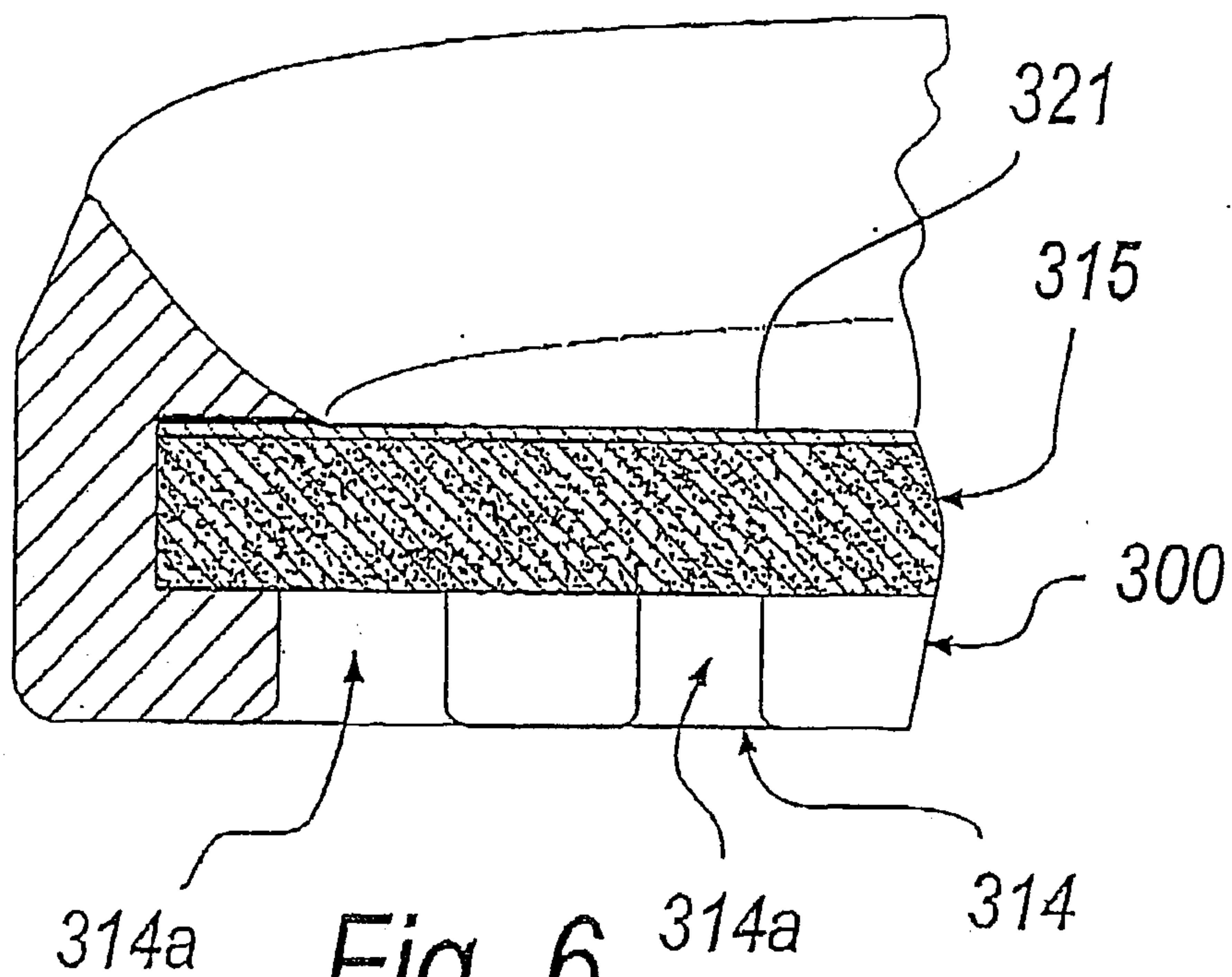

Fig. 6

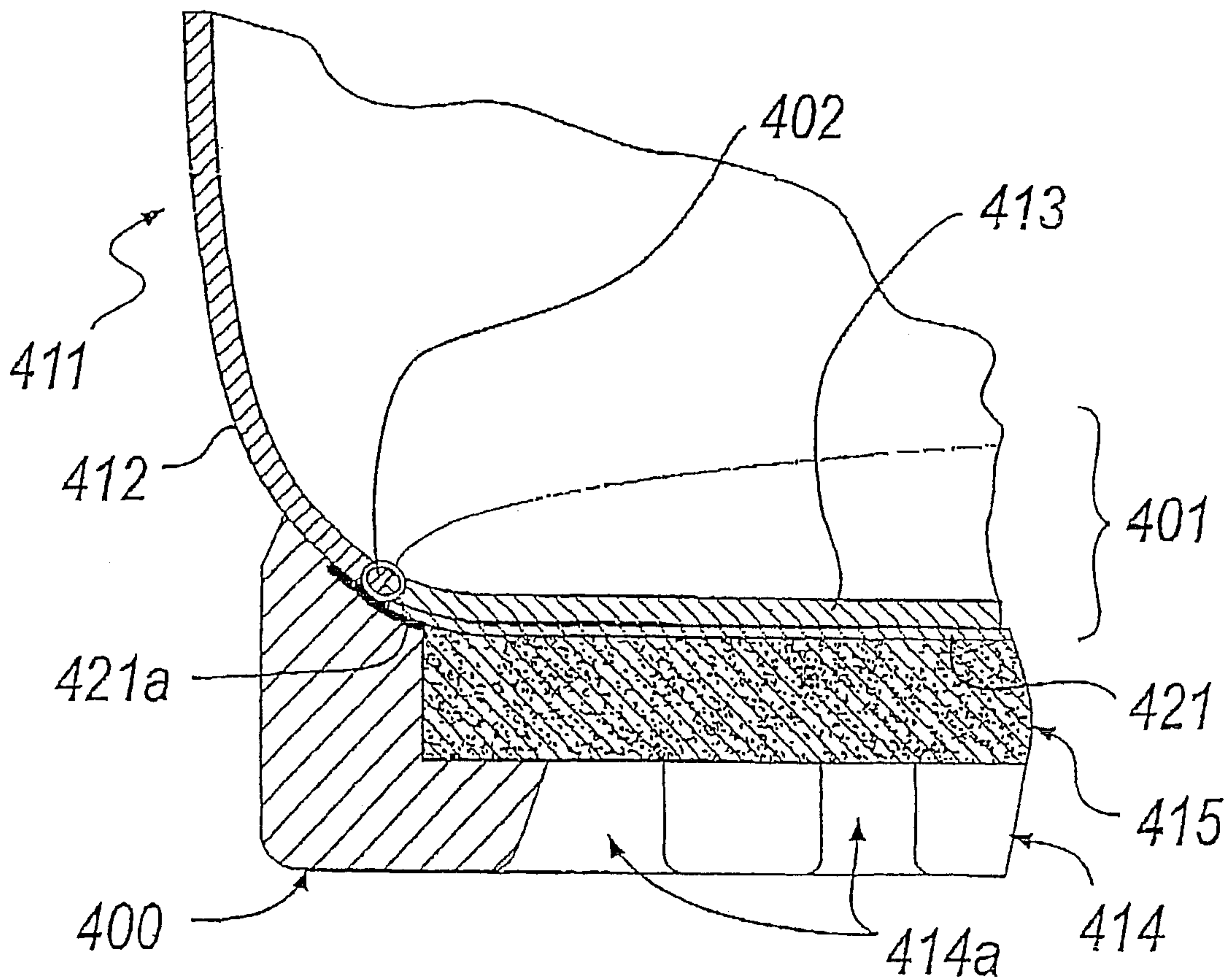

Fig. 8

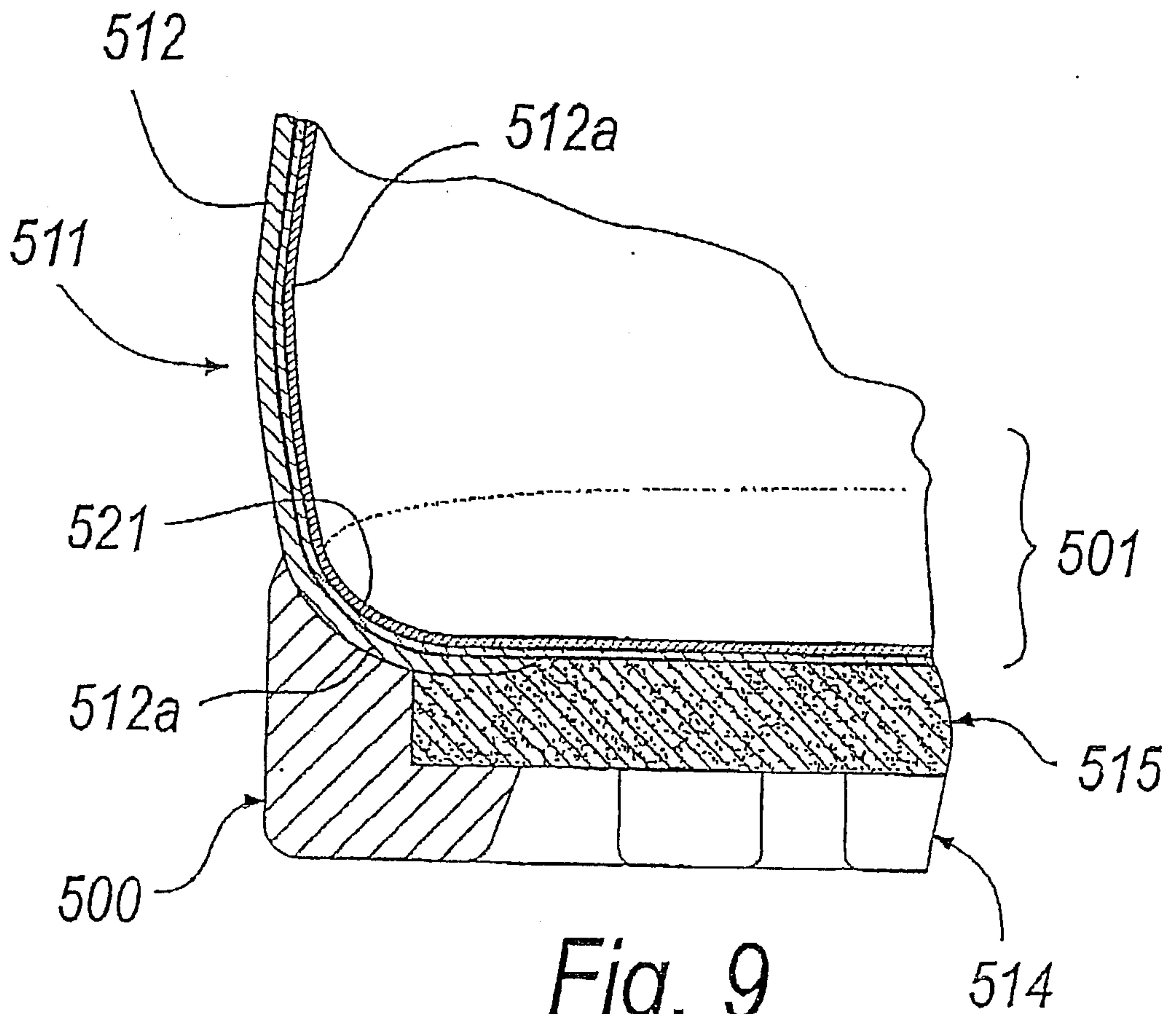

Fig. 9

