

April 18, 1961

C. B. WILLIAMS

2,980,131

TANK TEMPERATURE EQUALIZER

Filed July 20, 1959

FIG. 2.

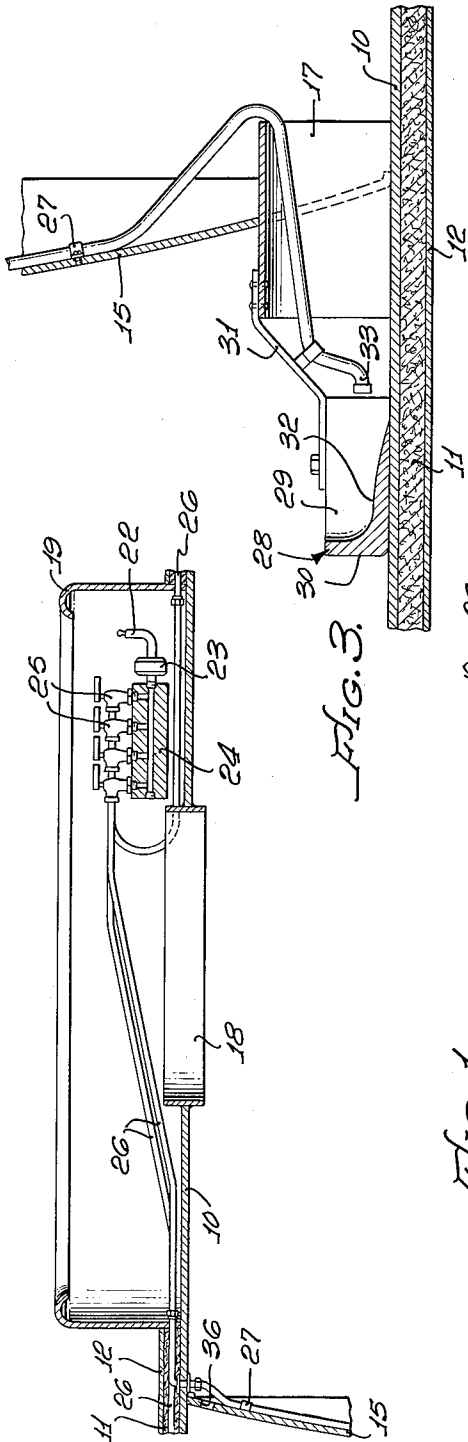
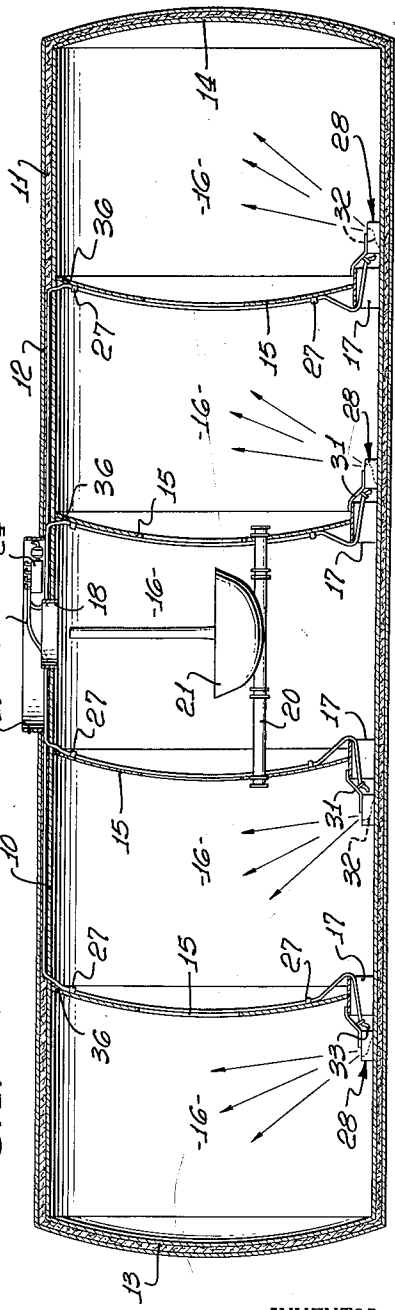

FIG. 3.

FIG. 1.



INVENTOR.
CHARLES B. WILLIAMS
BY
Hazard & Miller
ATTORNEYS.

1

2,980,131

TANK TEMPERATURE EQUALIZER

Charles B. Williams, 522 Santa Rosa Road,
Arcadia, Calif.

Filed July 20, 1959, Ser. No. 828,277

4 Claims. (Cl. 137—334)

This invention relates to improvements in tanks used on tank trucks and trailers for the purpose of conveying hot liquids.

Explanatory of the present invention, tank trucks and trailers are frequently used to transport hot liquids. Examples of such liquids and the temperatures at which they may be transported are:

Asphalt transported at approximately 450° F.;
Liquid coatings transported up to 525° F.;
Tallow transported up to 225° F.;
Hot waxes and fuel oils transported up to 200° F.; and
Edible and non-edible oils which are transported at temperatures up to 225° F.

The primary reason that such materials are transported in a heated condition is that such materials are either solid or semi-solid at ambient temperatures. Consequently, if such materials are heated to a temperature at which they are quite fluid they may be easily loaded as liquids into a tank and are normally expected to reach their destination while they are still heated and still liquid. When this occurs the tanks can be readily unloaded by merely permitting the heated liquid to drain therefrom or to be pumped therefrom.

In the interests of economy metal trucks are now being constructed of relatively thin steel or light weight metals, such as aluminum alloys, to reduce the mass of the tank structure that must be accelerated or decelerated in the course of transportation. Many jurisdictions also impose gross weight limits on transportable tank trucks and trailers, and consequently it is desirable to reduce the weight of the tank in the interests of increasing payload that may be transported within such gross weight limits. Usually, but not always, tanks of this general character are divided by baffles into voids which communicate with each other through the baffles near the bottom of the tank. These baffles also usually have crawl holes arranged adjacent the centers thereof and vent holes near the tops thereof. The baffles are intended to reduce excessive surging of liquid in the tank occasioned by quick deceleration of the tank truck or trailer.

Where hot liquids are being transported distortion problems arise in the course of filling the tank. Thus, when the hot liquid is introduced into the tank through the dome ring which is usually located over the center of the tank, the hot liquid descends to the bottom of the center void and flows therefrom through the drain holes in the bottoms of the baffles towards each end of the tank. Although the heat conductivity of the metal of the tank may be such as to quickly conduct heat to the top of the tank, there is nevertheless a certain time delay between bringing the bottom of the tank to approximately the temperature of the liquid and conducting sufficient heat to the top of the tank to bring the top of the tank to approximately the same temperature. Because of the quick heating of the bottom of the tank in advance of the heating of the top of the tank, the bottom of the tank expands in advance of the top of the tank. As a typical example, a

2

suitable aluminum alloy for tank construction has a coefficient of expansion of .0000132 foot per degree F. A typical or average tank length is twenty feet. If the ambient temperature is 50° F. and the liquid supplied to the tank has a temperature of 450° F. by computation the overall expansion of the bottom of the tank occasioned by raising its temperature from 50° F. to 450° F. is .10560 foot or 1.26720 inches. This expansion during the commencement of the filling operation is not experienced immediately by the top of the tank and stresses are set up in the tank structure of such a magnitude that the elastic limit of certain portions of the structure may become exceeded and a permanent deformation takes place. This manifests itself usually by the top of the tank sagging or becoming "sway-backed" intermediate its ends. The ultimate heating of the top of the tank brought about by the complete filling does not correct this deformation. Furthermore, the deformation frequently is cumulative. That is, after the tank has been once filled with hot liquid and a deformation has taken place, subsequent cooling of the tank on emptying it and re-heating of the tank on re-filling causes an addition or further deformation of the tank. This continued deformation may ultimately result in failure.

An object of the present invention is to provide an improved tank designed for use in the transportation of hot liquids wherein provision is made in each void of the tank for forcibly throwing incoming hot liquid that initially enters the void upwardly so as to contact the baffles and tank walls adjacent the top of the tank and thus promote uniformity in the heating of the tank with the hot liquid that initially enters it. By thus causing the top as well as the bottom of the tank to be heated by the initial incoming hot liquid, the expansion of the top is comparable with the expansion of the bottom and the creation of destructive deformation stresses is avoided.

With the foregoing and other objects in view, which will be made manifest in the following detailed description and specifically pointed out in the appended claims, reference is had to the accompanying drawing for an illustrative embodiment of the invention, wherein:

Fig. 1 is a vertical section through a tank embodying the present invention;

Fig. 2 is a partial view in vertical section through the structure associated with the dome ring of the tank; and

Fig. 3 is a partial view in vertical section of the liquid throwing means employed in each void of the tank.

Referring to the accompanying drawing wherein similar reference characters designate similar parts throughout, 10 indicates generally a metal tank of the character frequently employed on tank trucks and trailers. Where the tank is intended to convey hot liquids the metal skin of the tank is usually surrounded with heat insulating material indicated at 11 which, in turn, is covered with an outer sheathing indicated at 12.

The end 13 may be regarded as the forward head of the tank and 14 its rear head. Usually tanks of this character have within them dished baffles 15, the convex sides of which face forwardly. These baffles divide the interior of the tank into voids 16 which communicate with each other through drain holes in drain rings 17 that are located at the bottom of the baffles, through crawl holes near their centers, and vent holes near their tops.

The tank is usually filled by means of a hose and nozzle, not shown, that are introduced through a dome ring 18 that is surrounded by a overturn railguard 19. These rings are frequently located on the top of the tank adjacent its center.

In the center void 16 there is frequently supported on a conduit 20 a dome splash control 21, and after the liquid descends against this splash control it falls to the

3

bottom of the central void and then flows through the drain rings 17 to adjacent voids.

As above explained, if the liquid is hot the liquid which initially enters the tank on filling flows towards the end heads 13 and 14 of the tank and quickly heats the metal of the bottom of the tank to approximately the temperature of the liquid, expanding the bottom of the tank. Although heat is quickly conducted by the metal walls of the tank to the top of the tank, there is a time delay in bringing the top of the tank to the same temperature. The expansion of the bottom of the tank in advance of corresponding expansion of the top of the tank brings about deformation of the tank and may ultimately result in its failure.

In accordance with the present invention a coupling 22 is arranged within the dome ring 18 and is designed to have a compressed air source, not shown, connected thereto. The coupling leads to a pressure regulator 23 which, in turn, leads to a manifold 24 on which manually controlled valves 25 are located. Each valve has a tubing 26 connected thereto leading to its respective void 16. I prefer to arrange the tubing externally of the tank wall and within the insulation 11 and inside of the sheathing 12, but the exact arrangement of the tubing is of secondary importance insofar as the present invention is concerned. It is desirable to attach the tubing to the baffles 15 such as by brackets or the equivalent indicated at 27.

In each of the voids 16 with the possible exception of the central void and immediately adjacent the drain ring 17, there is what might be termed a type of venturi indicated at 28. This consists merely of a metal box having opposed side walls 29, a back wall 30, and an open front. It may be retained in position by means of bracket 31 which attaches it to the drain ring 17 and holds it adjacent the bottom of the tank. Its bottom indicated at 32 is so shaped as to define an upwardly directed passage into which hot liquid flowing through the drain ring 17 may flow. The tubing 26 terminates in a nozzle 33 that is directed into the upwardly turned or directed passage of the venturi.

On filling the tank with hot liquid the coupling 22 is connected to the source of compressed air and the valves 25 are left open. The hot liquid that initially enters the tank descends through the central void and starts flowing toward the ends of the tank. Some of this hot liquid enters the upwardly directed passages provided by the shaped bottoms 32. This hot liquid is subjected to the discharging stream of compressed air issuing from the adjacent nozzle 33 and is thrown upwardly with considerable velocity in the voids 16, thus contacting the top walls of the tank and the upper portions of the baffles and bringing these portions of the tank to approximately the same temperature as that to which the bottom of the tank is brought almost immediately. In this manner, uniformity in the heating of the tank is either accomplished or approximated, avoiding the objectionable distortion. As the tank continues to be filled and the liquid level rises the upwardly directed passages in the venturis will of course become submerged or "drowned" and when this occurs the coupling 22 is disconnected from the compressed air source. Air in the top of each void 16 returns through the vent holes 36 (see Fig. 2) and finds egress through the dome ring 18.

If the hot liquid is of such a character that it may form an explosive mixture if combined with air or sprayed thereby, an inert compressed gas may be used in lieu of the compressed air. Compressed air is preferable, however, when it can be used as it is usually available at loading docks where liquids of the type above referred to are frequently loaded.

On emptying the tank the valves 25 are left open to place the tubings 26 in communication with atmosphere and thus allow any liquid that may have risen in the

4

tubings 26 to drain therefrom. It is preferable also to have one valve 25 for each venturi. Prior to loading the tank each valve can be individually or separately opened and the remainder closed to release air through its respective tubing. The discharge of air through any single tubing can ordinarily be heard and may thus serve to indicate that the selected tubing has not become clogged and is ready to perform its function of throwing the hot liquid which initially enters a void in the tank upwardly against the top walls thereof.

It will be appreciated from the above-described construction that the apparatus for throwing the hot liquid upwardly in the voids of the tank is relatively simple and can be easily and quickly installed, and that it has no moving parts within the tank to require any maintenance or repair. By thus promoting uniform heating of the tank with that portion of the liquid which initially enters the tank unequal expansion between the top and bottom of the tank is avoided.

While the invention has been primarily designed for use in portable tanks divided into voids by baffles, it will be appreciated that it is not restricted thereto and that it may be employed with similar advantages in tanks which are not equipped with baffles.

Various changes may be made in the details of construction without departing from the spirit and scope of the invention as defined by the appended claims.

I claim:

1. In combination, an elongated tank for use in the conveyance of hot liquids which tank is divided by transversely extending baffles into voids which communicate with each other through the baffles, means for introducing hot liquid to be conveyed into one of the voids from which it may flow into the other voids, and gas actuated means adjacent the bottom of each of said other voids for throwing the liquid initially entering the said other voids upwardly so as to contact and heat the baffles and skin of the tank adjacent the top thereof, thus causing the baffles and skin to be heated by the liquid initially entering each of said other voids approximately uniformly in the course of filling the tank.

2. In combination, an elongated portable tank for use in the conveyance of hot liquids divided by transversely extending baffles into voids which communicate with each other through the baffles, means for introducing hot liquid to be conveyed into one of the voids from which it may flow into the other voids, means defining an upwardly turned passage in each of said other voids into which the hot liquid initially entering the said other voids may flow, and means for discharging a compressed gas into each of said passages to cause hot liquid which initially enters the said passages to be thrown upwardly to contact the baffles and walls of the tank adjacent the top thereof and thus tend to equalize heating of the tank by the hot liquid which initially enters the tank in the course of filling the tank.

3. In combination, an elongated portable tank for use in the conveyance of hot liquids divided by transversely extending baffles into voids which communicate with each other through the baffles, means for introducing hot liquid to be conveyed into one of the voids from which it may flow into the other voids, means defining an upwardly turned passage in each of said other voids into which the hot liquid initially entering the said other voids may flow, and means for discharging a compressed gas into each of said passages to cause hot liquid which initially enters the said passages to be thrown upwardly to contact the baffles and walls of the tank adjacent the top thereof and thus tend to equalize heating of the tank by the hot liquid which initially enters the tank in the course of filling the tank, the gas supplied to each of said other voids being individually valve-controlled.

4. A portable tank for use in the conveyance of hot liquids comprising an elongated tank divided by trans-

5

versely extending baffles into voids which communicate with each other through the baffles adjacent the bottom thereof, means for introducing a hot liquid to be conveyed into one of the voids from which it may flow into the other voids, means defining an upwardly directed passage in each of said other voids into which hot liquid initially entering the tank may flow, and a valve-controlled conduit leading to each passage in each of said other voids for discharging a compressed gas therein to

6

throw hot liquid entering the passage upwardly for the purpose of promoting uniform heating of the tank.

References Cited in the file of this patent

UNITED STATES PATENTS

1,751,719	Uhri -----	Mar. 25, 1930
2,301,601	Wittwer et al. -----	Nov. 10, 1942
2,480,472	Jackson -----	Aug. 30, 1949
2,689,461	Brandon -----	Sept. 21, 1954