

G. W. WILSON.

Furnace.

No. 44,246.

Patented Sept. 13, 1864.

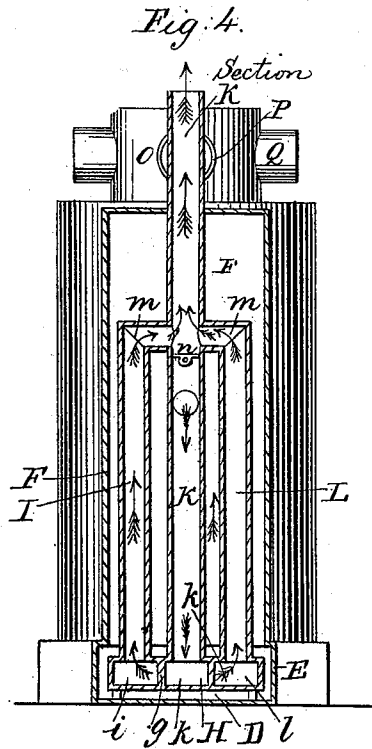
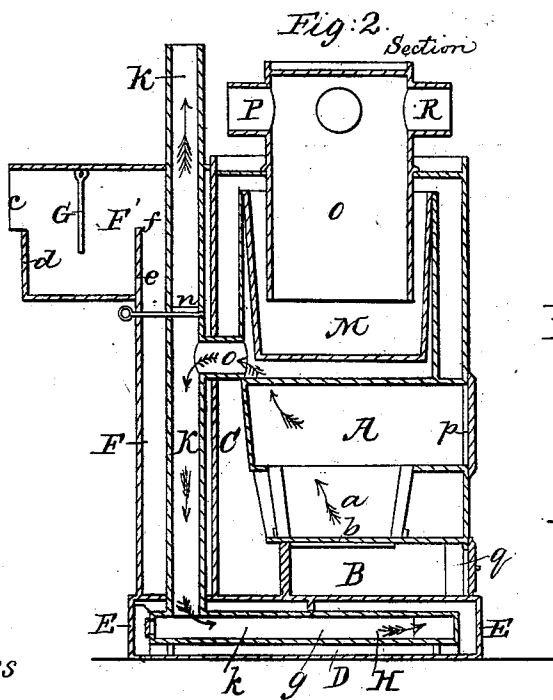
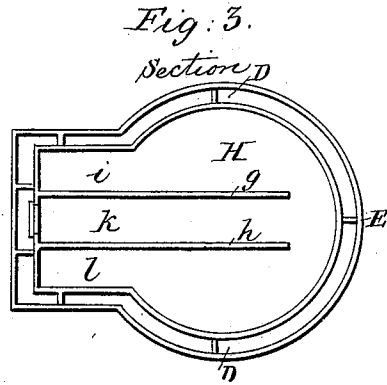
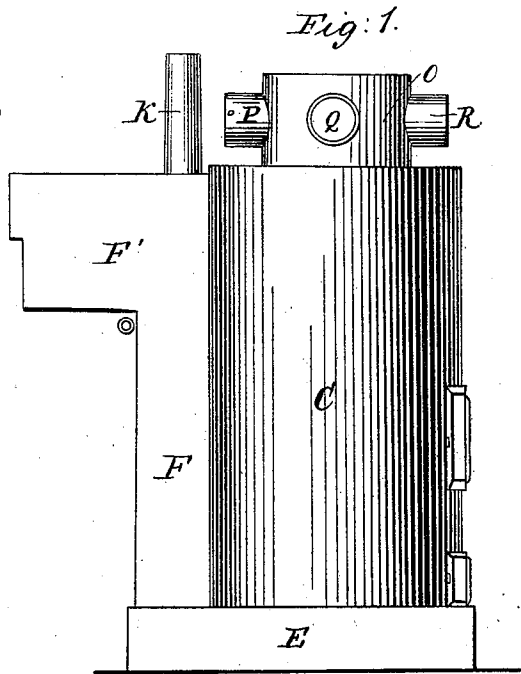

Witnesses
C. P. Hale Jr.
Frederick Curtis

Inventor
G. W. Wilson
by his attorney
D. R. Theobald

UNITED STATES PATENT OFFICE.

GEORGE W. WILSON, OF CHELSEA, MASSACHUSETTS.

IMPROVED FURNACE-HEATER.

Specification forming part of Letters Patent No. 44,216, dated September 13, 1864.

To all whom it may concern:

Be it known that I, GEORGE W. WILSON, a resident of Chelsea, in the county of Suffolk and State of Massachusetts, have invented an Improved Air-Heating Apparatus or Furnace; and I do hereby declare the same to be fully described in the following specification and represented in the accompanying drawings, of which—

Figure 1 is a side elevation, and Fig. 2 a vertical section, of it. Fig. 3 is a horizontal section taken through its base flue-chamber and the air-chamber around it. Fig. 4 is a vertical and transverse section taken through the three flue-pipes erected on the flue-chamber.

In the said drawings, and particularly in Fig. 2, A denotes a fire-chamber, of which *a* is the space for the fuel, while *b* is the grate, and B an ash-chamber. An air-heating chamber, C, surrounds the said fire-chamber and ash-chamber and opens at bottom into a hollow chamber, D, made in the base E of the apparatus. A vertical passage, F, opening at the bottom into the chamber D, is erected on the base E and in rear of the air-chamber C. The upper part of the conduit F is provided with an elbow, F', which runs backward horizontally, and has an air entrance or opening, *e*, situated over a vertical partition or flange, *d*. In advance of the flange *d* is another such partition or flange, *e*, over which there is a free air-passage, *f*. Within the elbow F' there is a pendulous flap or plate, G, which at its top is hinged to the elbow F', and so as to be capable of swinging toward and against, or nearly against, each of the flanges *d e*. Furthermore, there is a shallow smoke flue chamber or case, H, placed within the base chamber D, and arranged so that air, while circulating within the chamber D, may pass freely in contact with the external surfaces of the top, bottom, and sides of the case H. This case or chamber H is furnished with two partitions, *g h*, which extend from its rear part forward, parallel to one another, and from top to bottom of the said chamber H, and terminate within a short distance of its front in manner as shown in Figs. 2 and 3. The said partitions divide the chamber H into three flues, *i k l*. At the rear ends of these three flues are three vertical pipes, I K L, which rise upward within the air-duct F. The middle one, K, of these pipes opens out of the flue *k* of the case

H, and runs out of and beyond the upper part of the duct F. The pipes I L lead, respectively, out of the flues *i l* and into the pipe K by elbows, as shown at *m n* in Fig. 4, there being a damper, *n*, in the pipe K and just below the said elbows. A short pipe, *o*, leads from the fire-chamber A into the pipe K and below the damper *n*. The throats of the fire and ash chambers are represented at *p* and *q*, they being made to open from their chambers through the case *c*, and to have doors, as in other furnaces. Furthermore, there is a sunken air space or vessel, M, arranged within the fire-chamber A in manner as shown in Fig. 2, the said space or vessel M being open at top and closed at bottom and concentric with the fire-chamber. There also projects through the top plate, N, of the case C an inverted drum, O, which is closed at top and open at bottom, and projects into the space or vessel M in manner as shown in Fig. 2. One or more air ducts or pipes, P Q R, may lead out of the upper portion of the drum O, and so as to convey the heated air received therein to such apartments as it may be desirable to transfer it.

The operation of this furnace may be thus described: The smoke and volatile products of combustion from the fire-place, after acting against and heating the outer surface of the vessel M, escape from the fire-place through the pipe *o*, and, provided the damper *n* be closed, pass down the pipe K and enter the flue *k*. After coursing through the flue *k* the said smoke and volatile products of combustion divide and pass into the two flues *i l*, and go through them and into and through the pipes I L and the elbows at their upper ends, and from thence into that part of the pipe K which is above the damper *n*, from whence they escape into the atmosphere.

In going through the several flues and pipes, as above described, the smoke and heated volatile products will impart heat to them, and such heat will be radiated into the air-spaces surrounding such pipes and flues. The cold or atmospheric air to be warmed enters the opening *e* of the elbow F' and flows against and underneath the pendulous valve or flap G, and through the passage *f*, thence down the duct F, thence into the base-chamber D, thence into the chamber or case C, thence into and down the vessel M, and up into the

drum *o*, from whence it escapes by the pipes P Q R, the said air in the mean time receiving heat from the heating surface of the fire-place and flues, as specified. Should the in-rush of air into the duct F be too rapid for the proper heating of the air while it may be passing through the air-heating chambers of the furnace, such air, by impinging against the pendulous valve G, will swing it more or less toward the flange *e*, and thus interrupt the rush of air through the opening *f*. So, should there be any tendency of the hot air to escape from any cause through the passage *c*, the valve G will be swung by the current toward the flange *d*, so as to close the passage *c* and prevent the escape of the air, it being understood that the valve G is properly made so as to operate as described. Furthermore, when the damper *n* is open, the smoke will pass off directly up the pipe K, instead of first going down the same and into the case H.

Having thus described my improved air-heating furnace, what I claim thereof as of my invention is as follows:

1. The combination of the flue-chamber H (having flues *i k l*, as described) and the three

pipes I K L (connected and provided with a damper, as explained) with the fire-chamber A.

2. The combination and arrangement of the flue-chamber H and the pipes I K L, the air-duct F, the base-chamber D, the air-chamber C, and the fire place or chamber A, the whole being constructed and applied, and so as to operate together substantially as specified.

3. The combination and arrangement of the fire-place A, the air-chamber C, the vessel M, and the distributing-drum O.

4. The combination and arrangement of the fire-place A, the vessel M, the drum O, the air-chamber C, the base chamber D, the air-duct F, the smoke-chamber H, and the smoke-pipes I K L, the whole being applied and connected together substantially as described.

5. In combination with the air-duct F of the air-heating furnace, the vibrating valve G, flanges *d e*, and openings *c f*, the whole being to operate in manner and for the purpose substantially as specified.

GEO. W. WILSON.

Witnesses:

F. P. HALE, Jr.,

C. H. BEAN.