

Conant & Thompson,

Spike Lathe.

No. 100,261.

Patented Mar. 1. 1870.

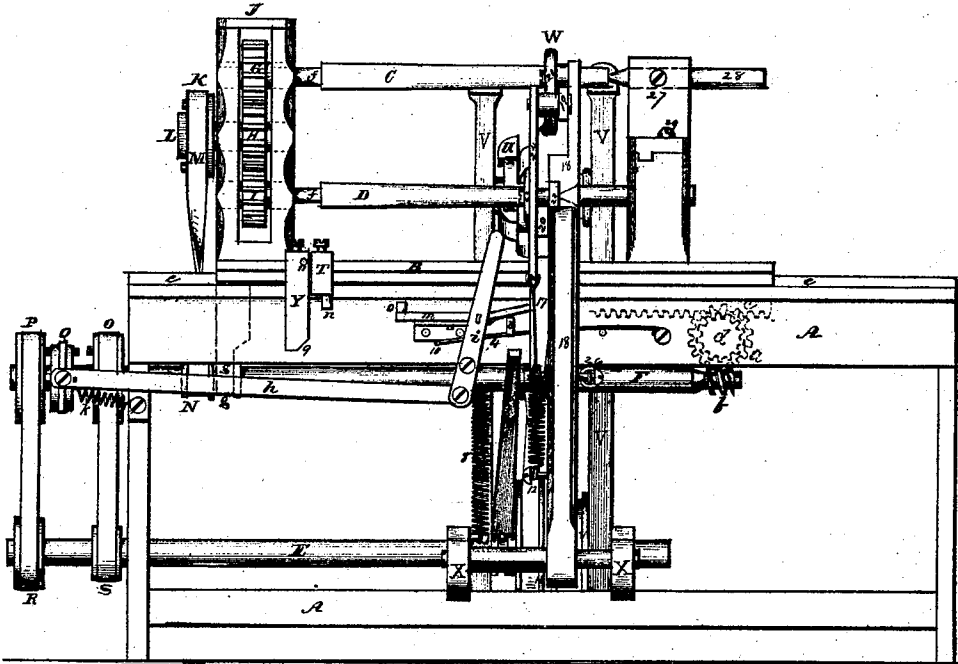
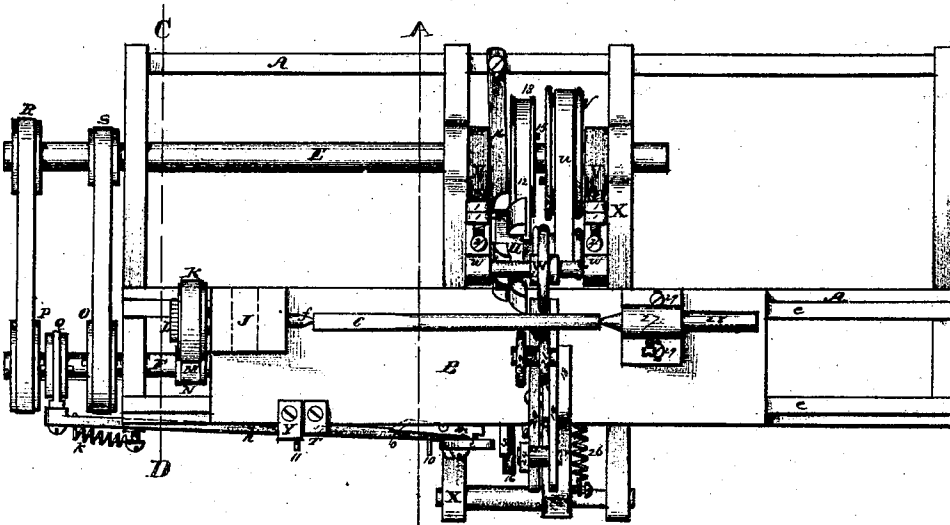

Fig. 1



B Fig. 2

Witnesses
 Thos. B. Dodge
 Chas. W. Paulding

Inventors
 C. B. Conant
 H. Thompson

Conant & Thompson, *2. Sheets. Sheet 2.*

Stroke Lathe

No. 100251.

Patented Mar. 1. 1870.

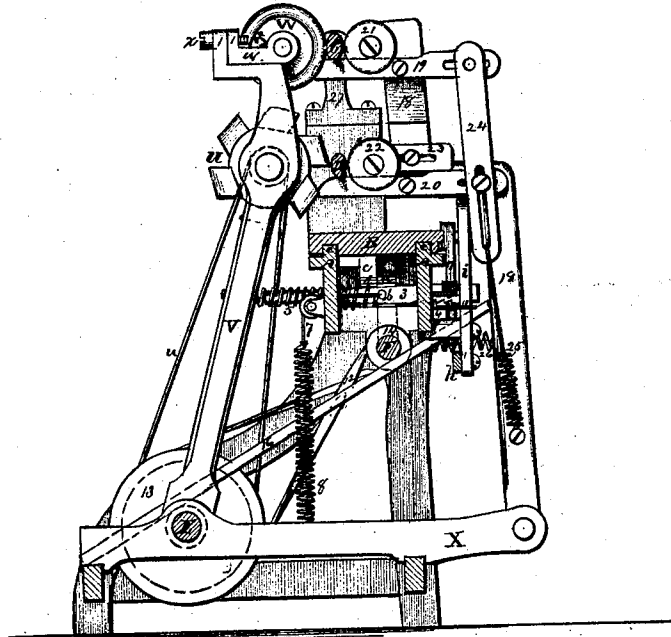

Fig. 3

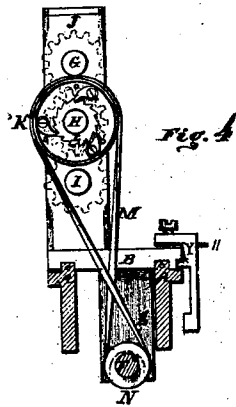

Fig. 4

Witnesses

Thos. H. Dodge
Chas. S. Burleigh

Inventors

C. B. Conant
H. Thompson

United States Patent Office.

CHARLES B. CONANT AND HIRAM THOMPSON, OF WORCESTER, MASSACHUSETTS.

Letters Patent No. 100,261, dated March 1, 1870.

IMPROVEMENT IN SPOKE-LATHE.

The Schedule referred to in these Letters Patent and making part of the same.

To all whom it may concern:

Be it known that we, CHARLES B. CONANT and HIRAM THOMPSON, of the city and county of Worcester, and Commonwealth of Massachusetts, have invented certain new and useful Improvements in Spoke-Lathes; and we do hereby declare that the following is a full, clear, and exact description of the same, reference being had to the accompanying drawings forming a part of this specification, in which—

Figure 1 represents a front view of our improved spoke-lathe;

Figure 2 represents a plan view of the same;

Figure 3 represents a transverse section on line A B, fig. 2; and

Figure 4 represents a transverse section of the upper part, at line C D, fig. 2.

To enable those skilled in the art to which our invention belongs to make and use the same, we will proceed to describe it more in detail.

The nature of our invention consists—

First, in the combination of certain devices for automatically reducing the speed of the pattern and spoke-blank after the round part of the spoke has been turned, as hereafter explained.

Second, in the combination of certain devices in a spoke-lathe, whereby the carriage can be run back very quickly while the pattern and finished spoke remain at rest, as hereafter explained.

Third, in the combination with the frame which supports the cutter-head and guide-wheel, of mechanism for automatically throwing back said frame as soon as the spoke is finished, as hereafter described.

Fourth, in the combination of certain devices for supporting and steadying the spoke and pattern in a peculiar manner during the operation of turning, as hereafter explained.

Fifth, in a laterally adjustable stand for supporting one end of the pattern, substantially as and for the purposes hereafter explained.

In the drawings, the part marked A represents the main frame, on which is mounted the carriage B that supports the pattern C and spoke-blank D.

The main shaft E is arranged at the lower rear part of the frame A, and a carriage-shaft, F, is arranged parallel thereto, in the upper part of said frame A.

The carriage-shaft F is provided with a screw or worm, b, at its end, which works in a worm-gear, a, beneath the carriage B, and upon the under side of said carriage B is secured a rack, c, which meshes into a pinion, d, secured to the same shaft as the worm-gear a, as shown in figs. 1 and 3.

The carriage is supported on and guided by ways e on the top of the main frame A.

The chucks f, which hold the pattern and the spoke-blank, are connected for operation by three gears, G, H, and I, in the lathe-head J. The gear G, which turns the pattern C, and the gear I, which turns the spoke blank, are both of the same size, so that both will turn alike. The gear H, from which the two former derive their motion, may be made of any size desired.

The shaft of gear H extends to the outside of the head J, and is provided with an operating-pulley, K, hung loosely on said shaft, and a ratchet-wheel, L, which is secured firmly to said shaft.

To the side of pulley K are pivoted pawls which engage with the ratchet-wheel L when the carriage is run forward, and thereby turns the gear H, and when the carriage is run back the pawls pass over the ratchet-teeth, and the gear H and parts connected therewith remain at rest. By this arrangement the motion of the spoke and pattern is stopped during the backward movement of the carriage B.

The pulley K is operated by a belt, M, from a pulley, N, on the carriage-shaft F.

The pulley N is arranged to move along the shaft F as the carriage is run to the right or left by the action of an arm, g, that projects downward from the under side of the carriage B and fits into a groove formed around the hub of pulley N.

The pulley N is prevented from turning on the shaft F by means of a spline, which travels in a longitudinal groove in the side of said shaft.

The shaft F is provided at its end with two loose pulleys, O and P, between which works the clutch Q. The clutch is so arranged that it can engage with either of the pulleys O and P, (which are furnished with clutch-teeth on their sides,) or it may be placed in an intermediate position so as not to engage with either.

The pulley P is driven by a belt from the pulley R and the main shaft E, and pulley O is driven in like manner from another pulley, S, on said shaft.

The pulley S is smaller than pulley R, so that when the clutch Q engages the pulley P, the speed of the carriage-shaft F is greater than when the clutch Q is in mesh with pulley O.

The clutch Q is connected by a bar, h, to the lower end of the shipper-lever i, pivoted upon the front of the main frame A, and a spring, k, is attached to the bar h, the action of which tends to draw the clutch toward the pulley O, with which it will clutch whenever the spring k is allowed free action.

A trip-lever, m, is arranged just back of the shipper-lever i, upon which the latter is caught and held when the clutch Q is thrown outward against the pul-

ley P, and an adjustable tripping-dog, T, is secured to the front of the carriage B for operating the trip-lever *m*, which it does by passing its beveled point *n* behind the beveled point *o*, on the lever *m*, as the carriage moves forward, and thereby swinging back its latch-end and releasing the shipper-lever *i*.

The trip-dog T is adjusted so that it will trip the lever *m* when the lathe has turned the round part of the spoke; and the spring *k*, as soon as the shipper-lever *i* is released, throws the clutch Q across to the pulley O, which pulley turns the shaft slower than pulley F, so that the carriage B will be moved forward with less velocity, and the pattern and blank turned with less speed during the remaining distance or while the flat part of the spoke is being turned.

The cutter-head U is supported on the upright swinging frame V, which frame also supports the guide-wheel W. The arbor upon which the cutter-head is hung is provided with a suitable pulley, and driven by a belt, *u*, from a pulley, *v*, on the main shaft E.

The bearings *w*, which support the arbor of the guide-wheel W, are made adjustable on the upright frame V by means of set-screws *x* that pass through the upright flanges 1, and they can be held firmly in any adjusted position by the clamp screws 2, which are arranged in slots formed for their reception, as indicated in the drawings.

The frame V is drawn forward into working position, as shown in the drawings, by a latch-bar, 3, and spring, 5; spring 5 being fastened to the frame V while the bar extends through to the front of the main frame A, where it is held by the spring 4, which catches into one of the notches formed on the under side of said bar 3. The rear end of bar 3 works in the spiral spring 5, the outer end of which spring is fastened to the upright swinging frame V, while the other end of spring 5 is secured to the bar 3 by a pin, 6, or an adjustable collar may be used for that purpose, whereby the tension of spring 5 may be increased at pleasure to vary the pressure of the guide-wheel upon the pattern.

One end of a cord, strap, or chain, 7, is fastened to the bar 3, while the other end is secured to the upper end of a spring, 8, the lower end of said spring being fastened to one of the cross-pieces X. The spring 8 is employed to draw the bar 3 back as soon as its front end is released by the depression of spring 4, which is effected by the beveled or inclined part 9 of the shipping dog Y on carriage B, striking against the projecting or bent end 10 of spring 4, as soon as the carriage B has moved far enough forward to complete the turning of the spoke or other article.

As bar 3 is drawn back its rear end passes through the spiral spring 5 and strikes against the upright swinging frame V and forces that back, together with the cutter-head U and guide-wheel W, clear of the pattern and turned spoke, the distance being sufficient to enable the operator to remove the turned spoke and insert a blank without danger or liability of being caught by the cutters which remain in motion.

A pin or stud, 11, projects from the upper part of the shipping-dog Y, which strikes the shipper-lever *t* as the carriage moves forward, and immediately after the cutter-head is thrown back the clutch Q is thereby carried to a central position between the pulleys O and P, when the motion of the carriage-shaft will cease.

The shipper-lever *t* catches upon a small notch on the trip-lever *m*, and holds the clutch Q in a central position while the carriage is being run back, which operation is performed by giving a reverse motion to the carriage-shaft F by means of a crossed belt, 12, from a pulley, 13, on the main shaft E, which runs on a small pulley, 14, on the shaft F, as indicated in fig. 3 of the drawings.

The pulley 13 is hung loosely on the main shaft, and is connected therewith for operation by a suitable clutch, 15, which can be thrown in and out by a lever, 16, that

extends obliquely upward to the front of the machine.

A dog, 17, is arranged on the front of the carriage B, for shifting the lever 16 and throwing out the clutch 15 when the carriage has run sufficiently far back. The pulley 13 is made much larger than the pulley 14, so that the carriage B is run back very quick.

The devices for supporting and steadying the pattern and spoke-blank against the action of the guide-wheel and cutters consist of an upright swinging frame, 18, upon which are arranged two supporting levers, 19 and 20, and two steadying-wheels, 21 and 22.

The wheel 21 is arranged on the frame 18, in such positions that it will press upon the pattern directly opposite to the guide-wheel W, while the wheel 22 is attached to an adjustable slide, 23, and adjusted to press upon the spoke directly opposite to the finishing cutters.

The front ends of the supporting-levers are joined together by the connecting-rod 24, suitable slots being formed at the points of connection so that the rod 24 can be adjusted to give uniform or unequal motions to the rear ends of said levers, as occasion may require, especially when turning spokes different in size and taper to the pattern.

The levers 19 and 20 are held up against the under side of pattern and spoke by means of a spring, 25, one end of which is attached to the frame 18, and the other end to the lower end of the connecting-rod 24, upon which it acts with its contractive force.

The frame 18 is drawn back to press the rolls 21 and 22 against the pattern and spoke by means of a spring, 26, one end of which is attached to the main frame A and the other to the frame 18, as indicated in the drawings. It will be observed that the swing frames V and 18 are both pivoted in nearly the same horizontal plane.

The bearing 27 that supports the spindle 28, on which the pattern runs, is made adjustable laterally, so that spokes of different taper can be turned from the same pattern. Clamp-screws 29 are arranged in slots formed through the base of the bearing, whereby it can be held in any adjustable position.

In lieu of the springs K, 8, 25, and 26, cords and weights may be substituted therefor if preferred.

The operation is as follows:

The spoke-blank is secured in position in the lathe, and the operator draws forward the swing frame V by means of the bar 3, which is caught upon the spring 4 and held while the cutters are in working position.

The operator then carries the top of the shipper-lever *i* to the right and latches it upon the end of the trip-lever *m*. This movement throws the clutch Q into action with pulley P, and the carriage B is thereby set in motion, which carries the blank to the right past the cutter-head U, while the pattern O and blank D are rapidly revolved until the round part of the spoke is turned, at which time the dog T trips the lever *m*, and the clutch Q is, by the spring *k*, thrown into action with the pulley O, thereby reducing the speed of the shaft F, so that while the flattened part of the spoke is being turned the carriage moves slower and the pattern and blank revolve less rapidly.

When the spoke is turned the dog Y throws down the spring 4 to release the bar 3, and the swing frame V is thrown back by spring 8, carrying the cutters out of the way, and at the same time the motion of the carriage is stopped by the pin 11, which, striking the shipper-lever *i*, throws the clutch Q out of action, as before described. The operator then carries the end of lever 16 to the right, which throws in the clutch 15, and the carriage is quickly run back by the action of belt 12 until the dog 17, striking against the end of lever 16, throws out the clutch 15, thereby stopping the motion of the carriage. The operator can then remove the finished spoke and replace it with a new blank, and repeat the operation.

Having described our improved spoke-lathe,
What we claim therein as new and of our invention,
and desire to secure by Letters Patent, is—

1. The combination with the shafts E and F, pulleys O P R S, and their belts, as shown and described, of the shipper-bar *h*, spring *k*, and double clutch Q, as and for the purposes set forth.

2. The combination with the shipper-lever *i* of the tripping-lever *m*, substantially as and for the purposes set forth.

3. The combination of carriage B and dog T with tripping-lever *m* and lever *i*, substantially as and for the purposes set forth.

4. The combination with carriage B and shipper-lever *i* of the dog Y, provided with a stop-pin 11, substantially as and for the purposes set forth.

5. The combination with the gears G H I of the loose operating pulley K, provided with a pawl or pawls and ratchet-wheel L, said parts being arranged in relation to each other as and for the purposes described.

6. The combination with the swinging frame V of the bar 3 and spring 8, substantially as and for the purposes set forth.

7. The combination with the swinging frame V and bar 3 of spring 5, substantially as and for the purposes set forth.

8. The combination with bar 3 and spring 4 of the dog Y, substantially as and for the purposes set forth.

9. The relative arrangement of the hinged frames V and 18, having their pivots or axes of oscillation in the same horizontal plane, substantially as and for the purposes set forth.

10. The combination with the hinged frame V, and its cutter-head U and guide-wheel W, of the hinged frame 18 and its supporting and steadying-wheels 21 and 22, as and for the purposes set forth.

11. The combination with frame 18 of the supporting levers 19 and 20, adjustable connecting-rod 24, and spring 25, arranged substantially as and for the purposes set forth.

12. The combination with the laterally-adjustable stand 27 and center 28, herein described, for supporting one end of the pattern, of the hinged frame 18 and adjustable devices which it carries for supporting the pattern and blank spoke against the action of the cutters and guide-wheel, substantially as described.

13. The combination with the upper end of the frame V and journal of the guide-wheel W of the set-screw *x*, upright flanges 1, and clamp-screws 2, as and for the purposes described.

C. B. CONANT,
H. THOMPSON.

Witnesses:

THOS. H. DODGE,
CHAS. H. BURLEIGH.