

가
(aerial images)

가

6

() / (reticle)
() ()
(resist)

가

가 (feature)

가

가

가 (Levenson type)

180° 가

가

(attenuated or half-tone)

가

4% - 30%

180°
(aerial image measurement equipment)

0) (16) (14) , (18) - (2)

2 (14) (14) (18) - , (16)() (20) (22,24), (23,25)

가 (28) (26)

3 (18) (28) , - (20)

(26) (50) (10) , (18)

) (32,34) - (20) (3)

6) 8 (30)() , - (36)

(20) (36) (20)

37,38,39,40) (36) - (36) (36)

가 (20) (36) (20)

- (20) (36) (20)

- (36) (36) (20)

ethod) (41) (36) (20) (36) (subtractive m

가 (36) (20) (37/22, 38/23, 39/24, 40/25)

가 가 , , -

7 (10) 가 , (14) (10)

0 가 , (22) (36) (37) ,

가 0° (41)() 가 가

(12) 가 가 , 가 , (null point)

(39) 가 가 , , (20) (24)

가 가 0° (41) (14)

가 - 가 0 (20) (22)

(36) (37) 가 , , 7

X- (22,37) 가 y-

(38) - (23) 가

y- , 가

remement esuipment) 가 가 (aerial image measu

(Carl Zeiss, Inc., , Thornwood) MSM

(100) 7 (32,34)

가 , 가

가 (aerial ima

ges) , ,

(22) 9-11 가 (36) (37) 'a' 8 (20) (41)

(36) 9 11 (20a) (41)

(41a) (30) (36a) (20) (20a) (12)

(20a) (36a) (47) (47,43,44,45) (36a) (20a) 10

12 가 'b' 가 (10b) (49)

(49) (48) (49,50) (50)

)가 X-

가 (가 ; additive method) 가 가 13 14

) 'c' 가 가 (20c) (36c)

15 16 가 'd' 가 9-11

(41d) (36d) (20d)

(62) 17-19 (60) 17 (64)

(18) (64)

(66) (66) (66) (66)

(67,68,69,70)(19) 가 (66)

(64) (72) (72)

(66) (66) (74) (72) (72)

(75,76,77,78) 가

(66) (66) (74) (66)

(74)

가 가 가

가 가 가

가 가 가

x 가 18 17

(64) (67)

) (72) (62) (75)

(77) 가

(66) (69) 가

가

가

가

가

(57)

1.

(10, 10a, 10b, 10c, 10d, 60)

(aerial image measurement equipment)

(20, 20a, 20c, 20d, 49, 66)

20, 20a, 20c, 20d, 49, 66)

(20, 20a, 20c, 20d, 49, 66)

(20, 20a, 20c, 20d, 49, 66)

(step)

(20, 20a, 20c, 20d, 49, 66)

(s

tep)

(20, 20a, 20c, 20d, 49, 66)

2.

1

가

(10, 10a, 10b, 10c, 10d, 60)

3.

1

(20, 20a, 20c, 20d, 49, 66)

20a, 20c, 20d, 49, 66)

(20,

4.

3

(20, 20a, 20c, 20d, 49, 66)

(20, 20a, 20c, 20d, 49, 66)

5.

1

(20, 20a, 49)

6.

1

가

(20c, 20d)

7.

1

(20, 20a, 49)

8.

(10, 10a, 10b, 10c, 10d, 60)

(aerial images)

(20, 20a, 20c, 20d, 49, 66)

(20, 20a, 20c, 20d, 49, 66)

(20, 20a, 20c, 20d, 49, 66)

(20, 20a, 20c, 20d, 49, 66)

(20, 20a, 20c, 20d, 49, 66) -
 (22, 24, 23, 25, 47, 43, 44, 45, 67, 68, 69, 70)
 0) (20, 20a, 20c, 20d, 49, 66) (20, 20a, 20c, 20d, 66)

9.

10.

11.

12.

13.

14.

(10, 10a, 10b, 10c, 10d, 60)

(32, 34)

- (12, 62) (14, 64)
 - (14, 64) (18) (20, 20a, 20c, 20d, 49, 66) (22, 24, 23, 25, 47, 43, 44, 45, 67, 68, 69, 70) 가
 - (20, 20a, 20c, 20d, 49, 66) (36, 36a, 36c, 36d, 48, 74)
 - (36, 36a, 36c, 36d, 48, 74) (20, 20a, 20c, 20d, 49, 66) (36, 36a, 36c, 36d, 48, 74)
 - (22, 24, 23, 25, 47, 43, 44, 45, 67, 68, 69, 70)
 - (22, 24, 23, 25, 47, 43, 44, 45, 67, 68, 69, 70) (20, 20a, 20c, 20d, 49, 66)
 - (20, 20a, 20c, 20d, 49, 66) (22, 24, 23, 25, 47, 43, 44, 45, 67, 68, 69, 70) 가

15.

14 (14, 64)

16.

14 (10, 10a, 10b, 10c, 10d, 60) (26)
 (28) (20, 20a, 20c, 20d, 49, 66)
 (36, 36a, 36c, 36d, 48, 74) (26)

17.

14 (22, 24, 23, 25, 47, 43, 44, 45, 67, 68, 69, 70) 가 (20, 20a, 20c, 20d, 66)
 가 (36, 36a, 36c, 36d, 74)

18.

17 (20, 20a, 20c, 20d, 66) (22, 24, 23, 25, 47, 43, 44, 45, 67, 68, 69, 70)
 (36, 36a, 36c, 36d, 74)
 x y

19.

14 가 (20, 20a, 20c, 20d, 66)
 (36, 36a, 36c, 36d, 48, 74) (36, 36a, 36c, 36d, 48, 74) (20, 20a, 20c, 20d, 66)
 (36, 36a, 36c, 36d, 48, 74) (20, 20a, 20c, 20d, 66)

20.

| | | | | |
|------------------------------|-----------------------------|-----------------------------|-------------------|--------------------------|
| 14 20a, 20c, 20d, 49, 66) | , | (36, 36a, 36c, 36d, 48, 74) | - | (20, |
| 21. | | | | |
| 20 | , | (36, 36a, 36c, 36d, 48, 74) | (47, 43, 44, 45)가 | - |
| | (20, 20a, 20c, 20d, 49, 66) | | | |
| 22. | | | | |
| 20 | , | (36, 36a, 36c, 36d, 48, 74) | - | |
| | (20, 20a, 20c, 20d, 49, 66) | | | |
| 23. | | | | |
| 20 | , | (36, 36c) | - | (20, 20c, 66) |
| | (41) | | | |
| 24. | | | | |
| 20 | , | (36d) | - | (20d) |
| | (41d) | | | |
| 25. | | | | |
| 14 | , | | | |
| 26. | | | | |
| 25 | , | | | |
| 27. | | | | |
| 25 | , | | | |
| 28. | | | | |
| 27 | , | | | |
| 29. | | | | |
| 14 | , | | (36, 36a, 48) | |
| 30. | | | | |
| 14 | , | | (36c, 36d) | |
| 31. | | | | |
| 14 | , | | (36, 36a, 48) | |
| 32. | | | | |
| - | | (10, 10a, 10b, 10c, 60) | , | |
| (72)가 | (12, 62) | (36, 36a, 36c, 36d, 48, 74) | | |
| | , | (12, 62) | (72) | (18) |
| 48, 74) | | | | (36, 36a, 36c, 36d, |
| 33. | | | | |
| 32 | , | (36, 36a, 36c, 36d, 48, 74) | | |
| 34. | | | | |
| 32 | , | | 가 | |
| - | 가 | | , | (10, 10a, 10b, 10c, 10d, |
| 60) | | (30, 72) | , | |
| - | 가 | (30, 72) | , | |
| - | | (36, 36a, 36c, 36d, 48, 74) | 가 | (30, 72) |
| - | 가 | (30, 72) | | |
| - | 가 | | | |

35.

(72)가 , (72) (75, 76, 77, 78) (72) -
 (67, 68, 69, 70) , -
 (36, 36a, 36c, 36d, 48, 74) (12, 62) ()
 72) (18)

36.

(10, 10a, 10b, 10c, 10d, 60)
 - (12, 62) (14, 64) ,
 - (14, 64) (18) - (20, 20a, 20c, 20d, 49, 66) (22, 24, 23, 25, 47, 43, 44, 45, 67, 68, 69, 70) 가 ,
 - (14, 64) (30, 72) ,
 - (20, 20a, 20c, 20d, 49, 66) (74)
 (30, 72) (30, 72) - (20, 20a, 20c, 20d, 49, 66) (75, 76, 77, 78) 가 ,
 (74) - (22, 24, 23, 25, 47, 43, 44, 45, 67, 68, 69, 70)
 - (75, 76, 77, 78) ,
 (30, 72)가 (12, 62) (75, 76, 77, 78) ,
 7, 78) - (22, 24, 23, 25, 47, 43, 44, 45, 67, 68, 69, 70) 가 ,

37.

36

38.

36

가가 (30, 72) (30, 72)

39.

38

가

- 가 (10, 10a, 10b, 10c, 10d, 60)
 (30, 72) ,
 - 가 (30, 72)
 - (36, 36a, 36c, 36d, 48, 74) 가 (30, 72)
 - 가 (30, 72)
 가

40.

36

(10, 10a, 10b, 10c, 10d, 60) - (26)
 (28) (20, 20a, 20c, 20d, 49, 66)
 (36, 36a, 36c, 36d, 48, 74) (26)

41.

36

- (22, 24, 23, 25, 47, 43, 44, 45, 67, 68, 69, 70) 가 - (20, 20a, 20c, 20d, 66)
 - 가 (36, 36a, 36c, 36d, 74)

42.

41

- (36, 36a, 36c, 36d, 74)
 (20, 20a, 20c, 20d, 66) (22, 24, 23, 25, 47, 43, 44, 45, 67, 68, 69, 70)
 x y

43.

36 , , - (20, 20a, 20c, 20
d, 66) (36, 36a, 36c, 36d, 48, 74)
(36, 36a, 36c, 36d, 48, 74) - (20, 20a, 2

0c, 20d, 66)
44.
36 (36, 36a, 36c, 36d, 48, 74) -
(20, 20a, 20c, 20d, 66)

45.
36

46.
(10, 10a, 10b, 10c, 10d, 60)
(36, 36a, 36c, 36d, 48, 74)
(36, 36a, 36c, 36d,
48, 74)
가
- 가 (10, 10a, 10b, 10c, 1
0d, 60)
- 가 (30, 72)
- (36, 36a, 36c, 36d, 48, 74) 가 (30, 72)
- 가 (30, 72)
가

47.
(10, 10a, 10b, 10c, 10d, 60)
- (12, 62) (14, 64)
- (14, 64) (18) - (20, 20a, 20c, 20d, 49
, 66) (20, 20a, 20c, 20d, 49, 66) (22, 24, 2
3, 25, 47, 43, 44, 45, 67, 68, 69, 70) 가
- (14, 64) (30, 72)
- - (20, 20a, 20c, 20d, 49, 66) (74)
(30, 72) (30, 72) - (20, 20a, 20c, 2
0d, 49, 66) (75, 76, 77, 78) 가
(74) - (22, 24, 23, 25, 47, 43, 44, 45, 67, 68, 69, 70)
(75, 76, 77, 78)
- (75, 76, 77, 78) - (22, 24, 2
3, 25, 47, 43, 44, 45, 67, 68, 69, 70)
가
- 가 (10, 10a, 10b, 10c, 10d, 60)
- 가 (30, 72)
- (36, 36a, 36c, 36d, 48, 74) 가 (30, 72)
- 가 (30, 72)
가

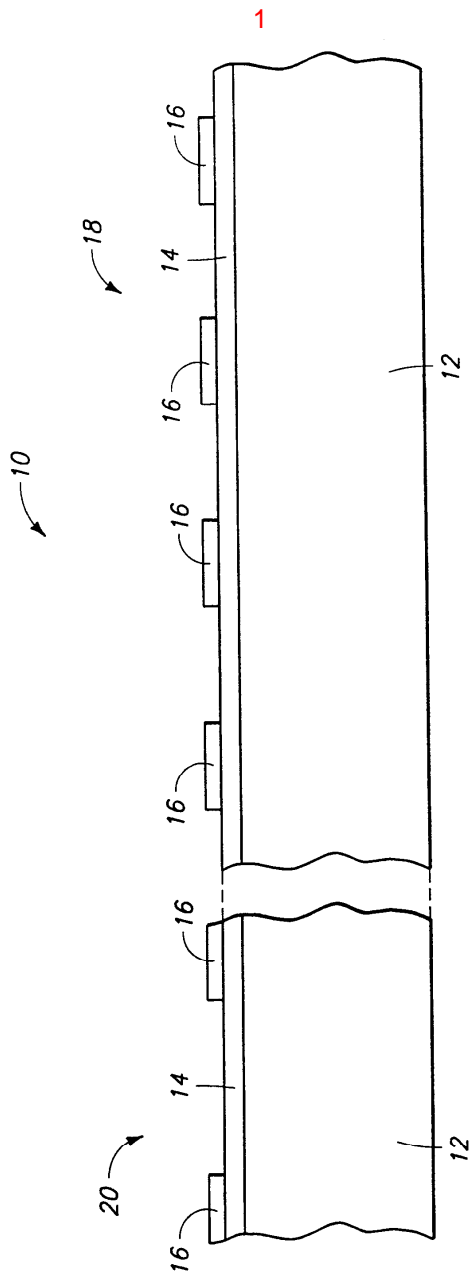

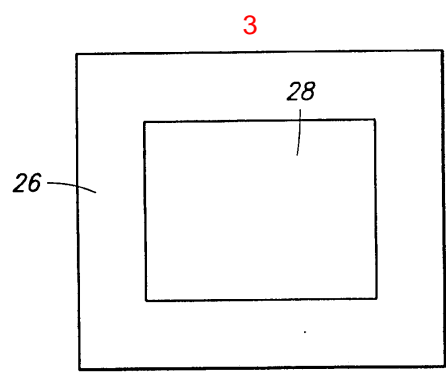
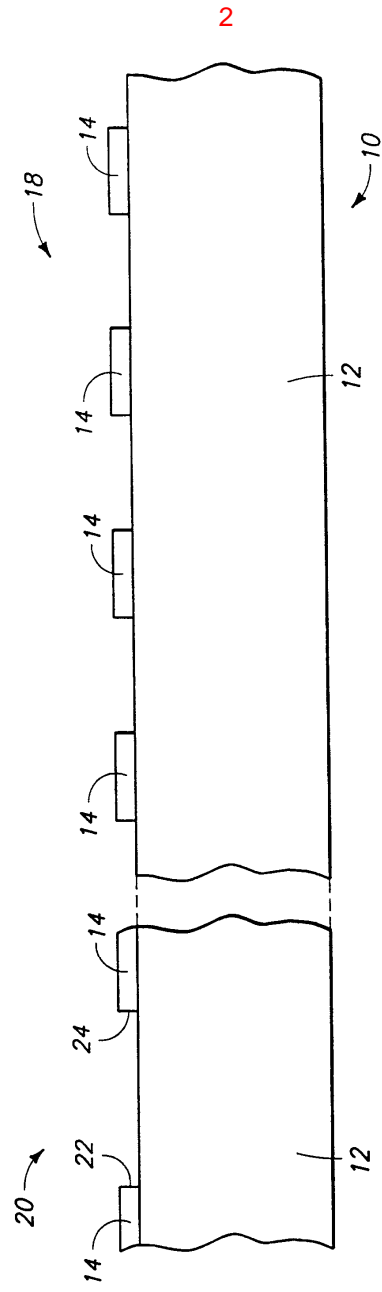

4

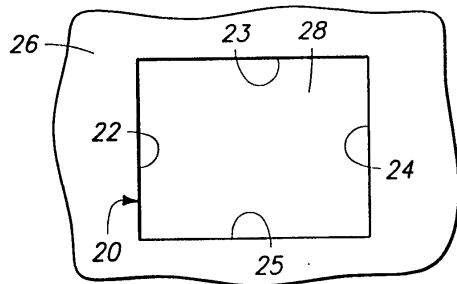

5

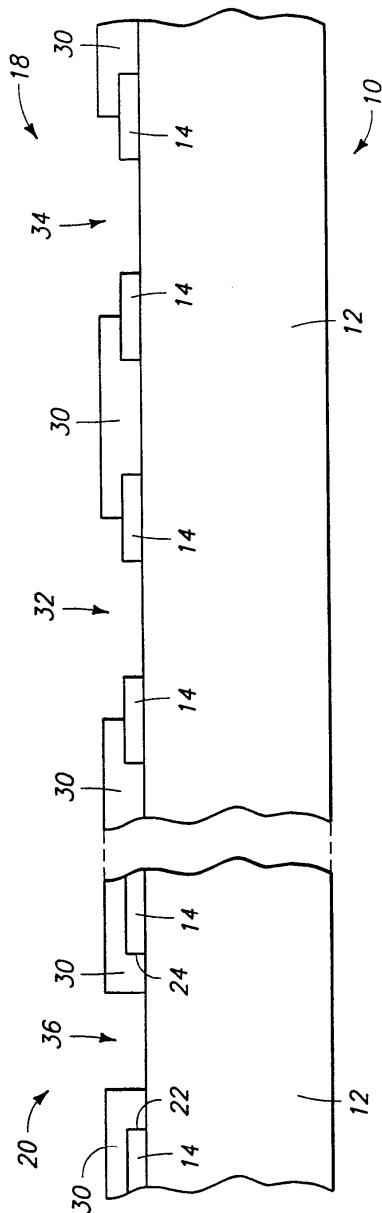

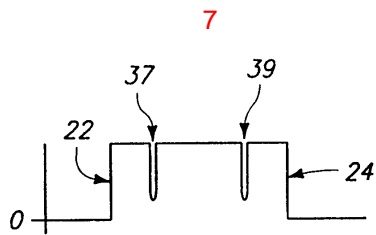
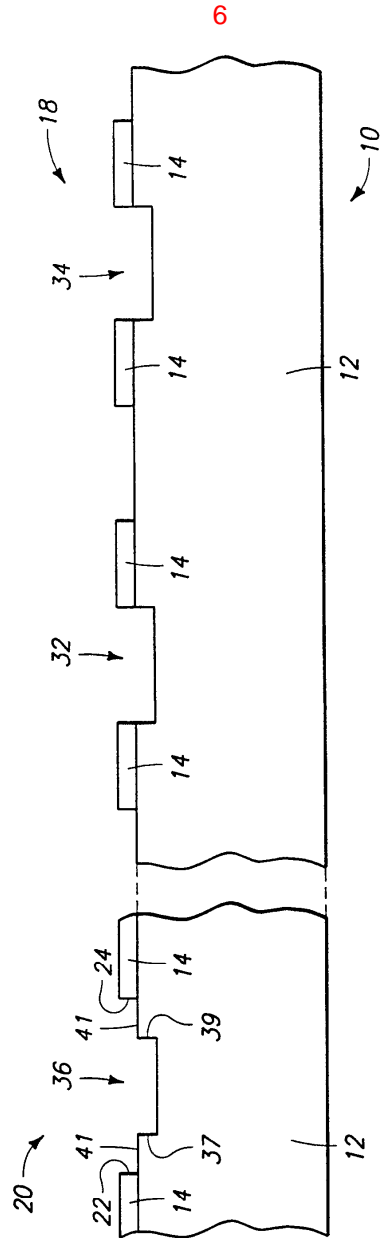

8

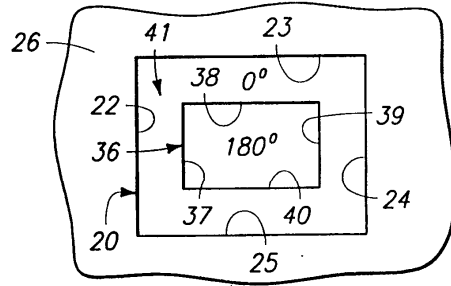

9

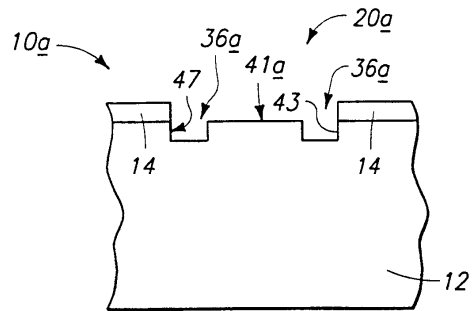

10

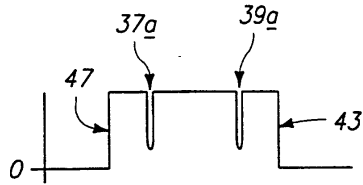

11

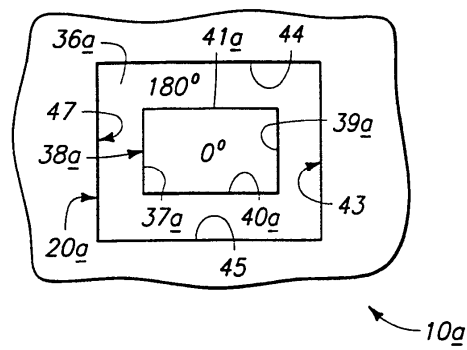

12

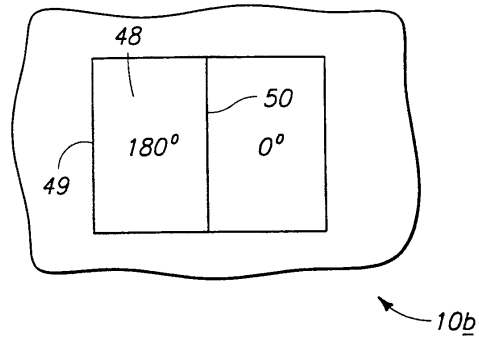

13

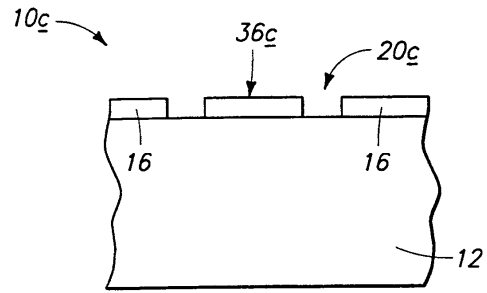

14

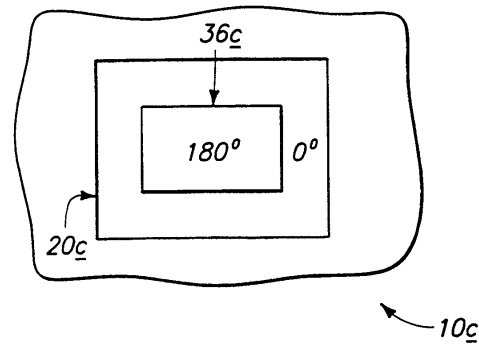

15

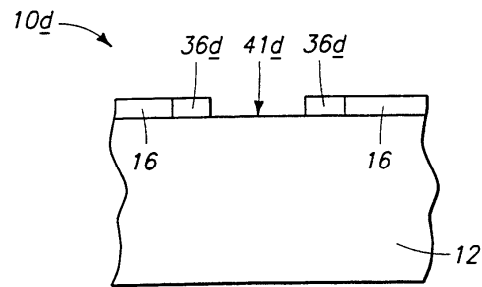

16

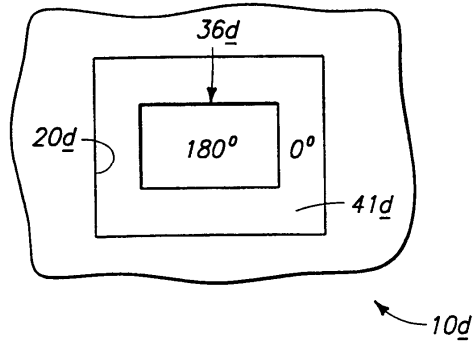

17

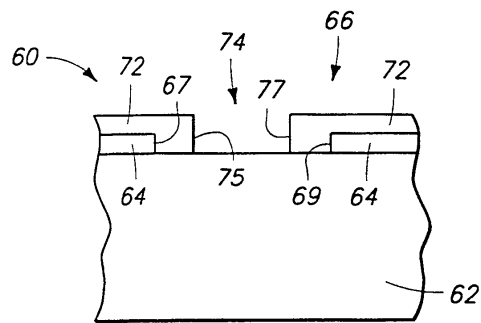

18

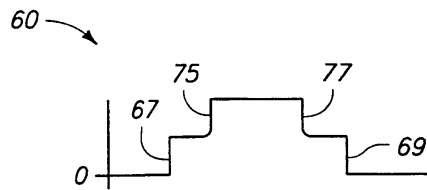

19

