

S. M. King,

Excavator.

No. 108,269.

Patented Oct. 11, 1870.

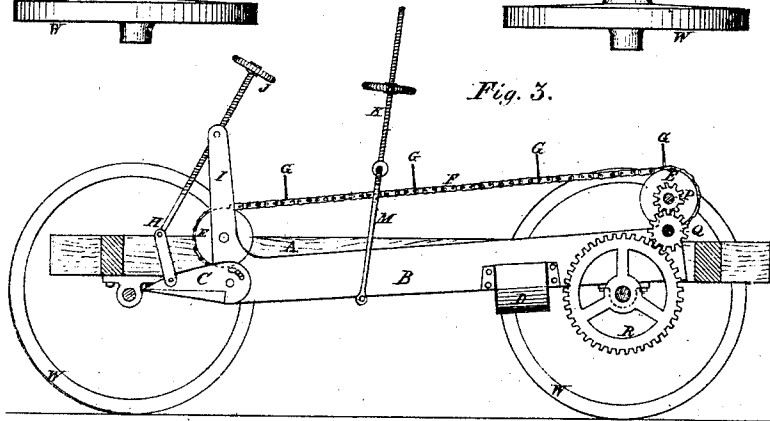
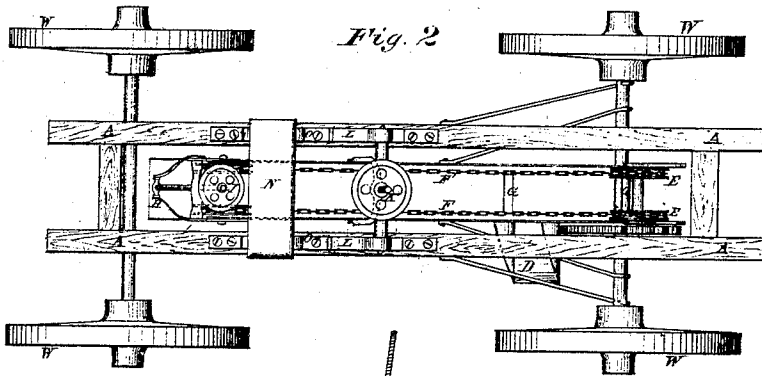
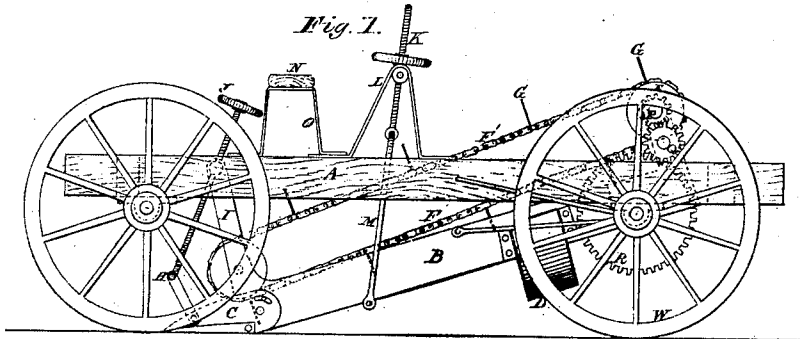

Witnesses:
J. C. Brecht.
Wm. Burke.

Inventor:
Samuel M. King
per J. Stauffer att.

United States Patent Office.

SAMUEL M. KING, OF LANCASTER, PENNSYLVANIA.

Letters Patent No. 108,269, dated October 11, 1870.

IMPROVEMENT IN MACHINES FOR CLEANING AND DITCHING RICE-FIELDS.

The Schedule referred to in these Letters Patent and making part of the same.

I, SAMUEL M. KING, of Lancaster, in the county of Lancaster and State of Pennsylvania, have invented certain Improvements in Machines for Cleaning or Ditching the Trenches in Fields for the Cultivation of Rice, of which the following is a specification.

The object of my invention is to supply a want greatly felt in the rice-fields; that is, to provide a more speedy and easier way of cleaning out or digging the ditches required, by machinery, instead of by hand, as heretofore performed, which is accomplished by means of a scoop, connected with a trough, and provided with a series of scrapers to carry the debris upward and backward, the same being on the side, by simply driving over the line of the ditch or trench.

The accompanying drawing clearly shows my improved implement.

Figure 1 is a side elevation.

Figure 2, a plan view.

Figure 3, a longitudinal section.

To enable others skilled in the art to make and use my invention, a brief reference to the drawing and letters marked thereon will suffice.

In a suitable frame having four wheels, the hind ones of which are rigidly attached to the axle, is placed the machinery, which I will describe as follows:

A A represent two planks or timbers, which are set on edge, parallel to each other, and extend from the axle of the front wheels to that of the hind wheels.

Between these side pieces A the box-trough B, with its jointed or hinged scoop C, is placed.

This trough B is hinged on the hind axle of the wheels W, as its fulcrum.

The axle also supports and operates a cog-wheel, R, which drives a pinion, Q, geared to another pinion, P, on the pulley-shaft, which, by the forward motion of the wheel, drives the chain-pulleys E.

These chains F and pulleys E are of the ordinary kind, and the chains F are provided with scrapers G, at certain intervals, of such size as to adapt them to the width of the trough B. They are also so arranged on the pulleys as to bring them successively into the back portion of the trough B, and follow close to the bottom of the sides as they are carried by the endless chains, or an endless apron of blocks, or their equivalent, on spiked, cogged, or angled pulleys.

This trough has an opening in the bottom, for an inclined chute or discharge-spout, D, on one or both sides of the trough, near the hind wheels, of any desired size.

The trough is adjusted to any inclination, by means of the rods M, attached to the bottom toward the for-

ward portion, and united centrally with a head for a screw-rod, K, which is supported in a vibrating cross-piece on supports D, affixed on the upper edge of the side pieces A.

This screw has a wheel-nut, L, by which the box or trough B is raised and lowered.

A similar adjusting turning screw-rod and hinged clevis, H, is connected with the forward portion of the scoop C, with a female screw cut in a pivoted cross-head on the extended bearings I, of the front chain-pulleys E, by which the scoop or shovel can be raised or adjusted.

N O show a seat and its supports for the driver.

The operation is readily understood.

For cleaning out the mud and debris of a ditch, the team is brought to straddle the same, so as to have the ditch centrally between the wheels. The trough and scoop is lowered according to the nature of the work to be performed, and will cut out or clean out six inches deep, by moving the team in a line with the ditch.

The scoop will collect the mud or soil, which the scrapers will draw into the trough, and carry it up the inclined plane and backward to the offset in the bottom, where it drops onto the inclined chute or trough, and is discharged on the side, between the ditch and the wheels. These scrapers will move in proportion with the speed of the horses, and are calculated to carry all the scoop can gather, as fast as deposited thereon, in its forward motion.

Thus, this vehicular ditching-machine can be driven back and forth, or make any turns in following the trenches of moderate curves, until the ditch is cleaned out or dug out to the desired depth.

I am aware that endless chains and scrapers are not new, and that digging-machines with scoops or shovels have been used; but I am not aware that any machine has ever been used that is mounted on wheels, and digs or cleans a trench by a continuous forward motion, as it is drawn over the ground by horses, so as to adapt it for the rice-fields, to open or keep open the trenches used in the cultivation of rice.

What I claim as new, and desire to secure by Letters Patent of the United States, is—

The adjustable scoop C, in combination with the trough B, screw-rod H, and wheel J, as described.

SAML. M. KING.

Witnesses:

WM. B. WILEY,
JACOB STAUFFER.