

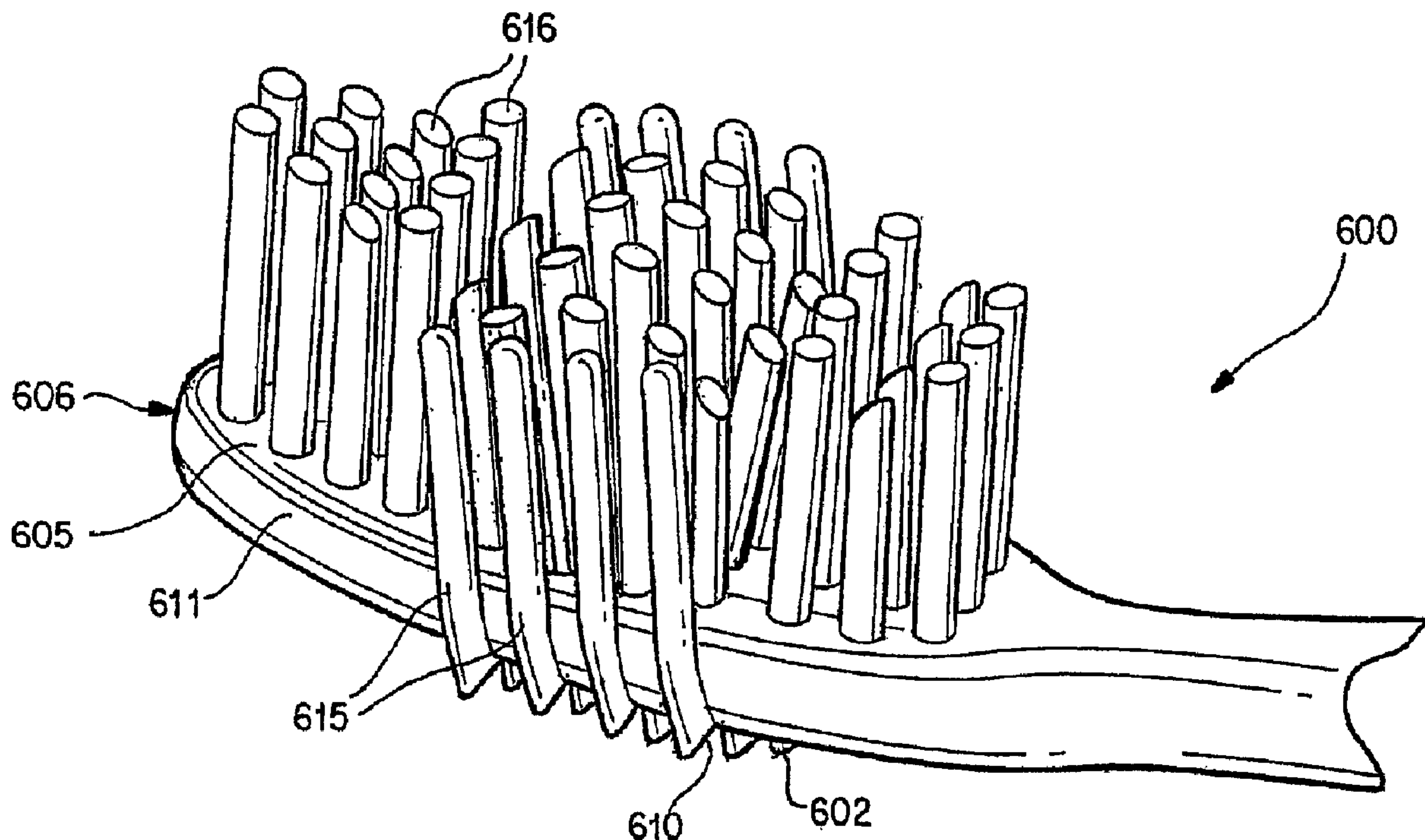

(22) Date de dépôt/Filing Date: 2005/12/21  
 (41) Mise à la disp. pub./Open to Public Insp.: 2006/07/06  
 (62) Demande originale/Original Application: 2 592 183  
 (30) Priorité/Priority: 2004/12/23 (US11/019,685)

(51) Cl.Int./Int.Cl. *A46B 15/00* (2006.01),  
*A61C 17/00* (2006.01)  
 (71) Demandeur/Applicant:  
COLGATE-PALMOLIVE COMPANY, US  
 (72) Inventeurs/Inventors:  
HOHLBEIN, DOUGLAS J., US;  
MINTEL, THOMAS E., US;  
BAERTSCHI, ARMIN, CH  
 (74) Agent: SMART & BIGGAR

(54) Titre : INSTRUMENT D'HYGIENE DENTAIRE DOTE D'UN NETTOYEUR DE TISSUS  
 (54) Title: ORAL CARE IMPLEMENT HAVING A TISSUE CLEANER



(57) Abrégé/Abstract:

An oral care implement with a handle includes a head (506) with a tissue cleanser (508). The tissue cleanser may be a pad composed of an elastomeric material. The pad is disposed on the head on a surface opposite the tooth cleaning elements. The tissue cleanser may include a plurality of nubs (502) extending for cleaning between the papillae of the tongue. The tissue cleanser may include a plurality of conically shaped nubs. A tissue cleanser can be used to reduce oral malodor problems and remove oral epithelial cells.



**ABSTRACT**

An oral care implement with a handle includes a head (506) with a tissue cleanser (508). The tissue cleanser may be a pad composed of an elastomeric material. The pad is disposed on the head on a surface opposite the tooth cleaning elements. The tissue cleanser may include a plurality of nubs (502) extending for cleaning between the papillae of the tongue. The tissue cleanser may include a plurality of conically shaped nubs. A tissue cleanser can be used to reduce oral malodor problems and remove oral epithelial cells.

62301-2675D1

**ORAL CARE IMPLEMENT HAVING A TISSUE CLEANSER**

This is a divisional of Canadian (National Phase) Patent Application 2,592,183 having a filing date of December 21, 2005.

62301-2675D1

**FIELD OF THE INVENTION**

[02] The present invention pertains to an oral care implement with a cleanser for cleaning soft tissue surfaces in the mouth.

**BACKGROUND OF THE INVENTION**

[03] According to the American Dental Association, a major source of bad breath in healthy people is microbial deposits on the tongue, where a bacterial coating harbors organisms and debris that contribute to bad breath. The tongue is a haven for the growth of microorganisms since the papillary nature of the tongue surface creates a unique ecological site that provides an extremely large surface area, favoring the accumulation of oral bacteria. Anaerobic flora and bacteria residing on the tongue play an important role in the development of chronic bad breath commonly called halitosis. In general, the bacteria produce volatile sulfur compounds (VSC). If there is enough buildup of the sulfur compounds, the result can be lead bad breath or oral malodor.

[04] Bladed tongue scrapers have been used in the past, but have generally been inadequate in respect to their effectiveness and/or safety. Moreover, notwithstanding the benefits to be gained by any ability to clean the tongue, some users avoid the use of such blades because of lack of comfort on the tongue surface.

[05] Hence, there is a need for an oral care implement with a tongue cleanser that provides effective removal of the tongue bacteria and other debris while maintaining comfort to the user.

62301-2675D1

## BRIEF SUMMARY OF THE INVENTION

- [06] The invention pertains to an oral care implement with a tissue cleanser that provides improved cleaning and effective removal of bacteria and microdebris disposed on the oral tissue surfaces.
- [07] In one aspect of the invention, the tissue cleanser includes a plurality of nubs for cleaning soft tissue surfaces in the mouth and particularly for cleaning between the papillae of the tongue. In a further preferred aspect of the invention, the tissue cleanser includes a plurality of conically shaped nubs.
- [08] In another aspect of the invention, the tissue cleanser is constructed from an elastomeric material. In one preferred embodiment, the tissue cleanser is formed as an elastomeric pad mounted on the head of the oral care implement for improved cleaning, ease of manufacture, and user comfort.
- [09] In another aspect of the invention, the tissue cleanser includes at least one projection that protrudes from a base of material extending along the head of the implement. In one embodiment, a plurality of projections extend along the head in a spaced apart relationship along a pad formed as an elongate strip that is fixed to the head. In one construction, the base overlies a generally rigid head structure. Alternatively, the base is integrally formed as part of the head thereby forming a flexible head.
- [10] In another aspect of the invention, the soft tissue cleanser includes a combination of at least one elongate ridge and a plurality of nubs or other discrete projections having a non-elongate structure. As a result, the tongue and other soft tissue of the mouth are cleaned with the benefit of both kinds of cleanser projections for an enhanced cleaning effect.

62301-2675D1

- [11] In another aspect of the invention, the soft tissue cleanser includes a combination of hard and soft projections to clean the tongue and other soft tissue in the mouth. In one construction, the cleanser includes a plurality of soft nubs and at least one elongate ridge of hard material. In this way, the combined benefits of a soft and hard cleanser can be gained in one implement.
- [12] In another aspect of the invention, the soft tissue cleanser includes at least one projection with a scraping edge to be moved over the tongue or other tissue. The edge is formed by sloped surfaces having different inclinations. In one construction, a steeper slope faces generally toward the handle to provide a more aggressive scraping action as the head is dragged out of the mouth. The shallower surface makes the projection less prone to pushing tongue biofilm farther back in the throat.
- [13] In another aspect of the invention, the oral care implement includes a seat to facilitate and ease molding of the tissue cleanser to the head. In one preferred construction, the head has one or more protuberances for anchoring the head during molding of the tissue cleanser. The head may also include a basin to further define the outline of the molded tissue cleanser.
- [14] In another aspect of the invention, an oral care implement includes a tissue cleanser having means for reducing oral volatile sulfur compounds by 35% from a baseline measured two hours after use.
- [15] In another aspect of the invention, an oral care implement is provided with tooth cleaning elements and a tissue cleanser for a thorough cleaning of the teeth, gums, tongue and oral surfaces of the cheeks and lips. In a preferred construction, the tooth cleaning elements and tissue cleanser are supported on opposite sides of a supporting head.

62301-2675D1

**[16]** In another aspect of the invention, an oral care implement which includes tooth cleaning elements and a tissue cleanser forms at least one of the tooth cleaning elements as a unitary member with the tissue cleanser.

**[16a]** In another aspect of the invention, an oral care implement comprising: a head  
5 having a first surface, an opposite second surface, and sidewalls extending between the first and second surfaces; a cleanser for cleansing soft tissue in the mouth, the cleanser being formed of a resilient material and including a base having a main portion fixed to the first surface and side portions fixed to the sidewalls, and at least one projection protruding outward from the base for removal of microbial and other debris from the soft tissue; and cleaning elements projecting from  
10 the second surface of the head and from the side portions of the base for acting on a user's teeth and gums.

**[16b]** In another aspect of the invention, an oral care implement comprising: a head having a first surface, an opposite second surface, and sidewalls extending between the first and second surfaces; a cleanser for cleansing soft tissue in the mouth, the cleanser being formed of a  
15 resilient material and including a base having a main portion fixed to the first surface and side portions fixed to the sidewalls, and at least one projection protruding outward from the base for removal of microbial and other debris from the soft tissue; cleaning elements projecting from the second surface of the head and from the side portions of the base for acting on a user's teeth and gums; wherein the cleaning elements projecting from the side portions are formed as one piece  
20 with the base; wherein the base, the at least one projection, and the cleaning elements projecting from the side portions are formed of an elastomer; and wherein a plurality of said bases each in the form of an elongate strip are fixed to the head, each including a plurality of said projections.

**[16c]** In another aspect of the invention, an oral care implement comprising: a head having a first surface, an opposite second surface, and sidewalls extending between the first and  
25 second surfaces; a cleanser for cleansing soft tissue in the mouth, the cleanser comprising: a base having a main portion fixed to the first surface; side portions fixed to the sidewalls; a plurality of projections protruding outward from the base for removal of microbial and other debris from the soft tissue; and a plurality of cleaning elements projecting from the side portions of the base for

62301-2675D1

acting on a user's teeth and gums; wherein the plurality of teeth cleaning elements projecting from the side portions are formed as one piece with the base; wherein the base, the plurality of projections, and the plurality of cleaning elements projecting from the side portions are formed of an elastomer; and wherein the main portion is formed of a plurality of elongate strips and wherein  
5 each of the side portions is an extension of one of the elongate strips, each of the plurality of elongate strips including a plurality of said projections.

### **BRIEF DESCRIPTION OF THE DRAWINGS**

[17] A more complete understanding of the present invention and the advantages thereof may be acquired by referring to the following description in consideration of the  
10 accompanying drawings, in which like reference numbers indicate like features, and wherein:

[18] Figure 1 is an exploded assembly perspective view of an oral care implement according to one or more aspects of an illustrative embodiment;

[19] Figure 2 is an enlarged perspective view of a head of an oral care implement of FIG. 1;

15 [20] Figure 3 is a plan view of the oral care implement of FIG. 1 illustrating a tongue cleaning feature;

[21] Figure 4 is a partial section view of a head of the oral care implement of FIG. 1 taken along line 4-4 of FIG. 3;

20 [22] Figure 5 is a plan view of the oral care implement of FIG. 1 illustrating at least one tooth cleaning configuration;

[23] Figure 6 is a perspective of the view of the oral care implement illustrating example tooth cleaning elements; and

[24] Figure 7 is a section view of an alternative construction of the head of an oral care implement.

25 [25] Figure 8 is a perspective view of an alternative embodiment of the invention.



62301-2675D1

- [26] Figure 9 is a partial cross-sectional view taken along line IX-IX in Figure 8.
- [27] Figure 10 is a partial cross-sectional view of an alternative embodiment of the invention taken along line IX-IX in Figure 8.
- [28] Figure 11 is a partial cross-sectional view of another alternative embodiment taken along line IX-IX in Figure 8.
- [29] Figure 12 is a partial cross-sectional view of another alternative embodiment taken along line IX-IX in Figure 8.
- [30] Figure 13 is a partial perspective view of an alternative oral care implement in accordance with the present invention.
- [31] Figure 14 is a partial cross-sectional view taken along line XIV-XIV in Figure 13.
- [32] Figure 15 is a partial perspective view of an alternative oral care implement in accordance with the present invention.

#### DETAILED DESCRIPTION OF THE INVENTION

- [33] In the following description, the invention is discussed in terms of a toothbrush. For example, toothbrush 100 is shown as one embodiment in Figure 1, and toothbrush 500 as an alternative embodiment in Figure 8. Nevertheless, the invention could be used in other oral care implements including simply a tissue cleansing implement. Further, it is to be understood that other embodiments may be utilized and structural and functional modifications may be made without departing from the scope of the present invention.
- [34] As seen in Figures 1-7, an oral care implement in the form of a toothbrush 100 includes a handle 103 and a head 105 which may be used for cleaning the teeth and soft tissue in the mouth, such as the tongue, interior surfaces of the cheeks, lips or the

62301-2675D1

gums. Handle 103 is provided for the user to readily grip and manipulate the toothbrush, and may be formed of many different shapes and constructions. While the head is normally widened relative to the neck of the handle, it could in some constructions simply be a continuous extension or narrowing of the handle. In the preferred construction, head 105 has a first face 106 that supports tooth cleaning elements 107 (FIGS. 5 and 6) and a second face 108 that supports a tissue cleanser 300 (FIGS. 2 and 3). The first and second faces 106, 108 are preferably on opposite sides of head 105. Nevertheless, tissue cleanser 300 may be mounted elsewhere, such as the proximal end 104 of handle 103. The tissue cleanser 300 or portions of it may also be located on the peripheral sidewall surface 101 of head 105 or extend farther towards the proximate end 104 of handle 103 than illustrated.

[35] The elastomeric material of tissue cleanser 300 may be any biocompatible resilient material suitable for uses in an oral hygiene apparatus. To provide optimum comfort as well as cleaning benefits, the elastomeric material preferably has a hardness property in the range of A8 to A35 Shore hardness. As an example, one preferred elastomeric material is styrene-ethylene/butylene-styrene block copolymer (SEBS) manufactured by GLS Corporation. Nevertheless, SEBS material from other manufacturers or other materials within and outside the noted hardness range could be used.

[36] Tissue cleanser 300 is preferably configured with a multiplicity of tissue engaging elements 303 (FIGS. 1-4), which in the preferred construction are formed as nubs. Alternative nub constructions 502, as discussed below, are also illustrated in alternative constructions in Figures 8-12. As used herein a "nub" is generally meant to include a column-like protrusion (without limitation to the cross-sectional shape of the protrusion) which is upstanding from a base surface. In a general sense, the nub,

62301-2675D1

in the preferred construction, has a height that is greater than the width at the base of the nub (as measured in the longest direction). Nevertheless, nubs could include projections wherein the widths and heights are roughly the same or wherein the heights are somewhat smaller than the base widths. Moreover, in some circumstances (e.g., where the nub tapers to a tip or includes a base portion that narrows to a smaller projection), the base width can be substantially larger than the height.

[37] Such tissue engaging elements 303 are designed to significantly reduce a major source of bad breath in people and improve hygiene. Nubs 303 enable removal of microflora and other debris from the tongue and other soft tissue surfaces within the mouth. The tongue, in particular, is prone to develop bacterial coatings that are known to harbor organisms and debris that can contribute to bad breath. This microflora can be found in the recesses between the papillae on most of the tongue's upper surface as well as along other soft tissue surfaces in the mouth. When engaged or otherwise pulled against a tongue surface, for example, nubs 303 of elastomeric tissue cleanser 300 provide for gentle engagement with the soft tissue while reaching downward into the recesses of adjacent papillae of the tongue. The elastomeric construction of tissue cleanser 300 also enables the base surface 301 to follow the natural contours of the oral tissue surfaces, such as the tongue, cheeks, lips, and gums of a user. Moreover, the soft nubs 303 are able to flex as needed to traverse and clean the soft tissue surfaces in the mouth along which it is moved.

[38] As seen in Figure 2 and 4, in one preferred arrangement of tissue cleanser 300, nubs 303 are preferably conically shaped. As used herein, "conically shaped" or "conical" is meant to include true cones, frusto-conically shaped elements, and other shapes that taper to a narrow end and thereby resemble a cone irrespective of whether they are uniform, continuous in their taper, or have rounded cross-sections. With reference to

62301-2675D1

Figure 4, the base portion 305 of each conically shaped tissue engaging element 303 is larger than the corresponding tip portion 307. In this conically shaped configuration, the base portion 305 has a wider cross-sectional area to provide effective shear strength to withstand the lateral movement of the tissue cleanser 300 along the surface of the tongue or other soft tissue surface. The smaller width or diameter of the tip portion 307 in conjunction with the length of the conically shaped nub 303 enable the nubs to sweep into the recesses of the tongue and other surfaces to clean the microbial deposits and other debris from the soft tissue surfaces. In the preferred construction, nubs 303 are able to flex and bend from their respective vertical axes as lateral pressure is applied during use. This flexing enhances the comfort and cleaning of the soft tissue surfaces. In a preferred construction, the thickness or width of the base of the nub is 0.64 mm, and preferably within the range from about 0.51 mm to about 2.00 mm. Tip 307 of the nubs is 0.127 mm and preferably within a that range from about 0.10 mm to about 0.75 mm for optimal penetration between the recesses of papillae of a user's tongue. The length or height of nubs 303, as measured from base surface 301 to tip 307, is preferably 0.91 mm and preferably within range from about 0.5 mm to about 2.5 mm, and most preferably range between 0.75 mm to 1.5 mm. Nevertheless, nubs of other sizes and shapes outside the given ranges can be used.

[39] Alternatively, the tissue cleaning elements 303 may have other shapes. As one example, the tissue cleanser may have a grated form such as described in co-pending U.S. Patent Application Serial No. 10/601,106.

[40] In a preferred construction, nubs 303 are disposed on the base surface 301 of tissue cleanser 300 in a high density pattern. Each nub 303 is preferably spaced apart from adjacent nubs 303 between a range of about 0.5 mm to about 3 mm; more preferably

62301-2675D1

the spacing ranges between 0.7 mm to 2.5 mm, and most preferably between 1 mm to 2 mm. Nevertheless, other spacing ranges are possible. The surface density of the nubs 303 on base surface 301 ranges preferably from about 100 to about 600 nubs per square inch. In a more preferred construction of the tissue cleanser, the surface density may range from 200 to 500 nubs per square inch, and most preferably between 300 to 450 nubs per square inch. In one preferred example, tissue cleanser 300 includes about 400 nubs per square inch of surface area. The surface density features in conjunction with the height of the nubs 303 enables the tissue cleanser to provide enhanced cleaning of the soft tissue surfaces with improved comfort. Nonetheless, other surface densities are possible.

[41] As seen in Figure 3, nubs 303 are preferably disposed in longitudinal rows in a direction generally parallel to the longitudinal axis a-a. Further, nubs 303 are disposed in transverse rows R1, R2 on an axis parallel to base surface 301 and generally perpendicular to the longitudinal axis a-a. In one preferred construction, adjacent nubs 303 are provided on the base surface 301 in a staggered arrangement. For example, adjacent transverse rows of nubs R1 and R2 have nubs 303 that are not directly behind each other. A first nub is said herein to be "directly behind" second nub when it is located within the lateral bounds of the second nub extending in a longitudinal direction. This configuration enables improved cleaning of the soft tissue surfaces by facilitating the removal of microflora and other debris, and especially from the recesses of adjacent papillae of the tongue. Nonetheless, the nubs could be arranged randomly or in a myriad of different patterns.

[42] Tongue cleanser 300 is preferably formed by being molded to head 105, although other manufacturing processes could be used. With reference to Figures 1 and 4, tissue cleanser 300 is preferably molded within a basin or a receiving cavity 111 in

62301-2675D1.

face 108 of head 105. The receiving cavity 111 has a lower base surface 113 and a peripheral sidewall 115 extending away from the lower base surface 113. In one mounting arrangement, nubs 303 of the tissue cleanser 300 are exposed for use with the base surface of the tissue cleanser 300 being flush or recessed relative to the surface 114 of the head. Nevertheless, other orientations are possible. Also, base surface 301 of the tissue cleanser could be embedded in head 105 or covered by another layer with nubs 303 projecting through appropriate openings.

[43] As can be seen in Figures 1 and 4, face 108 also preferably includes one or more peg members 117a-c disposed within basin 111. Peg members 117 form anchor points against the opposing mold to prevent the head from moving under the pressure of the injection molding. As a result, tissue cleanser 300 preferably includes one or more complementary apertures 311a-c which exposes the tops of peg members 117a-c. Although, the pegs are illustrated in alignment along the centerline of the head (e.g. longitudinal axis a-a), the pegs could have many different positions. Further, the pegs and basin are preferably both included with head 105, but either could be used without the other.

[44] Alternatively, basin 111 and peg members 117a-c may be provided to position and hold a previously molded tissue cleanser, although these constructions are not necessary to use such a previously molded tissue cleanser.

[45] Peg members 117a-c may take on a variety of shapes and lengths. With continued reference to the Figures 1 and 4, head 105 includes peg members 117a-c extending away from the lower base surface 113 of basin 111 to the height of the peripheral sidewall 115. The peg members 117a-c are shaped in the form of a cylinder, but other shapes and lengths of the peg members 117a-c are possible. While the molding

62301-2675D1

process would preferably bond the tissue cleanser to the head, the tissue cleanser could be performed and attached by adhesive or other known means.

[46] As shown in Figures 1-4, tissue cleanser 300 is preferably formed as a pad composed of a soft and pliable elastomeric material for comfortable cleaning and effective removal of bacteria and debris disposed on the surface of the tongue, other soft tissue in the mouth and even along the lips. The tissue cleanser 300 also provides effective massaging, stimulation and removal of bacteria, debris and epithelial cells from the surfaces of the tongue, cheeks, gums or lips.

[47] In the preferred construction (FIGS. 1-6), tissue cleansers 300 may rub against the inside surfaces of the cheeks or lips, and on the sides of the tongue while the user brushes his or her teeth, and thus provide a desired massaging, stimulation and cleaning of various soft tissue surfaces within the mouth. For example, during brushing of the facial tooth surfaces, tissue cleanser 300 is disposed on the outer face 108 of head 105 to naturally rub against the oral surfaces of the cheek. As a result, enhanced cleaning is attained without additional cleaning steps. Further, some users may sense a stimulating tingle on the cheek surfaces that leads to a positive user reaction, and even enjoyment of the comfortable feel of the tissue cleanser along the soft tissues surfaces in the mouth. Tissue cleanser 300 may also be additionally rubbed on the cheeks, tongue, etc. as desired for further cleaning aside from the contact that may occur while brushing the teeth.

[48] Referring to Figures 5 and 6, the tooth cleaning elements 107 of head 105 may include a variety of tooth cleaning elements which can be used for wiping, cleaning and massaging the user's teeth and gums. Any suitable form of tooth cleaning elements may be used. The term "tooth cleaning elements" is used in a generic sense which refers to filament bristles or elastomeric fingers or walls that have any desirable

62301-2675D1

shape. In the illustrated example of Figure 5, tooth cleaning elements 107 include distal tooth cleaning elements 203a-b disposed at a distal tip 121 of head 105, peripheral tooth cleaning elements 205a-l, longitudinal tooth cleaning elements 207a-c disposed along longitudinal axis a-a, arcuate tooth cleaning elements 209a-d and 211a-b, and proximal cleaning elements 213a,b. Tooth cleaning elements 205, 207, 211 and 213 are preferably provided as tufts of bristles whereas tooth cleaning elements 209 are preferably formed as elastomeric walls. Nevertheless, other forms and types of tooth cleaning elements may be used.

[49] Figure 7 illustrates a sectional view of an alternative arrangement of a head 400 of a toothbrush. Head 400 is similar in construction to head 105, except that tooth cleaning elements 209a-d are integrally formed with tissue cleanser 300. To accomplish the alternative construction, head 400 has appropriately sized ports or openings 401 to allow the elastomeric material to flow through the head during an injection molding process. In this construction, tooth cleaning elements 209a-d and tissue cleaner 300 are formed with the same elastomeric material. Thus, head 400 may include at least one elastomeric tooth cleaning element formed as a unitary member with tissue cleanser 300.

[50] In Figure 8, toothbrush 500 includes a plurality of nubs or other projections 502 protruding from a back side 504 of head 506 as a cleanser 508 of soft tissue in the mouth. Teeth cleaning elements 516 preferably extend from a front side 505 of head 506. The projections 502 are preferably arranged seriatim along at least one narrow base or pad in the form of a strip 510 fixed to the head 506. In the illustrated example, a plurality of generally parallel strips 510a, 510b, 510c, 510d are fixed in a generally concave shape facing away from the handle. In this one construction, the strips extend along back side 504 of head 506 and each sidewall 511, although



62301-2675D1

extensions along the sidewalls are not necessary. Any number of strips could be included. The strips could define virtually any shape or orientation on the head. For example, strips 510 could have any of the shapes disclosed for the ridges in co-pending U.S. Patent Application Serial No. 10/989,267, filed November 17, 2004, entitled "Oral Care Implement".

In the illustrated construction, strips 510

are interconnected by an axial stem 512 which extends into the handle and forms a part of the grip for the user. Further, this handle extension or even the stem is of course not necessary.

[51] In one construction, each projection 502 is generally columnar and formed with a width  $W$  of about 1.1 mm and a height  $H$  of about 1.7 mm (Fig. 9). The projections are spaced apart from each other along strip 510 a distance of about 1.0 mm. These height, width and spacing dimensions could, however, vary widely. In the illustrated embodiment, projections 502 each includes a peripheral wall 513 protruding outward from base 510, and an inclined distal end surface 514 at an angle of about 50 degrees to side surface 504 of head 506. The inclined end surface 514 defines a narrow top edge 516 along a portion of peripheral wall 513, which is advantageous for cleansing the tongue and other soft tissue. Although the end surfaces 514 are shown to be inclined in the same direction, they could be inclined in different directions.

[52] In an alternative construction (Fig. 13), head 506 is additionally formed with at least one elongate ridge 525. With this arrangement, the user is provided with a cleanser that obtains a beneficial dual cleaning effect by moving the discrete projections 502 and the ridge 525 across the tongue or other tissue. In the illustrated example, ridge 525 is a curved, elongate projection protruding generally outward along the outer edge of the remote end 527 of the head. Nevertheless, other arrangements, locations

62301-2675D1

and shapes are possible. Additional ridges could also be provided. In one preferred construction, ridge 525 is molded as one-piece with the head and formed of a relatively hard plastic such as polypropylene. The ridge, however, could be formed separately from the head and/or composed of other materials that are compatible for oral care implements.

[53] In one construction, ridge 525 is, as noted above, formed of a relatively hard material (e.g., polypropylene), while projections 502 are formed of a relatively soft material (e.g., a thermoplastic elastomer). This use of dual materials enables the benefits of both materials to be gained. The cleanser includes the firm engagement of the relatively hard scraper blade in ridge 525 and the relatively soft discrete projections that flex and turn as they dig into the tongue or other tissue.

[54] As seen in Figures 13 and 14, ridge 525 is defined by a pair of opposite sidewalls 533, 534 which meet to form a scraper edge 535. While edge 535 is relatively narrow in this construction, it could be substantially widened. In one embodiment, sidewalls 533, 534 are formed with different slopes relative to side 504 of head 506, though they could have the same slope. In one preferred construction, sidewall 533 is formed with a steeper slope than sidewall 534 to define a more aggressive scraping action as the head is pulled across the tongue by the user. The shallower slope of sidewall 534 facing generally away from the handle, makes the ridge less prone to pushing the tongue biofilm farther back in the throat as the ridge is pushed back toward the throat. In a preferred embodiment, sidewall 533 is oriented at an angle  $\alpha$  of 62 degrees relative to side 504, whereas sidewall 534 is oriented at an angle  $\beta$  of 43 degrees. Other angles could also be used for both sidewalls.

[55] In another alternative construction (Fig. 10), each projection 502a is provided with an end surface 514a having two inclined end face portions 515a, 517a and a top edge

62301-2675D1

516a. As with ridge 525, end face portion 515a, generally facing toward the handle, is preferably inclined at a steeper angle relative to side 504a than end face portion 517a, although other arrangements including end face portion having the same inclination can be used. As one example, end face portion 515a is oriented at an angle  $\alpha$  of 62 degrees relative to side 504a, and end face portion 517a is oriented at an angle  $\beta$  of 43 degrees. The steeper angle of end face portion 515a provides a more aggressive scraping action as the head is dragged out of the mouth. The shallower angle of end surface 517a makes the projection less prone to pushing the tongue biofilm farther back in the throat.

[56] Of course, other projections can be used. For example, each projection could include a non-inclined distal end or an end that tapers to a pointed tip. The projections could have a wide variety of shapes beyond the cylindrical shape shown in Figure 8. For example, the projections could have a conical shape, irregular cross sections, or be inclined to the back side 504. Moreover, the projections may also be ridge shaped to extend entirely or partially along the length of strip 510.

[57] In a preferred construction, projections 502 and strip 510 are formed as a one piece member molded or otherwise secured to head 506. The projections and strip are preferably formed as a one-piece member of a resilient thermoplastic elastomer such as styrene-ethylene/butylene-styrene block copolymer (SEBS) manufactured by GLS Corporation, but could be composed of other resilient materials, hard materials, or a combination of materials such as disclosed in U.S. patent Application Serial No. 11/011,605, filed December 15, 2004, entitled Oral Care Implement.

The projections

and strips could also be formed of the same substance as head 506 (e.g.,

62301-2675D1

polypropylene) but have a different color or the like to define it a different material from the head and thereby create at least a visually appealing brush.

[58] In one construction, strips 510 are molded to overlie a generally planar surface 504 of head 506 (Fig. 9). Nevertheless, channels 507 could be formed in side 504 to receive strips 510 therein so that side 504 and the outer surfaces 512 of strips 510 having projections 502 are generally co-planar (Fig. 11). Additionally, the strips of resilient material could be formed as an integral part of the head construction (Fig. 12). More specifically, in this alternative construction, the head includes a plurality of first members 520 joined together by a resilient second member 522 that acts as a living hinge to permit the first members to move relative to each other during use of the toothbrush. The second member also forms the base 510c of soft tissue cleanser 506 provided with projections 502. Additionally, as discussed in regard to toothbrush 400, projections 502 or 502a can be integrally formed as a one-piece member with elastomeric tooth cleaning elements extending in an opposite directions from the head.

[59] In another alternative construction (Figure 15), a toothbrush 600 includes a soft tissue cleanser 602 of any of the alternatives discussed above or others using a resilient material. In this embodiment, a portion of cleanser 602 wraps around the sidewalls 611 of head 606 and includes resilient members 615 that project from the head to provide, for example, cleaning of the teeth and gums, and massaging of the gums when the toothbrush is applied along the gum line. In one example, cleanser 602 has a construction similar to the cleanser in Figure 8 or 13. Bases 610 in the form of strips extend across the back side 604 of head 606 and over sidewalls 611. The bases are preferably formed of a soft, elastomeric material such as a thermoplastic elastomer (e.g., SEBS), but could be formed of other resilient materials. Resilient members 615

62301-2675D1

are preferably formed as one piece with the portions of the bases that overlie sidewalls 611. As shown in Figure 15, resilient members 615 project from sidewalls 611 in the same general direction as teeth cleaning elements 616. Nevertheless, they could alternatively be inclined to extend laterally outward. In addition, although resilient members 615 are shown to be inclined toward the free end of head 606, they could extend at right angles to side 605, be inclined in other directions, or have non-uniform orientations.

[60] As various changes could be made in the above methods, compositions and structures without departing from the scope of the invention, it is intended that all matter contained in this application, including all mechanisms and/or modes of interaction described above, shall be interpreted as illustrative only and not limiting in any way the scope of the appended claims.

[61] The following examples are set forth as representative of the improved operation of the present invention. These examples are not to be construed as limiting the scope of the invention.

#### EXAMPLE 1

[62] The performance nature of a toothbrush can be measured using known oral malodor assessment methods. A study was conducted to evaluate the performance of a toothbrush provided with an elastomeric tissue cleanser having conically shaped nubs, such as the preferred construction of toothbrush 100 discussed above. Human test subjects participated in the study. There was a washout or normalization period prior to testing of about 7 days in which the test subjects brushed twice a day with a fluoride dental cream (see Table 1). After the washout period, the test subjects were asked to refrain from any oral hygiene (brushing, rinsing, and flossing), eating and

62301-2675D1

drinking prior to oral testing. A baseline volatile sulfur compound (VSC) sample was taken from each of the test subjects. In the study for overnight odor control, the test subjects brushed their teeth for one minute with a fluoride dental cream (see Table 1) using toothbrush 100 provided with the above noted tissue cleanser 300. Subsequently, the subjects cleaned their tongue surface with the tissue engaging elements of the toothbrush for ten seconds. The test subjects slept overnight and returned for post treatment. VSC samples were taken at the ten-hour time point from the previous day cleaning. In the illustrative example, use of the toothbrush reduced oral VSC about 60% verses brushing the teeth alone as measured from a baseline ten hours after use. The VSC readings were obtained by gas chromatography.

#### EXAMPLE 2

[63] In another study of the above-noted toothbrush 100, there was a washout or normalization period prior to testing of about 7 days which the test subjects brushed twice a day with a fluoride dental cream (see Table 1). The test subjects were asked to refrain from any oral hygiene (brushing, rinsing, and flossing), eating and drinking before testing. After the washout period, the test subjects provided a baseline tongue bacteria sample by swabbing a side of the back of the tongue with a sterile cotton swab. The test subjects brushed their teeth with a fluoride dental cream (see Table 1) for one minute with the toothbrush having the above-noted tissue cleanser. Subsequently, the test subjects cleaned their tongue surface with a preferred construction of the tissue engaging elements 300 of the toothbrush 100 for ten seconds. Two hours after the cleaning of the tongue surface, a tongue bacteria sample was taken from a side of the back of the tongue with a cotton swab. In the illustrative example, use of the tissue engaging elements controlled more odor causing tongue bacteria than simply brushing the teeth alone. Use of the tissue cleanser 300

62301-2675D1

demonstrated a tongue bacteria log reduction of over 0.8 Log colony forming units/ml two hours after use on the tongue.

### EXAMPLE 3

- [64] In another study of the above-noted toothbrush, a MTT assay was used to examine the viability of the epithelial cells collected from the oral cavity prior to and after the use of the toothbrush with the noted tissue cleanser. The MTT Assay was based on the enzymatic reduction of the tetrazolium salt MTT [3-(4,5-dimethylthiazol-2-yl)-2,5-diphenyl-tetrazoliumbromide ++ +] in living, metabolically active cells. The reaction was carried out *in situ* in test tubes, and the reaction product, a purple-colored formazan soluble in dimethylsulfoxide, was measured colorimetrically using a multiwell plate reader. Advantageously, the MTT Assay offers a high degree of precision, ease of use, and suitability for the purpose for large scale chemosensitivity testing.
- [65] Following a 7-day washout period, the test subjects reported to a test site without prior eating, drinking, or performing oral hygiene. The test subjects provided salivary rinse samples by rinsing their oral cavity with 9 ml of sterile water for 10 seconds and then discharging the water from the rinse into a tube containing 10x sterile phosphate buffered saline(PBS) solution. The samples were refrigerated for approximately 30 minutes before the MTT Assay was run. The test subjects brushed their teeth under supervision for one minute using a fluoride dental cream (see Table 1) followed by 10 seconds of tongue cleaning with the tongue cleanser 300 of the preferred construction. Approximately 30 minutes after brushing and tongue cleaning, the test subjects provided a rinse sample in the manner described previously.

62301-2675D1

[66] The pre-rinse samples and post-rinse samples were centrifuged for 15 minutes at about 3000 RPM. The supernatant, e.g., clear liquid, was removed and the pellet was resuspended in 2.5 mL of PBS. The samples were vortexed for 5 seconds, then 2.5 ml of MTT Solution was added. The samples were subsequently incubated in a gently shaking waterbath set at 37 °C for 2 hours. Following the 2 hour incubation period, the samples were centrifuged for 15 minutes at about 3000 RPM. The supernatant was siphoned out and 3 mL of detergent (0.04 N Acid Isopropanol) was added to dissolve purple crystals. An increase or decrease in MTT conversion was spectrophotometrically quantified. From each sample, 200 µl of each was added to 96 well plates and the optical density was measured at 570 nm and compared to a negative buffer control. In the illustrative example, one minute of brushing followed by 10 seconds of use of the tissue cleanser reduced oral epithelial cells about 72% as determined by a MTT assay protocol.

#### EXAMPLE 4

[67] In another study, human test subjects provided baseline VSC samples via a Halimeter™ (i.e., a sulfide meter). A Halimeter™ uses an electrochemical, voltammetric sensor which generates a signal when it is exposed to VSC such as, sulfide and mercaptan gases and measures the concentration of hydrogen sulfide gas in parts per billion. The test subjects brushed their teeth under supervision for one minute with the preferred construction of a toothbrush having the above noted tissue cleanser. Then, the test subjects used the noted toothbrush to provide six strokes on the tongue surface. A subsequent VSC sample was taken from the test subjects two hours after the brushing stage. In this illustrative example, use of a toothbrush with the tissue cleanser reduced the measured VSC in the mouth odor over 35% from a baseline measured two hours after use.



62301-2675D1

## EXAMPLE 5

- [68] In one other study, after a washout period, human test subjects rinsed their mouths with sterile water to provide a baseline sample for viable epithelial cell analysis with the MTT assay. The subjects brushed their teeth under supervision for one minute with the preferred construction of the toothbrush having the above-noted tissue cleanser. Then, the test subjects used the tissue cleanser to provide six strokes on the tongue surface. The test subjects provided a post rinse sample for analysis. The samples were tested and analyzed in the manner as discussed with respect to Example 3. In this example, use of the toothbrush reduced oral epithelial cells by about 92% from a baseline as determined by MTT assay protocol.
- [69] In the above noted examples, the subjects brushed their teeth using a fluoride dental cream with the formulation in Table 1.

% wt.	Ingredient
48.76%	Dicalcium Phosphate Dihydrate
22.0063%	Water
22.00%	Glycerin
4.138%	SO3 Sodium Lauryl Sulfate base – 29%
1.000%	Sodium CMC – 7MF – Food Grade
0.89%	105 Dental Cream Flavor
.76%	Sodium Monofluorophosphate
.25%	Tetrasodium Pyrophosphate
.20%	Sodium Saccharin

Table 1

62301-2675D1

CLAIMS:

1. An oral care implement comprising:

a head having a first surface, an opposite second surface, and sidewalls extending between the first and second surfaces;

5 a cleanser for cleansing soft tissue in the mouth, the cleanser being formed of a resilient material and including a base having a main portion fixed to the first surface and side portions fixed to the sidewalls, and at least one projection protruding outward from the base for removal of microbial and other debris from the soft tissue; and

10 cleaning elements projecting from the second surface of the head and from the side portions of the base for acting on a user's teeth and gums.

2. An oral care implement according to claim 1 wherein the cleaning elements projecting from the side portions are formed as one piece with the base.

3. An oral care implement according to claim 2 wherein the base, the at least one projection, and the cleaning elements projecting from the side portions are formed of an  
15 elastomer.

4. An oral care implement according to claim 3 wherein a plurality of said bases each in the form of an elongate strip are fixed to the head, each including a plurality of said projections.

5. An oral care implement comprising:

20 a head having a first surface, an opposite second surface, and sidewalls extending between the first and second surfaces;

a cleanser for cleansing soft tissue in the mouth, the cleanser being formed of a resilient material and including a base having a main portion fixed to the first surface and side

62301-2675D1

portions fixed to the sidewalls, and at least one projection protruding outward from the base for removal of microbial and other debris from the soft tissue;

cleaning elements projecting from the second surface of the head and from the side portions of the base for acting on a user's teeth and gums;

5 wherein the cleaning elements projecting from the side portions are formed as one piece with the base;

wherein the base, the at least one projection, and the cleaning elements projecting from the side portions are formed of an elastomer; and

10 wherein a plurality of said bases each in the form of an elongate strip are fixed to the head, each including a plurality of said projections.

6. An oral care implement comprising:

a head having a first surface, an opposite second surface, and sidewalls extending between the first and second surfaces;

a cleanser for cleansing soft tissue in the mouth, the cleanser comprising:

15 a base having a main portion fixed to the first surface;

side portions fixed to the sidewalls;

a plurality of projections protruding outward from the base for removal of microbial and other debris from the soft tissue; and

20 a plurality of cleaning elements projecting from the side portions of the base for acting on a user's teeth and gums;

wherein the plurality of teeth cleaning elements projecting from the side portions are formed as one piece with the base;

62301-2675D1

wherein the base, the plurality of projections, and the plurality of cleaning elements projecting from the side portions are formed of an elastomer; and

wherein the main portion is formed of a plurality of elongate strips and wherein each of the side portions is an extension of one of the elongate strips, each of the plurality of  
5 elongate strips including a plurality of said projections.

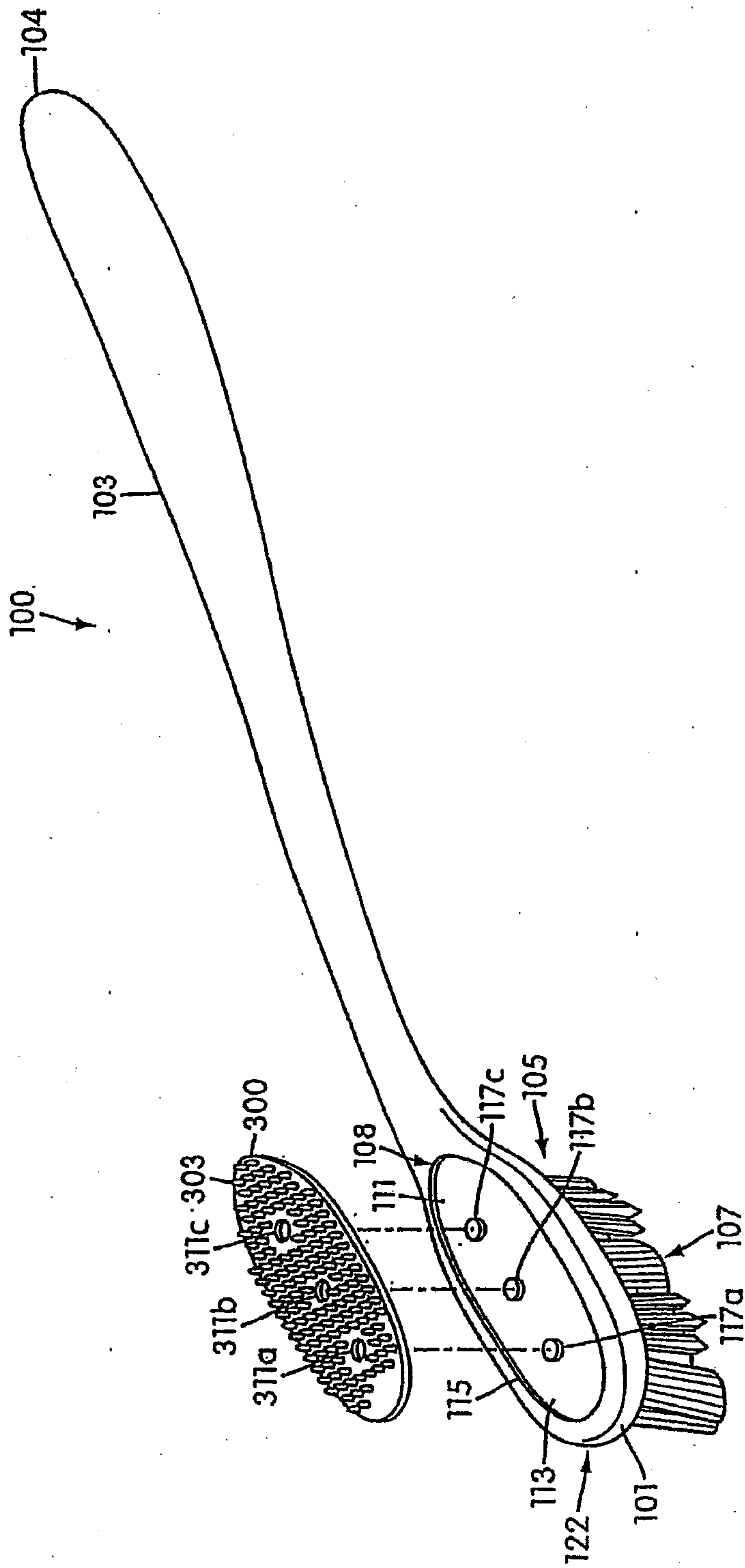

FIG. 1

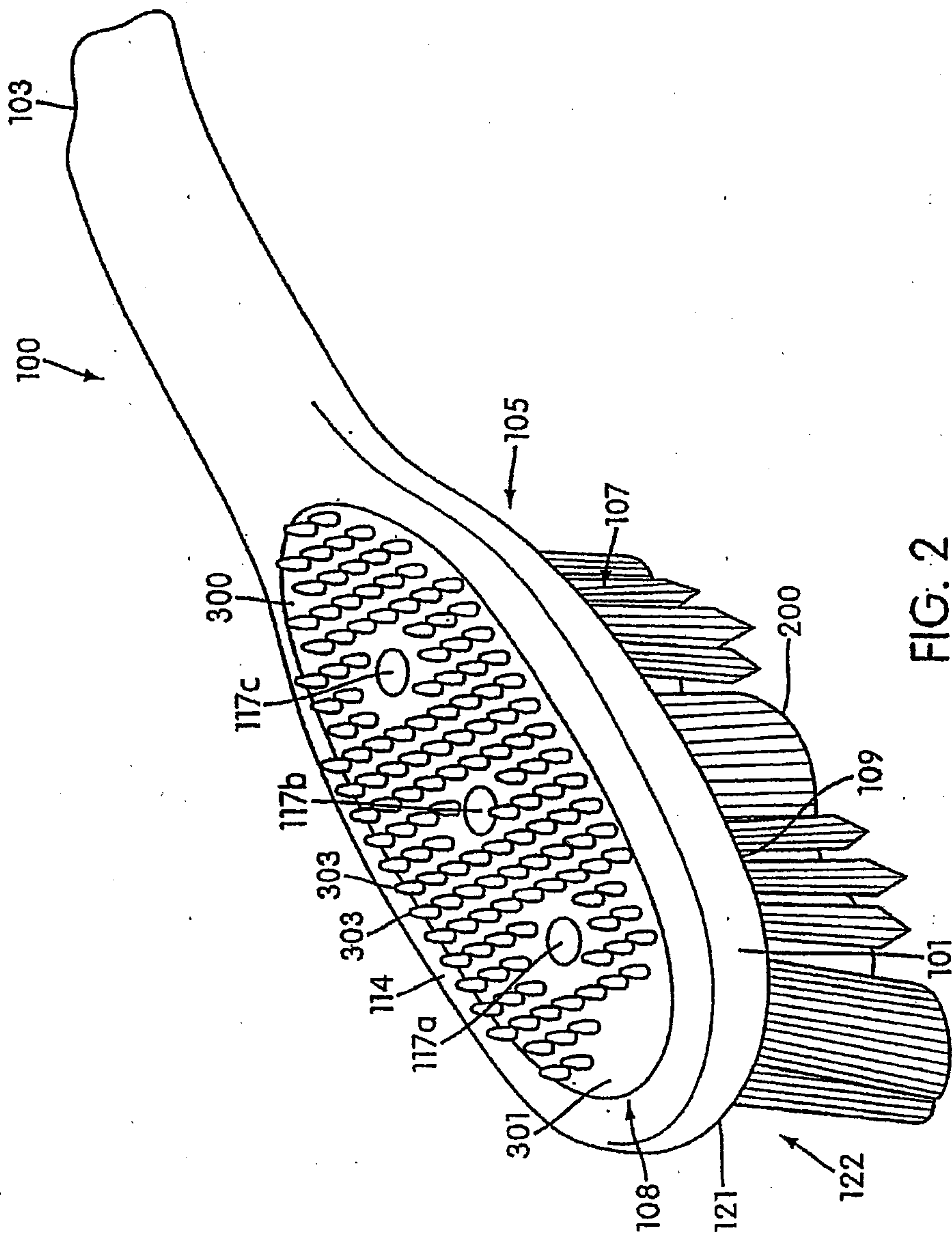
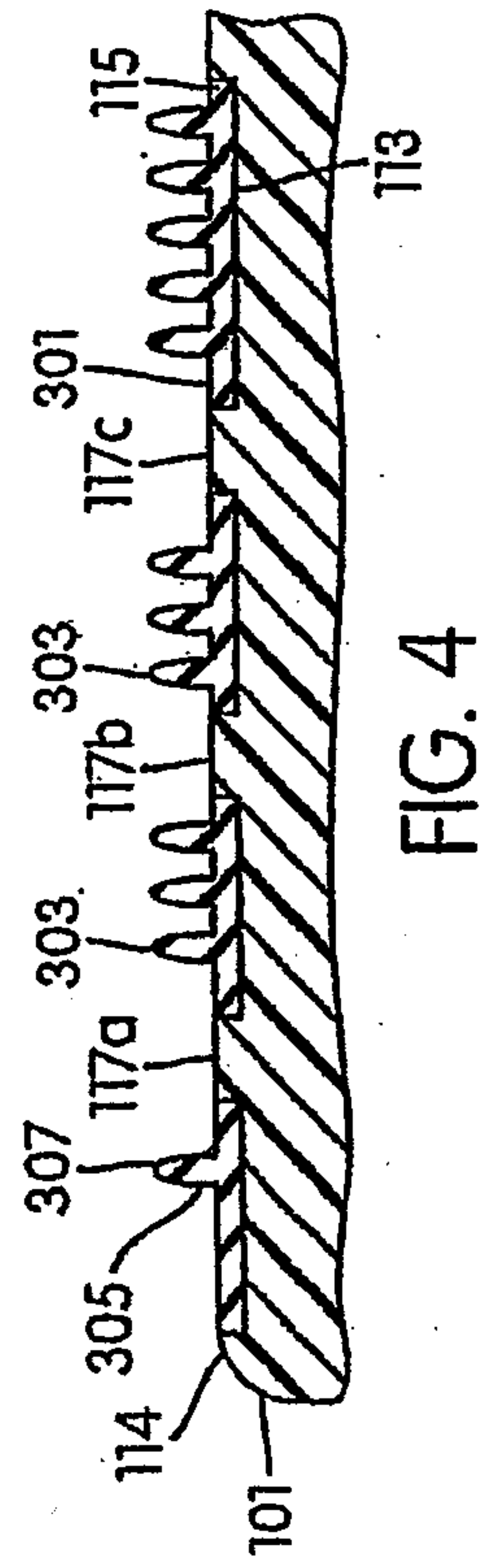
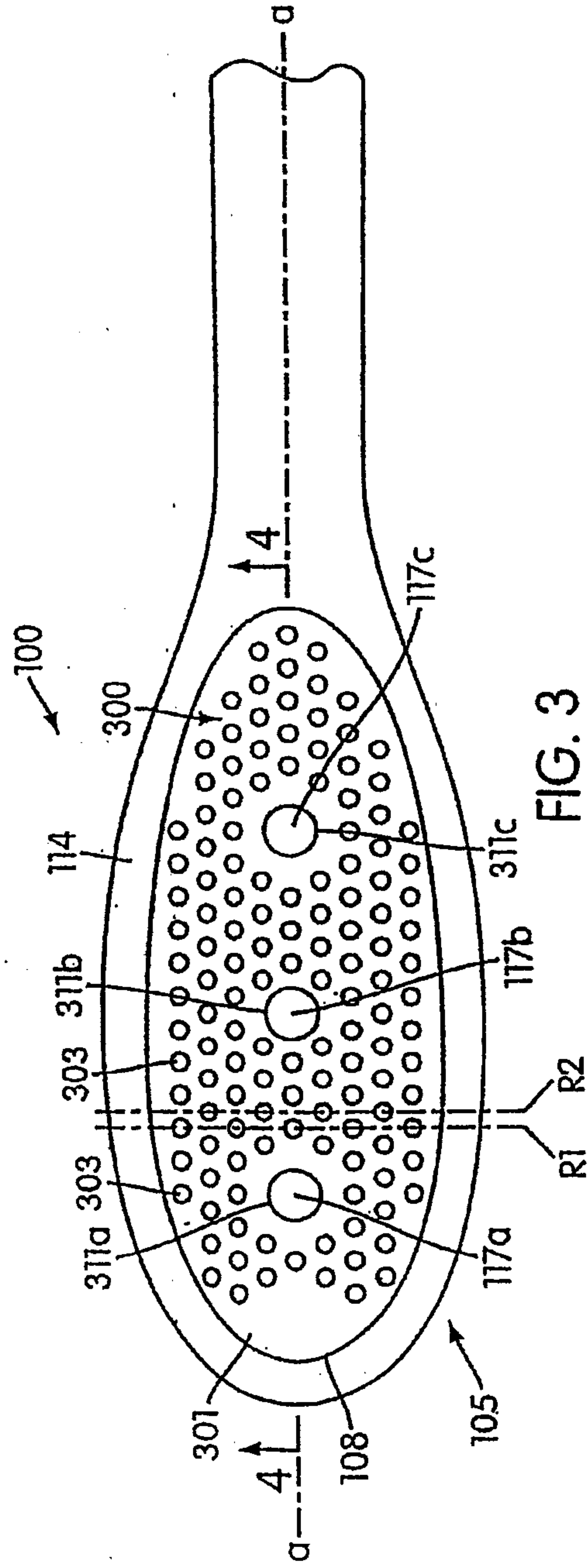

FIG. 2



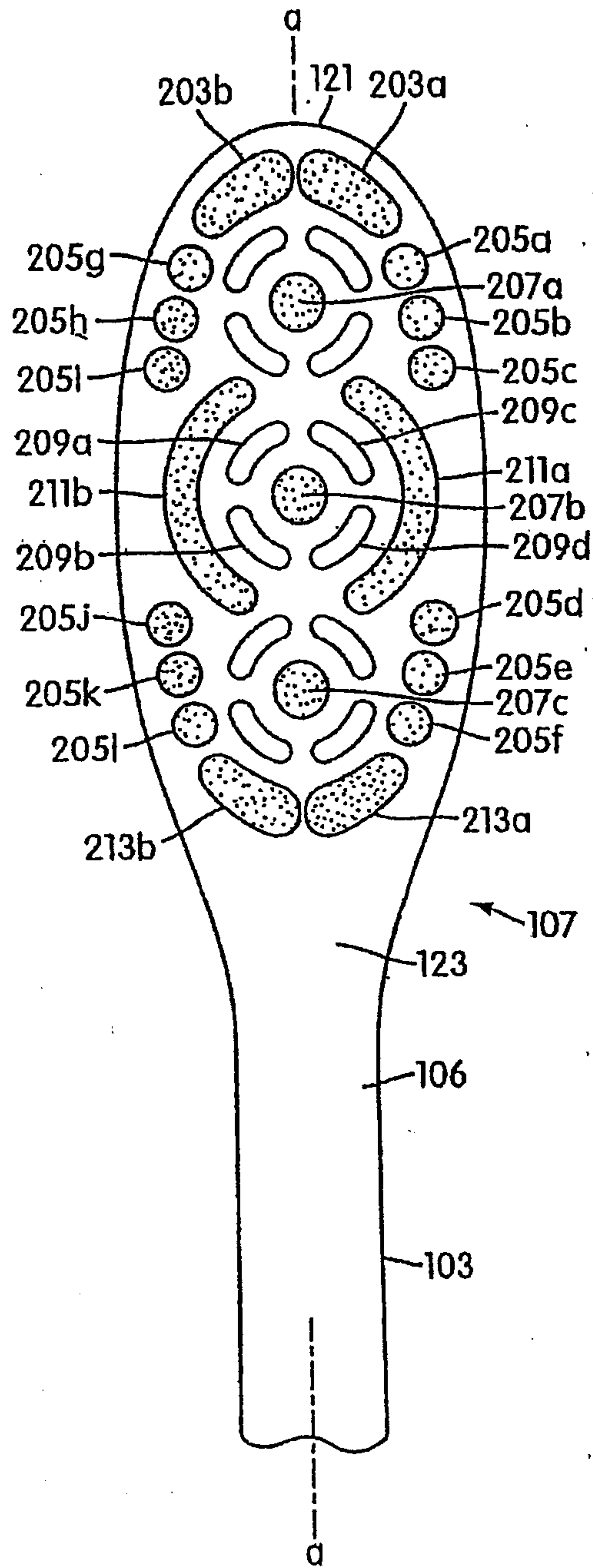

FIG. 5



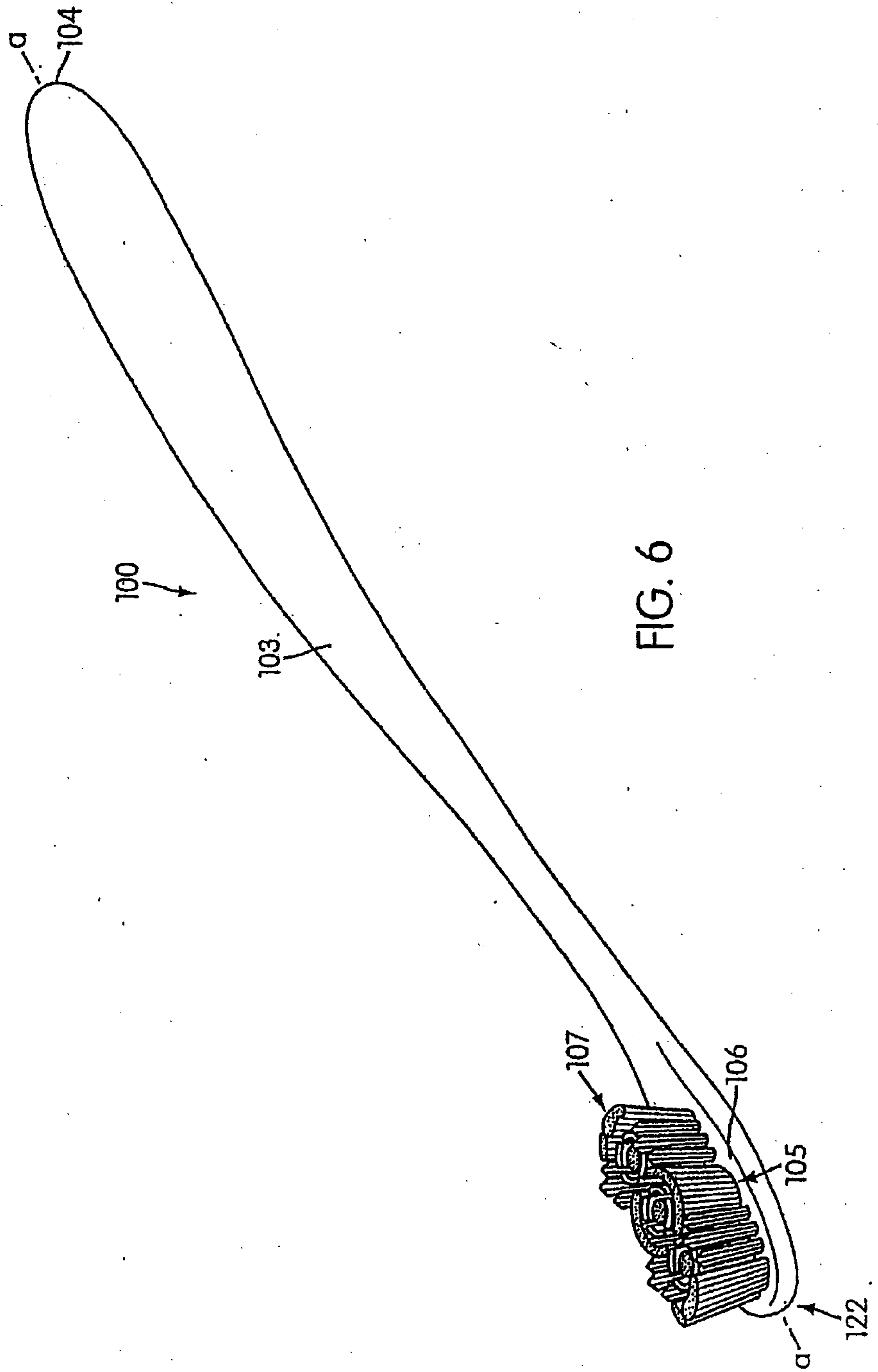

FIG. 6

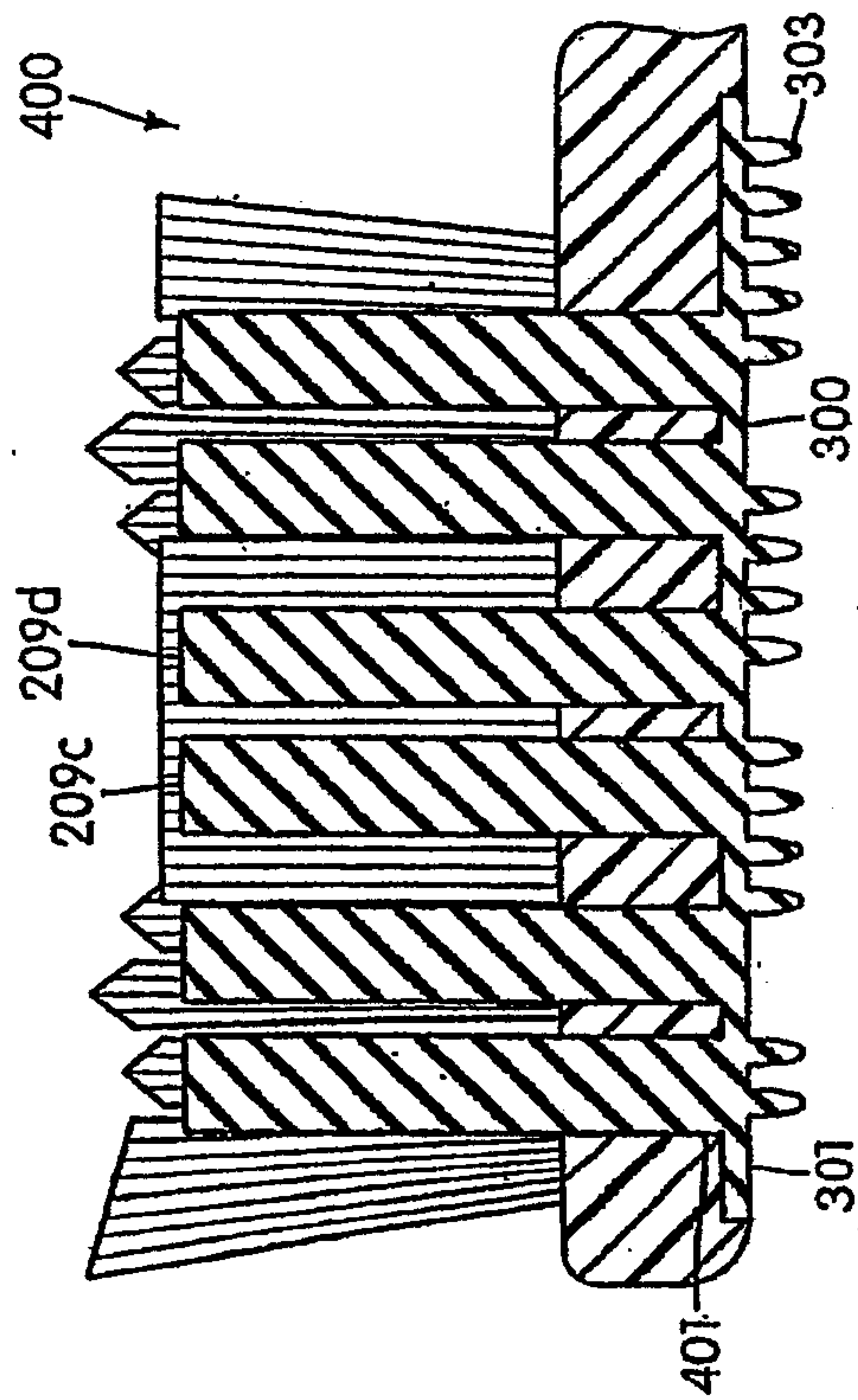

FIG. 7

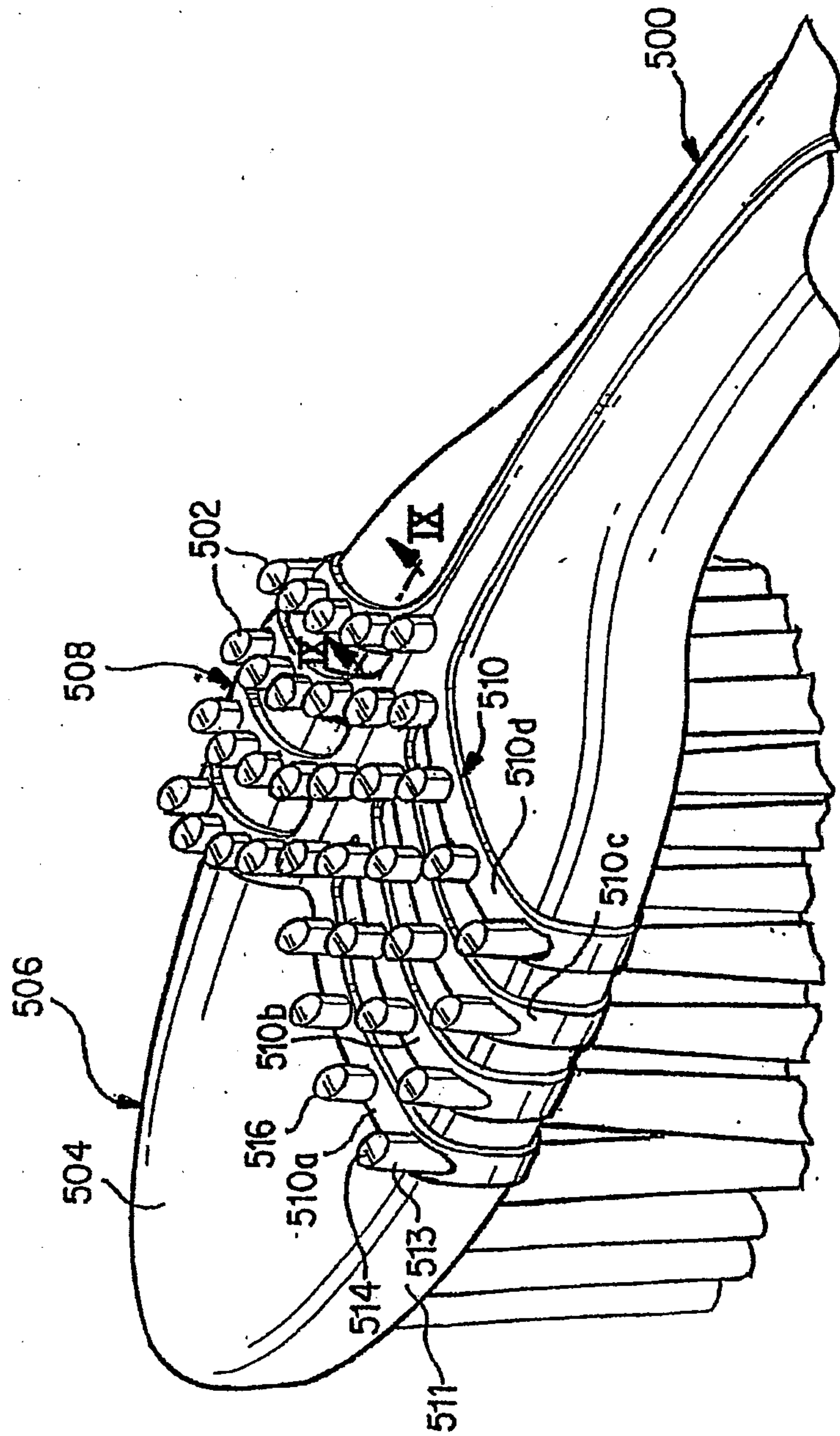

FIG. 8

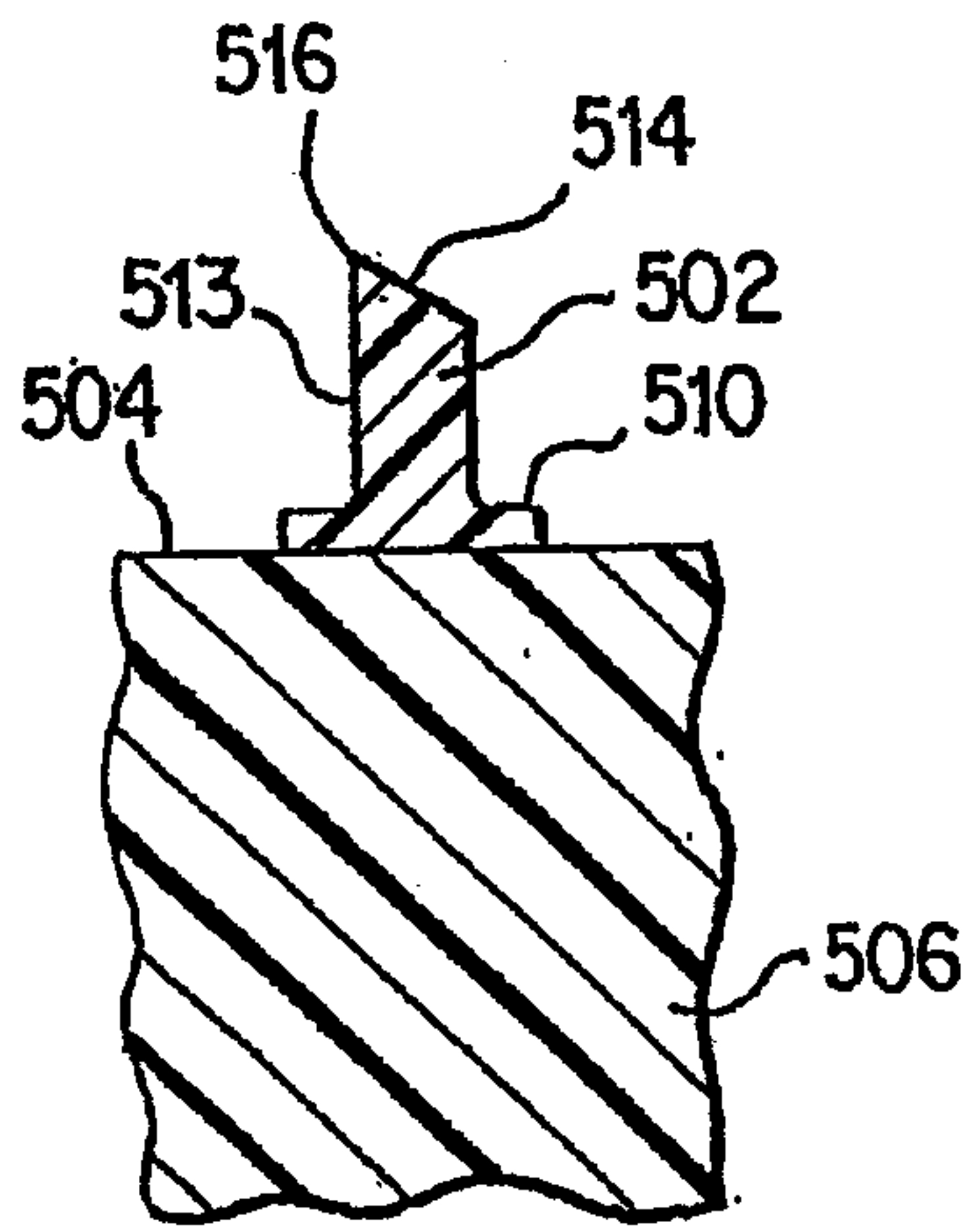

FIG. 9

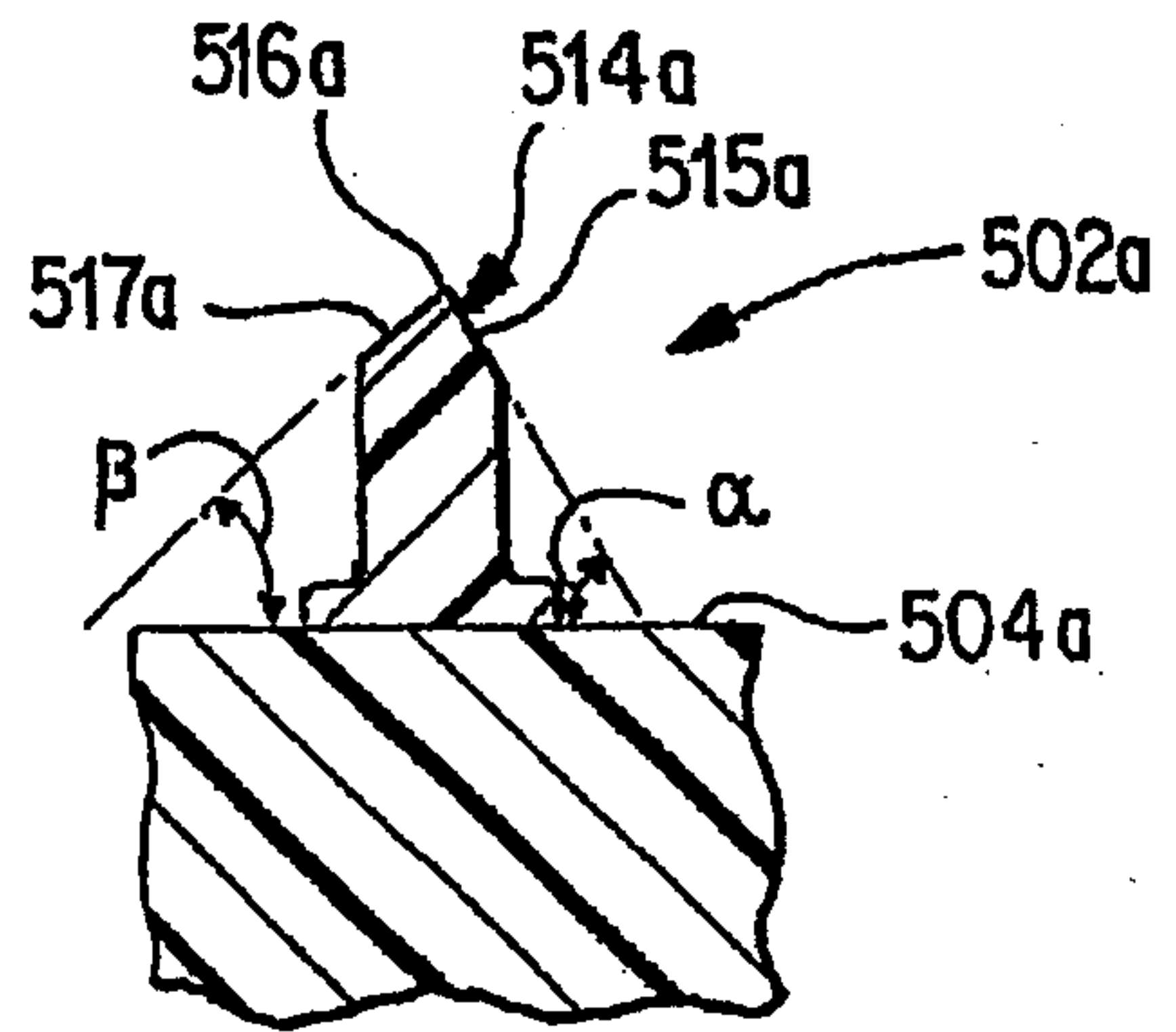

FIG. 10

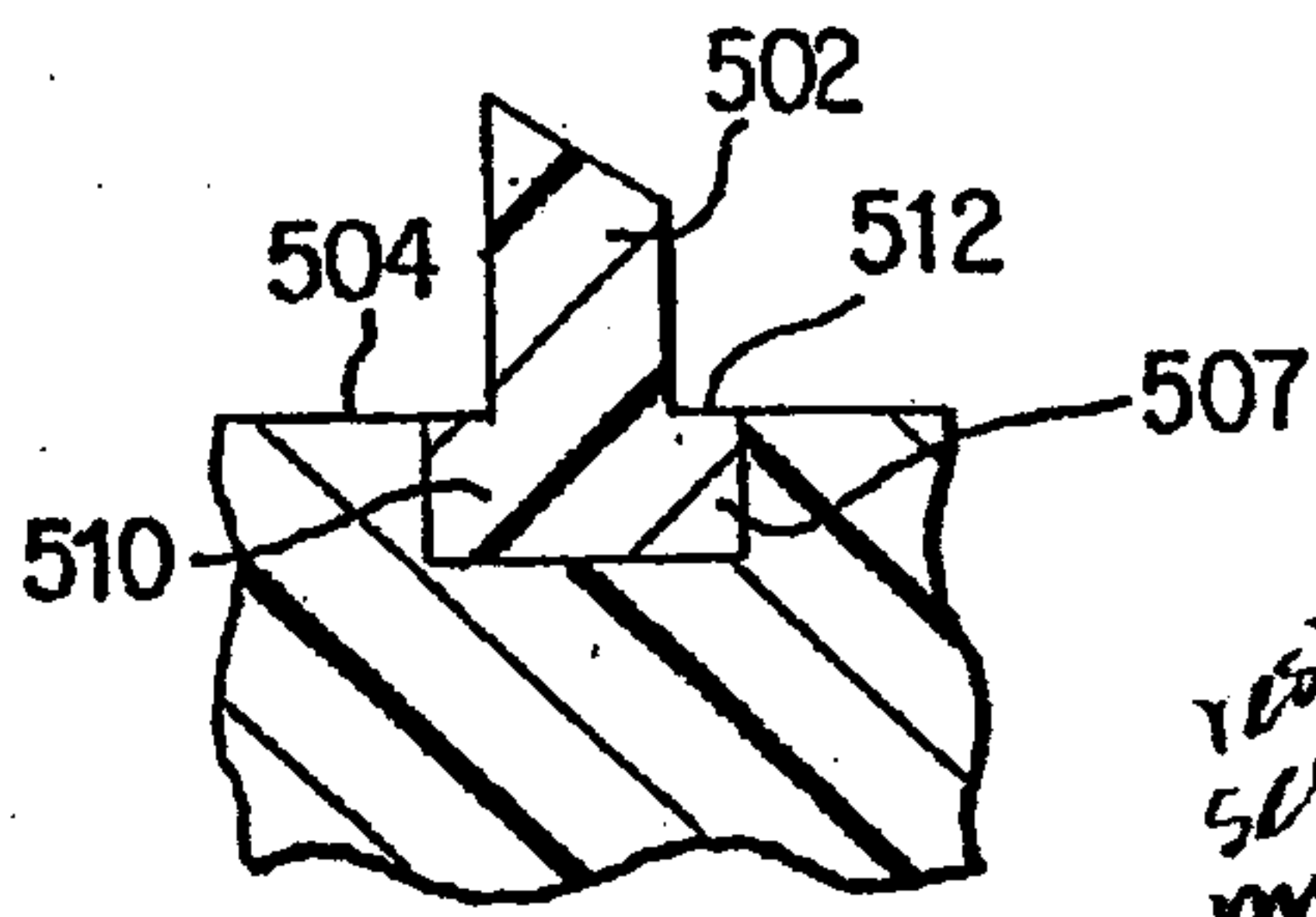

FIG. 11

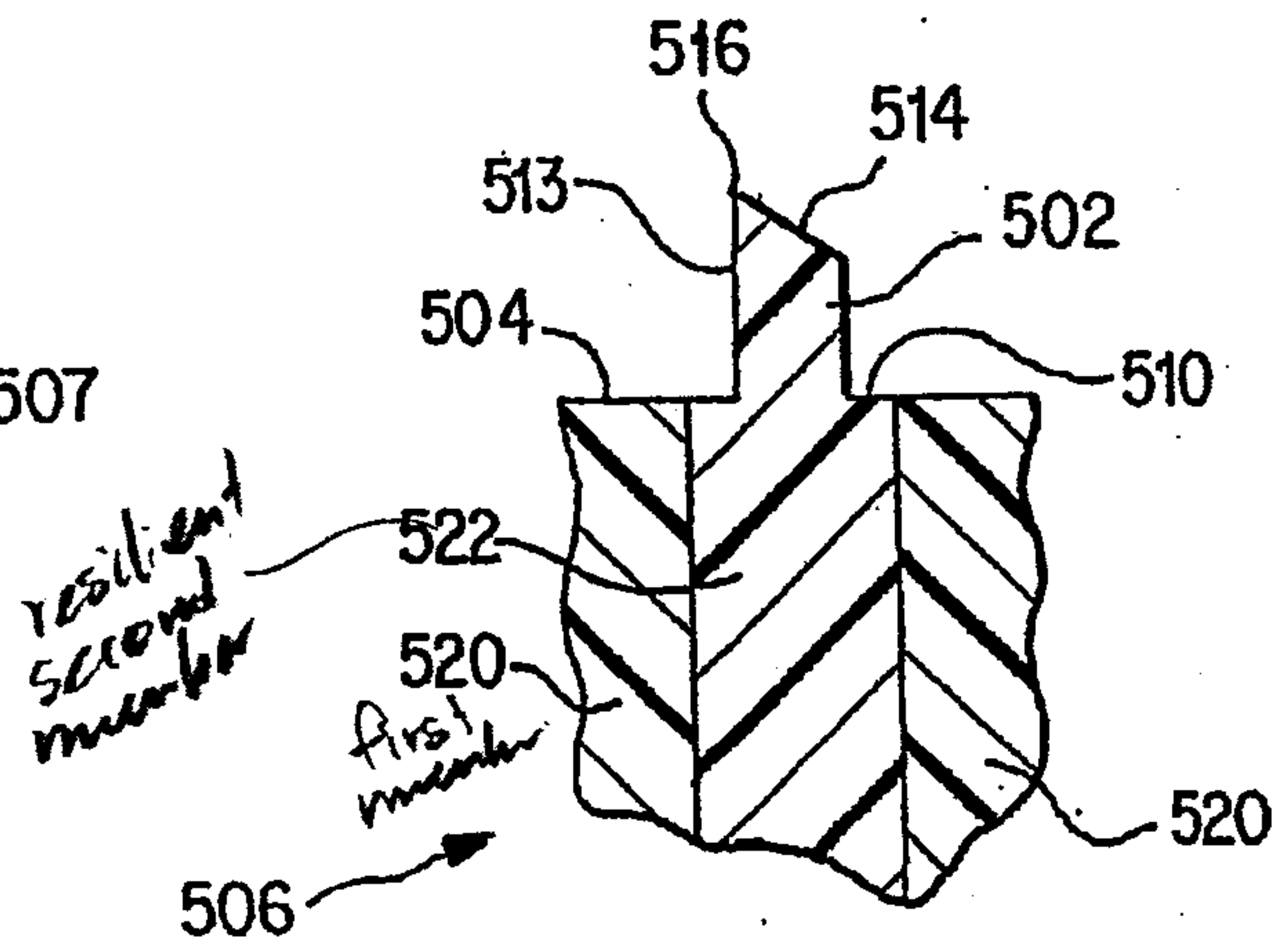

FIG. 12

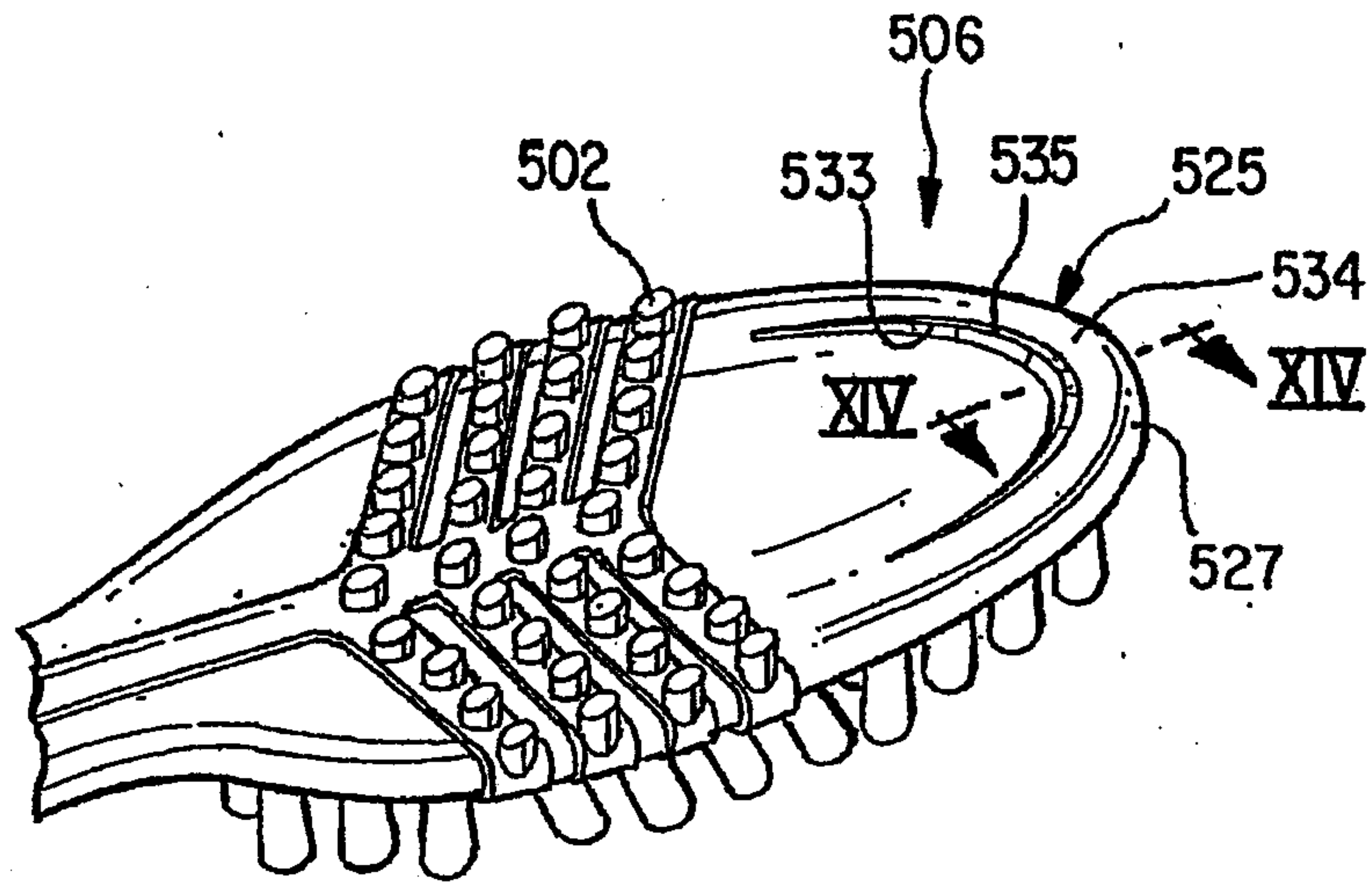

FIG. 13

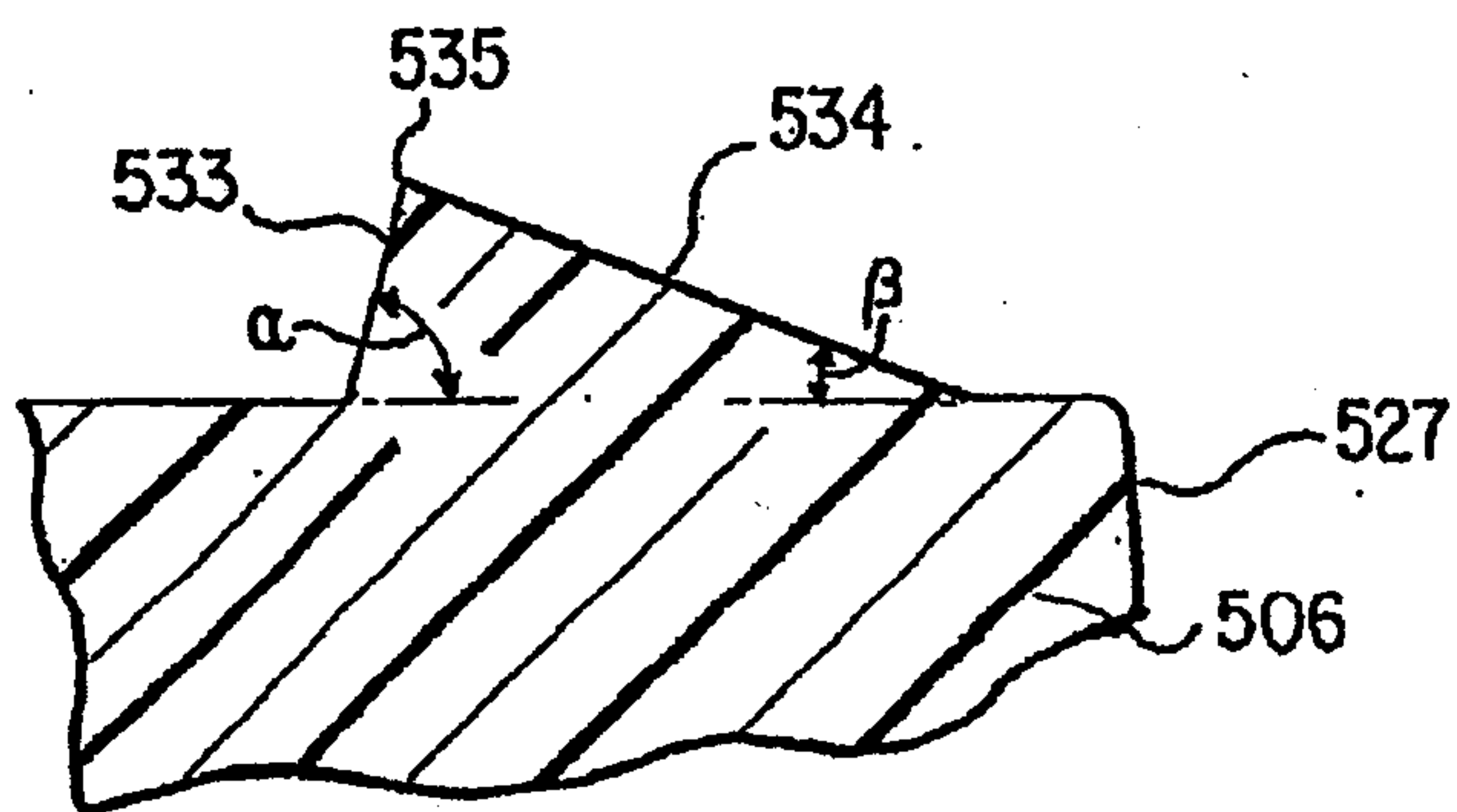

FIG. 14

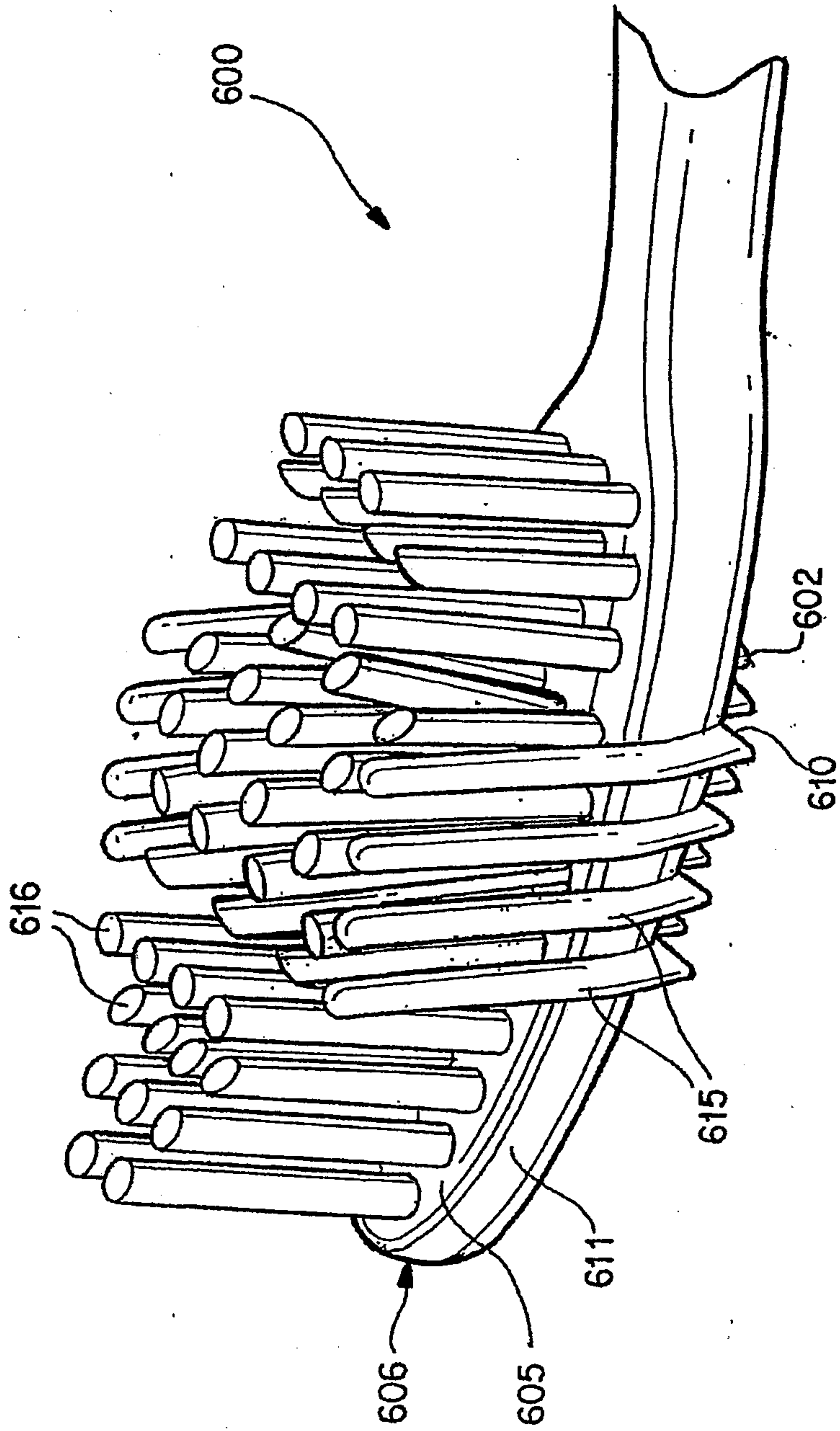

FIG. 15

