

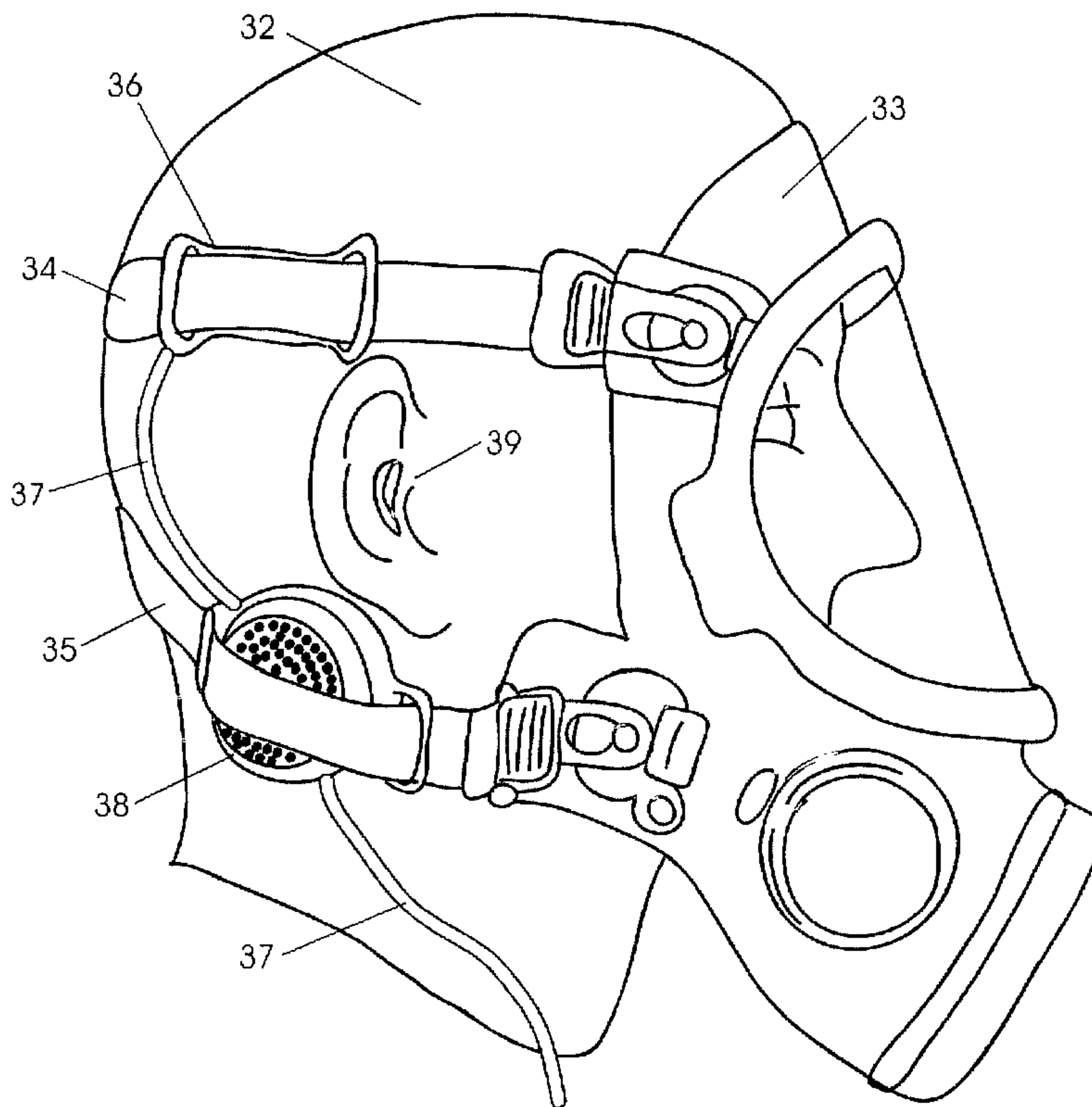

(86) Date de dépôt PCT/PCT Filing Date: 2003/09/05
 (87) Date publication PCT/PCT Publication Date: 2004/03/25
 (85) Entrée phase nationale/National Entry: 2005/02/28
 (86) N° demande PCT/PCT Application No.: AU 2003/001167
 (87) N° publication PCT/PCT Publication No.: 2004/023914
 (30) Priorité/Priority: 2002/09/11 (2002951326) AU

(51) Cl.Int.⁷/Int.Cl.⁷ A42B 3/30
 (71) Demandeur/Applicant:
 INNOTECH PTY LTD, AU
 (72) Inventeur/Inventor:
 MIRANDA, STEPHEN ALFRED, AU
 (74) Agent: PAUL SMITH INTELLECTUAL PROPERTY LAW

(54) Titre : APPAREIL DE COMMUNICATION ET CASQUE
 (54) Title: COMMUNICATION APPARATUS AND HELMET



(57) **Abrégé/Abstract:**

A communication apparatus includes a support structure (41) that is fastenable to a safety helmet (58). A vibration conduction microphone (54) is carried by the support structure. The vibration conduction microphone and the speaker enclosure (43) are positioned so that, when the support structure is fastened to the safety helmet, the vibration conduction microphone and the speaker enclosure come into contact with a rear of the wearer's head.

(12) INTERNATIONAL APPLICATION PUBLISHED UNDER THE PATENT COOPERATION TREATY (PCT)

(19) World Intellectual Property
Organization
International Bureau



(43) International Publication Date
25 March 2004 (25.03.2004)

PCT

(10) International Publication Number
WO 2004/023914 A1

- (51) International Patent Classification⁷: **A42B 3/30** Alfred [AU/AU]; 60-62 Highview Tce, Daisy Hill, QLD 4127 (AU).
- (21) International Application Number: PCT/AU2003/001167 (74) Agent: EAGAR NEWCOMB & BUCK PATENT AND TRADE MARK ATTORNEYS; PO Box 509, Spring Hill, QLD 4004 (AU).
- (22) International Filing Date: 5 September 2003 (05.09.2003) (81) Designated States (*national*): AE, AG, AL, AM, AT, AU, AZ, BA, BB, BG, BR, BY, BZ, CA, CH, CN, CO, CR, CU, CZ, DE, DK, DM, DZ, EC, EE, ES, FI, GB, GD, GE, GH, GM, HR, HU, ID, IL, IN, IS, JP, KE, KG, KP, KR, KZ, LC, LK, LR, LS, LT, LU, LV, MA, MD, MG, MK, MN, MW, MX, MZ, NI, NO, NZ, OM, PG, PH, PL, PT, RO, RU, SC, SD, SE, SG, SK, SL, SY, TJ, TM, TN, TR, TT, TZ, UA, UG, US, UZ, VC, VN, YU, ZA, ZM, ZW.
- (25) Filing Language: English (84) Designated States (*regional*): ARIPO patent (GH, GM, KE, LS, MW, MZ, SD, SL, SZ, TZ, UG, ZM, ZW), Eurasian patent (AM, AZ, BY, KG, KZ, MD, RU, TJ, TM), European patent (AT, BE, BG, CH, CY, CZ, DE, DK, EE,
- (26) Publication Language: English
- (30) Priority Data: 2002951326 11 September 2002 (11.09.2002) AU
- (71) Applicant (*for all designated States except US*): INNOTECH PTY LTD [AU/AU]; Cnr Miles Platting Road & McKechnie Drive, Eight Mile Plains, QLD 4113 (AU).
- (72) Inventor; and
- (75) Inventor/Applicant (*for US only*): MIRANDA, Stephen,

[Continued on next page]

(54) Title: COMMUNICATION APPARATUS AND HELMET

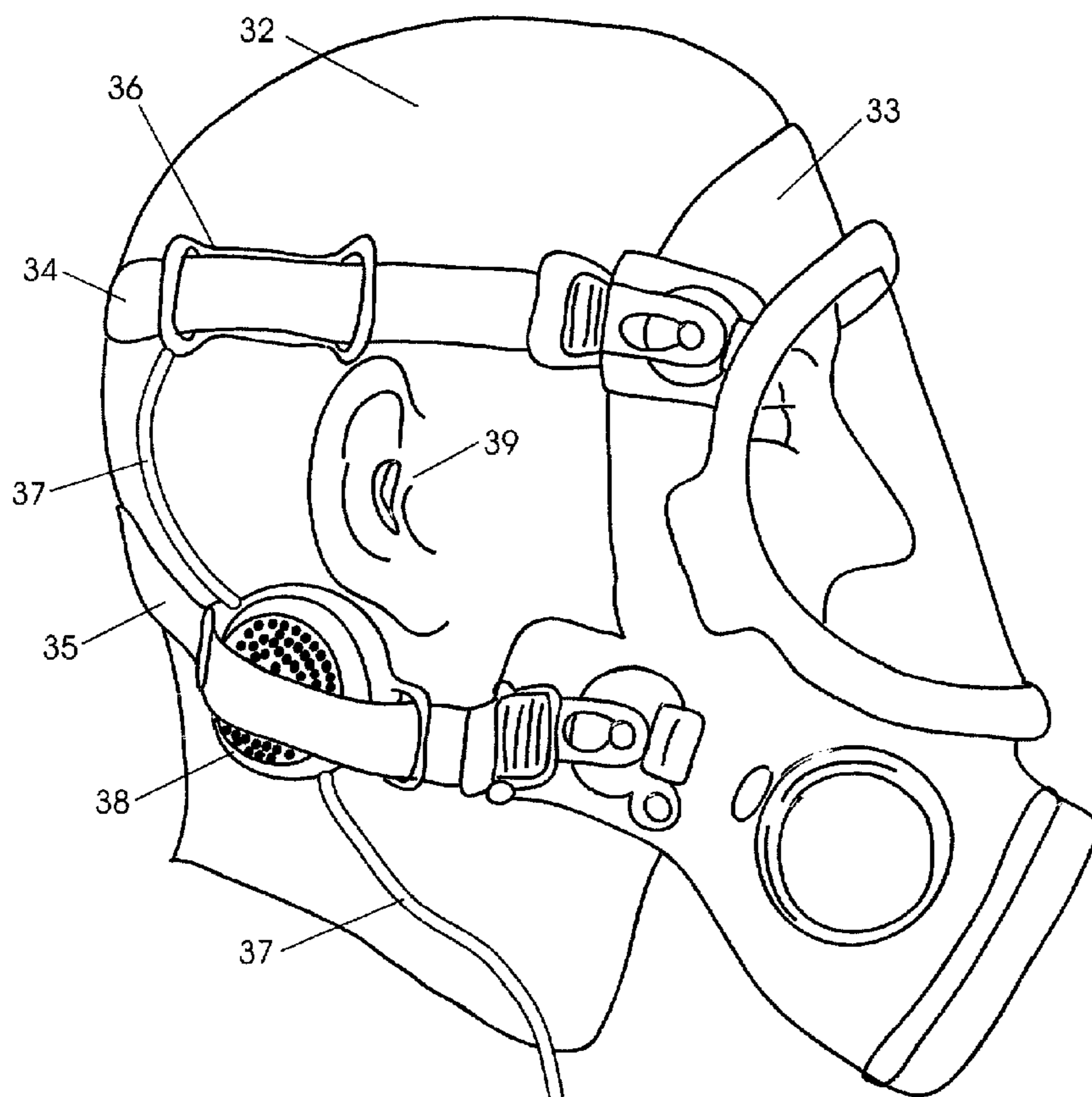

(57) Abstract: A communication apparatus includes a support structure (41) that is fastenable to a safety helmet (58). A vibration conduction microphone (54) is carried by the support structure. The vibration conduction microphone and the speaker enclosure (43) are positioned so that, when the support structure is fastened to the safety helmet, the vibration conduction microphone and the speaker enclosure come into contact with a rear of the wearer's head.

WO 2004/023914 A1

WO 2004/023914 A1



ES, FI, FR, GB, GR, HU, IE, IT, LU, MC, NL, PT, RO,
SE, SI, SK, TR), OAPI patent (BF, BJ, CF, CG, CI, CM,
GA, GN, GQ, GW, ML, MR, NE, SN, TD, TG).

For two-letter codes and other abbreviations, refer to the "Guidance Notes on Codes and Abbreviations" appearing at the beginning of each regular issue of the PCT Gazette.

Published:

— *with international search report*

COMMUNICATION APPARATUS AND HELMET

FIELD OF THE INVENTION

The present invention is concerned with improved means for facilitating
5 communication by workers in noisy and hazardous environments.

BACKGROUND TO THE INVENTION

A problem that is particularly faced by workers, such as fire-fighters, in noisy and
often hazardous environments, is that it is difficult to clearly communicate with fellow
10 workers, and other parties, when wearing apparatus such as helmets and breathing
masks. Several approaches to this problem are described in the prior art. For
example, in Japanese Patent Application publication No. JP 11215581-A to Temco
Japan Co. Ltd, there is described a bone conduction head-set suitable for mounting
under a helmet. The bone conduction microphone is mounted on the top of the head.
15 Such an apparatus is believed to be potentially dangerous as in the event of a load
falling upon a wearer of the apparatus the bone conduction microphone may depress
the wearer's skull. Other approaches to facilitating communication have involved the
use of headphones which cover the ears. While such an approach allows the wearer
to readily hear sound from the headphones it prevents the wearer from hearing
20 ambient noise and engaging in direct communication with those nearby.

Where personnel operate in high ambient noise environments there may be a
need for hearing protection to be used. However, the use of hearing protection
typically interferes with the provision of clear communication.

A further problem that is faced in providing a communication means for
25 firefighters is that the communication means may be damaged by water used by the
firefighters in the course of their work.

It is an objective of the present invention to provide means for addressing the
above described problems.

SUMMARY OF THE INVENTION

According to a first aspect of the present invention there is provided a communication apparatus including:

a support structure that is fastenable to a safety helmet;

5 a vibration conduction microphone that is carried by the support structure; and

a speaker enclosure that is also carried by the support structure, the vibration conduction microphone and the speaker enclosure being positioned so that, when the support structure is fastened to the safety helmet, the vibration conduction microphone and the speaker enclosure come into contact with a rear of a wearer's
10 head, in use.

The support structure may be configured to be fastened to a nape strap of the safety helmet.

Preferably both the vibration conduction microphone and the speaker enclosure are waterproof.

15 According to a second aspect of the invention there is provided a helmet that includes:

a vibration conduction microphone that is positioned on a part of the helmet;

and

a speaker enclosure that is also positioned on a part of the helmet, the
20 vibration conduction microphone and the speaker enclosure being positioned so that when the helmet is worn, the vibration conduction microphone and the speaker enclosure come into contact with a rear of the wearer's head.

According to a third aspect of the present invention there is provided a speaker enclosure including:

25 a housing disposed about a speaker, the housing having at least one opening;

a resilient diaphragm attached to the housing for contact with the head of a person in use; and

a membrane sealing the at least one opening thereby shielding the speaker from water.

30 In a preferred embodiment the housing has first and second openings. The resilient diaphragm may seal the first opening for contact with the head of a person in use and the second opening is sealed by the waterproof membrane.

Preferably the second opening is protected by an acoustically transparent cover.

In a preferred embodiment a cone of the speaker faces the membrane and the acoustically transparent cover.

5 It is desirable that the housing be dimensioned so that in use energy transfer from the speaker to the person via the resilient diaphragm is maximised.

An electrical cable is typically coupled to the speaker.

Preferably the housing includes an aperture and the electrical cable passes through the aperture.

10 It is desirable that the aperture be filled with a sealant.

Preferably the sealant provides strain relief to the electrical cable.

Preferably the housing includes a mounting means that may be configured to receive a strap, belt or the like.

15 A transducer may be located inside the housing adjacent to the resilient diaphragm in order that the speaker enclosure be used to pick-up vibrations from a wearer as well as to transfer vibrations to the wearer. Preferably the transducer is an accelerometer.

20 The accelerometer is preferably acoustically insulated, for example by means of a visco-elastic layer. A spacer may be attached between the visco-elastic layer and the speaker.

According to a fourth aspect of the invention there is provided a vibration conduction microphone including:

a transducer;

an acoustic isolator disposed about the accelerometer; and

25 a housing.

Preferably the acoustic isolator includes a visco-elastic material

Preferably the acoustic isolator further includes a holder for holding the visco-elastic material.

In a preferred embodiment the transducer comprises an accelerometer.

30 In one embodiment the housing is a flexible body of, for example, urethane, configured to receive the accelerometer, acoustic isolator and holder.

The housing may include a mounting means. The mounting means may be configured to receive a strap, belt or the like.

According to another aspect of the present invention there is provided a helmet mountable communications apparatus, including transducing means consisting of a vibration conduction microphone and/or a speaker enclosure;

5 wherein, the transducing means is mounted at the rear of the helmet so that in use the transducing means contacts the rear of a wearer's head.

Preferably the helmet mounting includes both the vibration conduction microphone and the speaker conduction.

10 Preferably the vibration conduction microphone is of the type previously described. Similarly it is preferable that the speaker enclosure is of the type previously described.

The transducing means may be conveniently mounted to, or suspended from, a head support member of the helmet such as an internal headband or nape strap of the helmet.

15 The helmet mounting may be provided in combination with a helmet or alternatively it may be provided separately for retro-fitting to a helmet.

Further preferred features of the invention will be apparent from the following detailed description which will be made with reference to a number of drawings.

BRIEF DESCRIPTION OF THE DRAWINGS

20 In order that this invention may be more readily understood and put into practical effect, reference will now be made to the accompanying drawings which illustrate typical preferred embodiments of the invention:

Figure 1 is a first perspective view of a speaker enclosure according to an embodiment of an aspect of the invention.

25 Figure 2 is a second perspective view of the speaker enclosure of Figure 1.

Figure 3 is a plan view of the speaker enclosure of Figures 1 and 2

Figure 3A is a cross-sectional view of the speaker enclosure of Figures 1 and 2.

30 Figure 4 is a perspective view of a speaker enclosure according to a further embodiment of the invention.

Figure 5 is a plan view of the speaker enclosure of Figure 4

Figure 5A is a cross sectional view of the speaker enclosure of Figures 4 and 5.

Figure 6 is a first perspective view of a vibration conduction microphone according to an embodiment of another aspect of the present invention.

Figure 7 is a second perspective view of the vibration conduction microphone of Figure 6.

Figure 8 is a plan view of the vibration conduction microphone of Figures 6 and 7.

Figure 8A is a cross-sectional view of the vibration conduction microphone of Figures 6 and 7.

Figure 9 depicts a use of the speaker enclosure of Figure 1 and the vibration conduction microphone of Figure 6.

Figure 10 is a first perspective view of a helmet mounting according to a further aspect of the invention.

Figure 11 is a second perspective view of the helmet mounting of figure 10

Figure 12 is a plan view of the helmet mounting of Figures 10 and 11

Figures 12A and 12B are cross sectional views.

Figure 13 is an external view of a typical helmet

Figure 14 is a view of the interior of said typical helmet showing the position of the helmet mounting of Figure 10 in use.

20

DETAILED DESCRIPTION OF PREFERRED EMBODIMENTS

Figure 1 is a perspective view of a first side of a speaker enclosure 50 according to a preferred embodiment of the present invention. The term "speaker enclosure" is used herein to refer to a loaded speaker enclosure, i.e., one including a speaker. The speaker enclosure includes a housing 2 which incorporates a mounting means in the form of slots 3 arranged for securing speaker enclosure 50 to a belt, strap or the like. A cover in the form of a grill 4 covers one end of housing 2. Grill 4 is acoustically transparent due to a number of perforations 5 to allow the escape of sound from a speaker located in the housing 2. A cable 6 protrudes through a port 7 formed in housing 2. Cable 6 is connected to a speaker located in the housing 2 as will be shortly explained.

30

Figure 2 is a further perspective view of the speaker enclosure 50 showing a diaphragm 8 which is incorporated into housing 2 opposite grill 4. Figure 3A is a

cross section through the speaker enclosure showing an internally located speaker 9 with cone 10 facing grill 4 as shown. Between the speaker cone and the grill there is located a waterproof membrane 11. Port 7 is sealed with a waterproof sealant 12 which surrounds cable 6 and provides strain relief to the cable. It will be realised that
5 the inside of speaker enclosure 50 is waterproofed by virtue of membrane 11, diaphragm 8 and sealant 12.

In use, speaker enclosure 50 is mounted to the side of the head, by means of a band or strap through slots 3, so that diaphragm 8 is brought into contact with the side of the head but preferably not over the ear. An electrical signal from some
10 communication source, for example a walkie-talkie radio, is applied by means of cable 6 to speaker 9. In response speaker cone 10 vibrates so that sound may be heard emanating from grill 4. Simultaneously diaphragm 8 vibrates against the side of the head thereby causing the auricles of the ear to vibrate sympathetically and allowing the hearer to perceive communication. The depth of housing 2, indicated by
15 dimension D in Figure 3A, is tuned to maximise the coupling of energy from speaker 9 into the wearer's head via diaphragm 8.

Figure 4 is a perspective view of a speaker enclosure 52 according to a further embodiment of the invention. With reference to Figures 1 to 3A, like reference numerals refer to like parts, unless otherwise specified.

20 Figure 5A is a cross section of speaker enclosure 52. An acoustic isolator 13, which preferably includes a visco-elastic material such as Sorbothane®, surrounds a transducer in the form of accelerometer 14. A preferred accelerometer is the Knowles Corporation's 1771 single axis accelerometer. Acoustic isolator 13 further includes a transducer cup 15 which anchors the visco-elastic material and which is
25 secured to the rear of speaker 16. Cabling 17 from accelerometer 14 runs out through port 18 along with cabling 17 from speaker 16. A resilient diaphragm 19 forms part of housing 2 as previously described.

In use, resilient diaphragm 19, is placed against the head of a person. In order to transmit a voice signal to the person, speaker 16 is appropriately energised.
30 Vibrations from the speaker are transmitted via resilient diaphragm 19 into the head of the person where they cause sympathetic vibration of the auricles thereby causing the person to perceive the voice signal via bone-based sound conduction. Sound waves generated by speaker 16 also emanate out through membrane 20 and grill 21

and are heard by the person in the normal way. Conversely when the person speaks vibrations pass through resilient diaphragm 19, are picked up by accelerometer 14 and transduced into an electrical signal that is conveyed by cable 17 for further processing. Accelerometer 14 is prevented from picking-up spurious external sounds
5 by acoustic isolator 13.

Figure 6 is a perspective view of a vibration conduction microphone 54 according to a preferred embodiment of a further aspect of the present invention. Figure 7 is a second perspective view of vibration conduction microphone 54, Figure 8A is a cross sectional view of the vibration conduction microphone 54.

10 Housing 22 has slots 23 for receiving a strap or belt for mounting microphone 54 to the head of a wearer and incorporates a diaphragm 24. Preferably housing 22 is a flexible body of, for example, urethane. Housing 22 has a recess 26.

An acoustic isolator 25 which includes a visco-elastic material such as Sorbothane, surrounds a transducer in the form of an accelerometer 27. A preferred
15 accelerometer is the Knowles Corporation's 1771 single axis accelerometer. Acoustic isolator 25 is a transducer holder in the form of cup 28 which is secured into recess 26 by means of waterproof sealant (not shown). A cable 29 protrudes through a port 30 formed in housing 22. Cable 29 is connected to accelerometer 27 for conveying electrical signals generated by the accelerometer during use for
20 processing. A flexible waterproof sealant 31 seals port 30. It will be realised that the inside of housing 22 is waterproofed by virtue of diaphragm 24 and sealant 31.

In use vibration conduction microphone 54 is secured to the head of a wearer by threading a belt or strap through slots 23 and securing it with diaphragm 24
25 against the wearer's head. As the wearer speaks, vibrations corresponding to the speech are produced and these are conveyed to the accelerometer 27 which converts them into electrical signals that are conveyed by cable 29 for processing by suitable electronic circuitry.

Figure 9 shows a person 32 wearing a typical breathing apparatus mask 33 that includes a number of head support straps 34 and 35. Attached to strap 34 is a
30 vibration conduction microphone 36, of the type described with reference to Figure 6. Attached to strap 35 is a speaker enclosure of the type described with reference to Figure 1. Cabling 37 from microphone 36 and the speaker enclosure 38 is connected to suitable electronic communication modules (not shown).

The communication modules may include signal conditioning circuitry such as filters to improve the clarity of the communications. It will be noted that the wearer's ear 39 is not covered by speaker enclosure 38 so that the wearer may readily hear ambient sound or wear hearing protection in areas of high ambient noise.

5 Figure 10 is a first perspective view of a communication apparatus 56 according to an embodiment of a further aspect of the present invention.

Figure 11 is a second perspective view of communication apparatus 56. Figure 12A is a cross-sectional view of a speaker enclosure 43 of the apparatus 56. Enclosure 43 is similar to enclosure 50. Figure 12B is a cross-sectional view of a
10 vibration conduction microphone 42 of the apparatus 56. Vibration conduction microphone 42 is similar to the microphone 54. It follows that, with reference to Figures 1 to 9, like reference numerals refer to like parts, unless otherwise specified.

Communication apparatus 56 includes a support structure 41 (shown as a helmet mount in Figure 14). As can be seen in Figures 10 to 12, the speaker
15 enclosure 43 and the microphone 42 are positioned in the support structure 41.

Figure 13 is an external view of a typical helmet 58 as used, for example, by fire fighters. Figure 14 is a view of the interior of said typical helmet 58 showing the positioning of the helmet mountable communication apparatus of Figure 10.

Communication apparatus 56 is suspended from a nape adjustment strap 40
20 of helmet 58. Support structure 41 is configured to be connected to nape adjustment strap 40. Speaker enclosure 43 and microphone 42 are positioned on support structure 41 so that diaphragm 24 of vibration conduction microphone 42 and diaphragm 8 of speaker enclosure 43 make contact with the rear of the wearer's head.

25 The inventors have discovered that the vibration conduction microphone and/or the speaker enclosure may be located at the rear of the head. As discussed previously, this location is in contrast to prior art approaches which mount bone conduction transducers at the top of the head which is a potentially dangerous position. As is also the case with the arrangement depicted in Figure 14, the wearers
30 ear is not covered by incorporated speaker enclosure so that the wearer may readily hear ambient sound or wear hearing protection in areas of high ambient noise. The inventors have discovered, somewhat surprisingly, that a speaker enclosure and/or

bone conduction microphone according to the invention works well when mounted as shown in Figure 14.

The embodiments of the invention described herein are provided for purposes of explaining the principles thereof, and are not to be considered as limiting or
5 restricting the invention since many modifications may be made by the exercise of skill in the art without departing from the scope of the invention as defined in the appended claims.

Claims:

1. A communication apparatus including:
 - a support structure that is fastenable to a safety helmet;
 - a vibration conduction microphone that is carried by the support structure; and
 - a speaker enclosure that is also carried by the support structure, the vibration conduction microphone and the speaker enclosure being positioned so that, when the support structure is fastened to the safety helmet, the vibration conduction microphone and the speaker enclosure come into contact with a rear of a wearer's head, in use.
2. A communication apparatus as claimed in claim 1, in which the support structure is configured to be fastened to a nape strap of the safety helmet.
3. A communication apparatus as claimed in claim 1, in which both the vibration conduction microphone and the speaker enclosure are waterproof.
4. A helmet that includes:
 - a vibration conduction microphone that is positioned on a part of the helmet;
 - and
 - a speaker enclosure that is also positioned on a part of the helmet, the vibration conduction microphone and the speaker enclosure being positioned so that when the helmet is worn, the vibration conduction microphone and the speaker enclosure come into contact with a rear of the wearer's head.
5. A speaker enclosure that includes:
 - a housing for a speaker, the housing defining at least one opening;
 - a resilient diaphragm that is attached to the housing and that is configured to make contact with the head of a person, in use; and
 - a membrane that is arranged on the housing to seal the at least one opening so that the speaker is shielded from water.

6. A speaker enclosure as claimed in claim 5, in which the housing defines first and second openings.
7. A speaker enclosure as claimed in claim 6, in which the resilient diaphragm is arranged on the housing to seal the first opening and the membrane is arranged on the housing to seal the second opening.
8. A speaker enclosure as claimed in claim 6 or claim 7, in which an acoustically transparent cover is positioned on the housing to protect the second opening.
9. A speaker enclosure as claimed in any one of claims 5 to 8, in which a speaker is mounted in the housing and an electrical cable is connected to the speaker to transmit electrical signals to the speaker, the housing defining an aperture for accommodating the electrical cable and a sealant being interposed between the cable and the housing, the sealant being selected to provide strain relief to the electrical cable.
10. A speaker enclosure as claimed in claim 9, in which a mounting means is arranged on the housing, the mounting means being configured to receive a strap, belt or the like.
11. A speaker enclosure as claimed in claim 9 or claim 10, in which a transducer is arranged in the housing adjacent the resilient diaphragm so that the speaker enclosure can be used to pick up vibrations from a wearer as well as to transfer vibrations to the wearer.
12. A vibration conduction microphone that includes:
 - a housing;
 - a transducer that is positioned in the housing; and
 - an acoustic isolator that is also positioned in the housing, the acoustic isolator being disposed about the transducer.

13. A vibration conduction microphone according to claim 12, wherein the acoustic isolator includes a visco-elastic material.

14. A vibration conduction microphone according to claim 13, wherein the acoustic isolator further includes a holder for holding the visco-elastic material.

15. A vibration conduction microphone according to claim 14, wherein the transducer comprises an accelerometer.

16. A vibration conduction microphone according to claim 15, wherein the housing comprises a flexible body configured to receive the accelerometer, acoustic isolator and holder.

17. A helmet mountable communications apparatus, including transducing means consisting of a vibration conduction microphone and/or a speaker enclosure;
wherein, the transducing means is mounted at the rear of the helmet so that in use the transducing means contacts the rear of a wearer's head.

18. A helmet mountable communications apparatus according to claim 17 including both the vibration conduction microphone and the speaker conduction.

19. A helmet mountable communications apparatus according to claim 18 wherein the vibration conduction microphone comprises a vibration conduction microphone according to any one of claims 12 to 16.

20. A helmet mountable communications apparatus according to claim 18 wherein the speaker enclosure comprises a speaker enclosure according to any one of claims 5 to 11.

21. A helmet mountable communications apparatus according to claim 18 wherein the transducing means is mounted to an internal support of the helmet.

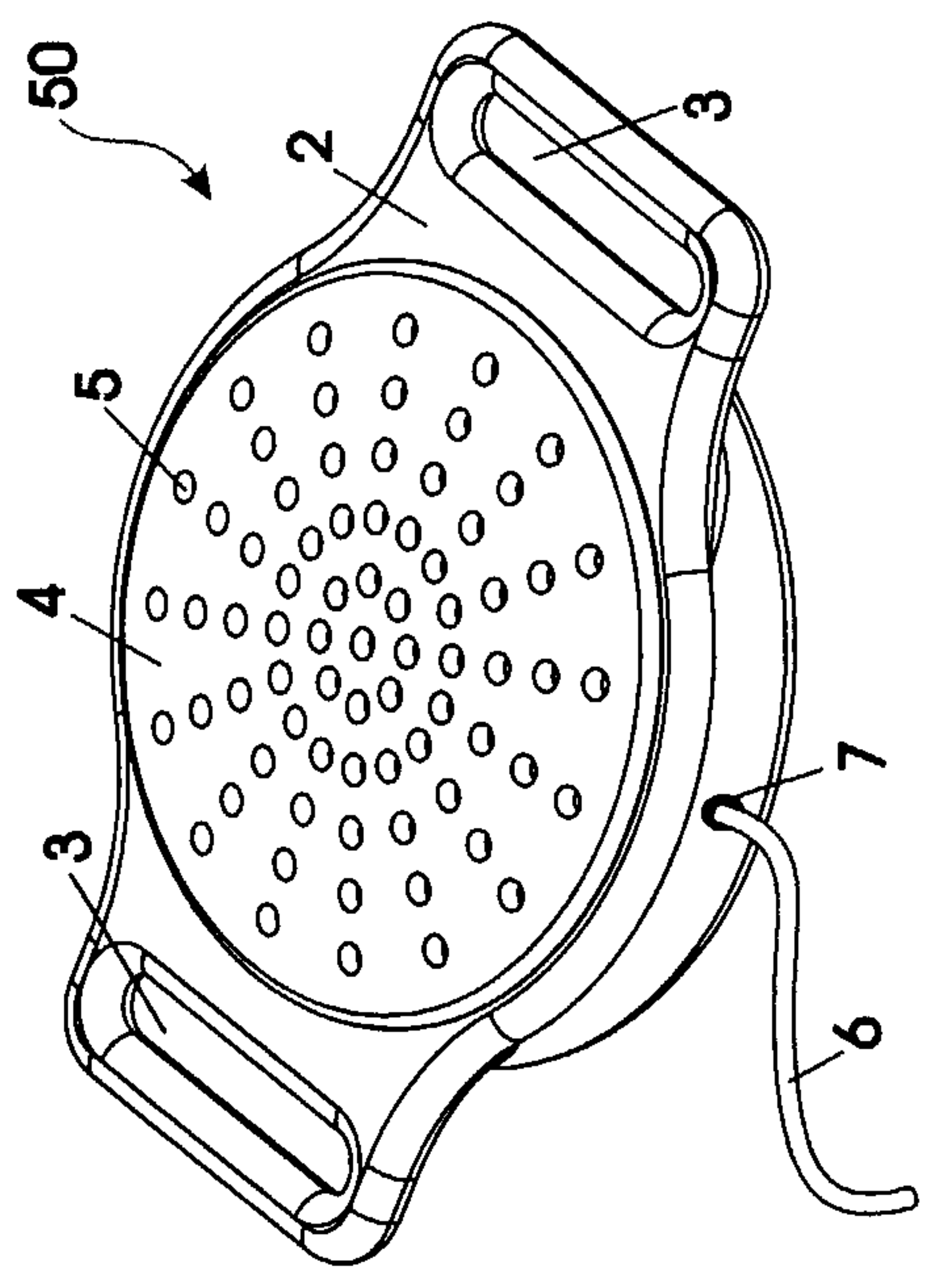

Figure 1

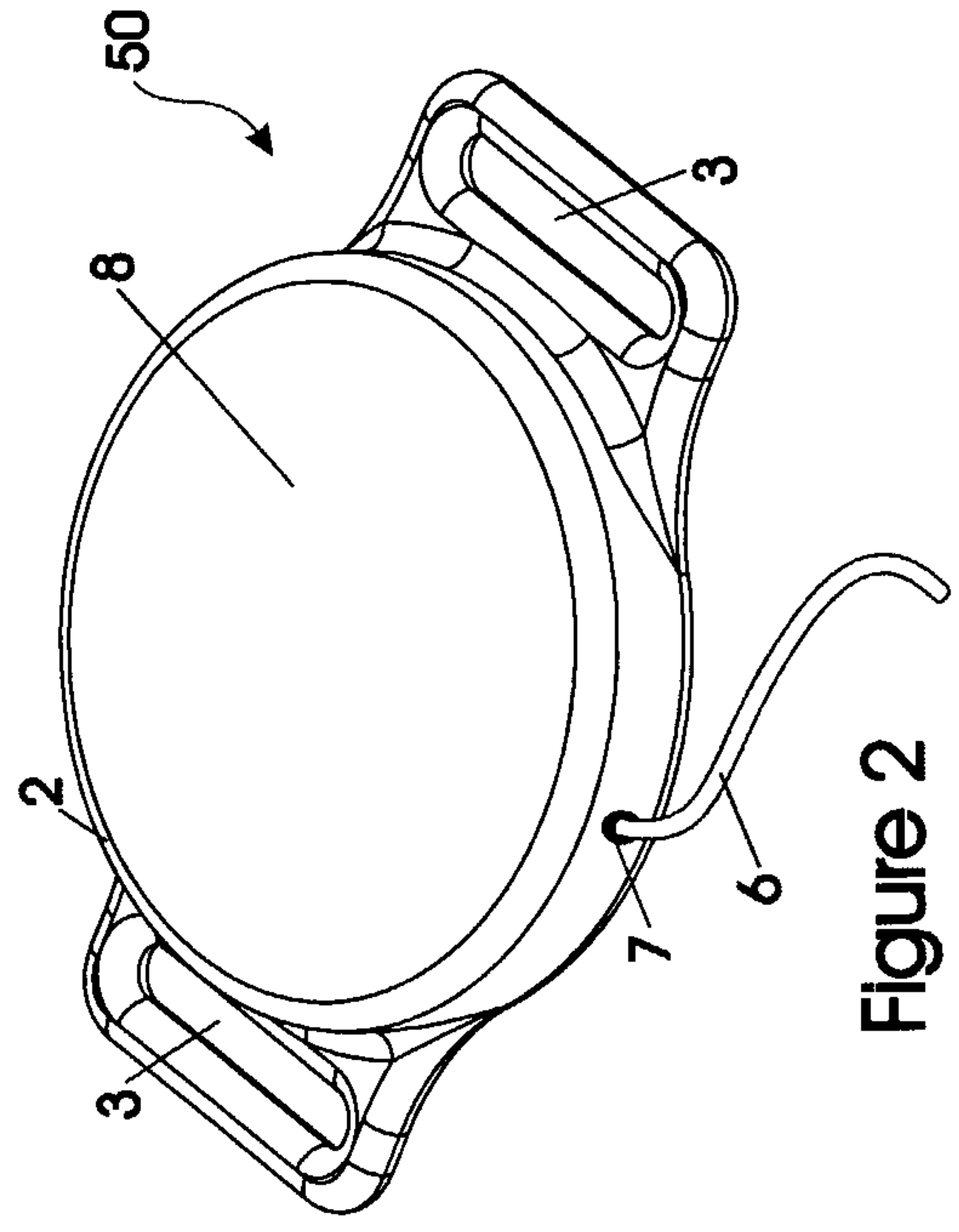

Figure 2

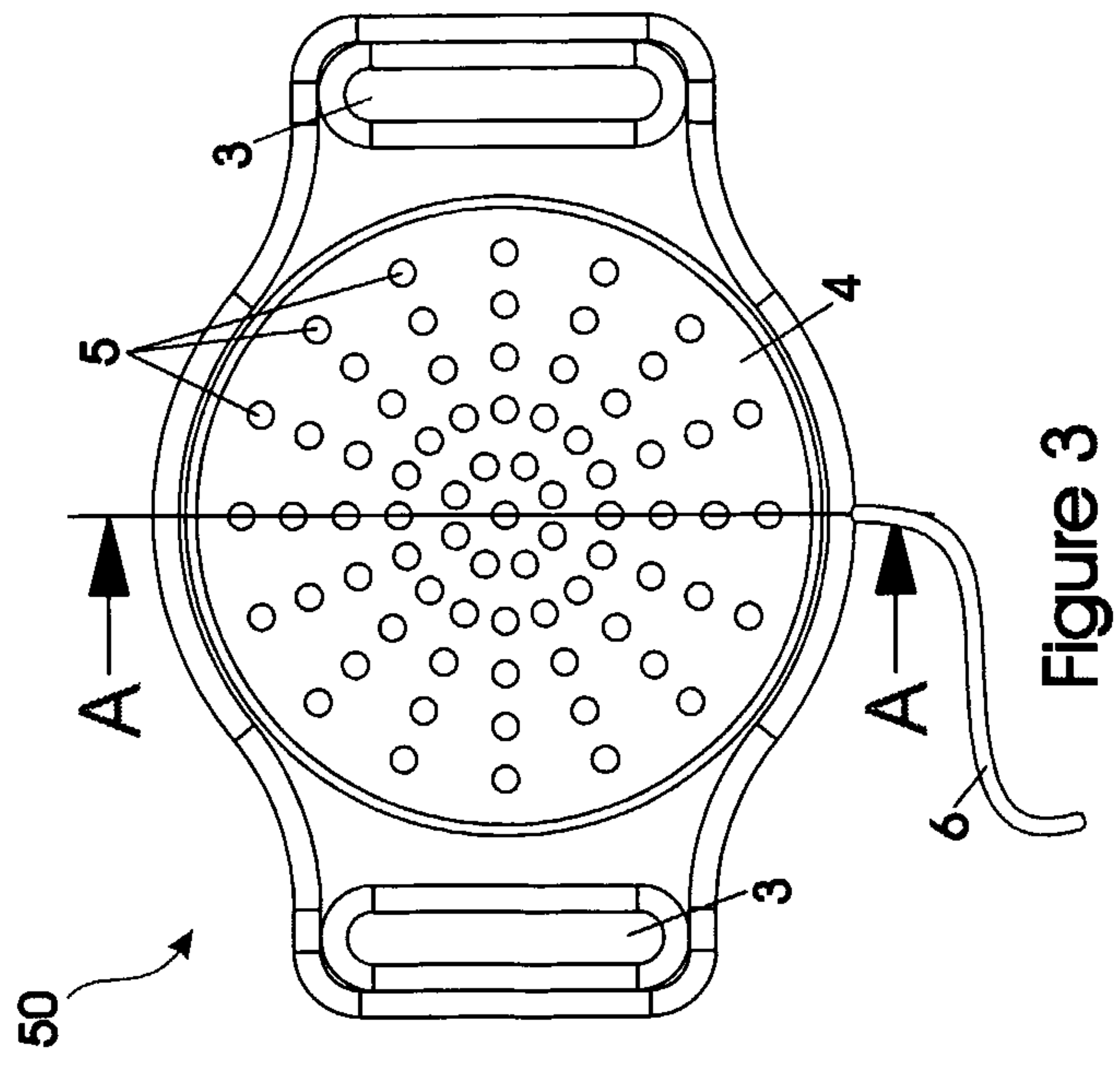

Figure 3

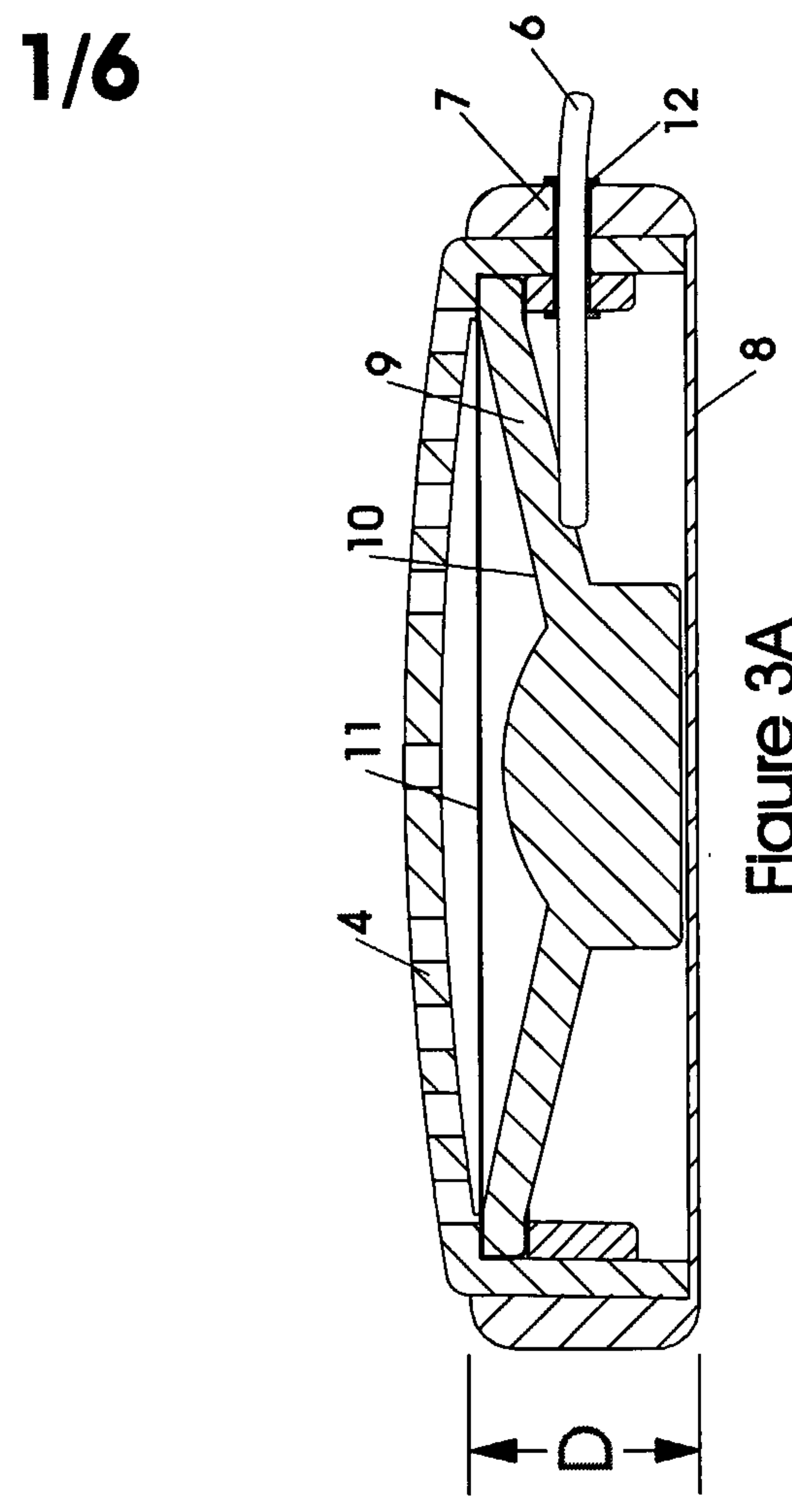

Figure 3A

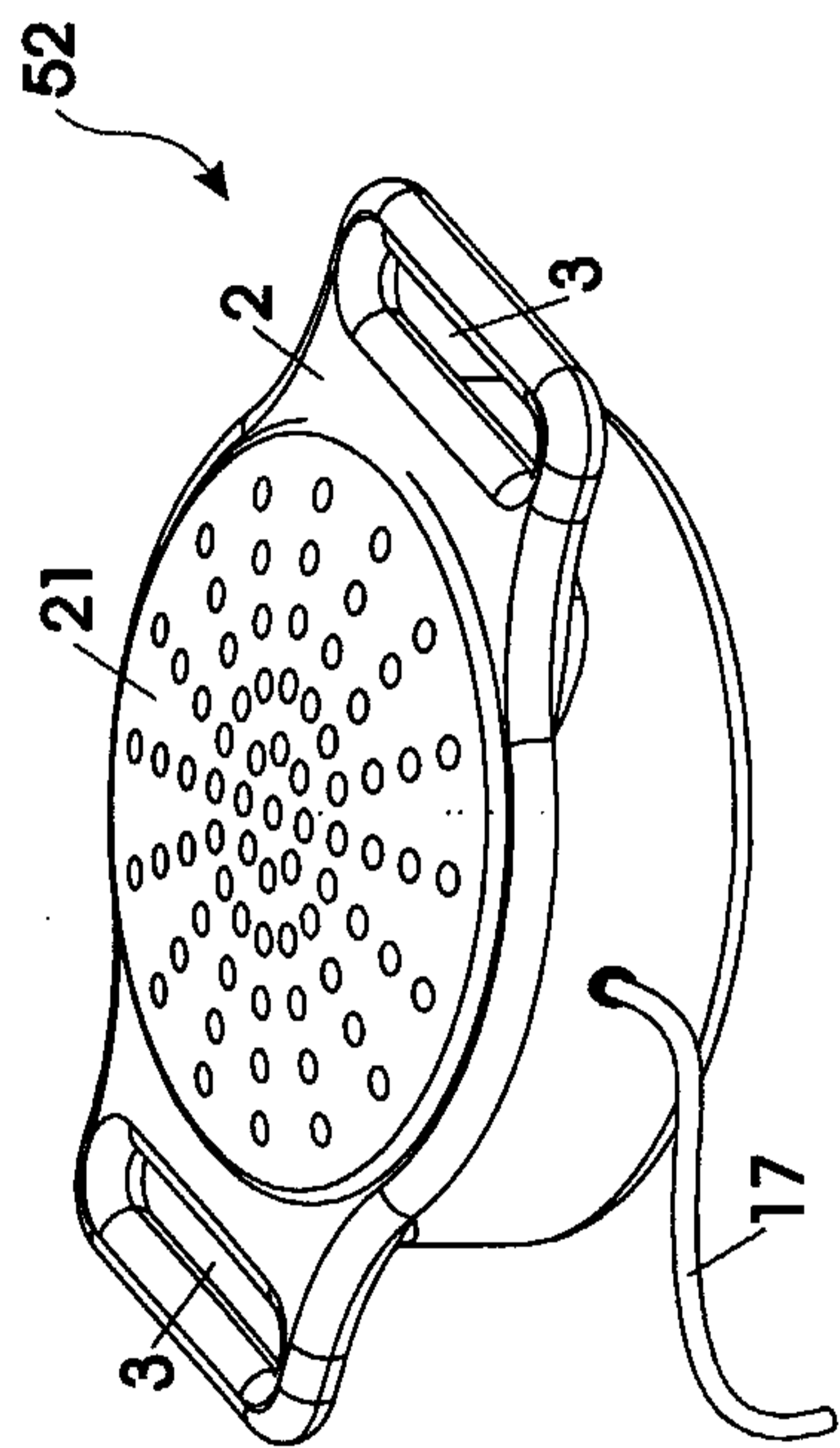

Figure 4

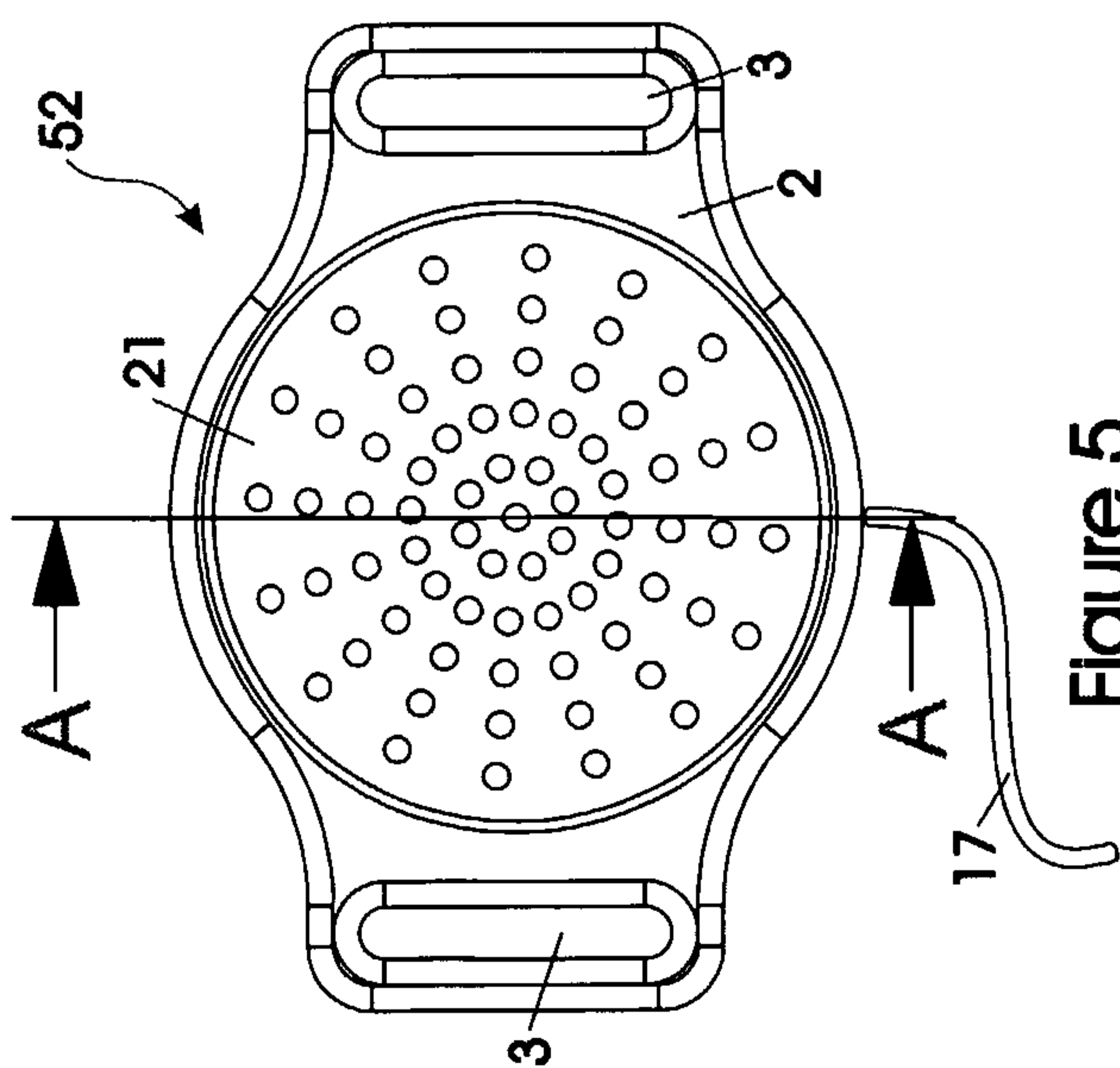

Figure 5

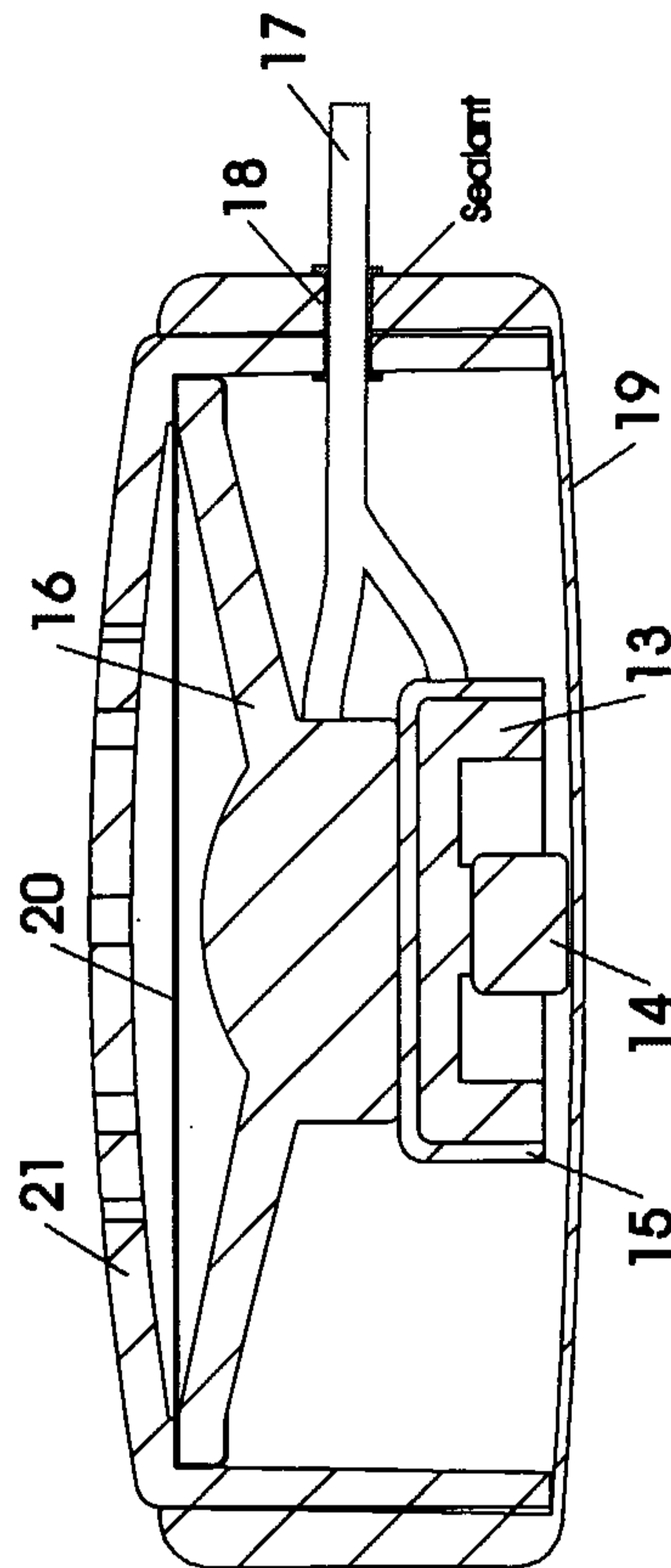

Figure 5A

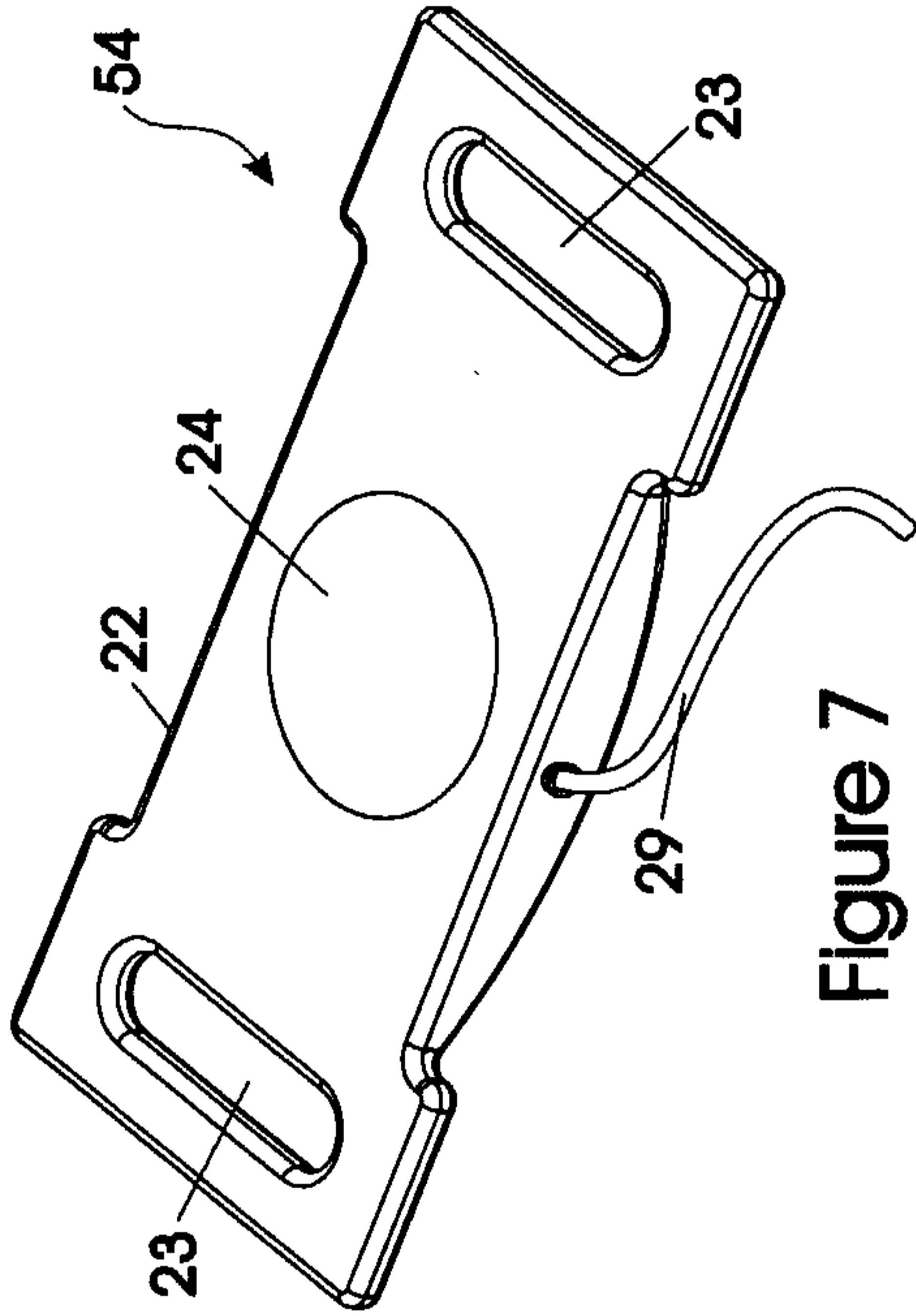

Figure 7

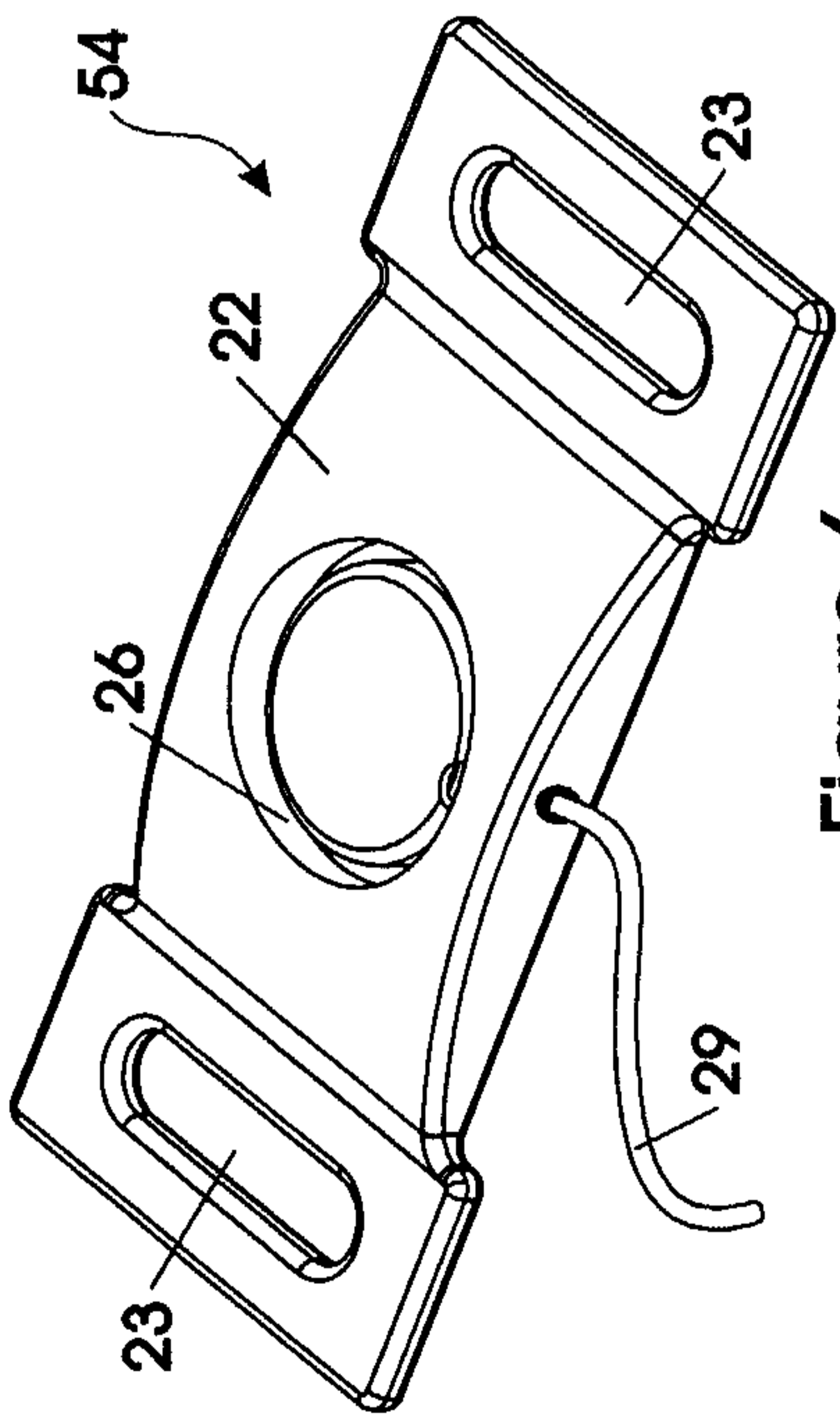

Figure 6

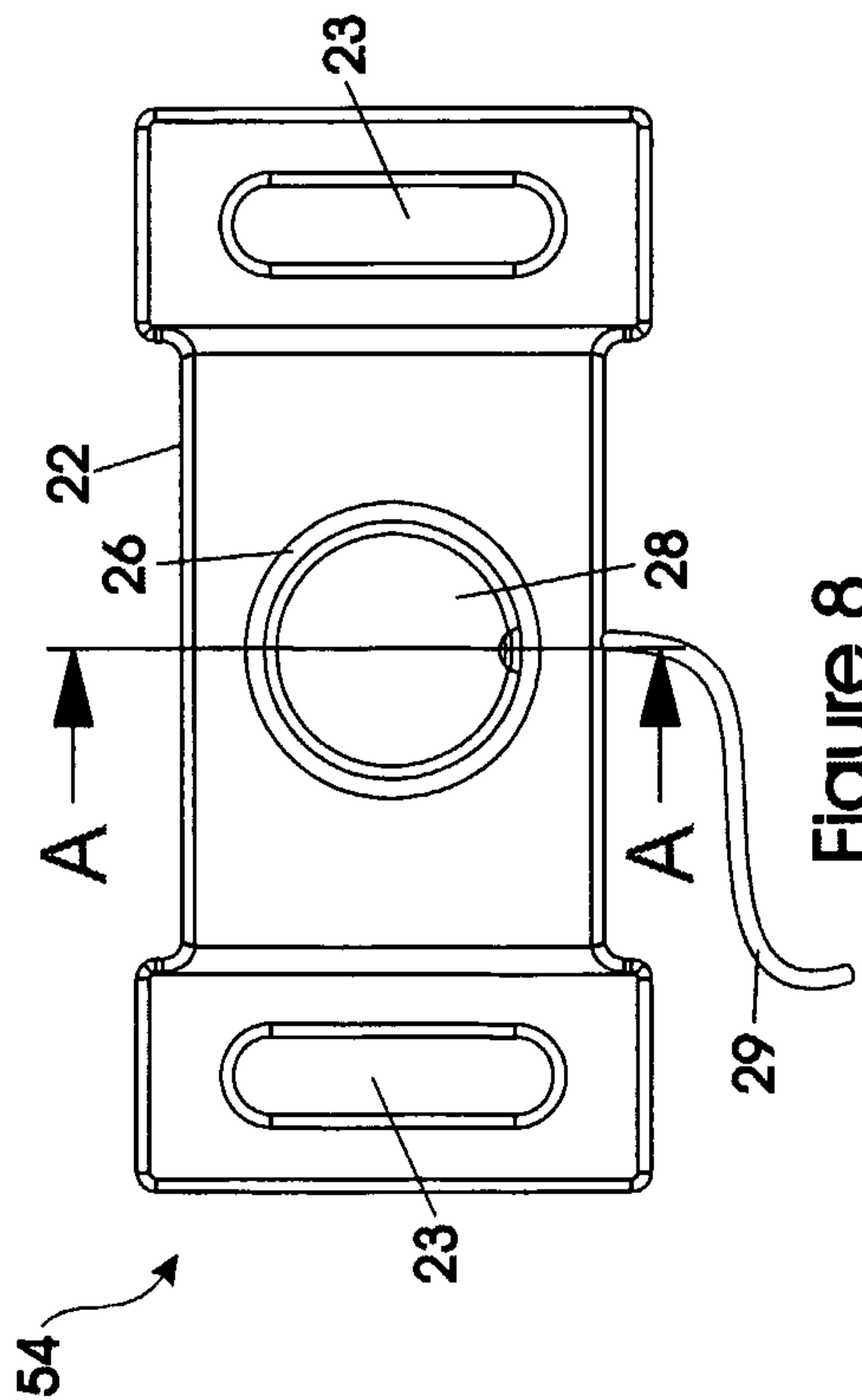

Figure 8

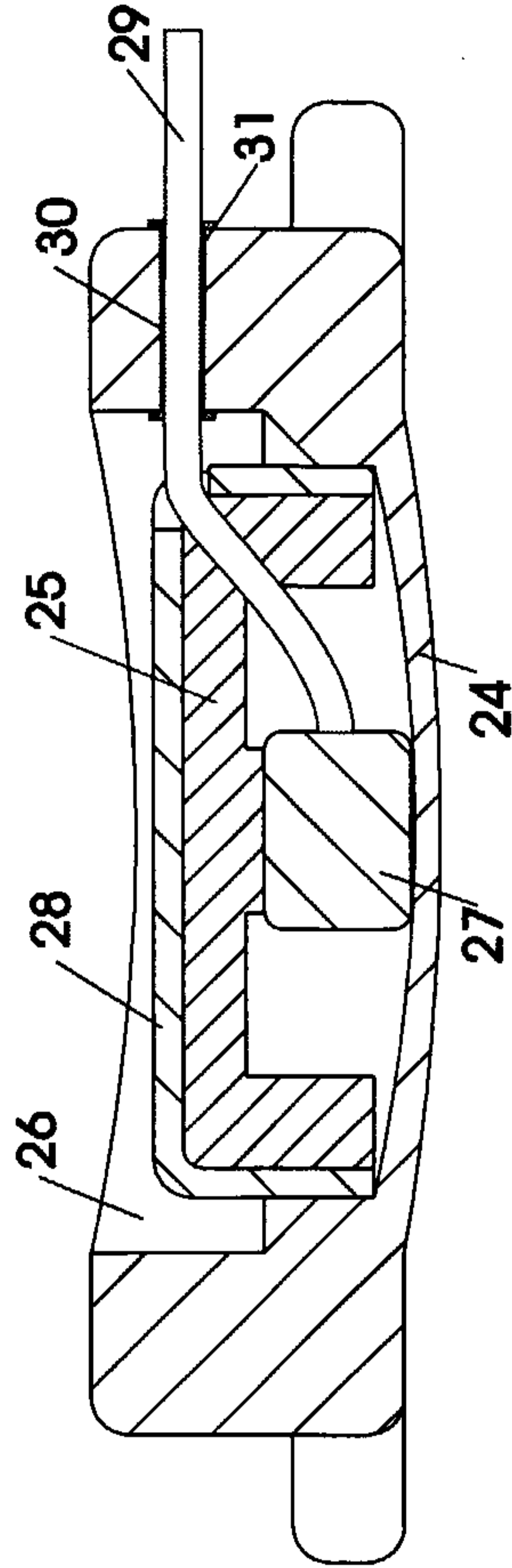

Figure 8A

4/6

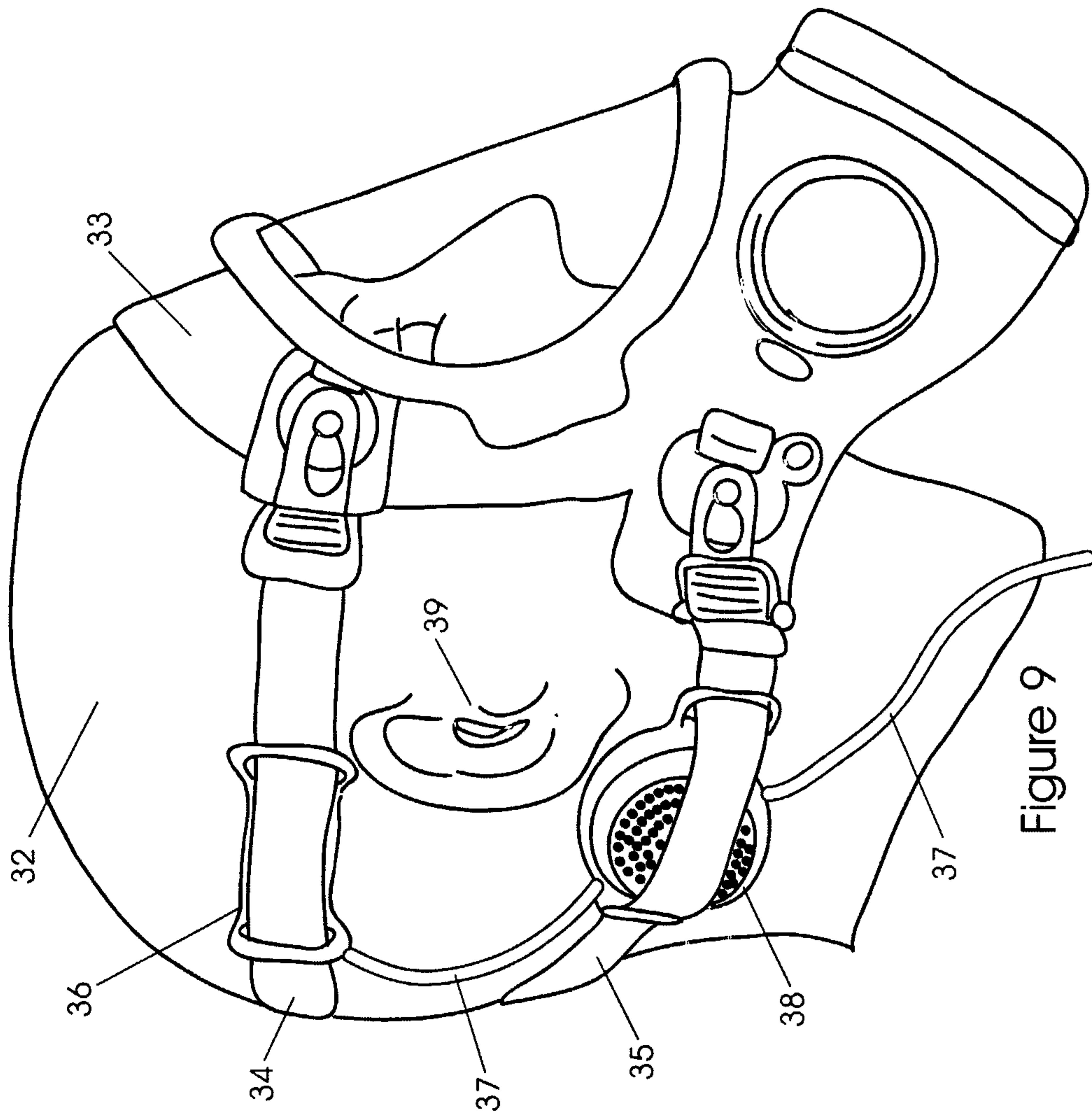

Figure 9

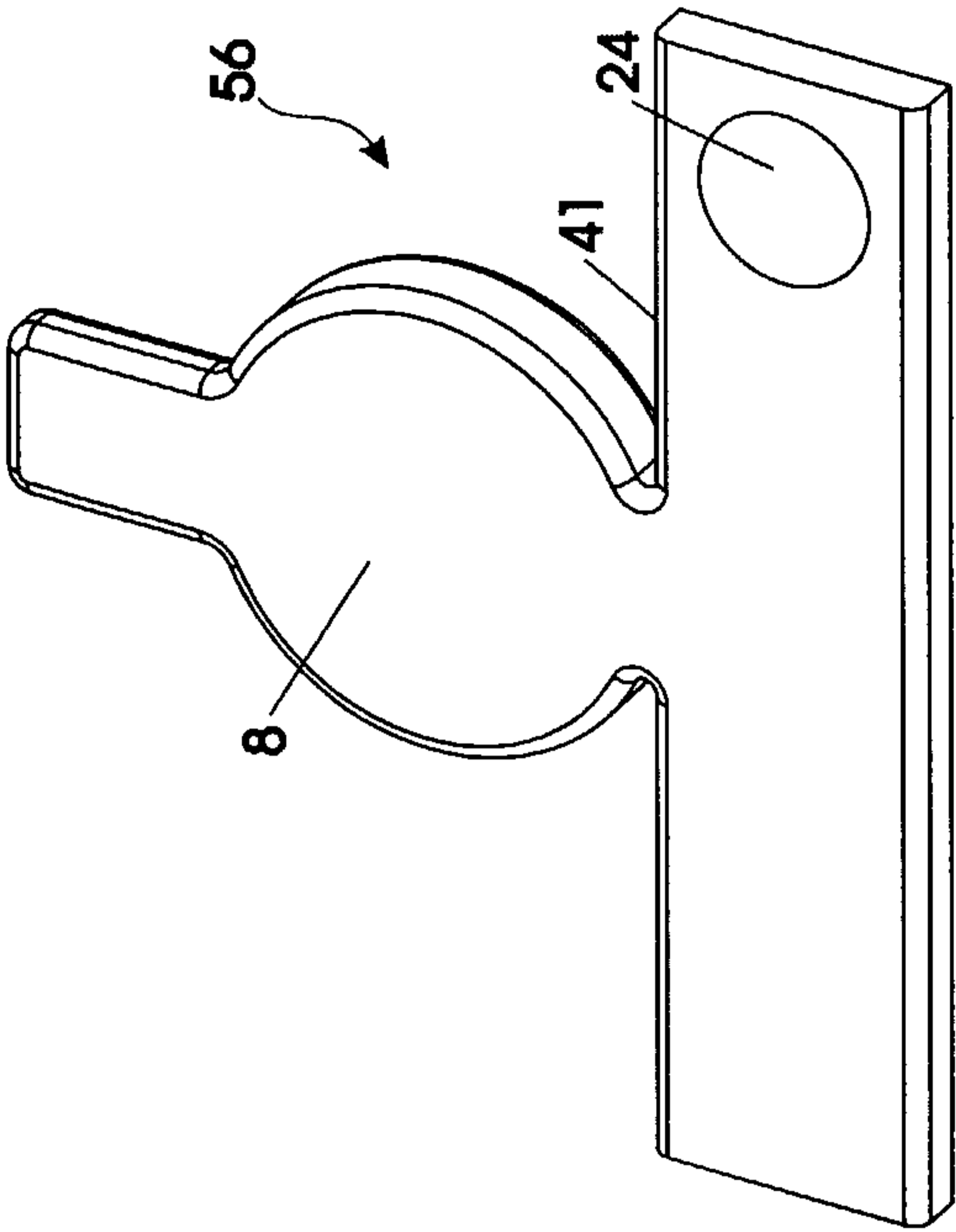

Figure 11

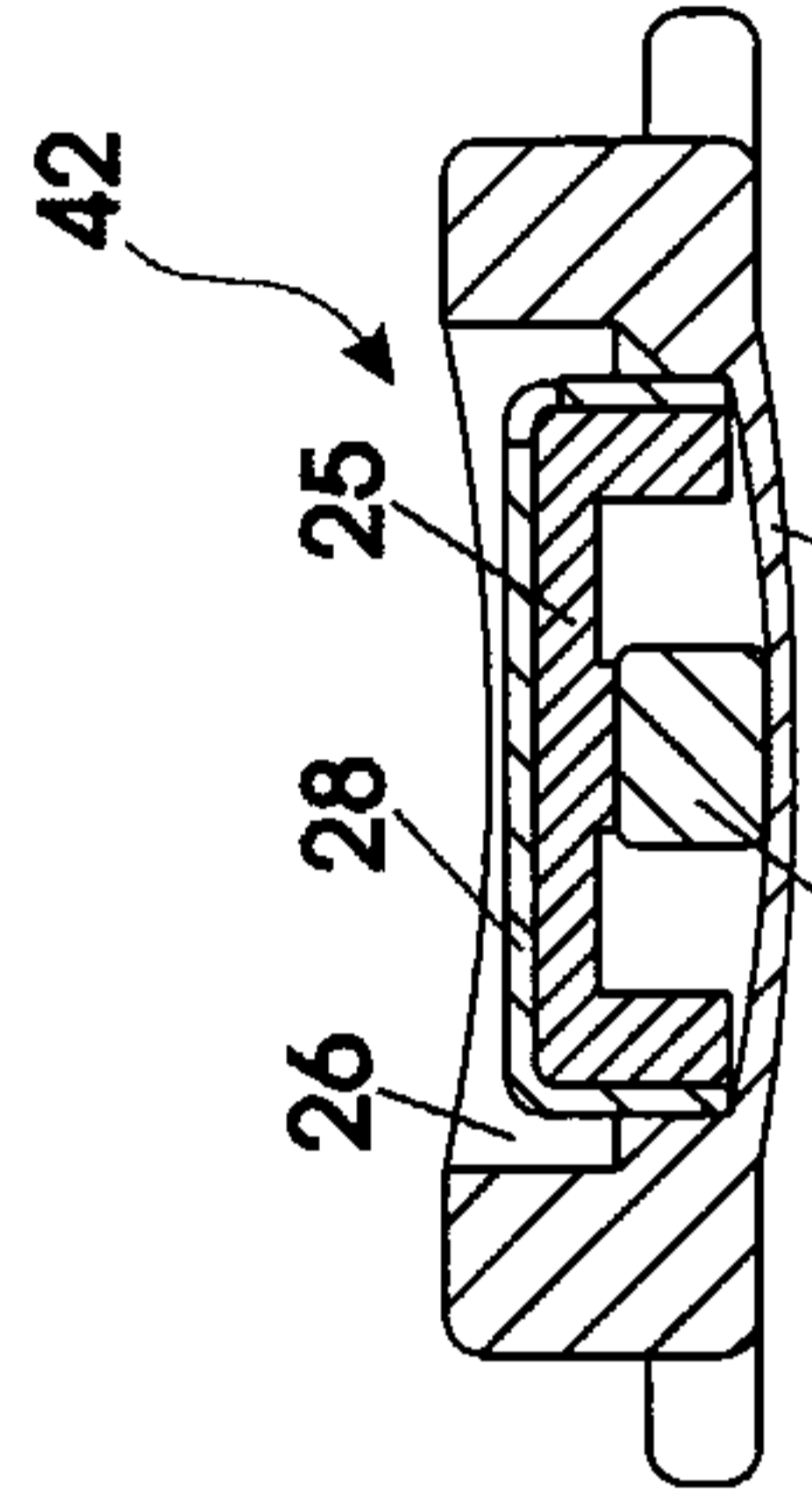

Figure 12B

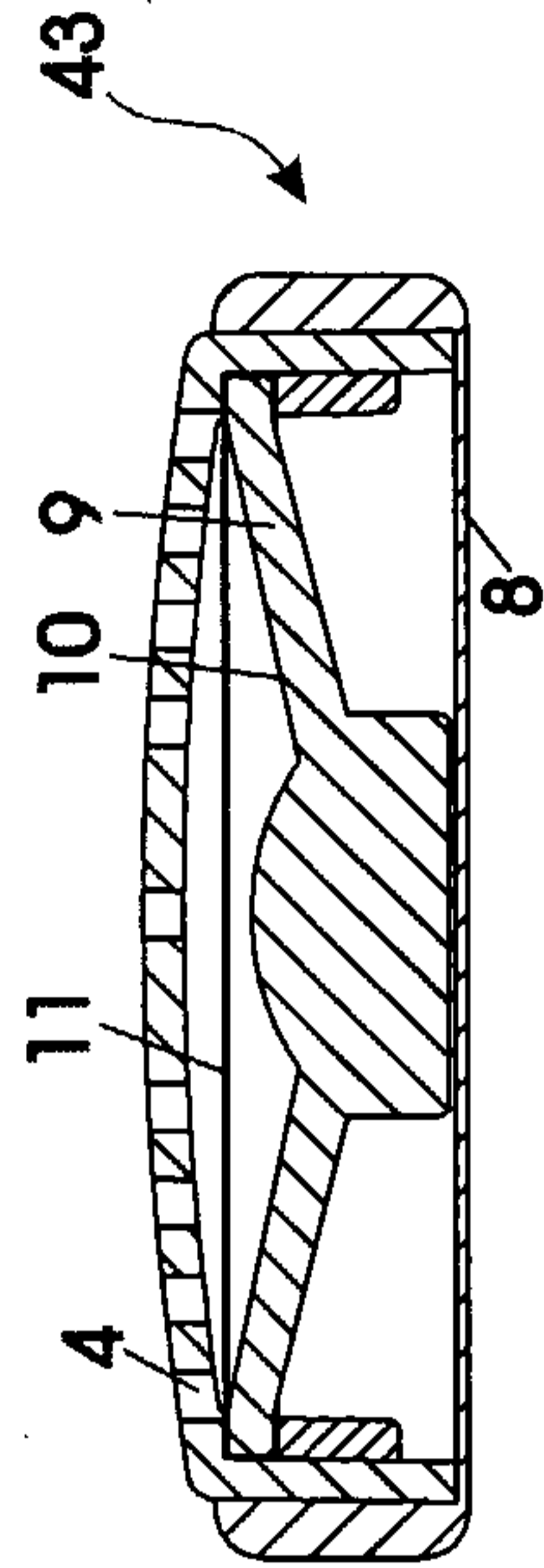

Figure 12A

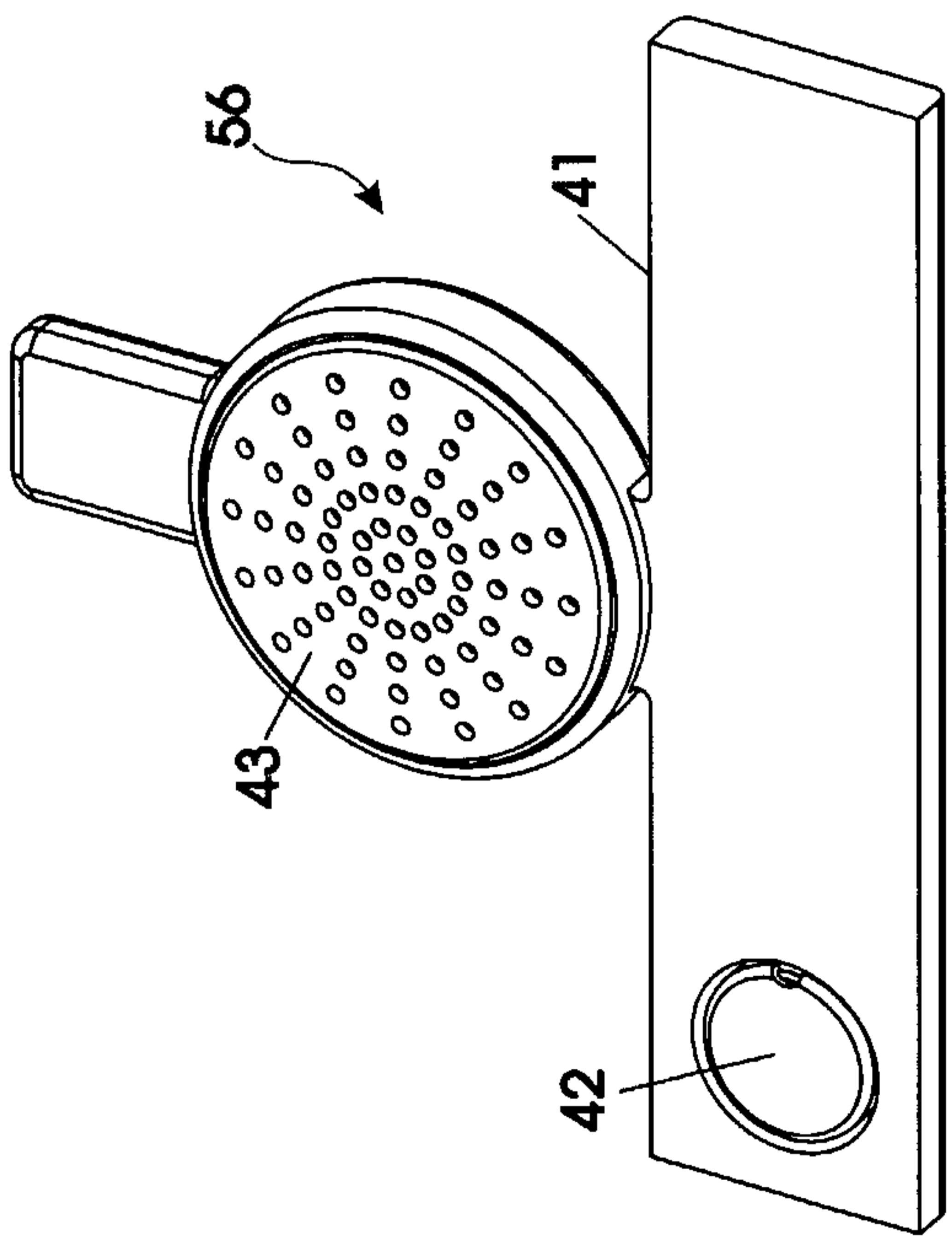

Figure 10

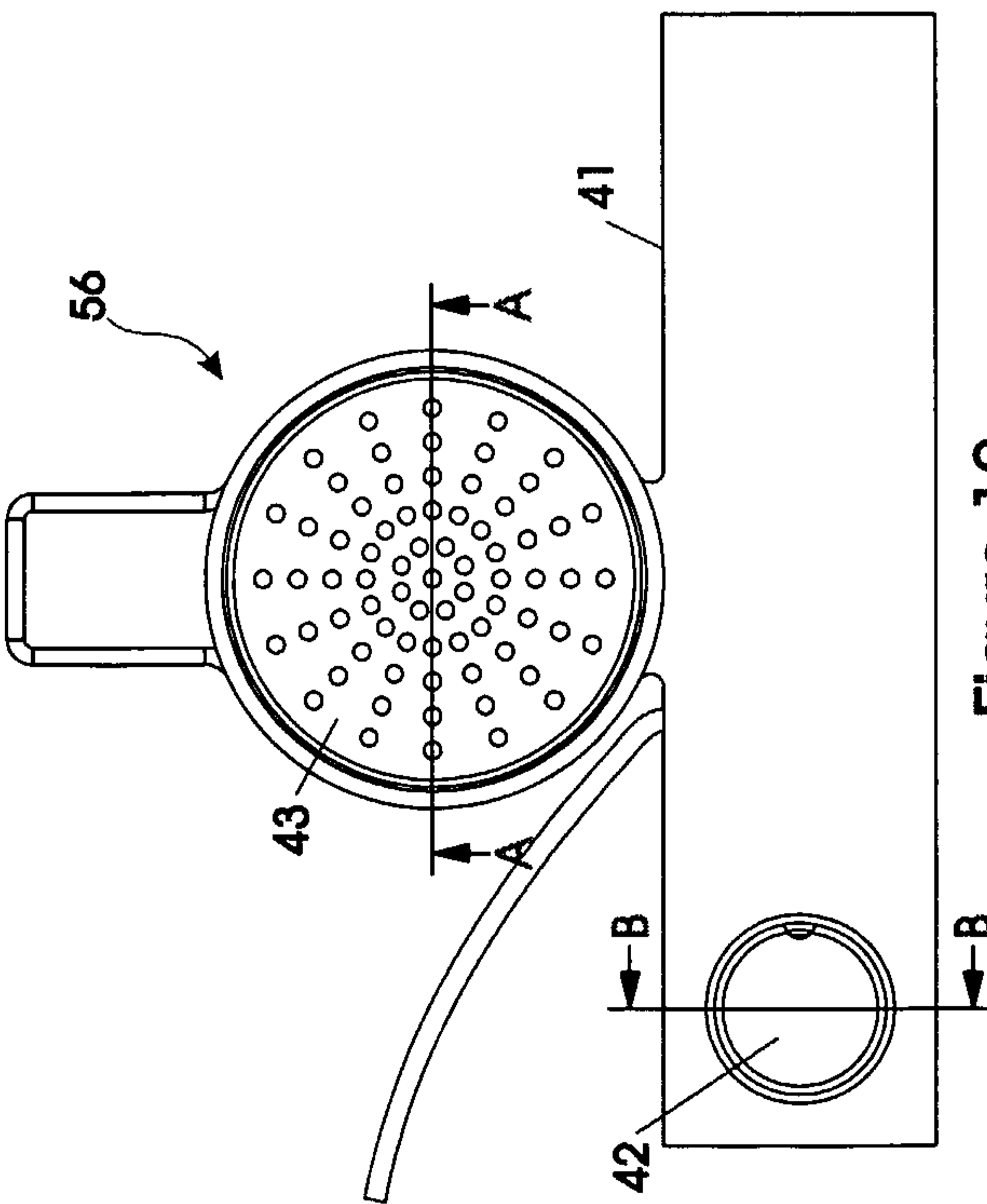

Figure 12

6/6

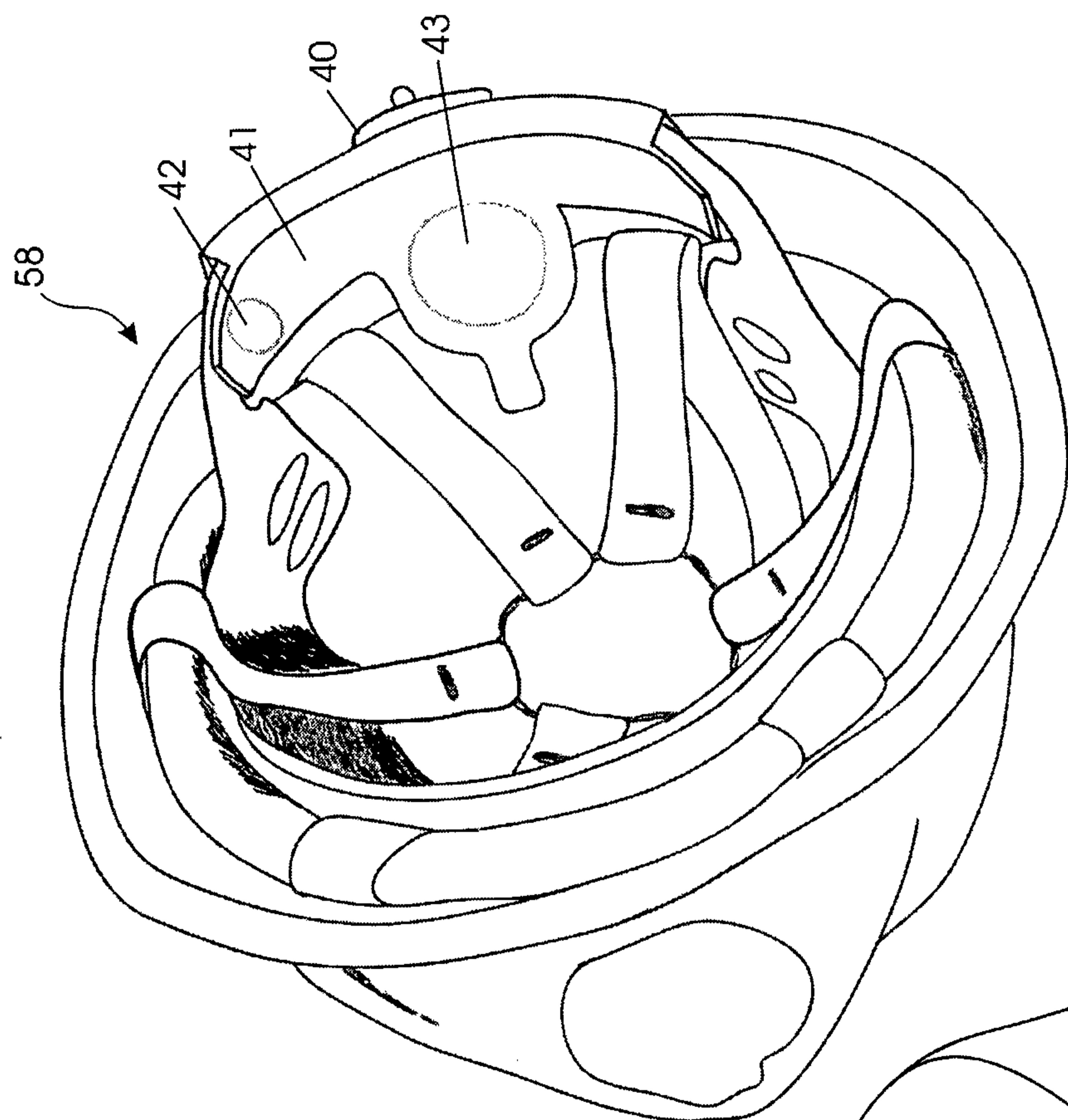

Figure 14

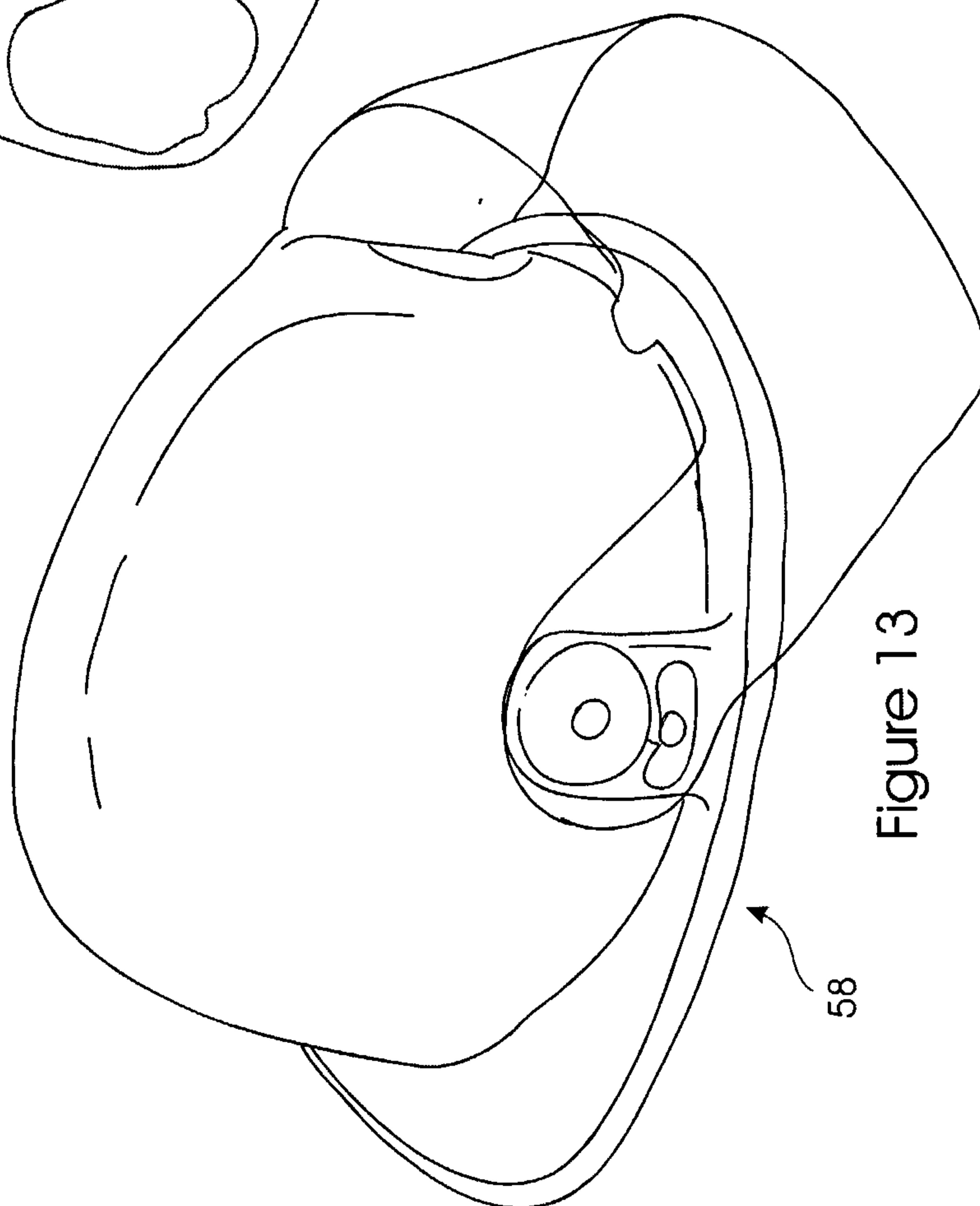

Figure 13

