

ABSTRACT

An attachment arrangement for providing a sensor in a flexible bag, said attachment arrangement comprising:

- a sensor holding part adapted to be integrated with the flexible bag and comprising first locking means protruding out from the flexible bag, said sensor holding part holding an optical sensor inside the flexible bag;
- an adaptor part provided outside the flexible bag and adapted to hold an optical fibre, said adaptor part comprising second locking means adapted to mate with said first locking means to lock the two parts together such that the optical fibre can communicate with the optical sensor inside the bag.

(Fig. 2b)

CLAIMS

1. An attachment arrangement for providing a sensor (13) in a flexible bag (1), said attachment arrangement comprising:

- a sensor holding part (11) adapted to be integrated with the flexible bag (1) and comprising first locking means (17a, b, c, d) protruding out from the flexible bag (1), said sensor holding part (11) holding an optical sensor (13) inside the flexible bag (1);
- an adaptor part (41) provided outside the flexible bag (1) and adapted to hold an optical fibre (7), said adaptor part (41) comprising second locking means (43a, b, c, d) adapted to mate with said first locking means (17a, b, c, d) to lock the two parts together such that the optical fibre (7) can communicate with the optical sensor (13) inside the bag (1).

2. An attachment arrangement according to claim 1, wherein said adaptor part (41) being arranged to be provided to the bag (1) from the bottom of the bag and said adaptor part (41) being arranged to hold the optical fibre (7) along the surface of the bag and the adaptor part (41) comprises a mirror (39) to direct the light from the optical fibre (7) onto the optical sensor (13).

3. An attachment arrangement according to claim 1 or 2, wherein the locking parts (17a, b, c, d, 43a, b, c, d) are designed such that in locking position very small tension stress is provided to the sensor holding part (11).

4. An attachment arrangement according to claim 3, wherein the first locking means (17a, b, c, d) are provided as hooks in a circle around the sensor (13) and are adapted to mate into the second locking means (43a, b, c, d) being tracks comprising guiding surfaces (44, 45) guiding the hooks into a locked position when the adaptor part (41) is rotated in relation to the sensor holding part (11).

5. An attachment arrangement according to any one of the preceding claims, wherein the flexible bag (1) is a bioreactor provided on a support structure (3).

6. An attachment arrangement according to any one of the preceding claims, wherein the sensor holding part (11) comprises:

- a bag attachment part (31) made from a material that can be welded to the flexible bag (1); and
- a sensor attachment part (33) made from a material to which an optical sensor (13) can be attached, wherein the sensor attachment part (33) is forced into an opening (34) in the bag attachment part (31) that is slightly smaller than the sensor attachment part (33) such that the sensor attachment part (33) is kept firmly in place and leakage is minimized.

7. An attachment arrangement according to any one of the preceding claims, wherein the sensor holding part (11) is provided as two parts: one inner sensor holding part (53) and one outer locking part (55), said inner sensor holding part (53) being welded to the inside of the bag (65) and holding the sensor (59) inside the bag and said outer locking part (55) being mated with the inner sensor holding part (53) and welded to the bag (65) from the outside, an inner bag support ring (61) and an outer bag support ring (63) being provided from each side of the bag (65) in order to keep the inner sensor holding part (53) and the outer locking part together (55), said outer locking part (55) further comprising said protruding first locking means (17a, b, c, d) to be connected to the second locking means (43a, b, c, d) of the adaptor part (41).

8. A flexible bag comprising a sensor holding part (11) integrated with the flexible bag, said sensor holding part (11) holds an optical sensor (13) inside the flexible bag and comprises first locking means (17a, b, c, d) protruding out from the flexible bag, said sensor holding part (11) being adapted to be mated with an adaptor part (41) provided outside the flexible bag, said adaptor part (41) holding an optical fibre (7) and comprising second locking means (43a, b, c, d) adapted to mate with said first locking means (17a, b, c, d) to lock the two parts together such that the optical fibre (7) can communicate with the optical sensor (13) inside the bag.

9. A flexible bag according to claim 8, wherein the sensor holding part (11) is integrated with the flexible bag in the bottom of the bag.

10. A flexible bag according to claim 8 or 9, wherein the locking parts (17a, b, c, d, 43a, b, c, d) are designed such that in locking position very small tension stress is provided to the sensor holding part (11).

11. A flexible bag according to any one of the claims 8-10, wherein the first locking means (17a, b, c, d) are provided as hooks in a circle around the sensor (13) and are adapted to mate into the second locking means (43a, b, c, d) being tracks comprising guiding surfaces (44, 45) guiding the hooks into a locked position when the adaptor part (41) is rotated in relation to the sensor holding part (11).

12. A flexible bag according to any one of the claims 8-11, wherein the flexible bag (1) is a bioreactor provided on a support structure (3).

13. A flexible bag according to any one of the claims 8-12, wherein the sensor holding part (11) comprises:

- a bag attachment part (31) made from a material that can be welded to the flexible bag;
- and
- a sensor attachment part (33) made from a material to which an optical sensor (13) can be attached, wherein the sensor attachment part (33) is forced into an opening (34) in the bag attachment part (31) that is slightly smaller than the sensor attachment part (33) such that the sensor attachment part is kept firmly in place and leakage is minimized.

14. A flexible bag according to any one of the claims 8-13, wherein the sensor holding part (11) is provided as two parts: one inner sensor holding part (53) and one outer locking part (55), said inner sensor holding part (53) being welded to the inside of the bag and holding the sensor (59) inside the bag and said outer locking part (55) being mated with the inner sensor holding part (53) and welded to the bag from the outside, an

inner bag support ring (61) and an outer bag support ring (63) being provided from each side of the bag in order to keep the inner sensor holding part (53) and the outer locking part together (55), said outer locking part (55) further comprising said protruding first locking means (17a, b, c, d) to be connected to the second locking means (43, a, b, c, d) of the adaptor part (41).

15. An adaptor part (41) adapted to hold an optical fibre (7), said adaptor part (41) comprising second locking means (43a, b, c, d) adapted to mate with first locking means (17a, b, c, d) of a sensor holding part (11) integrated with a flexible bag (1) said first locking means (17a, b, c, d) protruding out from the flexible bag, said sensor holding part (11) holding an optical sensor (13) inside the flexible bag, said first and second locking means are adapted to be mated such that the two parts are locked together such that the optical fibre (7) can communicate with the optical sensor (13) inside the bag.

16. An adaptor part according to claim 15, wherein said adaptor part (41) being arranged to be provided to the bag (1) from the bottom of the bag and said adaptor part (41) being arranged to hold the optical fibre (7) along the surface of the bag and the adaptor part comprises a mirror (39) to direct the light from the optical fibre (7) onto the optical sensor (13).

17. An adaptor part according to claim 15 or 16, wherein the locking parts (17a, b, c, d, 43a, b, c, d) are designed such that in locking position very small tension stress is provided to the sensor holding part and the risk for creeping is minimized.

18. A adaptor part according to any one of the claims 15-17, wherein the second locking means (43a, b, c, d) being tracks comprising guiding surfaces (44, 45) guiding the first locking means (17a, b, c, d) in the form of hooks into a locked position when the adaptor part (41) is rotated in relation to the sensor holding part (11).

Dated this 1/06/2012

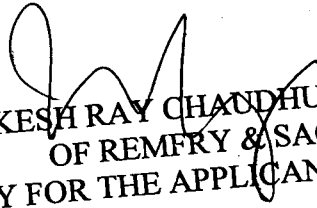
[HRISHIKESH RAY CHAUDHURY]
OF REMFRY & SAGAR
ATTORNEY FOR THE APPLICANT[S]

1/10

ORIGINAL

0-1 JUN 2012

4839 DELWP 12

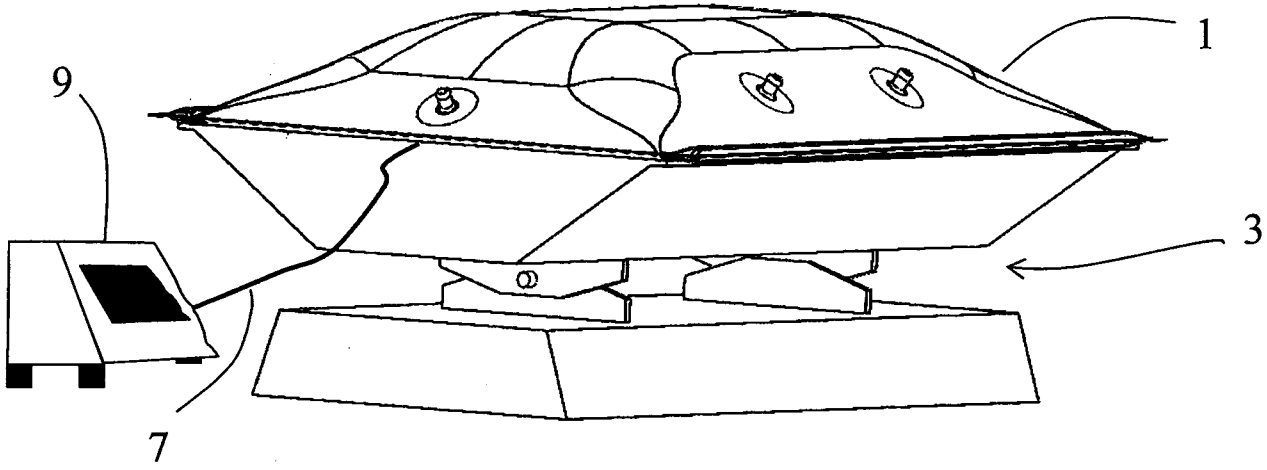

Fig. 1a

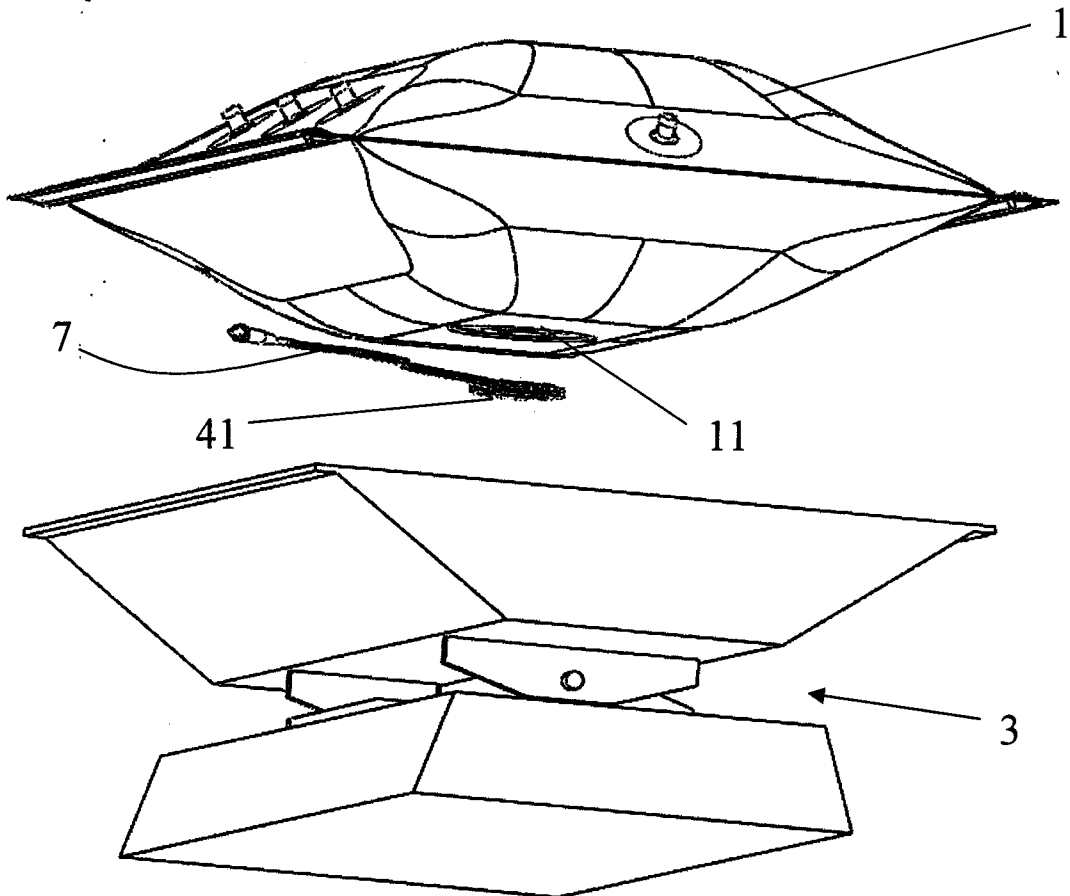



Fig. 1b

(HRISHIKESH RAY CHAUDHURY)
OF REMFRY & SAGAR
ATTORNEY FOR THE APPLICANT[S]

01 JUN 2012
4 3 9 DELNP 12

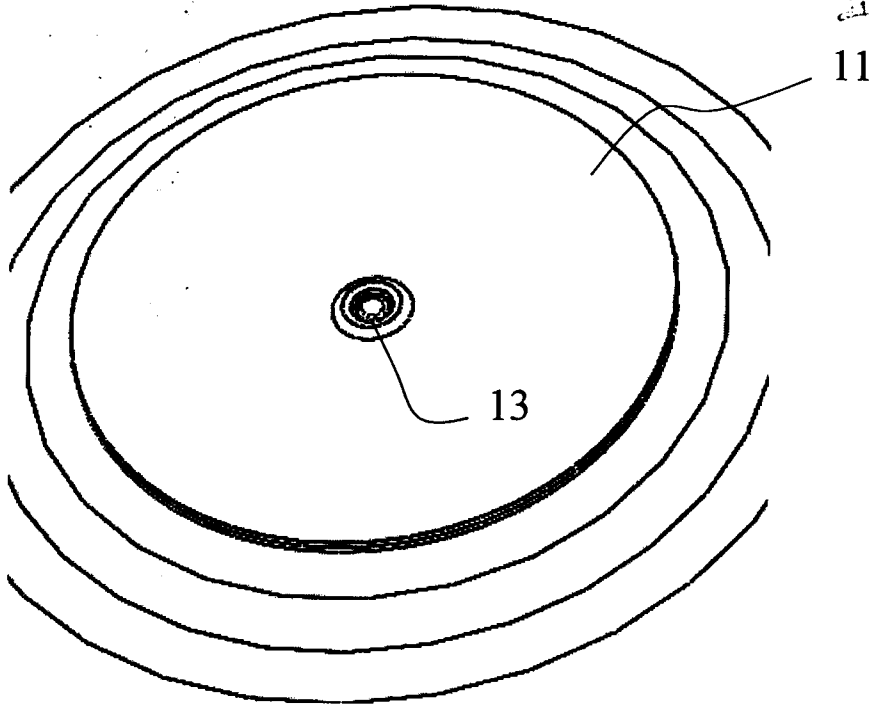

Fig. 2a

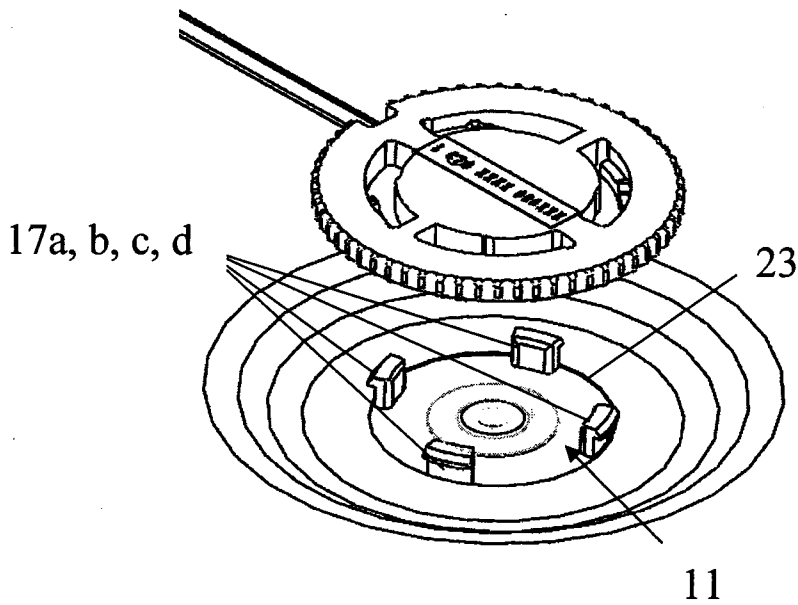

Fig. 2b

(HRISHIKESH RAY CHAUDHURY)
OF REMFRY & SAGAR
ATTORNEY FOR THE APPLICANT[S]

ORIGINAL 1 JUN 2012

4339 DELNP 12

3/10

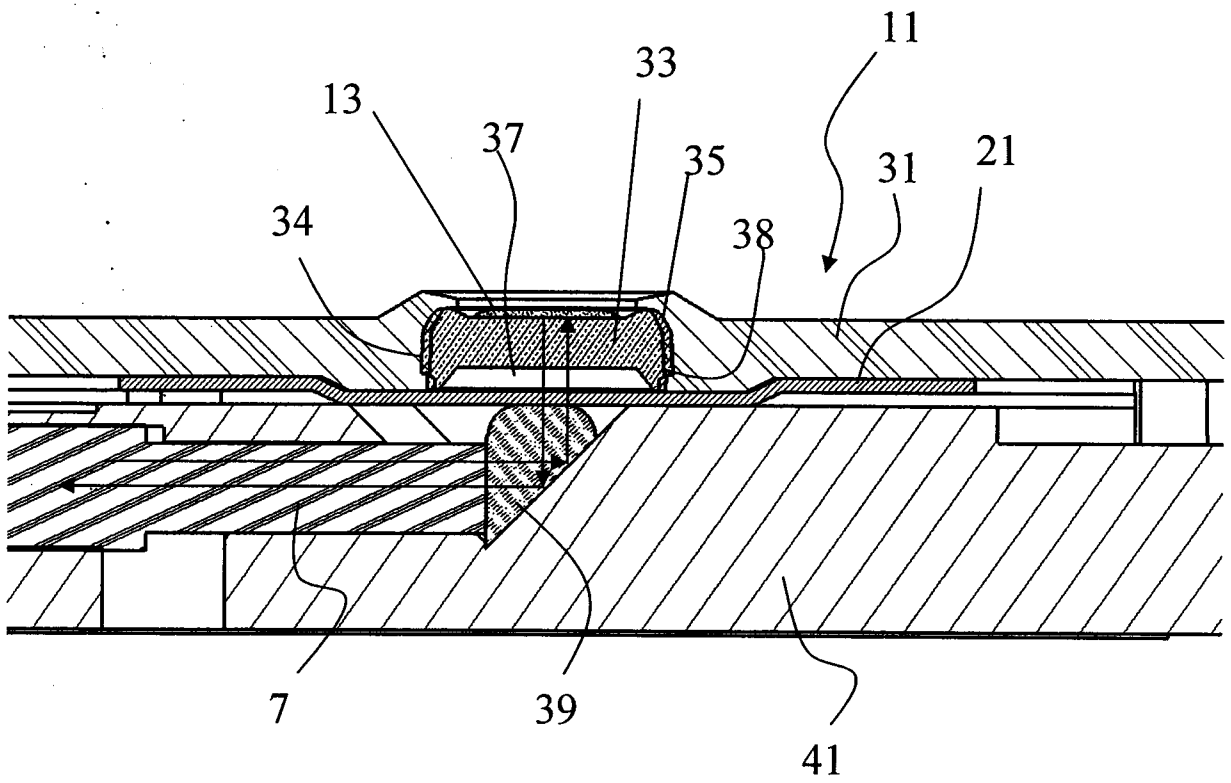
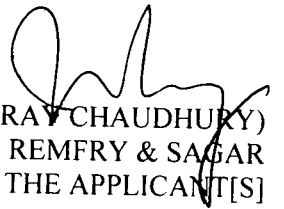

Fig. 3

(HRISHIKESH RAY CHAUDHURY)
OF REMFRY & SAGAR
ATTORNEY FOR THE APPLICANT[S]

ORIGINAL 01 JUN 2012

4/10

4839 DELNP 12

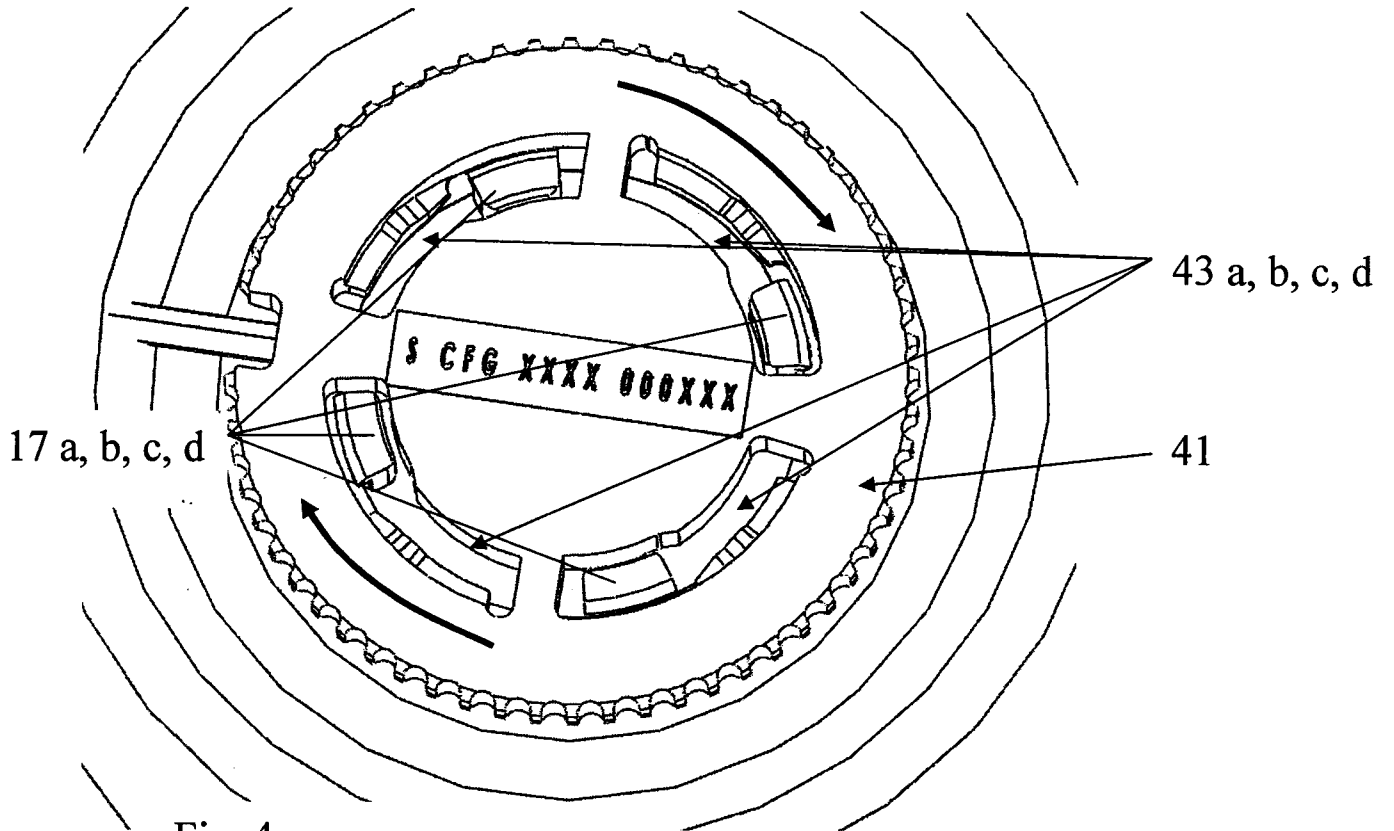

Fig. 4a

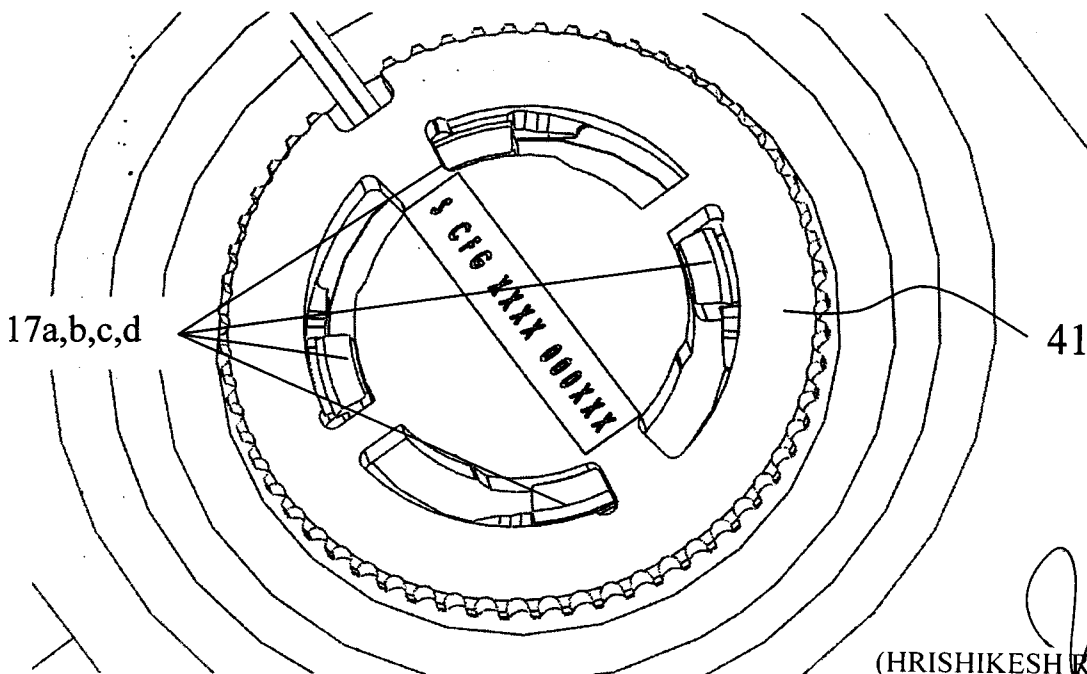

Fig. 4b

(HRISHIKESH RAY CHAUDHURY)
OF REMFRY & SAGAR
ATTORNEY FOR THE APPLICANT[S]

0-1 JUN 2012
4839 JUN 12

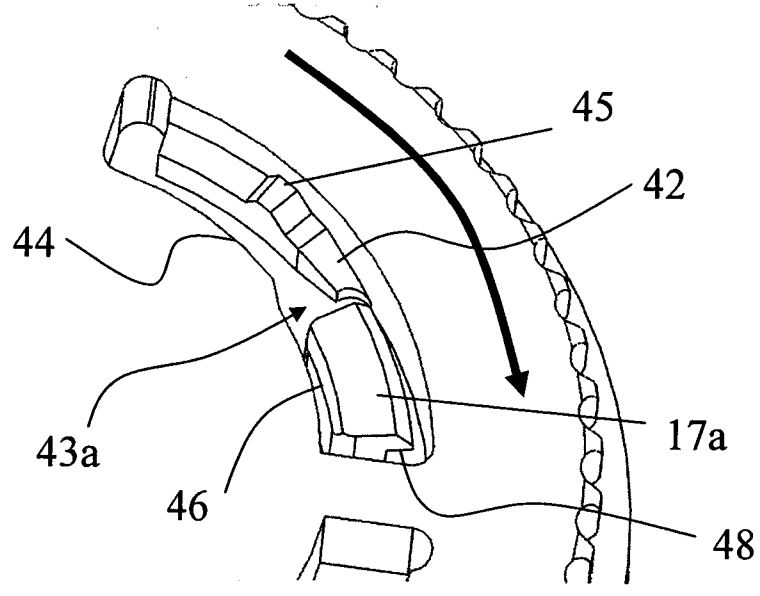

Fig. 5a

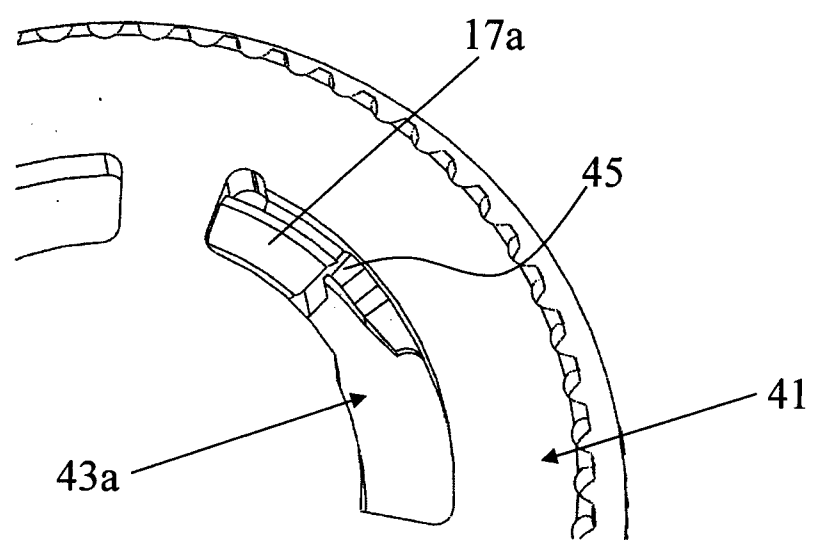
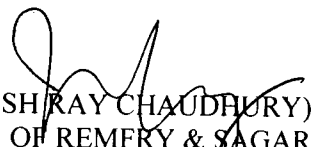

Fig. 5b

(HRISHIKESH RAY CHAUDHURY)
OF REMFRY & SAGAR
ATTORNEY FOR THE APPLICANT[S]

ORIGINAL

6/10

0-1 JUN 2012
4839
12

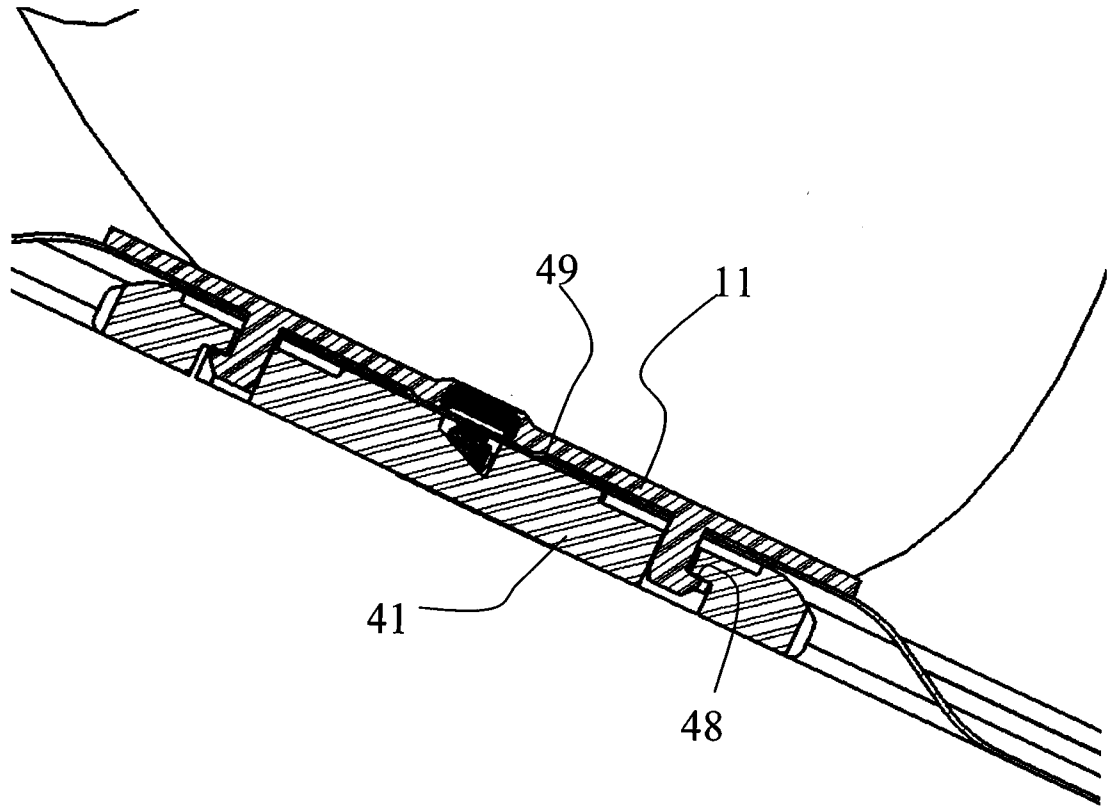



Fig. 6

(HRISHIKESH RAY CHAUDHURY)
OF REMFRY & SAGAR
ATTORNEY FOR THE APPLICANT[S]

PRIOR ART

01 JUN 2012

4839 DELHP 12

7/10

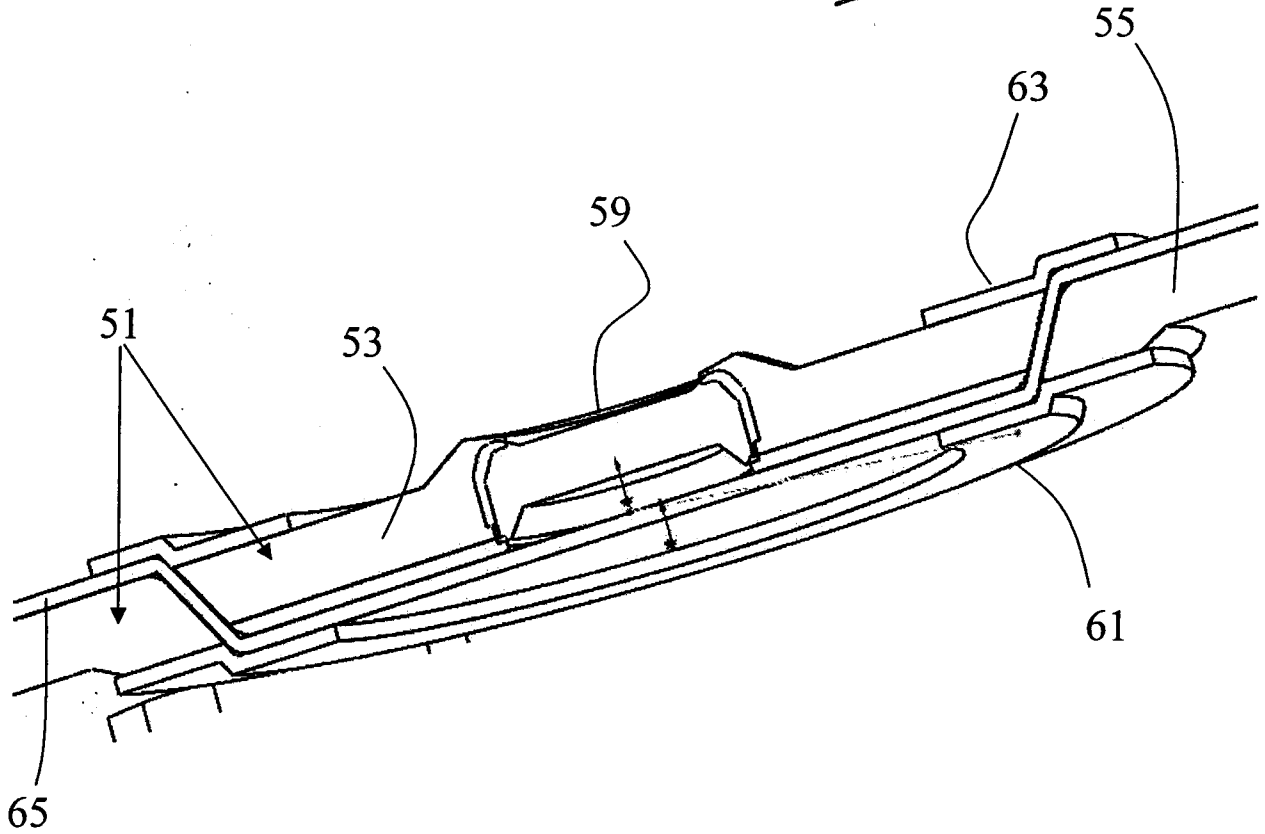
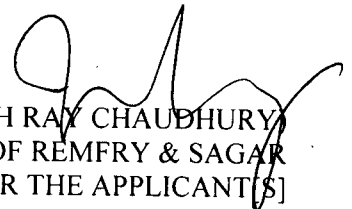

Fig. 7a

(HRISHIKESH RAY CHAUDHURY)
OF REMFRY & SAGAR
ATTORNEY FOR THE APPLICANT(S)

8/10

GRANTED 01 JUN 2012

4839 DELNP 12

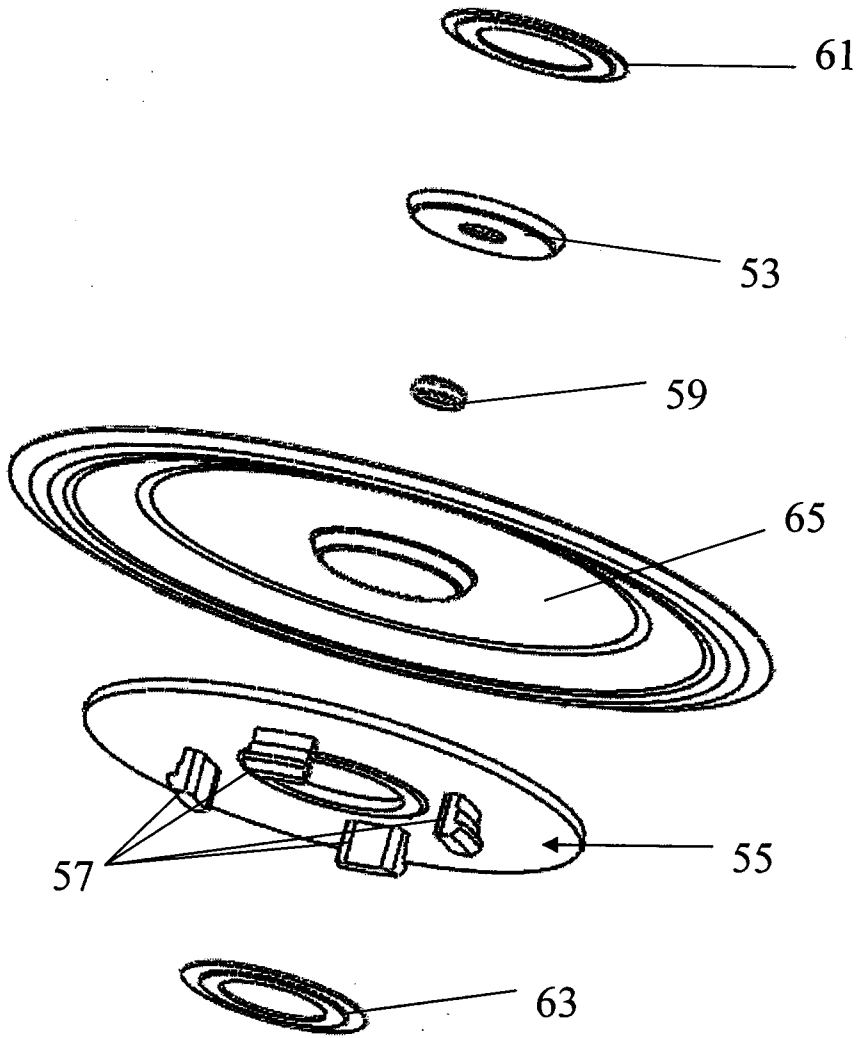



Fig. 7b

(HRISHIKESH RAY CHAUDHURY)
OF REMFRY & SAGAR
ATTORNEY FOR THE APPLICANT[S]

ORIGINAL

SHEET 9 OF 10

9/10

4839
01 JUN 2012

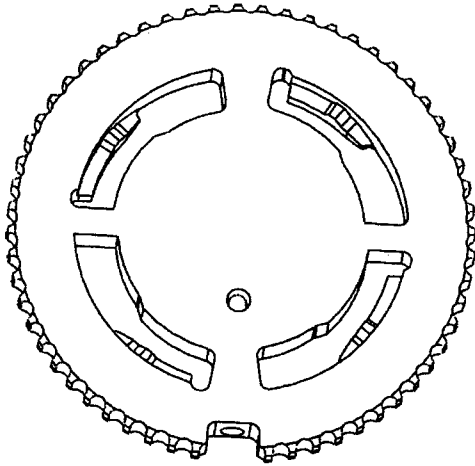

Fig. 8a

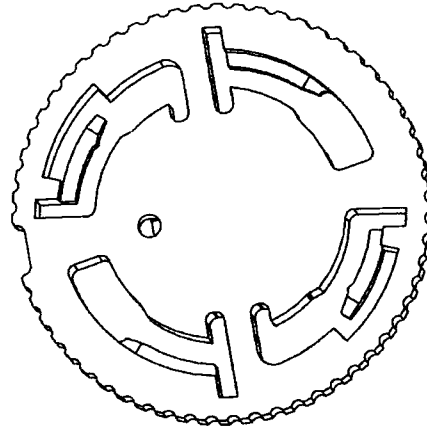

Fig. 8b

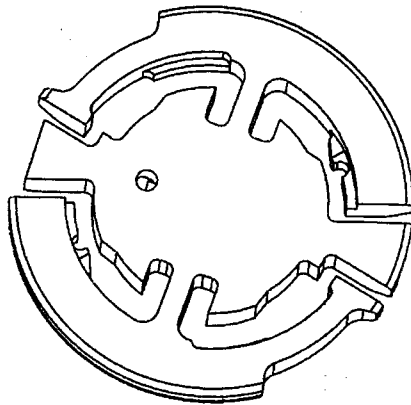

Fig. 8c

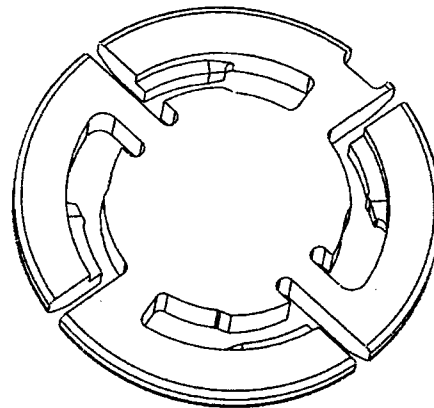
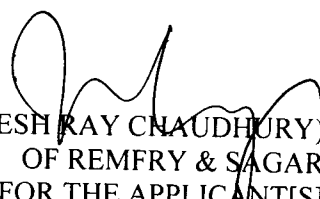

Fig. 8d

(HRISHIKESH RAY CHAUDHURY)
OF REMFRY & SAGAR
ATTORNEY FOR THE APPLICANT[S]

ORIGINAL

10/10

4839 DELP 12
01 JUN 2012

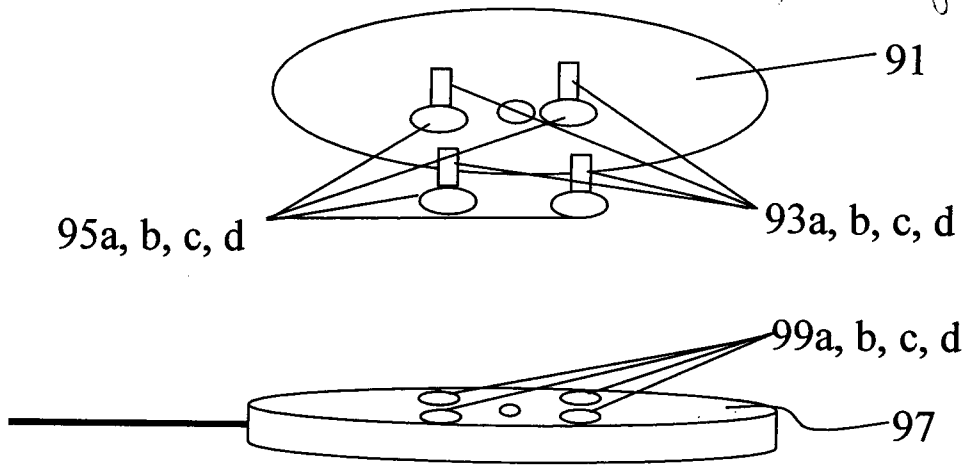

Fig. 9a

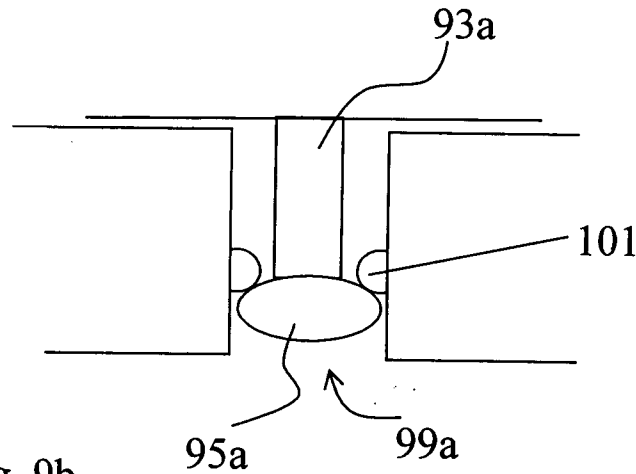



Fig. 9b

(HRISHIKESH RAY CHAUDHURY)
OF REMFRY & SAGAR
ATTORNEY FOR THE APPLICANT[S]

SENSOR ATTACHMENT ARRANGEMENT FOR FLEXIBLE BAGS

TECHNICAL FIELD OF THE INVENTION

The present invention relates to an attachment arrangement for providing a sensor in a flexible bag. It also relates to a flexible bag comprising a sensor holding part and to an adaptor part adapted to mate with said sensor holding part in the bag.

BACKGROUND OF THE INVENTION

Bioreactors are used in the bioprocess industry for growing cells, e.g. for the purpose of producing biopharmaceuticals. Disposable bioreactors have been used more and more and are an increasing trend in the industry. These disposable bioreactors are flexible bags made of plastic, for example welded polyethylene film. For the culturing of cells it is important to measure some features of the culture inside the bioreactor. The features could be for example temperature, pH, and dissolved oxygen (DO) etc. In flexible bags it is common to provide sensors from the upper side of the bag, like the *Cellbag™ 50L/pH* from GE Healthcare. One disadvantage with this is the risk of the sensor not being inside the culture all the time. Optical sensors for measuring for example pH and DO are provided from for example PreSens. Such an optical sensor, sometimes called a sensor spot, is a spot of a dye material typically comprising two different fluorescent materials. When the sensor spot is illuminated, fluorescent substances of the spot will emit light. Using suitable fluorescent substances this emitted light can be indicative of a property of the culture, such as pH or DO. Thus the returned light can be analysed and for example pH or DO can be determined. For optimal performance, these sensors should be provided in the culture all the time. Providing the sensors in the bottom part of the bag is often not as convenient as providing the sensor from the upper side due to the support structure often provided under the bag. Furthermore these optical sensors typically can not be attached directly on the material of the bag due to chemical incompatibility. Another issue is that the sensor assembly should be as flat as possible to ensure that it always will remain under the liquid surface.

SUMMARY

It is an object of the present invention to provide an attachment arrangement for attaching an optical sensor to a flexible bag that solves the problems of prior art described above.

This is achieved in an attachment arrangement according to claim 1, in a flexible bag according to claim 8 and in an adaptor part according to claim 15.

Suitable embodiments are described in the dependent claims and in the detailed description below.

BRIEF DESCRIPTION OF THE DRAWINGS

Figure 1a is a schematic view of a bioreactor in a rocking support structure provided with an optical sensor according to the invention.

Figure 1b is an exploded view of the system shown in Figure 1a.

Figure 2a shows a sensor holding part according to one embodiment of the invention from one side.

Figure 2b shows the sensor holding part of Figure 2a from the other side.

Figure 3 is a cross section of the sensor attaching arrangement according to one embodiment of the invention.

Figure 4a shows an adaptor part according to one embodiment of the invention in a non locked position.

Figure 4b shows the adaptor part of Figure 4a in a locked position.

Figure 5a is a closer view of the locking mechanism in one embodiment of the invention before locking.

Figure 5b is the same view as Figure 5a but in locked position, i.e. the adaptor part has been turned to a locked position.

Figure 6 is a cross section view showing the sensor holding part being locked in the adaptor part according to one embodiment of the invention.

Figure 7a shows another embodiment of the sensor holding part where the sensor holding part is separated into an inner sensor holding part and an outer sensor holding part.

Figure 7b is an exploded view of the inner and outer sensor holding parts of Figure 7a.

Figures 8a-8c shows three different embodiments of adaptor parts according to the invention.

Figures 9a and 9b show schematically a sensor holding part and an adaptor part according to another embodiment of the invention.

DETAILED DESCRIPTION OF THE EMBODIMENTS

Figure 1a is a schematic view of a bioreactor 1 in a rocking support structure 3. Figure 1b shows the same bioreactor system but in an exploded view. In the bottom part of the bioreactor 1 a sensor holding part 11 is provided according to the invention. The sensor holding part holds an optical sensor on the inside of the bag. Details of this will be described further down in the description. An optical fibre 7 is provided to a position close to the position of the optical sensor but outside the bag with the help of an adaptor part 41 (described in detail below). A monitor 9 is also shown where the readings from the optical sensor can be monitored.

According to the invention a sensor holding part is provided inside the bag. The sensor holding part is integrated with the bag by means of for example welding. An adaptor part holding the optical fibre is provided outside the bag. The sensor holding part comprises an optical sensor and according to the invention first locking parts protruding out from the bag. These first locking parts are adapted to mate with second locking parts of the adaptor part such that the optical fibre in the adaptor part will be safely positioned to and can communicate with the sensor inside the bag. Suitably the locking parts provide a locking mechanism that holds the optical fibre in a stable position in relation to the sensor in all directions. Suitably the optical fibre is provided lying flat along the bottom of the bag, i.e. the optical fibre is not pointing towards the sensor in the bag. Instead a mirror is provided in the adaptor part such that the light can be directed to the sensor when the adaptor part is positioned below the sensor. This is suitable because the support structure does not need to be adapted to the sensor attachment arrangement. Hereby this sensor attachment arrangement can be used on already existing systems without any adaptation. Furthermore, since no part of the sensor attachment arrangement is secured to the support structure, the bag can be freely moved together with the sensor and the sensor attachment arrangement. More description around the details of suitable embodiments of the invention are given below.

Figure 2a is a view of a sensor holding part 11 according to one embodiment of the invention. The sensor holding part 11 is in one embodiment positioned inside the bag and secured to the inner bag surface for example by means of welding. In another embodiment the sensor holding part is welded to the outside of the bag surface and a hole is provided in the bag surface around the sensor. In Figure 2a the side adapted to face the interior of the bag is shown. In this embodiment the sensor holding part 11 is circular. This is suitable because a circular shape will give rise to less tension in the joint between the bag and the sensor holding part than would a shape with sharp edges. Furthermore, tension stress can cause creeping deformation of the sensor holding part. The circular geometry also reduces the risk for dimension changes due to different shrinkage in the molding process. However other geometries of the sensor holding part would also be possible. In the centre of the sensor holding part 11 the optical sensor 13,

is provided. The optical sensor is a dye as described in the background chapter and can also be called a sensor spot. The sensor holding part should be provided in a material that can be welded to the bag material. The bag is often made from polyethylene and in this embodiment also the sensor holding part is made from polyethylene. However, the material of the sensor 13 can not be attached directly to polyethylene and therefore the sensor has been provided on a small piece of another material to which the sensor can be attached and which is transparent. In this embodiment polycarbonate has been used. This is described in more detail below in relation to Figure 3.

Figure 2b shows the sensor holding part 11 of Figure 2a from the other side, i.e. from the side pointing out from the bag. In this embodiment four first locking means in the form of hooks 17a, 17b, 17c, 17d are provided protruding out from the sensor holding part. The hooks are provided on the circumference of a circle. The number of the hooks can also be 2, 3, 5 or even more. The first locking means 17a, b, c, d are adapted to protrude out from the bag when the sensor holding part is positioned inside the bag. At least one hole needs to be provided in the bag surface to let the first locking means 17 a, b, c, d through. In one embodiment a circular hole 23 as large as comprising all the first locking means 17a, b, c, d is provided in the bag. The sensor holding part is welded to the bag in order to prevent any leakage. In another embodiment the same circular hole is provided in the bag and furthermore a smaller circular piece of bag film is welded over the central part of the sensor holding part but inside the first locking means 17 a, b, c, d. This smaller circular piece of bag film will hereby cover the sensor in the middle of the sensor holding part. This could be suitable if there is any risk of leakage through the sensor attaching arrangement. This is described in more detail below in relation to Figure 3. In another embodiment it would also be possible to provide one separate hole in the bag for each first locking means, i.e. in this embodiment four holes would be provided. The sensor holding part needs then to be welded to the bag around all these four holes in order to prevent any leakage. Alternatively, the bag surface could be welded to the sensor holding part in one circle on the inside of the locking means and one circle outside the locking means.

Figure 3 is a cross section of a central part of the sensor attachment arrangement according to one embodiment of the invention. In this embodiment the sensor holding part 11 comprises two parts. One bag attachment part 31 adapted to be welded to the bag and one sensor attachment part 33 where the sensor 13 is provided. The sensor attachment part 33 is made of a material to which the sensor 31 can be attached. This could be for example polycarbonate. The sensor attachment part 33 is pressed fit into an opening 34 in the bag attachment part 31. The bag attachment part 31 is made from a material that can be welded to the bag. Many bags are made from polyethylene and in this example also the bag attachment part 31 is made from polyethylene. The reason why the sensor 13 is not attached directly to the bag attachment part 31 is that the sensor 13 used in this example can not be attached to a material that also can be welded to the bag. The bag is made from polyethylene and therefore a suitable material for the sensor holding part is polyethylene. However the material of the sensor 13 used in this example can not be attached to polyethylene. The press fit of the sensor attachment part 33 in the opening 34 in the bag attachment part 31 disclosed here in relation to Figure 3 is a way to solve this problem. The sensor attachment part 33 should be slightly bigger than the opening 34. Furthermore the sensor attachment part 33 is provided with a chamfer 35. This will give a radial pressure on the sensor attachment part 33 for the purpose of preventing leakage through the free press fit. This minimizes the risk of getting any liquid or dirt in the opening 37 below the sensor attachment part 33 where light will pass during the optical reading.

Furthermore, a locking shoulder 38 is provided in the opening 34 in the bag attachment part 31. The locking shoulder 38 should keep the sensor attachment part 33 in place after having been forced to pass said locking shoulder 38 when pressed fitted into the opening 34.

In this embodiment a circular piece of bag film 21 is also provided. This piece of bag film 21 is welded to the bag attachment part 31 around the central part of the bag attachment part 31 where the sensor 13 is provided. The purpose is to prevent any possible leakage outside the bag if such a leakage would occur through the press fit.

However, if the press fit really is leakage free and reliable this circular piece of bag film 21 would not be necessary.

In Figure 3 an adaptor part 41 is also shown attached to the sensor holding part 11. An optical fibre 7 is positioned into the adaptor part 41. A combined mirror and lens 39 is provided in the adaptor part 41 connected to the optical fibre 7. When the sensor holding part 11 and the adaptor part 41 are connected the combined mirror and lens 39 is provided right beneath the sensor in the sensor holding part 11. The combined mirror and lens 39 directs and focuses the light from the optical fibre 7 onto the sensor spot 13. The sensor 13 is hereby illuminated via the fibre 7 and the excited fluorescent sensor 13 emits light that is monitored via the fibre 7. The light paths are shown by arrows. With this arrangement the optical fibre is provided along the surface of the bottom part of the bag and the support structure needs not to be adapted in any way. The first and second locking parts keeping the sensor holding part and the adaptor part together will be further described below.

Figure 4a shows an adaptor part 41 according to one embodiment of the invention. Suitably the adaptor part is provided in a material that is stiffer than the material of the sensor holding part 11. One example of a suitable material for the adaptor part is polycarbonate. In Figure 4a it is shown how the first locking means 17 a, b, c, d of the sensor holding part 11 are fitted into second locking means 43 a, b, c, d, in the adaptor part 41 in a non locked position. However, the rest of the sensor holding part 11 is not shown in order to make it clearer. The second locking means 43 a, b, c, d are in this embodiment provided as four tracks on the circumference of a circle. The dimensions are adapted for receiving the first locking means 17 a, b, c, d of the sensor holding part 11. In this embodiment each track 43 a, b, c, d comprises guiding surfaces leading the hooks into a locking position, i.e. after having rotated the adaptor part 41 in relation to the sensor holding part 11 (as shown in Figure 4b) the first locking means 17 a, b, c, d have been guided into a second position within the tracks which is a locked position. These details are described in relation to Figure 5a and 5b.

Figure 4b shows the adaptor part of Figure 4a in a locked position.

Figure 5a is a closer view of the locking mechanism in one embodiment of the invention before locking. One first locking means 17a in the form of a hook is shown inserted into one second locking means 43a in the form of a track. A radial guiding surface 44 on the inner surface of the track 43a is provided for guiding a corresponding hook guiding surface 46 on the hook 17a into a radial locked position. Possibly the hook 17a is also pressed somewhat outwardly by the guiding surface 44. Furthermore a locking bump 45 is shown in the track 43a. A gripping part 48 of the hook 17a will be caught by an inclined surface 42 of the track leading up to the locking bump 45 and the hook 17a will pass over the locking bump 45 when the adaptor part 41 is rotated in relation to the sensor holding part 11. The purpose of the locking bump 45 is to prevent the hook 17a from rotating back.

Figure 5b is the same view as Figure 5a but in locked position, i.e. the adaptor part has been rotated to a locked position. Because all four locking parts provided in a circle are locked and because the locking mechanism is securing the adaptor part 41 in relation to the sensor holding part 11 in all directions the combined mirror and lens 39 of the adaptor part 41 can be kept steadily in relation to the sensor 13. Furthermore, this locking mechanism provides a very low tension stress on the sensor holding part. This is important because the sensor holding part is made from polyethylene and this material tends to be subjected to creepings/relaxation. Hereby the risk for creeping/relaxation in the sensor holding part is reduced to a minimum by the locking mechanism described here.

Figure 6 is a cross section view showing the sensor holding part 11 being locked in the adaptor part 41 according to one embodiment of the invention. In this view a contact surface 49 between the sensor holding part (possibly through the piece of bag film 21) and the adaptor part 41 can be seen. When the gripping part 48 of the hook 17 is pressed by the track 43 into the locked position the sensor holding part and the adaptor part will come into contact at contact surface 49 (possibly through the piece of bag film 21). This

contact is important because the distance between the sensor and the combined mirror and lens need to be kept constant and contact surfaces pressed towards each other. This will work well if the tension stress is kept at a minimum level and therefore reduces the risk for creeping of the sensor part.

Figure 7a shows another embodiment of a sensor holding part 51 where the sensor holding part is separated into an inner sensor holding part 53 and an outer locking part 55. Figure 7b is an exploded view of the sensor holding part of Figure 7a. In this embodiment the bag 65 needs not to be penetrated by the first locking means. The bioreactor bag surface can be kept intact. This could be good for preventing any contamination risk for the cell growth process. First locking means 57 are provided on the outer locking part 55. The inner sensor holding part 53 is welded to the bag surface and it comprises the sensor 59 in the middle facing the interior of the bag. The sensor attachment arrangement is suitably the same as described in relation to Figure 3. The outer sensor holding part 55 is welded to the outside of the bag. The inner sensor holding part 53 and the outer locking part 55 will be welded together by bending the bag 65 according to Figure 7a and then an inner bag support ring 61 and an outer bag support ring 63 will be welded on top and on the bottom and secure the assembly. The adaptor part is suitably the same as described in relation to Figure 4a and 4b.

Figures 8a-8d shows four different embodiments of adaptor parts according to the invention. Of course both the first and second locking means of the invention can be designed in different forms. The result that should be achieved is a locking position where the two parts are kept together and are locked together in all directions.

Furthermore the geometry of the locking is important such that any creeping in the sensor holding part can be prevented. Four alternative embodiments of the adaptor part are shown in Figures 8a-8d where Figure 8a shows the adaptor part already described in relation to Figures 4 and 5. In this embodiment the locking is made in axial direction. The embodiments shown in Figures 8b, 8c and 8d provide a locking in radial direction.

The sensors described above are optical sensors. These could be for example sensors for pH, DO, carbondioxide (CO₂), biomass, UV detection and IR detection.

Figure 9a and 9b show schematically another embodiment of the invention where the first and second locking parts are designed differently. A sensor holding part 91 is shown having four first locking means 93a, b, c, d in the form of plugs with larger heads 95a, b, c, d. An adaptor part 97 is also shown having four second locking means 99a, b, c, d in the form of receiving holes. In Figure 9b one of the second locking means 99a is shown in cross section. The second locking means 99a comprises a retaining means 101a in the form of a section in the receiving hole having a smaller diameter than the rest of the hole and edges adapted for letting the larger head 95a of the first locking means 93a pass through the retaining means 101a when a force is applied from above. The edges of the retaining means 101 are further adapted for retaining the head 95a below the retaining means 101 when it has been pressed down there. A sensor is provided in the middle of the sensor holding part in the same way as described in for example relation to Figure 2a and b and an optical fibre is provided in the adaptor part in the same way as described in relation to Figure 3. There are of course many other possible ways of designing the first and second locking means.

One important benefit with the invention is that a support structure provided under the flexible bag need not be adapted in any way to the sensor attachment arrangement. The bag can be freely moved together with the sensor attachment arrangement and be used in any system. Another feature of the sensor attachment arrangement is that it is very flat and of low height. This is advantageous since it is important that its effect on the mixing of the culture in the bioreactor bag by protruding into the bag is limited. At the same time also small volumes of culture in the bag will cover the sensor. The different locking mechanisms described above and the mirror provided in the adaptor part are both important components in making the sensor attachment arrangement as flat as possible.