



- (51) **International Patent Classification:**
A63B 71/00 (2006.01) *A61G 5/10* (2006.01)
- (21) **International Application Number:**
PCT/IB2019/053108
- (22) **International Filing Date:**
16 April 2019 (16.04.2019)
- (25) **Filing Language:** Italian
- (26) **Publication Language:** English
- (30) **Priority Data:**
102018000004667 18 April 2018 (18.04.2018) IT
- (71) **Applicant:** **EVOWELL ITALY SRLS** [IT/IT]; Via Giuseppe Petraglione 20, 70125 Bari (IT).
- (72) **Inventor:** **BORNETI, Pierluigi**; c/o Evowell Italy Srls, Via Giuseppe Petraglione 20, 70125 Bari (IT).
- (74) **Agent:** **LEONE, Mario** et al.; Cantaluppi & Partners S.r.l., Via XX Settembre 98/G, 00187 Roma (IT).
- (81) **Designated States** (*unless otherwise indicated, for every kind of national protection available*): AE, AG, AL, AM, AO, AT, AU, AZ, BA, BB, BG, BH, BN, BR, BW, BY, BZ, CA, CH, CL, CN, CO, CR, CU, CZ, DE, DJ, DK, DM, DO, DZ, EC, EE, EG, ES, FI, GB, GD, GE, GH, GM, GT, HN, HR, HU, ID, IL, IN, IR, IS, JO, JP, KE, KG, KH, KN, KP, KR, KW, KZ, LA, LC, LK, LR, LS, LU, LY, MA, MD, ME, MG, MK, MN, MW, MX, MY, MZ, NA, NG, NI, NO, NZ, OM, PA, PE, PG, PH, PL, PT, QA, RO, RS, RU, RW, SA, SC, SD, SE, SG, SK, SL, SM, ST, SV, SY, TH, TJ, TM, TN, TR, TT, TZ, UA, UG, US, UZ, VC, VN, ZA, ZM, ZW.
- (84) **Designated States** (*unless otherwise indicated, for every kind of regional protection available*): ARIPO (BW, GH, GM, KE, LR, LS, MW, MZ, NA, RW, SD, SL, ST, SZ, TZ, UG, ZM, ZW), Eurasian (AM, AZ, BY, KG, KZ, RU, TJ, TM), European (AL, AT, BE, BG, CH, CY, CZ, DE, DK,

(54) **Title:** COOPERATION SYSTEM BETWEEN A WHEELCHAIR AND EXERCISING DEVICE

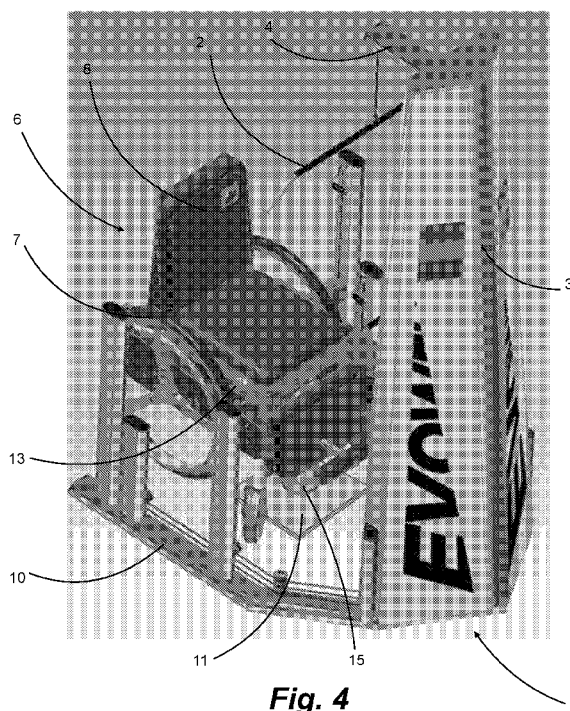

Fig. 4

(57) **Abstract:** A cooperation system between a wheelchair and exercisers, allows both a control of the wheelchair's positioning and a locking thereof in a position for the gym exercise, the whole easily controllable by the user, without external aid, and on this regard it comprises: at least a magnetic hooking plate (11), fastened with respect to the exerciser (1) with a predetermined spatial correlation; extensible magnetic means aboard a wheelchair (6), extending therefrom to said at least a hooking plate (11), by determining a mutual positioning between wheelchair (6) and exerciser (1), suitable to perform exercises; and means (13) for driving said extensible magnetic means aboard a wheelchair (6), which can be actuated by the wheelchair's user in seated position from an unlocking position to a locking position and vice versa.



EE, ES, FI, FR, GB, GR, HR, HU, IE, IS, IT, LT, LU, LV,
MC, MK, MT, NL, NO, PL, PT, RO, RS, SE, SI, SK, SM,
TR), OAPI (BF, BJ, CF, CG, CI, CM, GA, GN, GQ, GW,
KM, ML, MR, NE, SN, TD, TG).

Published:

— *with international search report (Art. 21(3))*

COOPERATION SYSTEM BETWEEN A WHEELCHAIR AND EXERCISING DEVICE**Description**

The present invention relates to a cooperation system between a wheelchair and exercisers, of the gym type,
5 which can be used by people confined to a wheelchair.

As it is known, the awareness to guarantee to people having handicaps the occasions to practice sport and to take care of physical fitness has been increasing.

The fact of performing sporting activities and keeping
10 satisfying physical conditions is at the basis of a newly found psycho-physical wellbeing which allows people suffering from a handicap to improve his/her own life style and found again trust in one's own means.

A difficulty which is particularly felt is that of being
15 able to use, for a person without using legs and confined on a wheelchair, usual exercisers for muscle strengthening, of the type which can be commonly found in any gym.

Some system examples are known allowing the cooperation
20 between a wheelchair and an exerciser.

For example, International patent application No. WO 2015/079,468 A1 describes an alignment system between a wheelchair and a gym exerciser, to guarantee their mutual correct positioning. US patent application No. US
25 2007/299,371 A1 describes a similar cooperation system applied to an apparatus for the rehabilitation of patients with motor problems.

International patent application No. WO 2011/047,282 A2 describes a particular exerciser which can be used even
30 by people confined on a wheelchair, wherein a system for the mechanical fastening to rails for the wheelchair is described.

International application No. 2009/126,904 A2, on the contrary, describes a *tapis roulant* which can be used in
35 wheelchair, wherein mechanical sensors cooperate with a mechanical system to verify the asset of the wheelchair on the conveyor belt.

Chinese patent applications No. CN 107 456 353 A and No. CN 104 887 421 A and Japanese patent application No. JP 2002/065,802 describe additional fastening systems between wheelchairs.

- 5 The above-described systems help a user to determine his/her own position with respect to an exerciser, but they are complex to use, and at last they do not guarantee an optimum fastening of the wheelchair, but only a control of its correct position, to be re-examined
10 in case of misalignment.

The technical problem underlying the present invention is to provide a cooperation system between a wheelchair and any exerciser allowing to obviate the drawback mentioned with reference to the known art.

- 15 Such problem is solved by a cooperation system as defined by the enclosed claim 1.

- The main advantage of the cooperation system according to the present invention lies in the fact of allowing both a control in the positioning of the wheelchair and a
20 locking thereof in a position for the gym exercise, the whole easily controllable by the user, without external aid.

- The present invention will be described hereinafter according to a preferred embodiment example, provided by
25 way of example and not with limitative purposes, with reference to the enclosed drawings wherein:

- * figure 1 shows a side perspective view of a LAT machine and of wheelchair incorporating a first cooperation system according to the invention;
- 30 * figure 2 shows a rear perspective view of a LAT machine and of a wheelchair incorporating the highlighted cooperation system of figure 1;
- * figure 3 shows an enlarged perspective view of the cooperation system of figure 1;
- 35 * figure 4 shows a side perspective view of a LAT machine and of a wheelchair incorporating a second cooperation

system according to the invention;

* figure 5 shows a side perspective view of a pedal board for arms and of a wheelchair incorporating the second cooperation system of figure 4;

5 * figure 6 shows an enlarged perspective view of the cooperation system of figure 4;

* figure 7 shows a perspective view of another model of LAT machine and of a wheelchair with said second cooperation system;

10 * figure 8 and figure 9 show respective perspective views of LAT machine highlighting a different cooperation system according to the invention;

* figure 10 shows a perspective view di una wheelchair highlighting a cooperation system according to the
15 invention;

* figure 11 shows a support for rocker arms highlighting a cooperation system according to the invention;

* figures 12 and 13 show respective enlarged perspective views of two variants of a third cooperation system
20 according to the invention; and

* figure 14 and figure 15 show respective perspective views of additional exerciser with curved beams highlighting a different cooperation system according to the invention.

25 With reference to figures 1 to 4, a so-called LAT machine designated with 1 is represented, that is an exercise machine to perform lifting exercises with an overhead handlebar 2, to the benefit of the large dorsal muscle.

Here, the LAT machine, called in this way from the muscle name (*musculus latissimus dorsi*) represents a general
30 exerciser which can be actuated by a user in wheelchair. Hereinafter, each device suitable to this purpose will be generally designated with 1.

The LAT machine 1 comprises an upright 3 and a cross arm

4, with a pulley connected to the handlebar 2 for lifting one or more calibrated weights which can be selected by the user.

5 The LAT machine 1 further defines a position wherein a wheelchair 6, equipped with the herein described cooperation system, can be parked. It comprises wheels 7 and a seat 8, with a backrest with adjustable tilting.

The wheels 7 are of the type which can be manoeuvred manually, thanks to a circular handle 9.

10 Herein and hereinafter, under wheelchair then a wheelchair, in particular a self-propelled wheelchair, is identified, which a user can use with a great level of autonomy.

15 In particular, the herein represented wheelchair represents an exerciser suitably created to assume several positions in the space through actuators, in particular electromechanical actuators which are fed by a rechargeable battery arranged aboard the wheelchair.

20 Said actuators allow the portions of the wheelchair to assume in the space several positions, that is the wheelchair allows the user to position in optimal way to perform the muscle exercise.

In particular, the following motions are provided:

- motion of backrest from 0° to 90°,
- 25 • motion of the plate supporting the legs from 0° to 90°,
- oscillating motion of the seat placed under the thighs from 0° to 45°,
- motion from bottom to top of the whole structure,

30 these four motions are controlled electrically by means of a button panel arranged on the side of the user.

The position in front of the LAT machine can be taken by the wheelchair, and it is defined by side frame elements 10, of the LAT machine 1, surrounding laterally said
35 position.

Respective magnetic hooking plates 11 are fastened to the side frame elements 10, which in the present example have the shape of horizontal bars, one for each side of the above-mentioned position.

5 It is meant that there can be present, on each side, several bars having the function of magnetic hooking plate. Each one thereof can be made of ferromagnetic material, or have on its own surface directed towards the position a strip of magnetic material.

10 On each bar there can be indicators or pointers, or positioning notches.

The position of the plates 11 is so as to generate a predetermined spatial correlation with the exerciser, thanks to the size limits, referred in this case to the
15 ends of the bars, which the plate 11 imposes.

At the hubs of the wheels 7, the wheelchair 6 comprises extensible magnetic means, received aboard the wheelchair 6, extending therefrom to said at least a hooking plate 10.

20 In the present example, such magnetic means is constituted by a magnet 12, existing on each hub of the wheel 7, which can be extended telescopically until reaching the side plate 10.

The extension of the magnet 12 until the magnetic
25 contact, which implements a lock, with the plate 10 determines a mutual positioning between wheelchair and exerciser, which is limited to the extension of the bar which implements the fastening plate 10, and which is suitable to perform exercises with the LAT machine 1.

30 The magnet 12 can be driven by a control lever 13 which implements means for driving said extensible magnetic means aboard a wheelchair 6.

Each lever 13 is positioned so as to be able to be reached by the user on the wheelchair autonomously, by
35 remaining in seated position; the lever 13 can control the magnet 12 from an unlocking position (figure 3) to a locking position (figure 2) and vice versa, by exerting a

modest muscle force.

It is to be noted that the length of the side bars 11 define a standing area of the wheelchair 1 during the exercises, both it enters forward in the position of the machine 1, and it enters backward, thus allowing the user to carry out several types of exercises.

With reference to figure 4, the fastening plate 11 in this case is single and it is positioned on the floor of the position defined by the LAT machine. It is to be meant that the plate could be positioned on the floor supporting the exerciser, or otherwise the plate could be fastened to a footboard integral to the exerciser.

In the present example, the fastening plate 11 has a square shape, with a front side and a rear side defining a spatial correlation between it and the exerciser.

Again, the width of the fastening plate 11 defines a standing area of the wheelchair 1 during the exercises, both it enters forward in the position of the machine 1, and it enters backward, thus by allowing the user to carry out several types of exercises.

The wheelchair 6, at the bottom thereof, has an extensible arm 14 having, on the end thereof faced towards the floor, a magnetic plate 15 adhering to the fastening plate 11.

The extensible arm 14, and thus the magnetic plate, is controlled by a lever 13 positioned on the side of the wheelchair 6, still in a position accessible by the user.

In the herein described examples, the fastening plate is ferromagnetic, whereas aboard the wheelchair 6 there is a magnet or a magnetic plate, capable of adhering to the fastening plate 11 thanks to the effect of their magnetic properties induced by the presence of one or more permanent magnets.

It is meant, however, that the fastening can be of electromagnetic type; in this case the magnetic plate 15 is activated electromagnetically by an electric circuit fed by a battery aboard the wheelchair 6.

The extensible arm 14 can be controlled in extension and contraction by an electric motor arranged below the seat 8. Both the actuation of the arm 14 and the activation of the magnetic plate 15 can be controlled by a button panel 5 16 arranged on the side of the wheelchair 6, still in a position accessible by the user.

With reference to figures 7 to 9 a LAT machine is shown both in the version with ground fastening plate (figures 7 and 9) and in the version with side bars (figure 8).

10 It is known that, in both cases, a positioning area of the wheelchair 6 is defined implemented by the ends of the plate and of the fastening bars, beyond thereof the wheelchair cannot go, but within thereof the user can select its favoured position to perform the exercises 15 with the exerciser.

It is further to be noted that, due to the effect of the side positioning of the bars and the central positioning of the fastening plate, the wheelchair 6 will be automatically centred with respect to the exerciser. It 20 is to be meant that additional aids to the positioning could be added, if required, including optical control devices, with photoelectric cells and retro reflectors, or mechanical control devices, with insertion lanes, stopping notches or positioning recesses of the wheels 8 25 of the wheelchair.

With reference to figure 11, an additional gym device, this time a simple support for rocker arms 17, can be provided both with side fastening bars and central fastening plate.

30 With reference to figures 12 and 13, a magnetic version is shown with side extensible arm 18 projecting from the flank of the wheelchair 6. The extensible arm 18 herein is received in a tubular guide 19 and it is controlled in extension or contraction by a lever 13, arranged on the 35 side of the wheelchair 6, still in a position accessible by the user.

This solution allows to adapt wheelchairs of small sizes to wide positions.

With reference to figures 14 and 15, a different machine for the fitness is shown, which exploits the sliding of weights, pushed or pulled by the user, along arch-like curved beams, standing over the position wherein the wheelchair 6 positions. This machine with curved beams can have both the cooperation system with side bars and that with the plate for central fastening to floor.

To the above described cooperation system a person skilled in the art, with the purpose of satisfying additional and contingent needs, could introduce several additional modifications and variants, however all within the protective scope of the present invention, as defined by the enclosed claims.

CLAIMS

1. A cooperation system between a wheelchair and exercisers, comprising:
- 5 • at least a magnetic hooking plate (11), fastened with respect to the exerciser (1) with a predetermined spatial correlation;
 - 10 • extensible magnetic means aboard a wheelchair (6), extending therefrom to said at least a hooking plate (11), by determining a mutual positioning between wheelchair (6) and exerciser (1), suitable to perform exercises; and
 - 15 • means (13) for driving said extensible magnetic means aboard a wheelchair (6), which can be actuated by the wheelchair's user in seated position from an unlocking position to a locking position and vice versa.
2. The cooperation system according to claim 1, wherein the exerciser (1) defines a parking position of the wheelchair (6), in case defined by side frame elements
- 20 (10) surrounding laterally said position.
3. The cooperation system according to claim 2, wherein said at least a magnetic hooking plate comprises horizontal bars, one for each side of the above-mentioned position, fastened to the side elements, with
- 25 ferromagnetic properties, having respective ends defining a positioning area of the wheelchair (6).
4. The cooperation system according to claim 2, wherein said at least a magnetic hooking plate comprises a fastening plate (11) with square shape, with a front side
- 30 and a rear side defining a spatial correlation between it and the exerciser, positioned on the floor of said position or fastened to a footboard integral to the exerciser (1).
5. The cooperation system according to claim 1, wherein
- 35 said extensible magnetic means comprises at least a magnet (12) arranged laterally on the wheelchair (16) and extensible laterally with respect thereto.

6. The cooperation system according to claim 1, wherein said extensible magnetic means comprises an extensible arm (14) having, on the end thereof faced towards the floor, a magnetic plate (15) adhering to the fastening
5 plate (11).

7. The cooperation system according to claim 1, wherein said driving means comprises at least a lever (13) which is positioned so as to be able to be reached by the user on the wheelchair autonomously, by remaining in seated
10 position.

8. The cooperation system according to claim 1, wherein the magnetic means comprises permanent magnets.

9. The cooperation system according to claim 1, wherein the magnetic means is of electromagnetic type, activated
15 by an electric circuit fed by a battery aboard the wheelchair (6) and controlled by a button panel (16) arranged on the side of the wheelchair (6), still in a position accessible by the user.

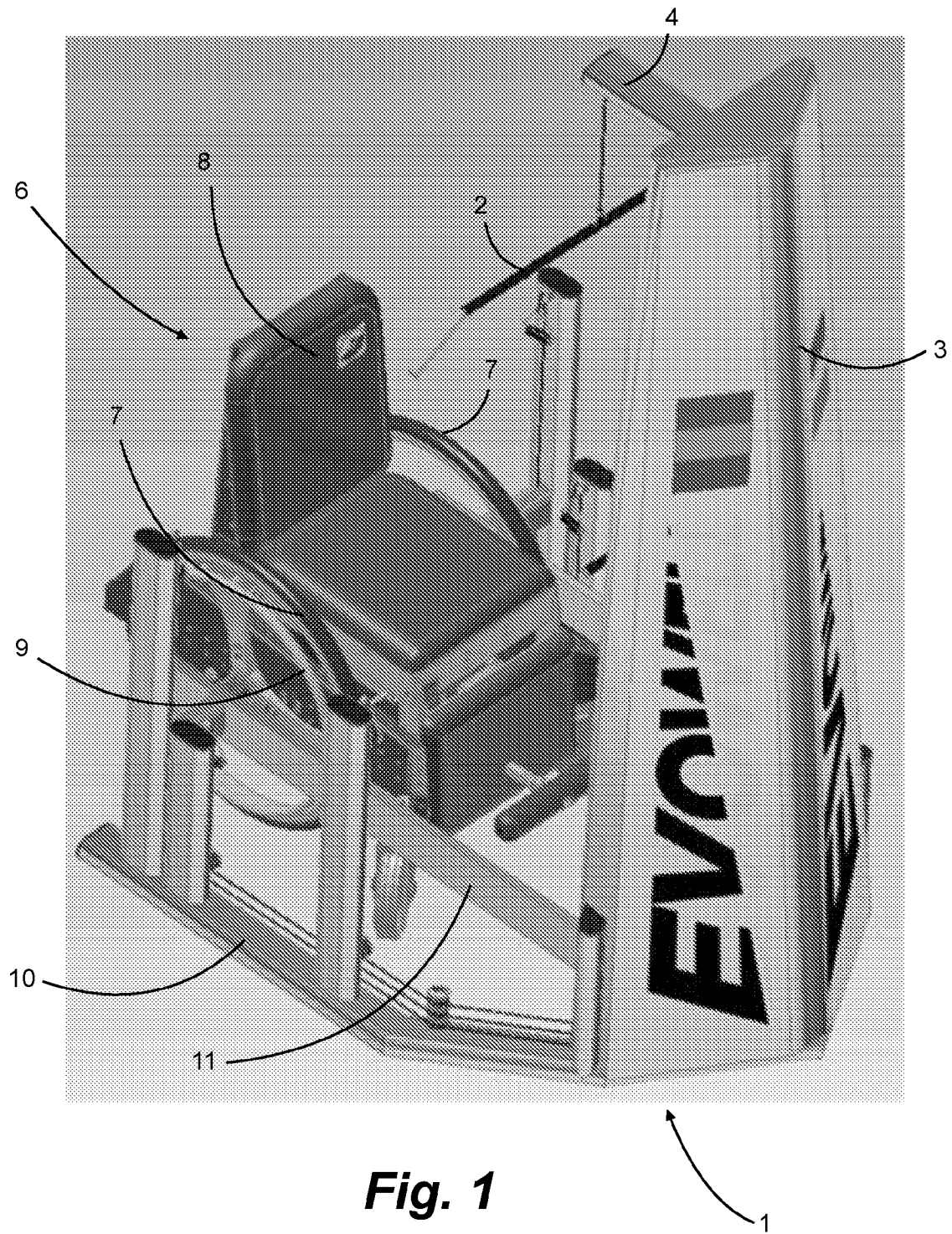

Fig. 1

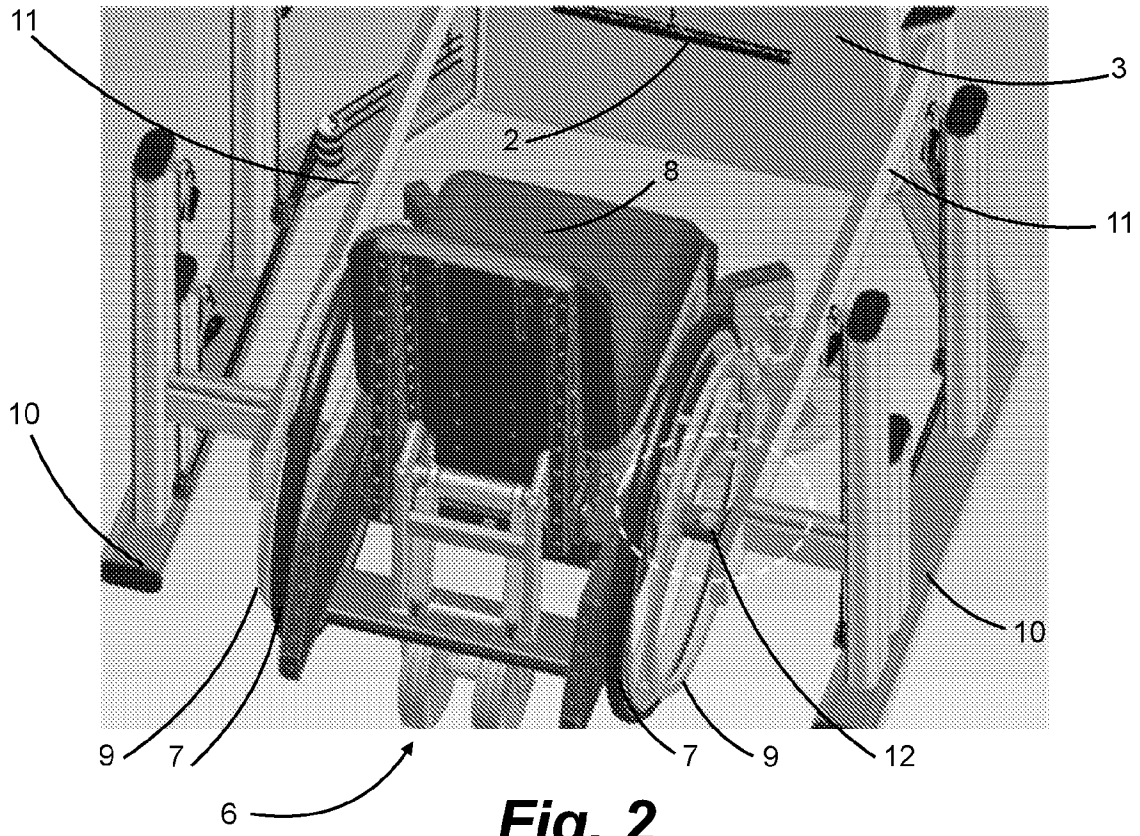

Fig. 2

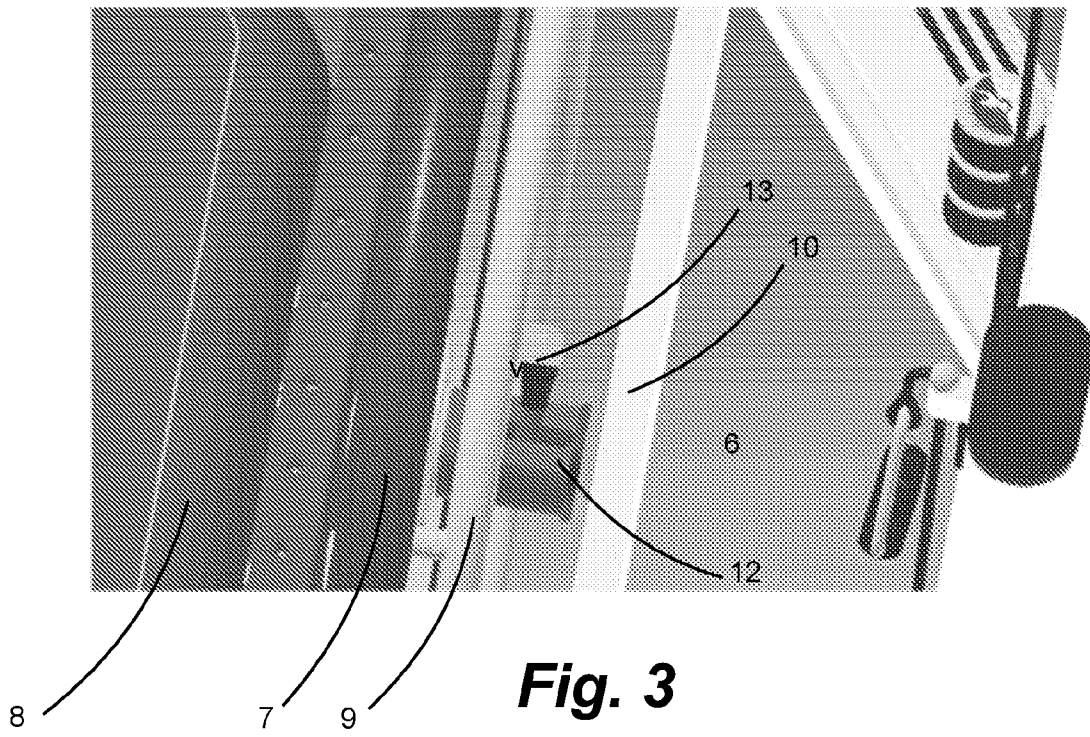

Fig. 3

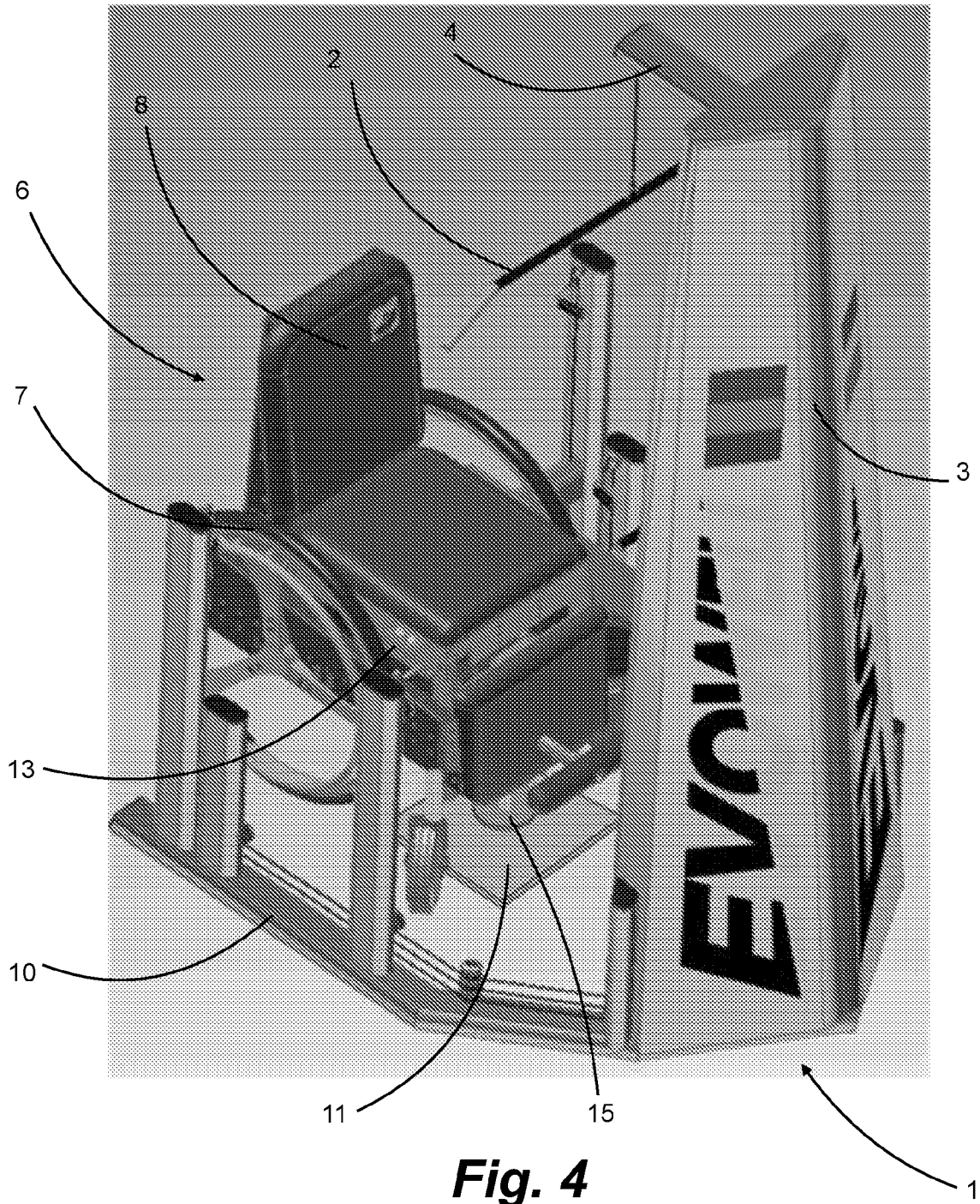

Fig. 4

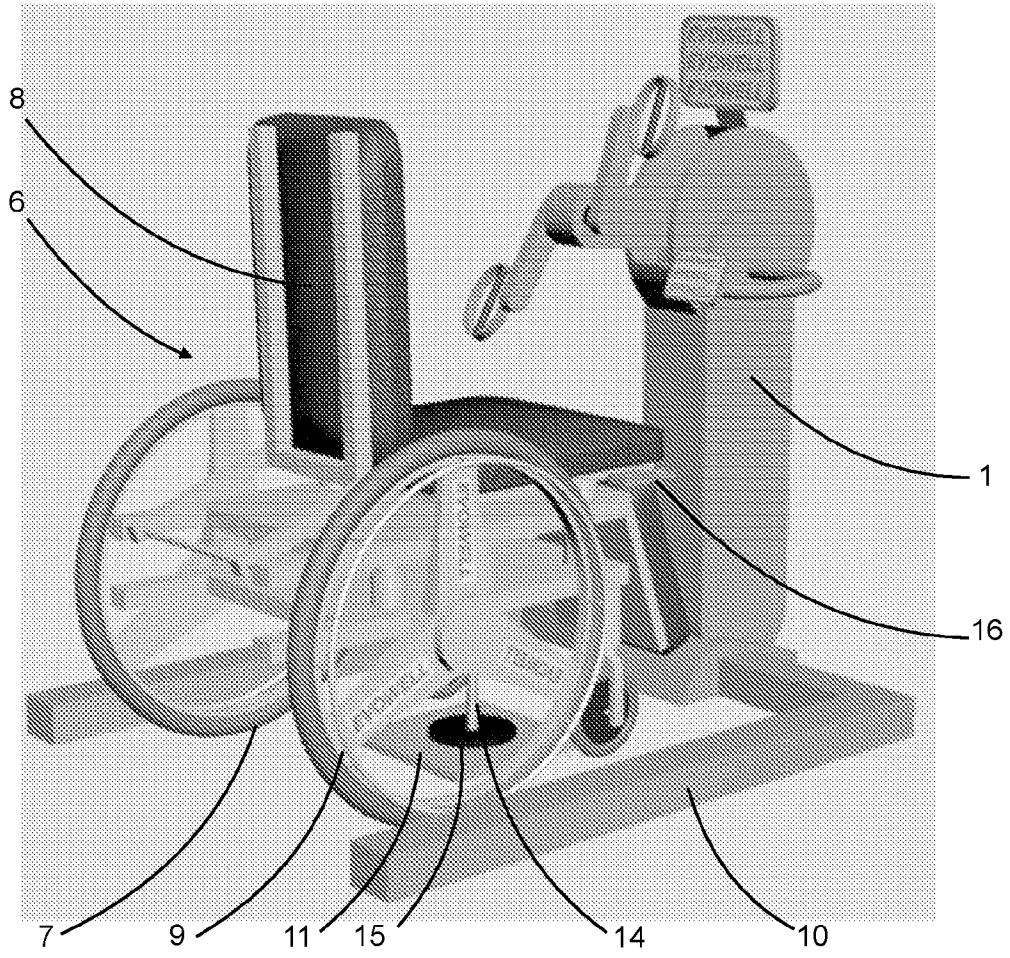

Fig. 5

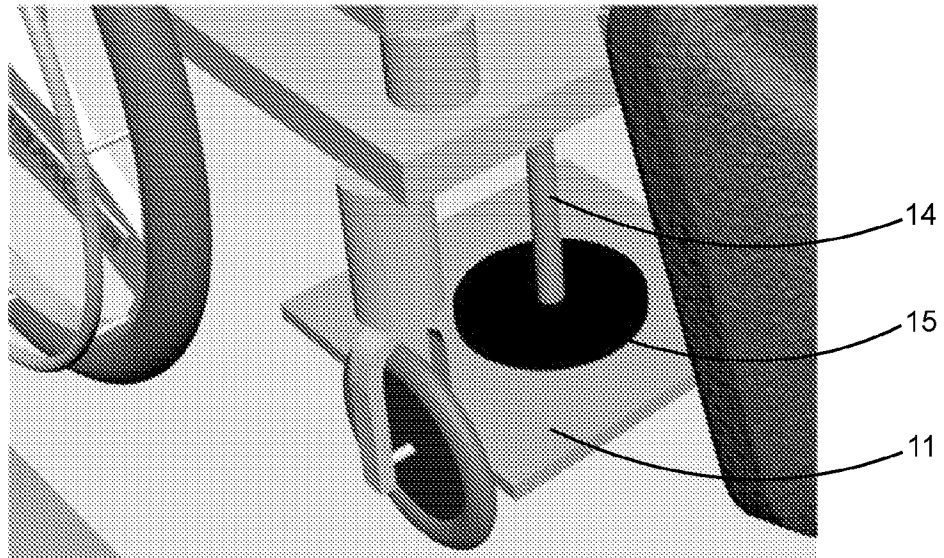

Fig. 6

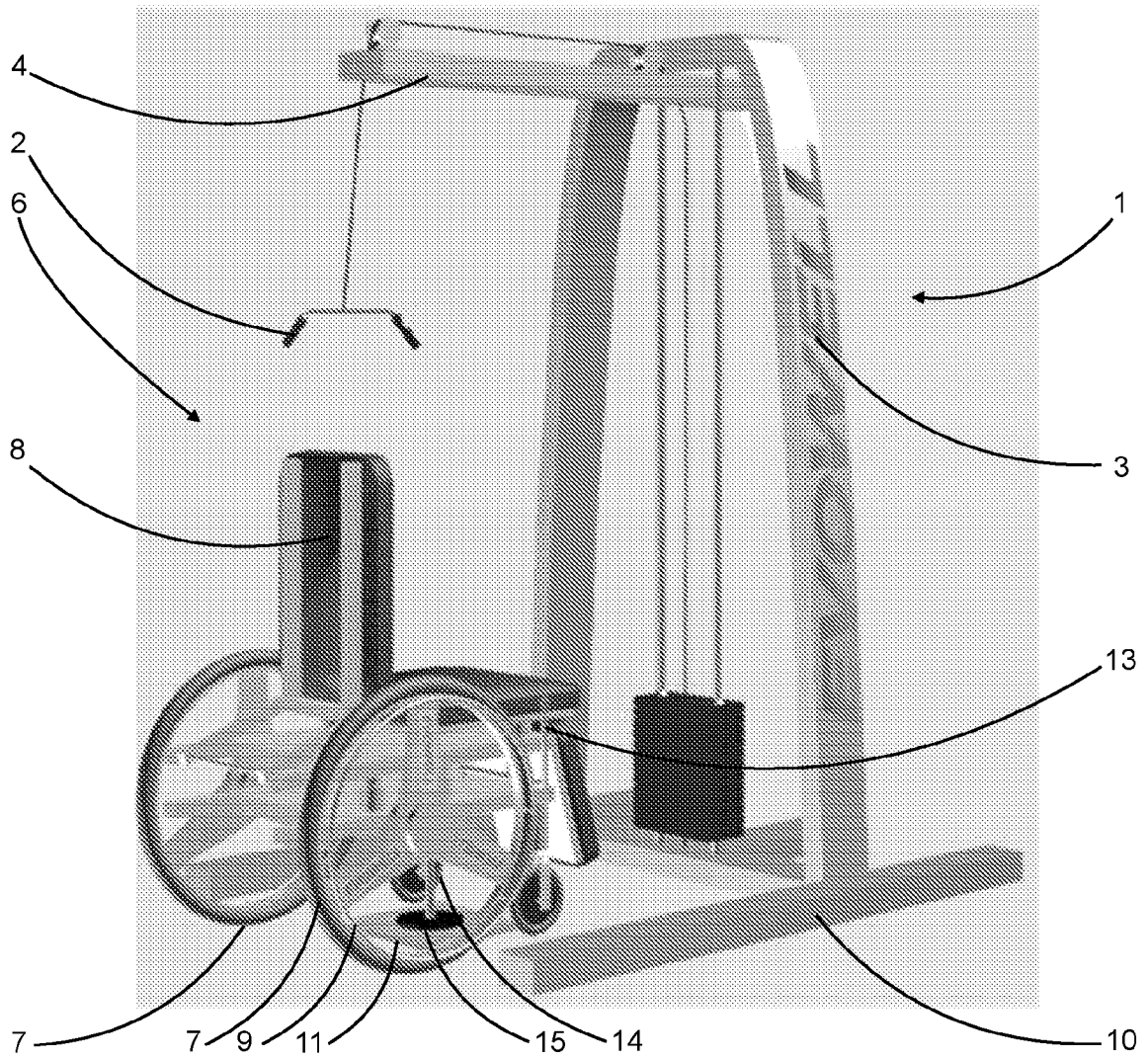

Fig. 7

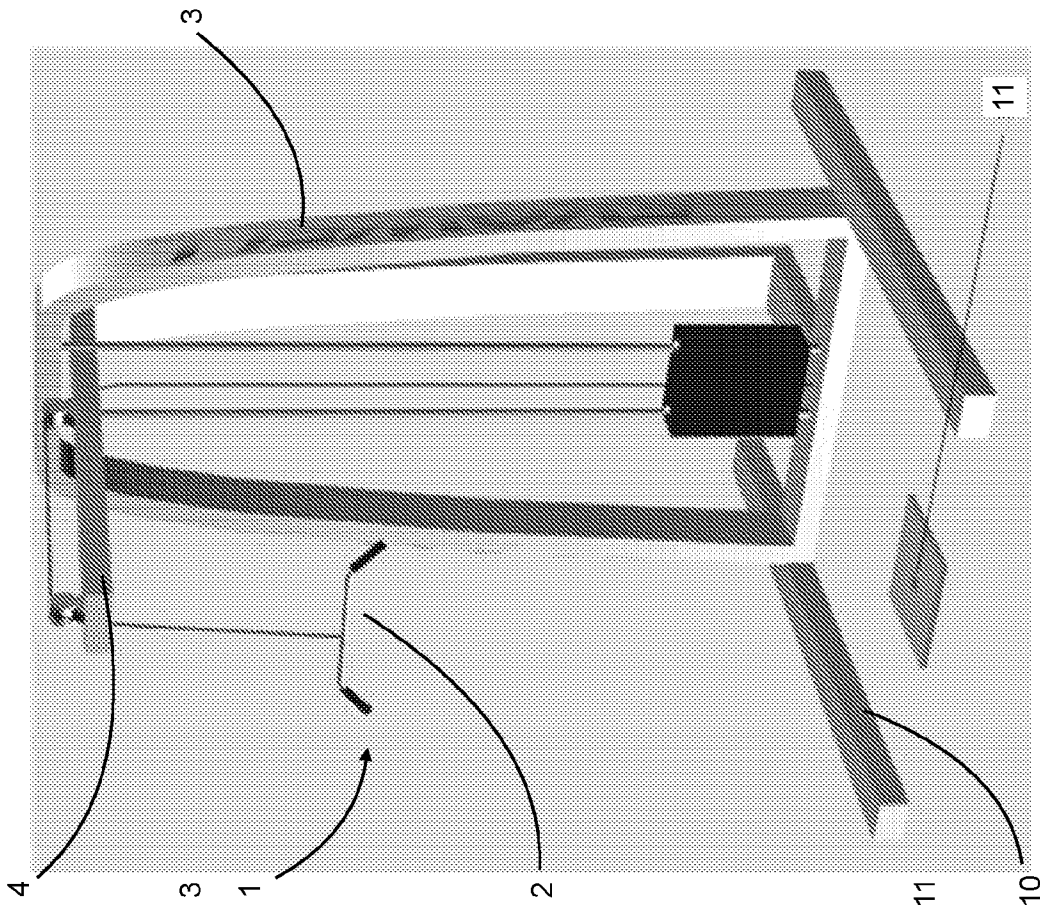

Fig. 8

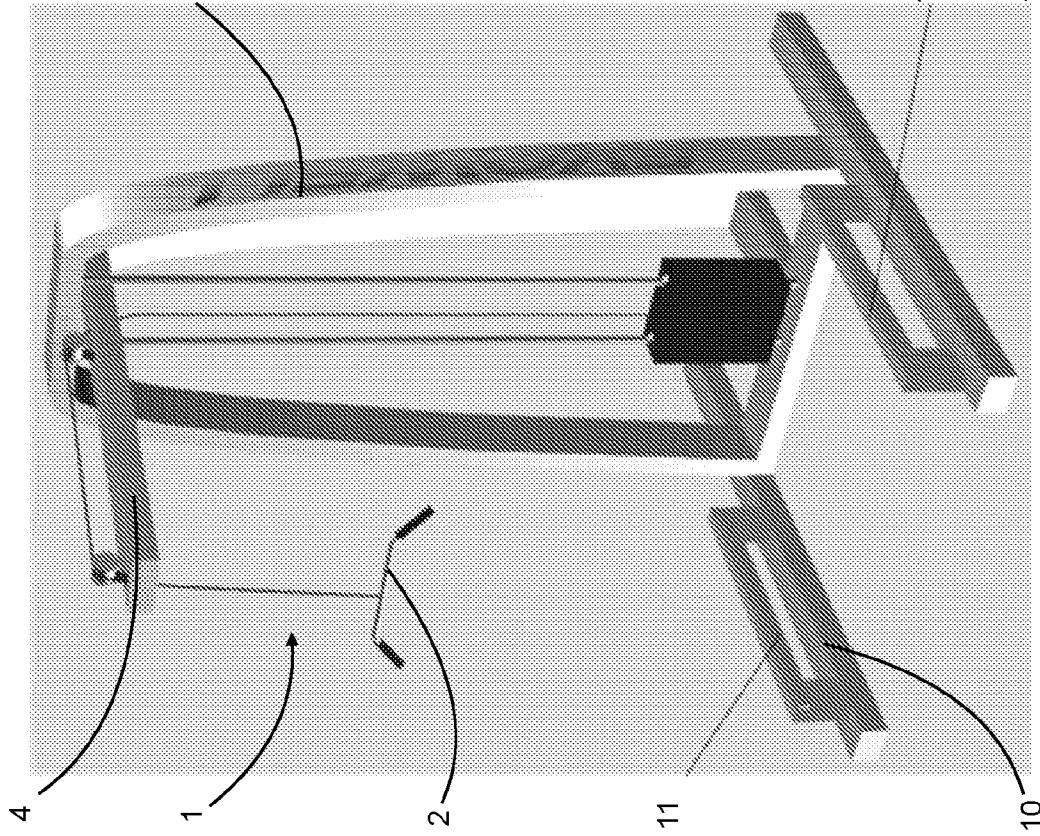

Fig. 9

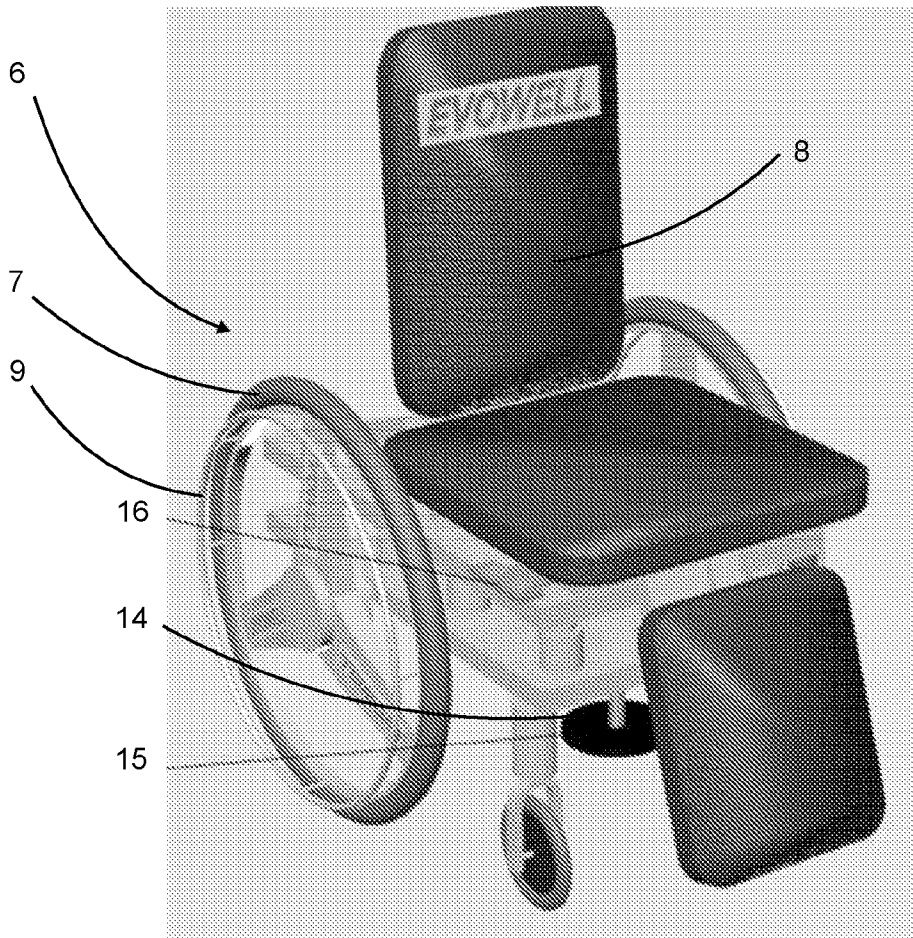

Fig. 10

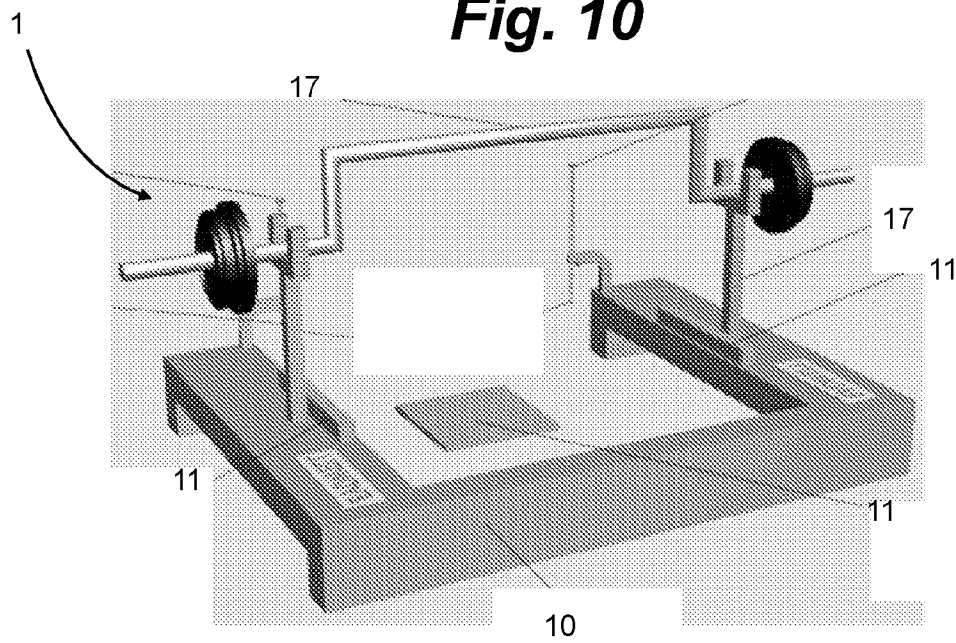

Fig. 11

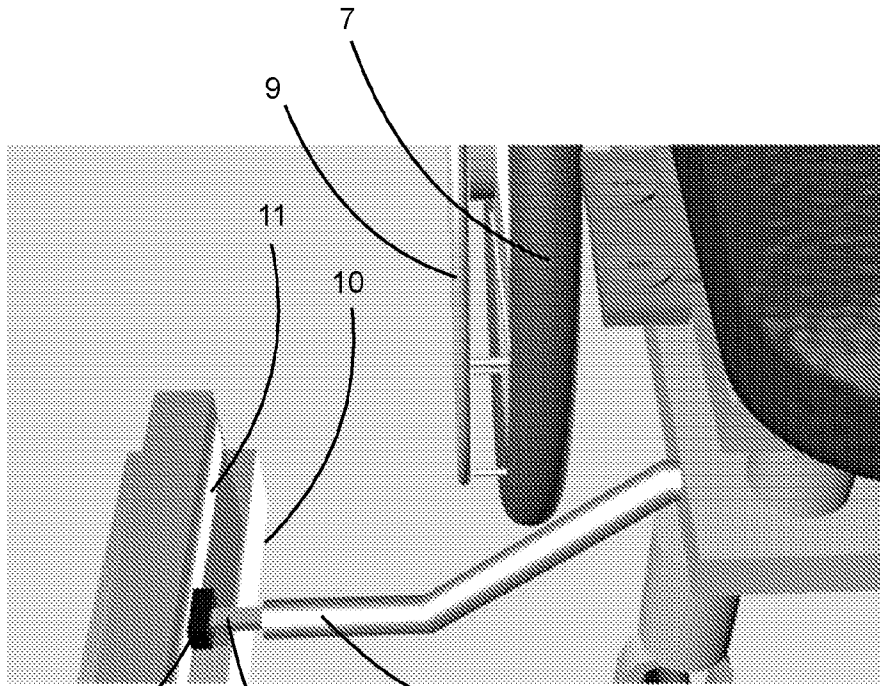

Fig. 12

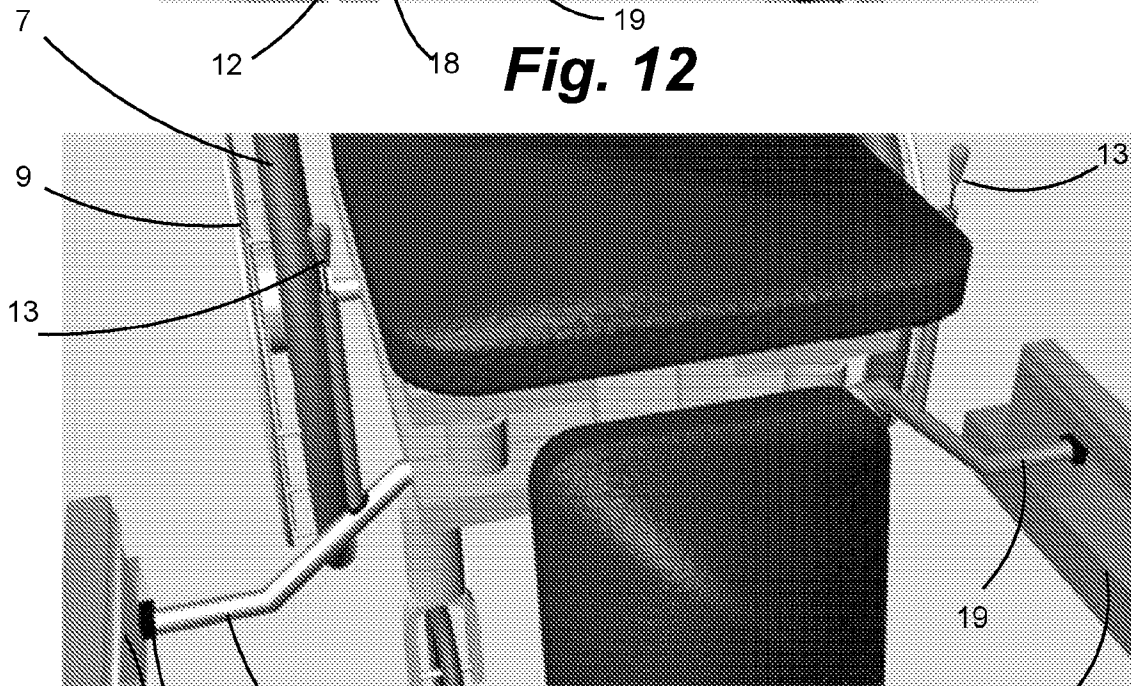

Fig. 13

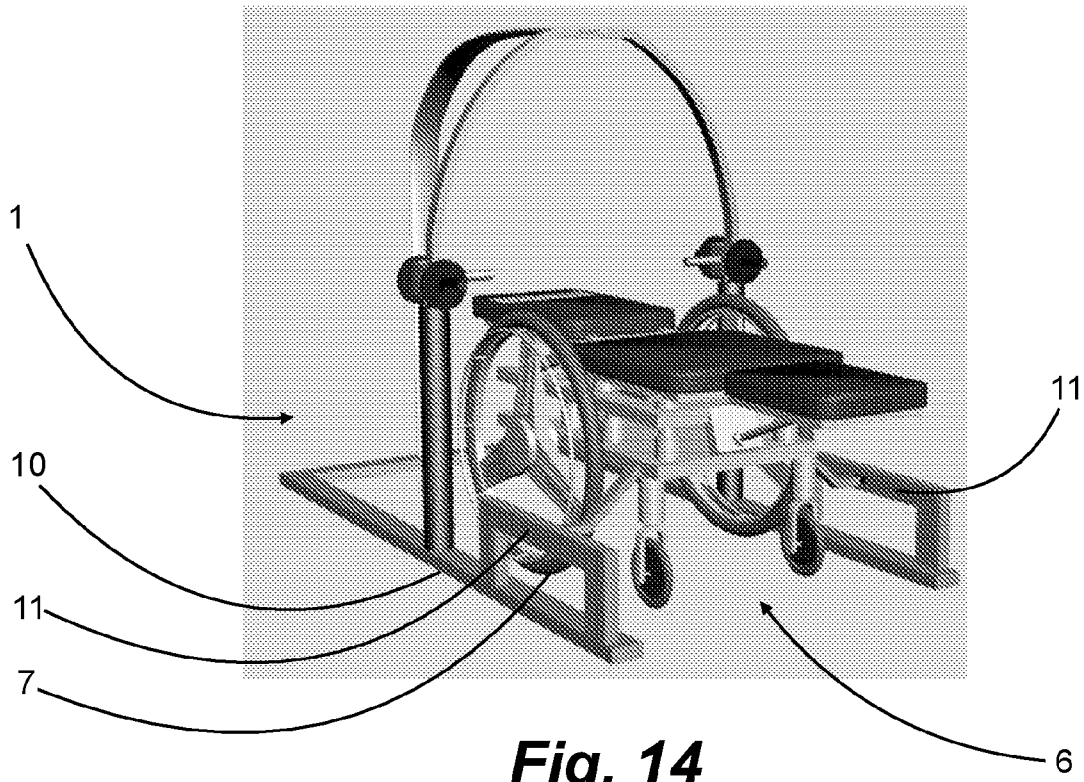

Fig. 14

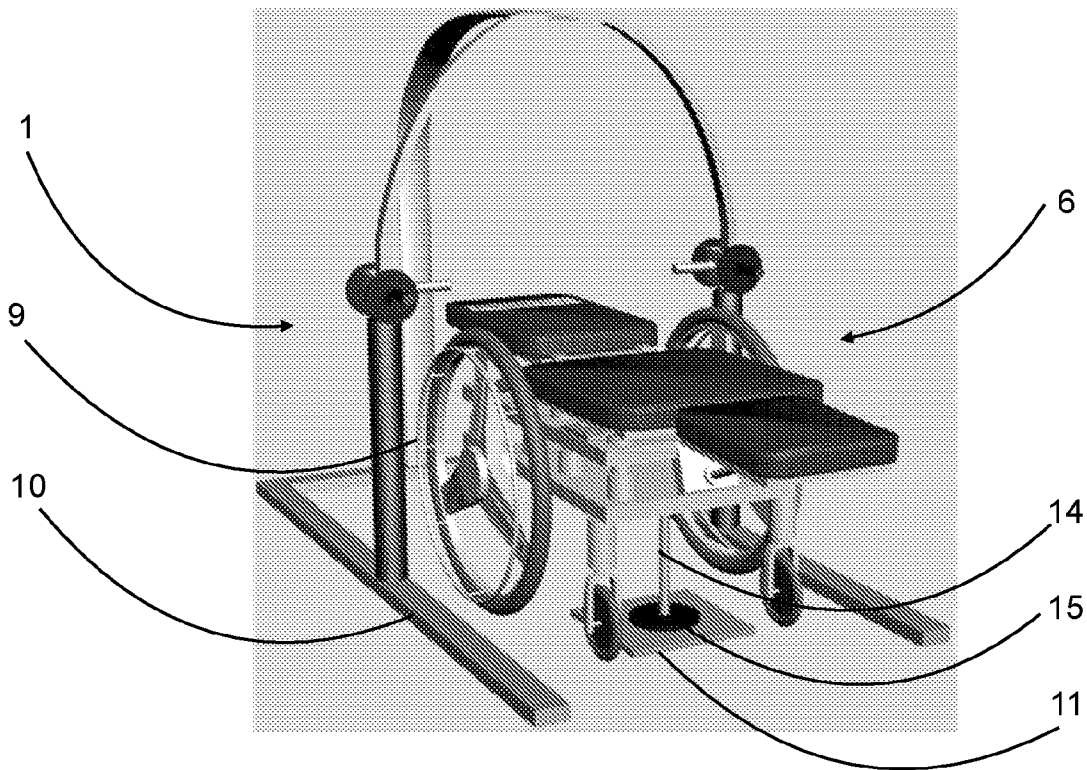

Fig. 15

INTERNATIONAL SEARCH REPORT

International application No PCT/IB2019/053108
--

A. CLASSIFICATION OF SUBJECT MATTER
 INV. A63B71/00 A61G5/10
 ADD.
 According to International Patent Classification (IPC) or to both national classification and IPC

B. FIELDS SEARCHED
 Minimum documentation searched (classification system followed by classification symbols)
A63B A61G
 Documentation searched other than minimum documentation to the extent that such documents are included in the fields searched

Electronic data base consulted during the international search (name of data base and, where practicable, search terms used)
EPO-Internal, WPI Data

C. DOCUMENTS CONSIDERED TO BE RELEVANT

Category*	Citation of document, with indication, where appropriate, of the relevant passages	Relevant to claim No.
A	CN 107 456 353 A (UNIV ZHEJIANG TECHNOLOGY) 12 December 2017 (2017-12-12) figures	1-9
A	----- JP 2002 065802 A (SEIKI KOGYO KK) 5 March 2002 (2002-03-05) paragraph [0060]; figures	1-9
A	----- CN 104 887 421 A (UNIV NANCHANG) 9 September 2015 (2015-09-09) paragraph [0010]; figures	1-9
A	----- US 5 277 685 A (GONZALES PHILLIP [US]) 11 January 1994 (1994-01-11) the whole document	1-9
A	----- US 5 362 297 A (MUIR ARTHUR M [US]) 8 November 1994 (1994-11-08) the whole document	1-9

Further documents are listed in the continuation of Box C. See patent family annex.

* Special categories of cited documents :

"A" document defining the general state of the art which is not considered to be of particular relevance	"T" later document published after the international filing date or priority date and not in conflict with the application but cited to understand the principle or theory underlying the invention
"E" earlier application or patent but published on or after the international filing date	"X" document of particular relevance; the claimed invention cannot be considered novel or cannot be considered to involve an inventive step when the document is taken alone
"L" document which may throw doubts on priority claim(s) or which is cited to establish the publication date of another citation or other special reason (as specified)	"Y" document of particular relevance; the claimed invention cannot be considered to involve an inventive step when the document is combined with one or more other such documents, such combination being obvious to a person skilled in the art
"O" document referring to an oral disclosure, use, exhibition or other means	"&" document member of the same patent family
"P" document published prior to the international filing date but later than the priority date claimed	

Date of the actual completion of the international search 11 July 2019	Date of mailing of the international search report 23/07/2019
--	---

Name and mailing address of the ISA/ European Patent Office, P.B. 5818 Patentlaan 2 NL - 2280 HV Rijswijk Tel. (+31-70) 340-2040, Fax: (+31-70) 340-3016	Authorized officer Squeri, Michele
--	--

INTERNATIONAL SEARCH REPORT

Information on patent family members

International application No

PCT/IB2019/053108

Patent document cited in search report		Publication date	Patent family member(s)	Publication date
CN 107456353	A	12-12-2017	NONE	

JP 2002065802	A	05-03-2002	NONE	

CN 104887421	A	09-09-2015	NONE	

US 5277685	A	11-01-1994	NONE	

US 5362297	A	08-11-1994	NONE	

Abstract

A cooperation system between a wheelchair and exercisers, allows both a control of the wheelchair's positioning and a locking thereof in a position for the gym exercise, the whole easily controllable by the user, without external aid, and on this regard it comprises: at least a magnetic hooking plate (11), fastened with respect to the exerciser (1) with a predetermined spatial correlation; extensible magnetic means aboard a wheelchair (6), extending therefrom to said at least a hooking plate (11), by determining a mutual positioning between wheelchair (6) and exerciser (1), suitable to perform exercises; and means (13) for driving said extensible magnetic means aboard a wheelchair (6), which can be actuated by the wheelchair's user in seated position from an unlocking position to a locking position and vice versa.

摘要

一种轮椅和运动器械之间的协作系统，既可以控制轮椅的位置，也可以将其锁定在健身房锻炼的位置，整个过程可由用户轻松控制，无需外部帮助，在这方面，其至少包括：磁性钩板（11），以预定的空间相关性相对于运动器械（1）固定；轮椅(6)上的可伸缩磁性装置，通过确定轮椅(6)和运动器械(1)之间适合进行锻炼的相互定位，从轮椅(6)延伸到所述至少一个钩板(11)；以及用于驱动轮椅（6）上的所述可扩展磁性装置的装置（13），其可以由处于就座位置的轮椅使用者从解锁位置驱动至锁定位置，反之亦然。