

P. BACHER & F. DEMING.
Padlock.

No. 218,213.

Patented Aug. 5, 1879.

Fig. 1.

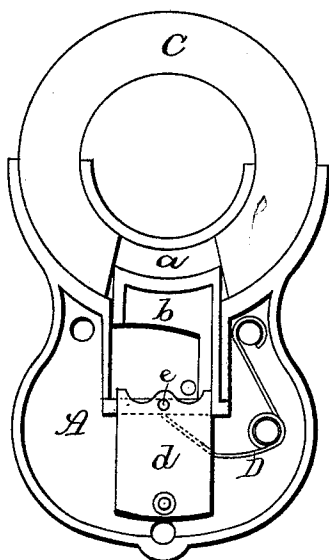
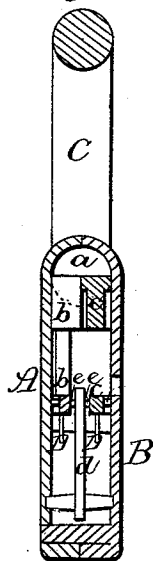

Fig. 2.



Witnesses:

J. W. Garner
W. S. D. Haines

Inventors:

Frank Deming,
Peter Bacher,
per
F. A. Lehmann, atty.

UNITED STATES PATENT OFFICE.

PETER BACHER AND FRANK DEMING, OF ALLEGHENY, PENNSYLVANIA.

IMPROVEMENT IN PADLOCKS.

Specification forming part of Letters Patent No. **218,213**, dated August 5, 1879; application filed June 21, 1879.

To all whom it may concern:

Be it known that we, PETER BACHER and FRANK DEMING, of Allegheny, in the county of Allegheny and State of Pennsylvania, have invented certain new and useful Improvements in Padlocks; and we do hereby declare the following to be a full, clear, and exact description of the invention, such as will enable others skilled in the art to which it pertains to make and use it, reference being had to the accompanying drawings, which form part of this specification.

Our invention relates to an improvement in padlocks; and it consists in the combination of a cut ring, two or more grooved tumblers which catch between the ends of the ring, a dividing-plate provided with guiding-lugs, and springs, as will be more fully described hereinafter.

The accompanying drawings represent our invention.

Figure 1 is a side elevation of our lock with one side removed. Fig. 2 is a vertical cross-section of the same.

The lock consists of two plates, A and B, both, when put together, forming the body of the lock. The upper parts of these plates are semicircular cavities *a*, for the reception of the movable ring C, from which ring a part is cut out sufficiently large to allow the passage of a staple for the attachment of the lock. The ring, when its open side is turned upward, releases the staple to which it may be attached, but when turned to conceal its opening in the body of the lock becomes fastened and held by turning the key.

Immediately under the center of the cavity *a* are two tumblers, *b c*, on top of one another, held in place by suitable guides on both plates A and B, having their upper ends arched in conformity with the cavities in which the ring C is held. The upper arched ends of these tumblers slide the one on the other; but their opposite lower ends are separated by a fixed plate, *d*, which also guides them when, by the key, the tumblers are moved.

Upon the upper end of the plate *d* there is made a lug, *e*, on each side, which lugs fit in small vertical grooves in the inner sides of the tumblers, so as to guide the tumblers in their movements when moved by the key. There are also guiding-flanges formed inside of the frame A B, which serve to assist in holding the tumblers in place.

The plate *d* is held at its lower end by two projecting pins, which enter corresponding recesses in the frame.

Although but two tumblers are here shown, it is evident that any desired number can be used.

The springs D have their ends applied to both under ends of the tumblers, under and above the plate *d*, and push them upward into the cut-away part of the ring, when the ring is placed in the proper position.

The tumblers move independently of each other, so that if by some means or other the upper one be pushed back in an attempt to pick the lock the lower one still holds the ring and prevents its being turned, without which the lock cannot be opened. To accomplish this both tumblers must be depressed simultaneously, which only can be done with the key made for the lock and introduced through the key-hole in the plate B.

Having thus described our invention, we claim—

In a padlock, the combination of a frame, A B, ring C, two or more grooved tumblers, *b c*, entering between the ends of said ring, springs D, and dividing-plate *d*, having the guiding lugs or projections *e*, substantially as shown.

In testimony that we claim the foregoing we have hereunto set our hands this 16th day of June, 1879.

PETER BACHER.
FRANK DEMING.

Witnesses:
A. M. IMBRIE,
DAVID DRANE.