

(No Model)

S. J. ADAMS.

TELEPHONE SUPPORTING DEVICE.

No. 414,132.

Patented Oct. 29, 1889.

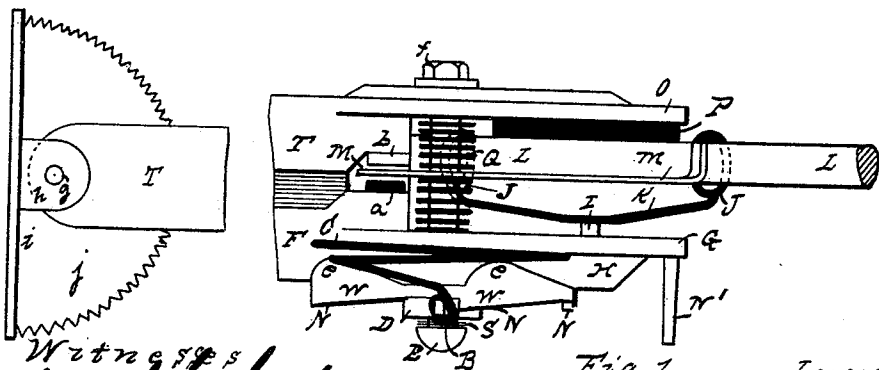
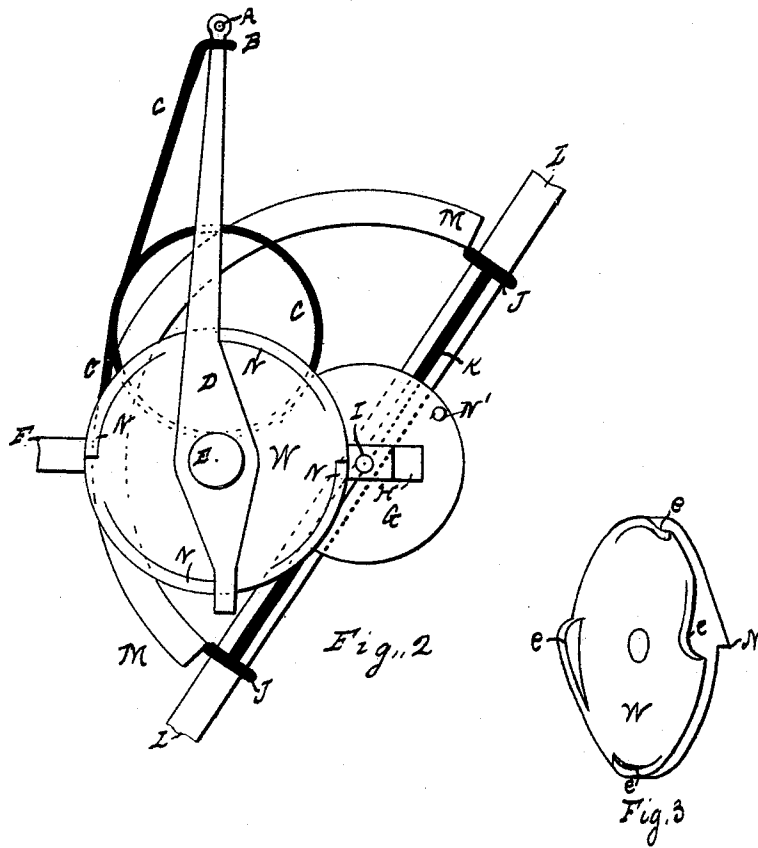

Witnesses  
*Adelaide A. Anderson*  
Adelaide A. Anderson

*Samuel J. Adams*  
Inventor

# UNITED STATES PATENT OFFICE.

SAMUEL J. ADAMS, OF DETROIT, MICHIGAN, ASSIGNOR OF THREE-FOURTHS  
TO JACOB BROWN AND ARTHUR BROWN, OF SAME PLACE.

## TELEPHONE-SUPPORTING DEVICE.

SPECIFICATION forming part of Letters Patent No. 414,132, dated October 29, 1889.

Application filed May 28, 1889. Serial No. 312,359. (No model.)

*To all whom it may concern:*

Be it known that I, SAMUEL J. ADAMS, of Detroit, in the county of Wayne and State of Michigan, have invented a new and useful  
5 Improvement in Telephone-Supporting Devices, of which the following is a specification.

My invention consists in an improvement in telephone-supporting devices relating to an improved mode of holding and locking the  
10 supporting-rod shown and described in Letters Patent No. 403,316, issued to me May 14, 1889.

Figure 1 is a plan view; Fig. 2, a side elevation, and Fig. 3 is an orthographic projection of the cam-disk.

T and F represent two arms corresponding, respectively, to the arms D and U, (shown in my patent alluded to,) formed at their ends into jaws O and G, corresponding to the jaws  
20 H and I of my former application.

P represents a disk, of rubber or other similar material, secured to the inner face of jaw O.

K represents a wire pivoted at the point I to the jaw G and ending in two rings J J, which loosely encircle the sliding rod L, which corresponds to the rod M of my former application.

M represents an arc of metal whose ends are secured to the rings J J, and at the point where said arc M passes between the jaws O and G said jaws are provided with a projection b and a piece of rubber a, or two projections or pieces of rubber, as desired, to clamp  
35 the arc M when the jaws are drawn together.

E represents a bolt which passes loosely through the two jaws O and G, having on one end a head and on the other end a screw-nut f.

Q represents a spiral spring surrounding  
40 the bolt E, whereby the jaws O and G are normally pressed apart.

H represents a projection formed on the outer surface of jaw G, and N' represents a stop-pin projecting from the outer surface of  
45 said jaw G.

W represents a disk having on one side a series of cams e, and on the other side a projecting series of notches N, and this disk W is secured on bolt E outside of the jaw G.

D represents a swinging lever fulcrumed on  
50 bolt E, and S represents a spiral spring be-

tween the head of said bolt and lever D, by which said lever D is forced against the outer surface of disk W. The lever D is formed to engage with one or two of the notches N when  
55 its upper end (marked A) is moved to the right, Fig. 2, and thereby rotates said disk W, while the resiliency of spring S enables the lever D to freely pass the notches N when moved in the contrary direction. The outer end of said  
60 lever is formed into a ring A, or other similar attachment for cord or chain by which the lever may be moved.

C represents a spring, one end of which is attached to the arm F, while the other end en-  
65 gages by means of a loop (marked B,) with the lever D and tends constantly to hold said lever in the position shown in Fig. 2.

The object of this invention is to avoid the necessity, which exists in the device shown in  
70 my patent, of fastening the cord which operates the locking-lever whenever it is desired to lock the apparatus, and its operation is as follows: When the rod L, carrying at its end the receiving-telephone, is adjusted to the  
75 position desired the lever D is pulled by a cord or chain connected with the ring A (and not shown in the drawings because it would hang down across the lever and disk) until said lever strikes against the stop-pin N' and its  
80 motion is thus arrested. In moving the lever D engages with one or more of the notches N on disk W, and rotates said disk so that one of the cams e engages with the projection H on jaw G, and thereby, acting through the  
85 bolt E, draws the jaws O and G together, clamping the rod L firmly between them, and also simultaneously clamping the arc M between the projections a and b. The cams e and the notches N are so arranged that when  
90 the lever D strikes the stop-pin N' the top of one of the cams e rests against the projection H on jaw G and locks the rod L between said jaws. The lever on being released returns to its normal position, through the action of  
95 spring C, being allowed to pass the notches N by the yielding of the spring S. When it is desired to release the rod L, a slight pull on the lever D carries the cam e beyond the projection H, and the jaws O G are separated by  
100 the action of spring Q. The plate i, carrying the lug h and serrated arc j, between which

the arm T is pivoted by the pin g, are the same as in my former application.

What I claim as my invention, and desire to secure by Letters Patent, is—

5 1. In a telephone-supporting device, the combination, with two jaws adapted to clamp a movable supporting-rod between them, of a rotatable disk carrying thereon a cam adapted to press the jaws together, a movable lever  
10 adapted to engage with the disk in one direction, and a spring adapted to hold said lever normally in one position, substantially as shown and described.

15 2. In a telephone-supporting device, the combination, with two jaws adapted to clamp a supporting-rod between them, of a rotatable disk carrying thereon a cam adapted to press

the jaws together, a movable lever adapted to engage with the disk in one direction, a spring adapted to hold said lever normally in one position, and a stop-pin secured to one of the jaws in the path of the lever, substantially as and for the purposes set forth.

3. The combination of the movable jaws O and G, the rod L, the pivoted support K, encircling said rod L at the end of said support, and the arc M, connected with said support and passing between the movable jaws, substantially as shown and described.

SAML. J. ADAMS.

Witnesses:

CYRUS E. LOTHROP,  
ADELAIDE A. ANDERSON.