

J. OLMSTED.

Keys for use with Electrical Apparatus.

No. 133,797.

Patented Dec. 10, 1872.

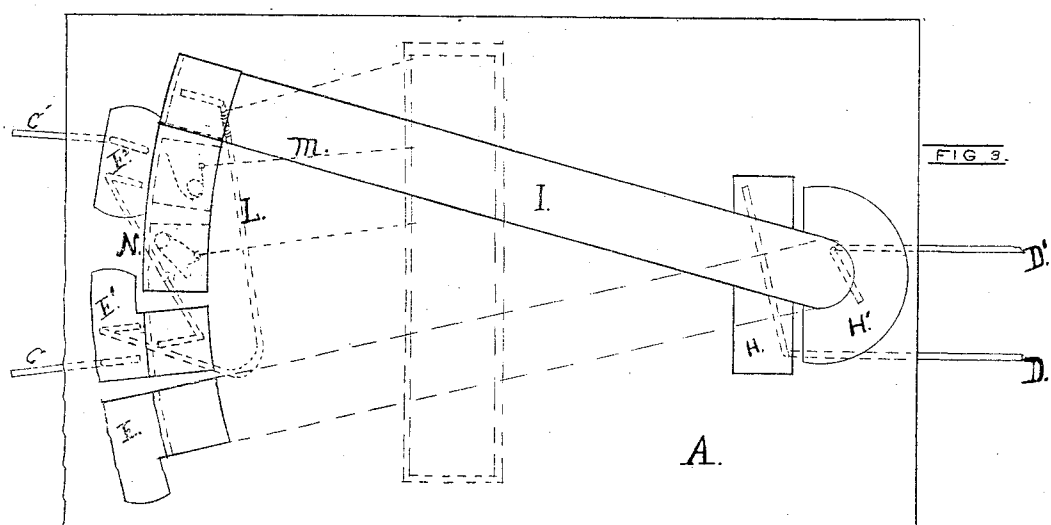
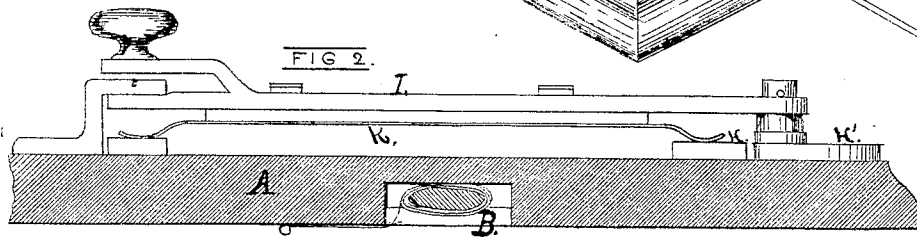
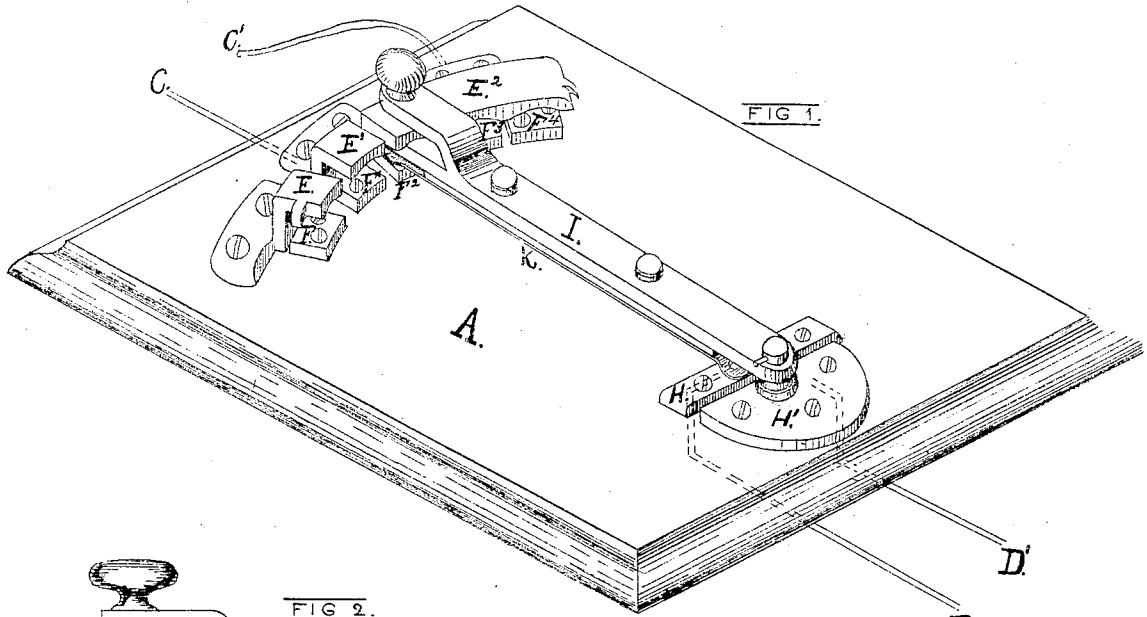

*Attorneys*  
Walter B. Hinckley  
Nathaniel S. Moore.

*Inventor*  
Joseph Olmsted

# UNITED STATES PATENT OFFICE.

JOSEPH OLMSTED, OF PROVIDENCE, RHODE ISLAND.

## IMPROVEMENT IN KEYS FOR USE WITH ELECTRICAL APPARATUS.

Specification forming part of Letters Patent No. **133,797**, dated December 10, 1872.

*To all whom it may concern:*

Be it known that I, JOSEPH OLMSTED, of the city and county of Providence, in the State of Rhode Island, have made certain new and useful Improvements in Key-Boards for Graduating the Power of Electro-Magnets; and I do hereby declare that the following specification, taken in connection with the drawing making a part of the same, is a full, clear, and exact description thereof.

Figure 1 is an isometrical view of my device. Fig. 2 is a section thereof. Fig. 3 is a top view.

The object of my invention is twofold: first, to graduate the electric current in such a manner as will place the amount of power used under the immediate control of the operator; second, to reverse the current for the purpose of demagnetizing the magnet and destroying the permanent magnetism, thus bringing the parts magnetized to their former neutral condition.

My invention is adapted to different mechanisms operated by an electric current, although it is more especially designed for the operation of what is generally known as the "electric car-brake."

I shall, therefore, for the sake of convenience and clearness, describe it in connection therewith.

In order to make the use of electricity practical in applying a car-brake, as well as for various other purposes, it first becomes important to graduate the current, for the reason that more power is required at some times than at others, it being well understood that the amount of power necessary is in proportion to the distance within which a train must be stopped, and that to use more power than is actually required is to produce unnecessary wear and strain.

In my invention the current may be divided into three parts, and one-third, two-thirds, or the whole used, as the distance or the necessities of the case may require.

In the drawing, Figures 1, 2, and 3, A is a small bed or table, having upon its under side a coil of resistance-wire, B. C and C' are wires connecting with the battery, and D and D' wires connecting with the brakes. The wires C and C' are connected with the conducting-pieces E E<sup>1</sup> E<sup>2</sup> and F F<sup>1</sup> F<sup>2</sup> F<sup>3</sup> F<sup>4</sup>;

the wires D and D' with the conducting-pieces H and H', the circuit being completed by the movable key I and the insulated spring K, the former connecting E E<sup>1</sup> E<sup>2</sup> with H', and the latter F F<sup>1</sup> F<sup>2</sup> F<sup>3</sup> F<sup>4</sup> with H. The movable end of the key I, when the current is broken, rests between E and F.

Commencing with the key I in this position, when the time arrives for applying the brakes the engineer moves it from right to left until it rests between E<sup>2</sup> and F<sup>2</sup>, as shown in Fig. 1. The circuit is now complete. The current flowing from the battery through the wire C', as shown in Fig. 1, is carried through the conducting-piece E<sup>2</sup>, the key I, conducting-piece H', and the wire D' to the brakes, and returning through the wire D, conducting-piece H, spring K, conducting-piece F<sup>2</sup> to the resistance wire B, from the resistance-wire B to the wire L, and from the wire L through the conducting-piece E<sup>1</sup> to the wire C, and back to the battery. The current thus flowing through the whole of the resistance-wire B develops its least power.

As soon, however, as it becomes necessary to set up the brakes with greater force, the engineer moves the key until it rests between E<sup>2</sup> and F<sup>3</sup>. The current now flows in the same manner, as before described, until, upon its return, it reaches the spring K, when it is conducted through the piece F<sup>3</sup> and a small wire, M, to the middle of the resistance-wire, B, from whence it passes back to the battery the same as before, and, as the current only flows through one-half of the resistance-wire, a greater amount of power is brought into use than in the first instance.

If, upon nearing a station, or otherwise, a sudden stop is necessary, the engineer slides the key in the same direction until it rests between E<sup>2</sup> and F<sup>4</sup>. The current now flows in the same manner, as at first described, until, upon its return, as before mentioned, it reaches the spring K, when it passes directly through the conducting-piece F<sup>4</sup> to the wire L, and thence to the battery, without passing through any of the resistance-wire, thus carrying to the brakes a full undiminished current.

The train now being stationary, it becomes necessary to throw off the brakes. As the armature comes directly in contact the mere breaking of the current would be insufficient

to throw off the brakes, inasmuch as the permanent magnetism would cause them to cling for some considerable time. This difficulty I easily overcome by moving the key back to its original position, which brings it for an instant of time between the conducting-pieces E<sup>1</sup> and F<sup>1</sup>, thus producing a current in the opposite direction, which neutralizes the permanent magnetism, the current flowing through the wire C', conducting-piece E<sup>2</sup>, wire N, conducting-piece F<sup>1</sup>, spring K, conducting-piece H to the wire D, and returning upon the wire D' through the conducting-piece H', key I, conducting-piece E<sup>1</sup> to the wire C, thence to the battery.

What I claim as my invention, and desire to secure by Letters Patent, is—

1. The graduating-key I, in combination with the resistance-coil B, for the purpose of regulating the resistance, in the manner substantially as described.
2. The current-reverser operated by the key I, in the manner substantially as described.
3. A rheostat thrown in or out of the circuit by means of the key I, in the manner substantially as described.

JOSEPH OLMSTED.

Witnesses:

WALTER B. VINCENT,  
NATHANIEL L. MORGAN.