

Feb. 7, 1928.

1,658,307

F. T. SMALL

PUMPING APPARATUS

Filed Dec. 19, 1924

3 Sheets-Sheet 1

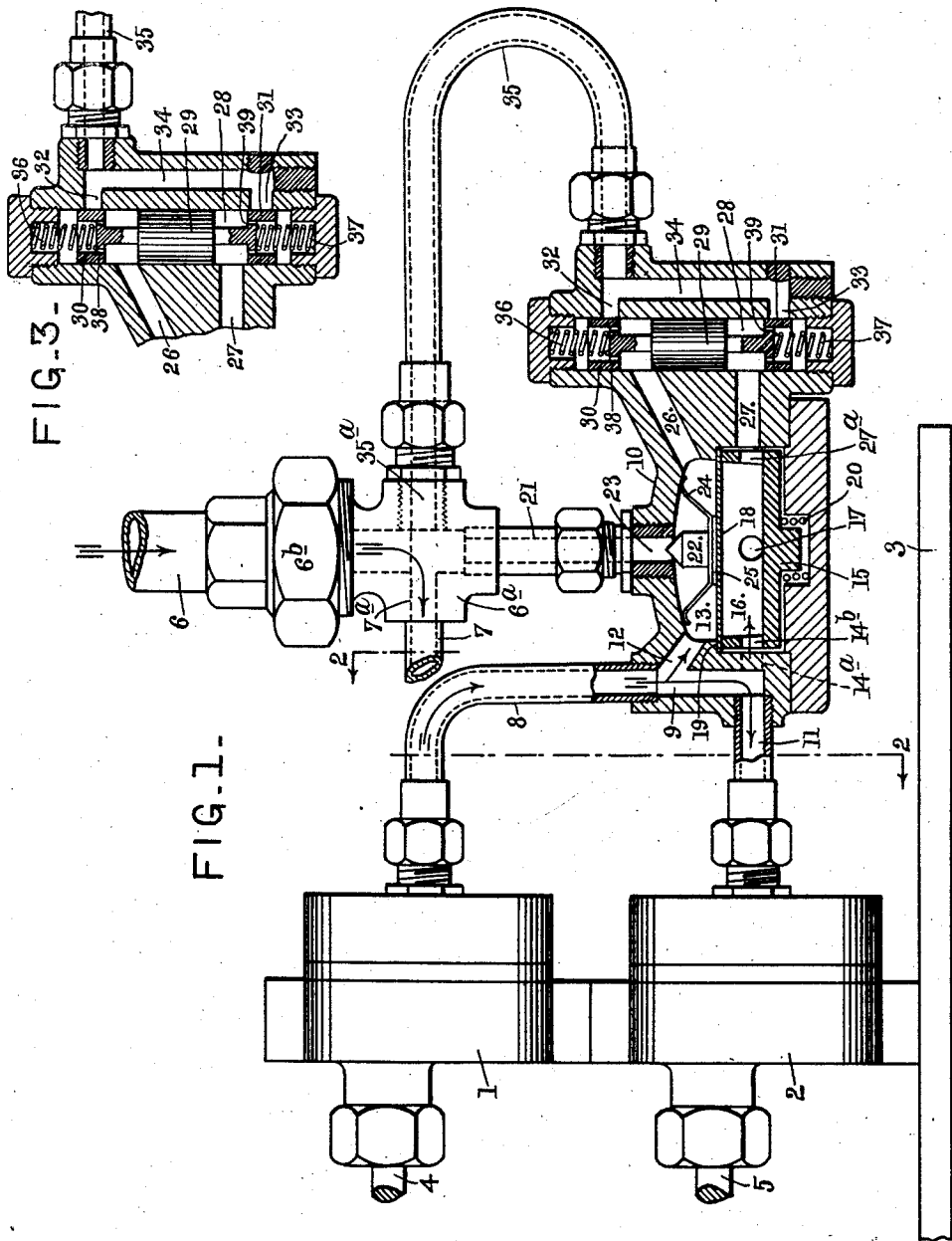

INVENTOR

FREDERICK T. SMALL,

By his Attorneys,
Baerlein & Wright

Feb. 7, 1928.

1,658,307

F. T. SMALL

PUMPING APPARATUS

Filed Dec. 19, 1924

3 Sheets-Sheet 2

FIG. 2.

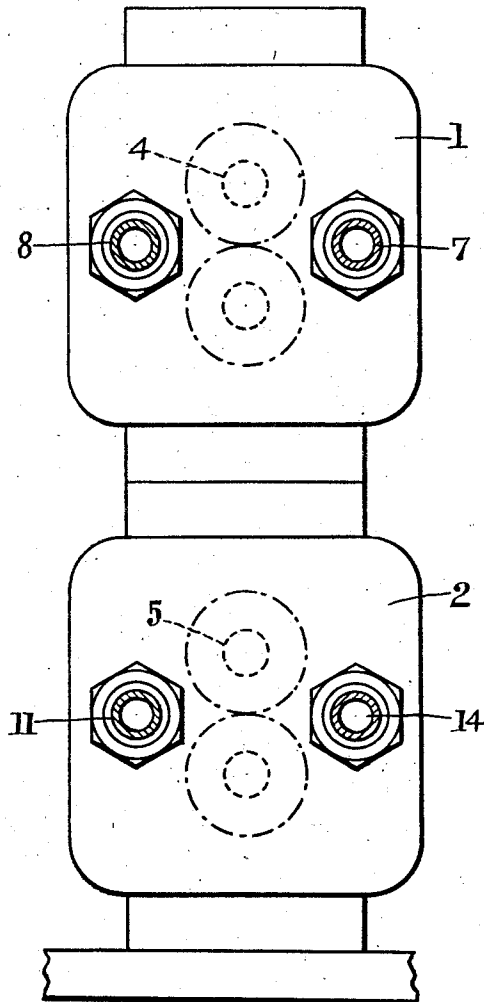

INVENTOR

FREDERICK T. SMALL,

By his Attorneys,

Paedon Wright

Feb. 7, 1928.

1,658,307

F. T. SMALL
PUMPING APPARATUS

Filed Dec. 19, 1924

3 Sheets-Sheet 3

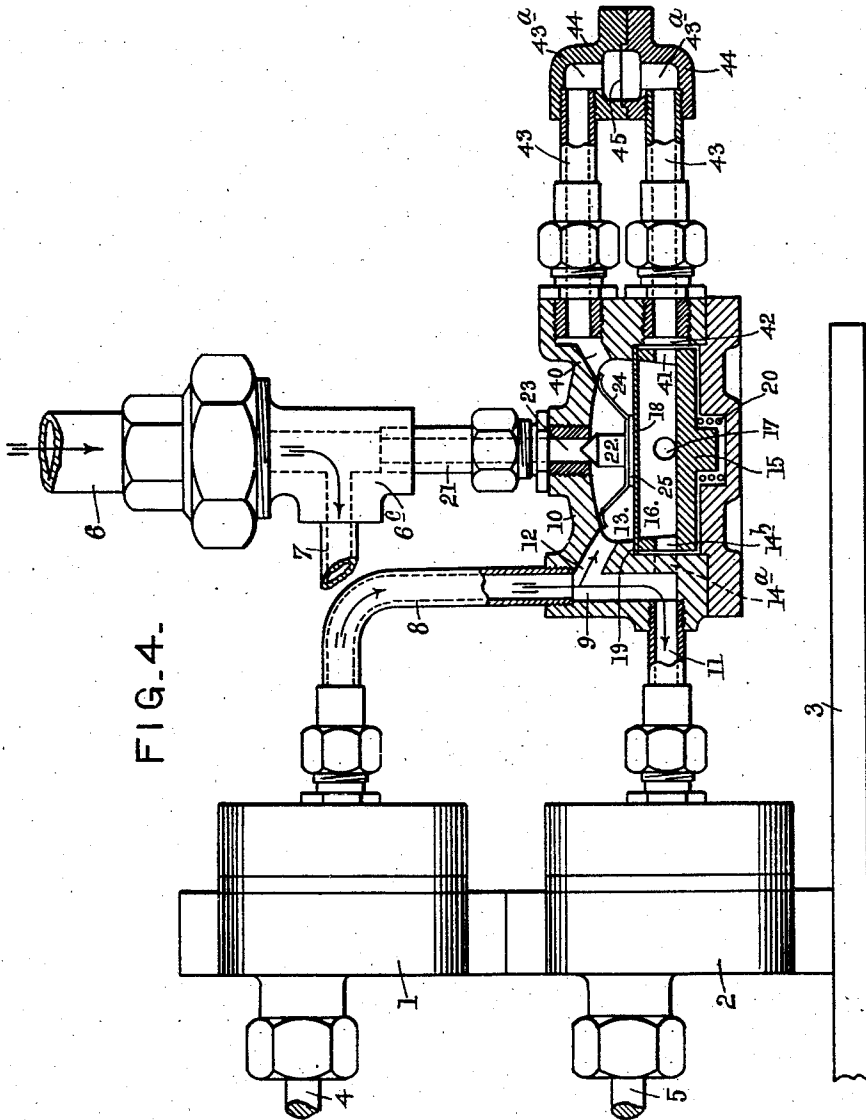

INVENTOR

FREDERICK T. SMALL,

By his Attorneys,

Baldwin & Wight

UNITED STATES PATENT OFFICE.

FREDERICK TROUTON SMALL, OF SPONDON, NEAR DERBY, ENGLAND, ASSIGNOR TO
CELANESE CORPORATION OF AMERICA, A CORPORATION OF DELAWARE.

PUMPING APPARATUS.

Application filed December 19, 1924, Serial No. 757,082, and in Great Britain January 22, 1924.

This invention relates to pumping units of the kind described in British patent specification 182,154 or 198,771, wherein two pumps of the gear wheel or other type are arranged in series, and are so constructed and operated that the delivery of the first pump (hereinafter called the pilot pump) is greater than that of the second pump (hereinafter called the measuring pump) which receives liquid therefrom and which is thus intended to act as a measuring device to pass the quantity of fluid required per unit of time. The surplus liquid from the pilot pump passes through a branch conduit or passage on the connection between the two pumps to one side of a diaphragm pressure balance valve, the other side of which is exposed to the pressure of the delivery pipe of the measuring pump, so that according to the pressure in the connection between the two pumps or that in the delivery from the measuring pump predominates, the diaphragm, by means of a needle or equivalent regulating device, acts to enlarge or reduce a by-pass opening through which excess liquid in the branch conduit or connection can escape back into the main supply to the pilot pump. With a view to keeping the pressure between the two pumps equal to that in the delivery pipe from the measuring pump and thus maintaining equal pressure on both sides of the measuring pump, so that if the delivery pressure from this pump varies, the diaphragm valve will automatically adjust the inlet pressure to the same degree.

In such pumping apparatus, which are employed in particular for supplying the spinning solution to the nozzles or jets of artificial silk spinning installations, the regulating diaphragm valve is usually arranged horizontally, and in the apparatus of the said British specification No. 198,771 the needle valve member which opens and closes the by-pass orifice under the action of the diaphragm, is inserted loosely or so as to float between the diaphragm and said orifice, usually with the interposition of a spring.

In the spinning of artificial silk, especially according to the dry-spinning or evaporative method, large numbers of such pumping units, comprising a pilot pump, a measuring pump and a pressure regulating diaphragm valve are employed to supply the spinnerets with spinning solution.

In practice with such pumping units it has been found that the unit is liable to become unbalanced, chiefly in consequence of failure of the pilot pump to develop all pressures it is called upon to balance in working, so that while the pressure balance of the unit may be satisfactorily maintained so long as the delivery pressure of the measuring pump does not rise above a certain limit, yet when this range is exceeded by the development of pressures on the delivery side of the measuring pump which are beyond the ability of the pilot pump to balance, the pressure balance of the unit and consequently the required regularity of delivery from the measuring pump, ceases to be maintained.

Unbalancing of the unit may also be caused by bad leakage past the needle valve or other by-pass controlling device.

The development of overlimit pressure in the measuring pump delivery may arise from various causes, for instance, in the case of spinning installations, from blocked spinneret orifices or other obstructions in the delivery. The result of such an unbalanced condition of the unit in the case of spinning installations is that the unit continues to spin under unbalanced conditions, thereby giving irregular denier of thread or filament. If the diaphragm bursts or breaks sufficiently to establish more or less free communication between the chambers of the pressure balance valve, the spinning solution can circulate idly in the unit and the delivery to the spinneret or spinnerets served by the unit ceases, so that the failure is observed, but if the diaphragm does not burst, the unit may easily continue to spin under the unbalanced conditions without this being observed. Broken diaphragms have of course to be replaced and as a large number of units are usually employed in an installation, this can be a matter of considerable expense for material and labour, but the other point, namely the liability of the unit to continue to spin under the unbalanced conditions, is the more serious.

In most cases as before mentioned, the unbalancing of the unit arises from development on the delivery side of the measuring pump of an increased pressure beyond the ability of the pilot pump to balance, the excess or unbalanced pressure then of course existing on the measuring pump side of the

diaphragm of the pressure balance valve. However in some cases unbalancing of the unit is caused by the development of an unbalanced excess of pressure on the other side, i. e. on the pilot pump and by-pass side of the pressure balance valve, due for instance to failure of the needle or like regulating device of this valve to function properly in opening the by-pass, more especially in cases where said needle or device is separate from the diaphragm and is provided with a spring as before mentioned, which may sometimes break or become weakened in course of time.

According to the present invention we employ an auxiliary device exposed on its opposite sides to the pressures existing on the respective sides of the diaphragm of the pressure balance valve. This auxiliary device is adapted to operate when a given excess or unbalanced pressure is developed in the delivery of the measuring pump as compared with the delivery pressure of the pilot pump, and thereby to make a passage between the delivery side of the measuring pump and some point or points in communication with the by-pass side of the diaphragm or the feed side of the pilot pump. Thus when the auxiliary device operates on the attainment of the given difference of pressure between the delivery of the measuring pump and that of the pilot pump, the pressure is released and the liquid can circulate idly in the unit, and the unit ceases to deliver the liquid to the spinning jet or jets or other point of use.

Said auxiliary release device may be in the form of a rupturable diaphragm adapted to break under the given pressure difference, or in the form of a piston valve, lifting disc, mushroom valve, ball valve, swing plate diaphragm valve or any other appropriate device.

The auxiliary release device may further be adapted also to operate and effect the release of an unbalanced excess of pressure on the other side of the diaphragm of the pressure balance valve, viz, the pilot pump and by-pass side of the pressure balance valve, and, thereby establish communication with the feed side of the pilot pump, thus permitting the liquid to circulate idly in the unit.

As one example, designed to operate under the action of excess or overlimit pressure on either side of the diaphragm of the pressure balance valve, a piston or like device exposed on its opposite faces to the pressure in upper and lower ports or passages opening respectively from the two chambers of the pressure balance valve is adapted, by means of piston valve extensions or members which it carries on its respective faces, to control the respective ends of a communication port between said upper and

lower ports and a pipe or branch communicating with the feed side of the pilot pump and therefore with the by-pass side of the diaphragm pressure balance valve. In normal working, the piston valve extensions close the ends of the said communication port, but when a given difference of pressure on the delivery side of the measuring pump is exceeded, the piston moves upwards under the excess. The upper piston valve extension is adapted in this movement to open connection between the upper end of the communication port and the upper port leading from the upper chamber of the diaphragm valve, a fraction before the lower piston valve extension makes communication between the port from the lower chamber of the pressure balance valve and the lower end of the communication port; this increases the out-of-balance condition and allows the piston to travel upwards to the full extent, thereby opening the bottom of the communication port and allowing all the fluid to be released from the delivery side of the measuring pump through the communication port to the pipe or branch communicating with the feed side of the pilot pump and it may be also by way of the upper port to the upper chamber of the diaphragm valve and thence to the feed side of the pilot pump. However the arrangement may be such that the pressure below the diaphragm is still sufficient to keep the by-pass closed thereby, so that the release takes place solely through the said pipe or branch communicating with the feed side of the pilot pump. When the pressure is released, the fluid can circulate idly in the unit and the delivery from the spinning jet or jets served by the unit ceases. Conversely, if an overlimit pressure difference is developed in the upper diaphragm chamber, due, for example, to jamming of the valve in the by-pass, the lower piston valve extension is adapted in a similar manner to open the connection between the lower end of the communication port and the lower port leading from the lower chamber of the diaphragm valve a fraction before the upper piston valve extension makes communication between the port from the upper chamber of the pressure balance valve and the upper end of the communication port. This increases the out-of-balance condition and allows the piston to travel downwards to the full extent, thereby opening the top of the communication port freely, and allowing all the fluid to be released from the upper diaphragm chamber through the communication port to the pipe or branch communicating with the feed side of the pilot pump. As before mentioned, an excess pressure is seldom developed on the upper or by-pass side of the diaphragm, unless the needle or regulating device thereof fails to act, for instance by reason of breakage or weakening

of the spring with which it is often provided. In this case in the example described, the pressure on the by-pass side of the diaphragm is discharged through the branch to the feed side of the pilot pump as explained. It may however be desired that in such a case the diaphragm of the pressure balance valve shall burst, and with this object, in another example, the piston valve device is so constructed and arranged that as it moves down under the over pressure, its lower extension releases the fluid from the lower port on the measuring pump delivery side of the pressure balance valve to the communication port and thence to the pipe or branch communicating with the feed side of the pilot pump, but at the same time the upper piston valve extension keeps the upper end of the communication port sealed from the upper port of the upper chamber of the pressure balance valve, thus enabling a high pressure to develop in this chamber until the diaphragm is broken. The over-pressures at which the piston valve operates in either of the examples just described may be arranged or determined by means of upper and lower springs which may be adapted to return the piston to the normal or neutral position when the cause of the out-of-balance condition is removed or this condition ceases to obtain.

As another example of the invention, a rupturable diaphragm or equivalent device may be fitted between two ports, passages or tubes in communication respectively with the two chambers of the diaphragm balance valve on the respective sides of the diaphragm, so that when said device breaks or moves under the given pressure difference it establishes communication between the respective chambers of the balance valve by way of these two ports, passages or tubes. This example is intended to operate in cases where overlimit pressure develops on the delivery side of the measuring pump.

It is to be understood that the foregoing examples are only given by way of illustration and can be varied widely.

Further it is understood that the invention may be applied in connection with pump units of the character referred to used for other applications than the pumping of spinning solutions.

The accompanying drawings illustrate three forms of pumping unit according to the invention for supplying artificial silk spinning solution to spinning jets, it being understood that these are given by way of example and can be varied widely without departing from the invention.

Fig. 1 is a sectional elevation of one form of pumping unit having an auxiliary pressure release arrangement adapted to release overlimit pressure from the delivery side of the measuring pump but to permit the

diaphragm of the pressure balance valve to be burst by pressure on the other side. The figure shows the diaphragm pressure balance valve and auxiliary release device in section. Fig. 2 is a section on line 2—2 Fig. 1 looking to the left and showing the connections of the pilot and measuring pumps in the system.

Fig. 3 is a sectional detail view of a form of pressure release valve according to another modification, adapted to release overlimit pressure on either side, i. e. from the delivery side of the measuring pump or from the by-pass side, the arrangement of the unit being otherwise similar to Figs. 1 and 2.

Fig. 4 is a sectional elevation of a form of the pumping unit according to a form of the invention in which a rupturable diaphragm is disposed to break under an overlimit pressure developed on the delivery side of the measuring pump and establish communication between the respective chambers of the balance valve and the feed side of the pilot pump.

Referring to Figs. 1 and 2, 1 is the pilot pump and 2 the measuring pump mounted together on a support 3 and having their spindles 4, 5 driven in the known way by chain or other gear. 6 is the supply pipe or header for the spinning solution to the unit. 7 is the feed pipe leading from the supply pipe 6 to the pilot pump 1, the pipe 7 being connected to the supply pipe 6 by one of the branches 7^a of a coupling piece 6^a secured to the supply pipe 6 by a union 6^b. 8 is the delivery pipe from the pilot pump 1 and forming, with the passage 9 in the diaphragm valve casing 10 and the pipe 11, the connection between the pilot pump and the intake side of the measuring pump 2. 12 is a passage in the diaphragm valve casing 10 and forming the branch conduit between the connection 8, 9, 11 and the upper balance valve chamber 13 on the by-pass side of the diaphragm, whilst 14 (Fig. 2) is the delivery pipe from the measuring pump 2, this pipe communicating with the lower chamber 16 of the diaphragm valve through a passage 14^a in the wall of the valve casing 10 and through an aperture 14^b in the cup-shaped spring mounted member 15 that forms said lower chamber 16 on the measuring pump delivery side of the diaphragm. 17 is the outlet from this chamber 16, leading to the spinning jet or jets supplied by the unit. 18 is the diaphragm of the pressure balance valve, held up against the shoulder 19 of the valve casing 10 by the spring 20 of the member 15. 21 is the by-pass pipe leading from the upper valve chamber 13 to the supply side of the pilot pump 1 by way of the passage 7^a in the coupling piece 6^a to which it is connected and the feed pipe 7. 22 is a needle

valve inserted loose or independent between the diaphragm 18 and the orifice 23 of the by-pass 21, with interposition of a spring 24 between the top of the chamber 13 and the base 25 of the needle valve as described in the said British specification No. 198,771.

A port 26 in the valve casing 10 opens out of the upper diaphragm valve chamber 13, and a port 27 in the casing 10 is in connection with the lower diaphragm valve chamber 16 by an aperture 27^a in the member 15.

These ports lead into a valve chamber 28 in which works a piston valve 29 having upper and lower valve extensions 30, 31 arranged to control the respective ends 32, 33 of a release port 34 in the casing 10, this port being connected to a branch pipe 35 which is connected to the passage 35^a of the connecting piece 6^a and thus communicates with the feed side of the pilot pump by way of the feed pipe 7 and also with the by-pass pipe 21. Springs 36, 37 are fitted between the valve extensions 30, 31 and the ends of the valve chamber 28 and small holes 38 and 39 are provided in the valve extensions 30, 31 respectively. In normal working the springs 36, 37 keep the valve in an intermediate position in which the ends 32, 33 of the release port 34 are closed, as seen in Fig. 1, but when a given overlimit pressure on the delivery side of the measuring pump relatively to the pressure on the by-pass side is exceeded the piston valve 29 moves up with its extensions 30, 31 under the effect of the pressure exerted through the port 27 on its lower face.

In this movement the upper valve extension 30 is adapted by its construction to open connection between the port 26 on the by-pass side and the end 32 of the release port 34 a fraction before the lower valve extension 31 makes communication between the lower port 27 and the lower end 33 of the release port 34; this increases the out-of-balance condition and allows the valve to shoot up, thereby opening the lower end 33 of the release port 34 by the lower valve extension 31 and allowing the solution to be released from the delivery side of the measuring pump through the holes 39 in the valve extension 31 and the port 34 to the branch pipe 35 and the feed side of the pilot pump. The solution will then circulate idly in the unit and the delivery from the spinning jet or jets served by the unit ceases until the cause of the out-of-balance condition is obviated or removed. The restoration of the piston valve to its neutral position may be accomplished by obviating the cause of the out-of-balance condition and removing the pressure from both diaphragm chambers in any way, e. g. by stopping the pumps.

In the converse and less usual case of an overlimit positive pressure difference being

developed on the by-pass side of the diaphragm, due for example to jamming of the valve 22 in the by-pass orifice, the piston valve 29 moves down under the action of the overlimit pressure exerted through the port 26, and the lower valve extension 31 uncovers the lower end 33 of the release port 34 and thus puts this in communication with the lower diaphragm chamber 16 and port 27. In the present example the arrangement is such as to permit the diaphragm to burst under the development of such an overlimit pressure on the by-pass side of the diaphragm, and for this purpose in the construction shown in Fig. 1, the upper valve extension 30 is of such length that when the piston valve has moved down under the overlimit pressure and put ports 27 and 34 into communication, the upper valve extension still seals the end 32 of the release port 34 thus enabling high pressure to develop in the diaphragm chamber 13 until the diaphragm is broken.

In the present example the holes 38 in the valve extension 30 serve to allow of the escape of any solution that may get behind this valve extension.

Referring now to the form or modification illustrated by Fig. 3, the arrangement of the pumping unit is the same as shown in Figs. 1 and 2, and similar numerals in Fig. 3 indicate corresponding parts to those in Fig. 1, but in this example the auxiliary release device is adapted to effect the release of an excess overlimit pressure difference exerted in either direction, i. e. whether on the delivery side of the measuring pump or on the by-pass side, and without bursting the diaphragm in the latter case as in the example last described.

Referring to Fig. 3, it will be seen that while the parts are otherwise the same as in Fig. 1, the upper valve extension 30 is of such a length that in the downward movement of the piston valve under the action of an overlimit pressure developed on the by-pass side of the diaphragm, the upper valve extension 30 does not keep the upper end 32 of the release port 34 sealed from the upper port 26, but permits the release of the pressure from the upper diaphragm chamber to the release port 34 and the feed side of the pilot pump in a similar manner to that in which the lower extension functions to release pressure from the delivery side of the measuring pump when overlimit pressure develops on this side. In normal working with this example the springs 36, 37 keep the piston valve 29 in an intermediate position in which the ends 32, 33 of the release port 34 are closed, as in the figure. When a given overlimit positive pressure difference on the delivery side of the measuring pump is exceeded the piston valve moves up under the pressure exerted through the port 27 and

the valve functions as in Fig. 1 the upper valve extension 30 opening connection between port 26 on the by-pass side and the end 32 of the release port 34 a fraction before the lower valve extension 31 makes communication between the lower port 27 and the lower end 33 of the release port 34, thus increasing the out-of-balance condition and allowing the valve to shoot up and open the lower end of the release port by the lower valve extension 31 whereupon the solution is released from the delivery side of the measuring pump through the holes 39 in valve extension 31, and the port 34 to the branch pipe 35 and the feed side of the pilot pump as in Fig. 1. Conversely, when an overlimit positive pressure difference is developed in the upper diaphragm chamber 13, the piston valve 29 moves downwardly under the pressure exerted through the port 26; the lower valve extension 31 now opens connection between the end 33 of release port 34 and the lower port 27 in connection with the lower diaphragm chamber a fraction before the upper piston valve extension 30 makes communication between the upper end 32 of the release port and the port 26 from the upper diaphragm chamber 13; the out-of-balance condition is thus increased and allows the piston to shoot down. Communication is now established between the port 26 and the end 32 of the release port through the holes 38 of the upper valve extension 30 and the fluid is released from the upper diaphragm chamber to the branch pipe 35 and the feed side of the pilot pump. It will be seen that the auxiliary release valve device thus functions in an identical manner in either direction. In either case when the pressure is released by the release valve through the pipe 35 the delivery of the solution to the spinning jet or jets served by the unit ceases until the cause of the out-of-balance condition is obviated or removed. The restoration of the piston valve to its neutral position may be accomplished as before mentioned.

Referring now to the example shown in Fig. 4, the pilot and measuring pumps 1, 2 are mounted as before, the supply pipe 6 being connected to the feed side of the pilot pump 1 by a pipe 7 and the delivery pipe 8 from the pilot pump 1 forms with a passage 9 in the diaphragm valve casing 10 and a pipe 11 the connection between the pilot pump and the intake side of the measuring pump 2, while a passage 12 in the casing 10 forms the branch conduit between the connection 8, 9, 11 and the upper diaphragm valve chamber 13 as before and the delivery pipe 14 (Fig. 2) from the measuring pump 2 likewise communicates with the lower diaphragm chamber 16 by a passage 14^a in the casing 10 and an aperture 14^b in the cup-shaped member 15 formed with the outlet 17

to the spinning jet or jets. The diaphragm 18 and needle valve 22 are constructed and arranged as before. A passage 40 leads from the upper diaphragm chamber 13 similarly to the port 26 in the previous examples while an aperture 41 in the member 15, similar to aperture 27^a in Fig. 1, communicates with a passage 42 in the casing 10. In the present example the by-pass pipe 21 is connected to the feed pipe 7 of the pilot pump and to the solution supply pipe 6 by a coupling piece 6^c, and the passages 40 and 42 are connected respectively to the inner ends of pipes 43, the outer ends of which connect with the chambers 43^a of a divided elbow connection 44 between the halves of which is clamped a rupturable diaphragm 45 which divides the interior of the elbow connection into the chambers 43^a. When a positive overlimit pressure difference is developed on the delivery side of the measuring pump the rupturable diaphragm can burst under this pressure exerted in the lower diaphragm chamber 16 and release the pressure through the upper diaphragm chamber 13, by-pass pipe 21 and feed pipe 7 to the feed side of the pilot pump, so that the solution will circulate idly in the unit and the delivery to the jet or jets ceases.

It will be understood that we do not limit ourselves to the particular forms of auxiliary pressure release devices shown in the examples described and illustrated, and that other appropriate release valves or devices may be employed.

What I claim and desire to secure by Letters Patent is:

1. In pumping units of the kind hereinbefore referred to for delivering artificial silk spinning solutions to spinning jets or other applications, the combination with the pilot and measuring pumps and diaphragm pressure balance valve, of an auxiliary device exposed on its opposite sides to the pressures on the respective sides of the diaphragm of the pressure balance valve and adapted to operate when an excess or unbalanced pressure is developed in the delivery of the measuring pump as compared with the delivery pressure of the pilot pump, and thereby to make a passage between the delivery side of the measuring pump and some point or points in communication with the feed side of the pilot pump or the by-pass side of the diaphragm, so that when the auxiliary device operates, the pressure is released and the liquid can circulate idly in the unit and the delivery from the unit to the spinning jet or jets or other point of use ceases.

2. A pumping unit according to claim 1 and characterized in that the auxiliary release device including means adapted also to effect the release of an unbalanced excess pressure on the other side of the dia-

phragm of the pressure balance valve i. e., the pilot pump and by-pass side of said valve, and thereby establish communication with the feed side of the pilot pump, thus permitting the liquid to circulate idly in the unit in this case also.

3. A pumping unit according to claim 1 characterized by a piston valve or like device exposed on its opposite faces to the pressure in upper and lower ports or passages opening from the respective chambers of the pressure balance valve, said piston valve or device having extensions or members adapted to control the respective ends of a pressure release port connected with a pipe or branch communicating with the feed side of the pilot pump, and by its movement under the effect of an excess unbalanced pressure on either side of the pressure balance valve to release the pressure from the corresponding side of the diaphragm through the pressure release port to the feed side of the pilot pump.

4. A pumping unit according to claim 1 characterized by a piston valve or like device exposed on its opposite faces to the pressure in upper and lower ports or passages opening from the respective chambers of the pressure balance valve, said piston valve or device having extensions or members adapted to control the respective ends of a pressure release port connected with a pipe or branch communicating with the feed side

of the pilot pump and by its movement under the effect of an excess unbalanced pressure on the measuring pump delivery side of the pressure balance valve to release the pressure from this side through said pressure release port, but in the converse movement under the action of an excess unbalanced pressure on the by-pass side of the pressure balance valve to release the fluid from the measuring pump delivery side of the pressure balance valve through the release port while keeping the other end of the release port sealed from communication with the other side of the diaphragm of the pressure balance valve, thereby permitting the diaphragm to be broken by development of pressure on this side.

5. In pumping units of the kind hereinbefore referred to for delivering artificial silk spinning solutions to spinning jets or other applications, the combination with the pilot and measuring pumps and diaphragm pressure balance valve, of an auxiliary device exposed on its opposite sides to the pressures on the respective sides of the diaphragm of the pressure balance valve and adapted to operate when an excess or unbalanced pressure is developed to permit idle circulation of the liquid in the unit and the cessation of the delivery of the same.

In testimony whereof I have hereunto subscribed my name.

FREDERICK TROUTON SMALL.