

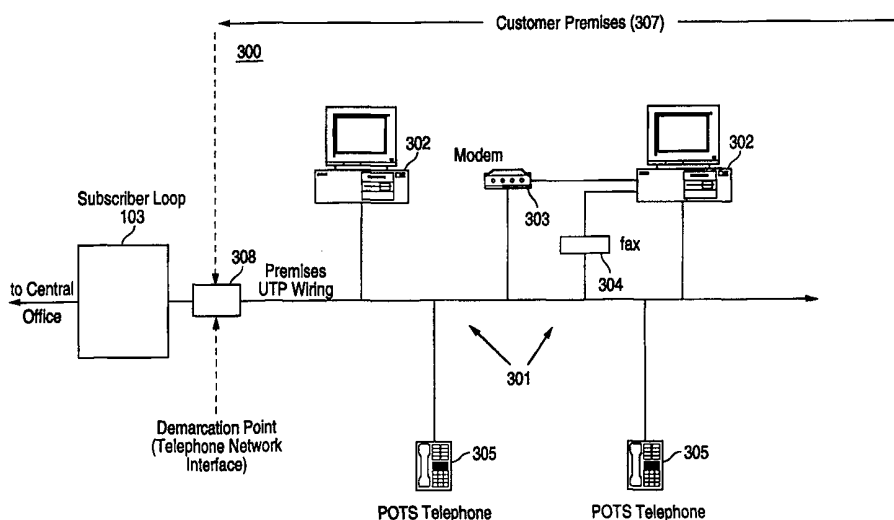

INTERNATIONAL APPLICATION PUBLISHED UNDER THE PATENT COOPERATION TREATY (PCT)

<p>(51) International Patent Classification ⁶ : H04L 12/66, 29/06, H04M 11/06, H04L 5/08</p>	<p>A1</p>	<p>(11) International Publication Number: WO 99/20022 (43) International Publication Date: 22 April 1999 (22.04.99)</p>
<p>(21) International Application Number: PCT/US98/20921 (22) International Filing Date: 8 October 1998 (08.10.98) (30) Priority Data: 08/948,687 10 October 1997 (10.10.97) US (71) Applicant: TRAVERTINE SYSTEMS, INC. [US/US]; 870 West Mause Avenue, Sunnyvale, CA 94086 (US). (72) Inventor: FOLEY, Peter, F.; 13124 Byrd Lane, Los Altos Hills, CA 94022 (US). (74) Agents: EDWARDS, Gary, J. et al.; Skjerven, Morrill, MacPherson, Franklin & Friel LLP, Suite 700, 25 Metro Drive, San Jose, CA 95110 (US).</p>		<p>(81) Designated States: AL, AM, AT, AU, AZ, BA, BB, BG, BR, BY, CA, CH, CN, CU, CZ, DE, DK, EE, ES, FI, GB, GE, GH, GM, HU, ID, IL, IS, JP, KE, KG, KP, KR, KZ, LC, LK, LR, LS, LT, LU, LV, MD, MG, MK, MN, MW, MX, NO, NZ, PL, PT, RO, RU, SD, SE, SG, SI, SK, SL, TJ, TM, TR, TT, UA, UG, UZ, VN, YU, ZW, ARIPO patent (GH, GM, KE, LS, MW, SD, SZ, UG, ZW), Eurasian patent (AM, AZ, BY, KG, KZ, MD, RU, TJ, TM), European patent (AT, BE, CH, CY, DE, DK, ES, FI, FR, GB, GR, IE, IT, LU, MC, NL, PT, SE), OAPI patent (BF, BJ, CF, CG, CI, CM, GA, GN, GW, ML, MR, NE, SN, TD, TG).</p> <p>Published <i>With international search report. Before the expiration of the time limit for amending the claims and to be republished in the event of the receipt of amendments.</i></p>

(54) Title: VIRTUAL GATEWAY SYSTEM AND METHOD



(57) Abstract

Existing (already installed) plain old telephone service (POTS) wiring at a customer premises is used as the wiring infrastructure for a local area network and additionally continues to provide ordinary POTS services at the customer premises. The network signals associated with the local area network and the POTS signals delivering POTS services coexist on the POTS wiring at the customer premises using frequency division multiplexing. In addition to POTS service, the subscriber loop also provides access to xDSL (digital subscriber line) signals associated with a wide area network (WAN). Thus three distinct networks (the PSTN associated with POTS, xDSL and the LAN) coexist on a single wiring infrastructure. A virtual gateway provides for communication between each of the distinct networks without breaking the electrical continuity of the POTS wiring at the customer premises and thus maintaining lifeline POTS services, without the installation of a new dedicated active (needing AC current) Gateway device, and without the need to pull new cable to implement the premises LAN.

FOR THE PURPOSES OF INFORMATION ONLY

Codes used to identify States party to the PCT on the front pages of pamphlets publishing international applications under the PCT.

AL	Albania	ES	Spain	LS	Lesotho	SI	Slovenia
AM	Armenia	FI	Finland	LT	Lithuania	SK	Slovakia
AT	Austria	FR	France	LU	Luxembourg	SN	Senegal
AU	Australia	GA	Gabon	LV	Latvia	SZ	Swaziland
AZ	Azerbaijan	GB	United Kingdom	MC	Monaco	TD	Chad
BA	Bosnia and Herzegovina	GE	Georgia	MD	Republic of Moldova	TG	Togo
BB	Barbados	GH	Ghana	MG	Madagascar	TJ	Tajikistan
BE	Belgium	GN	Guinea	MK	The former Yugoslav Republic of Macedonia	TM	Turkmenistan
BF	Burkina Faso	GR	Greece	ML	Mali	TR	Turkey
BG	Bulgaria	HU	Hungary	MN	Mongolia	TT	Trinidad and Tobago
BJ	Benin	IE	Ireland	MR	Mauritania	UA	Ukraine
BR	Brazil	IL	Israel	MW	Malawi	UG	Uganda
BY	Belarus	IS	Iceland	MX	Mexico	US	United States of America
CA	Canada	IT	Italy	NE	Niger	UZ	Uzbekistan
CF	Central African Republic	JP	Japan	NL	Netherlands	VN	Viet Nam
CG	Congo	KE	Kenya	NO	Norway	YU	Yugoslavia
CH	Switzerland	KG	Kyrgyzstan	NZ	New Zealand	ZW	Zimbabwe
CI	Côte d'Ivoire	KP	Democratic People's Republic of Korea	PL	Poland		
CM	Cameroon	KR	Republic of Korea	PT	Portugal		
CN	China	KZ	Kazakistan	RO	Romania		
CU	Cuba	LC	Saint Lucia	RU	Russian Federation		
CZ	Czech Republic	LI	Liechtenstein	SD	Sudan		
DE	Germany	LK	Sri Lanka	SE	Sweden		
DK	Denmark	LR	Liberia	SG	Singapore		
EE	Estonia						

VIRTUAL GATEWAY SYSTEM AND METHOD

BACKGROUND OF THE INVENTION5 1. Field of the Invention

This invention relates generally to computer network gateways and more particularly to computer network gateways that connect a local area network to one or more distinct networks sharing the same electrically contiguous communication channel.

10 2. Description of the Related Art

The expansion of the Internet and the world wide web, the prevalence of telecommuting, and the anticipation of video on demand has generated a demand for the delivery of digital information to customer premises at bandwidths higher than can be delivered using traditional voice-grade modem technology.

15 Various solutions to the high bandwidth delivery problem are under development. Unfortunately, many of these solutions require the installation of a new wiring or cabling infrastructure to deliver information to a customer premises. One class of technology that does not have this drawback is digital subscriber line (xDSL) technology. Digital subscriber line technology has the advantage that it
20 uses the existing subscriber line (local loop) infrastructure to deliver a higher bandwidth signal to a customer premises. This means that it uses the existing unshielded twisted pair (UTP) copper wiring that connects to a customer premises (subscriber premises).

The preferred xDSL technology, Asymmetric Digital Subscriber Line
25 (ADSL), achieves the delivery of higher bandwidth by installing ADSL modems at both ends of the subscriber loop (e.g., at the telephone central office and at the customer premises). ADSL signals are then transmitted between the ADSL modem at the central office (ATU-C), and premises ADSL modem (ATU-R) over the existing UTP subscriber loop wiring.

Figure 1 illustrates the spectral allocation 100 on an asymmetrical digital subscriber line (ADSL). The baseband portion of the spectrum is allocated for POTS connections 101 and the portion from 25KI-Iz to 1.1Mhz is allocated for ADSL signals 102. ADSL signals 102 provide access to wide area computer networks and the POTS connections provide access to the public switched telephone network (PSTN).

Many customer premises provide xDSL access to more than one computer at a premises. Conventionally, this multiple access is provided using a 10baseT LAN to connect multiple computers to an xDSL modem/hub. The xDSL modem/hub performs xDSL modem functions and additionally may perform gateway (networking bridging) functions to facilitate communication between the premises LAN and the WAN made accessible via xDSL technology.

Figure 2 illustrates a conventional xDSL system that provides multiple computers 201 with access to a wide area network (WAN) 202 via xDSL. The exemplary xDSL system uses asymmetrical digital subscriber loop (ADSL) technology. The system includes a conventional ADSL modem/hub 203 that operates as a network hub (e.g., a 10/100baseT Ethernet hub) for local area network 205. LAN 205, also known as the Premises Distribution Network is a point to point LAN having a star configuration centered around the hub portion of ADSL modem/hub 203. Installing LAN 105 involves the installation of a wiring network that supports 10/100baseT Ethernet. This means that new wiring or cabling must be "pulled" for each computer 201 to be included in LAN 205

ADSL modem/hub 203 is coupled to a telephone central office 207 via a subscriber loop. ADSL modem/hub 203 includes a POTS splitter 213 that may couple plain old telephone service signals to the exiting (installed) plain old telephone service (POTS) UTP wiring (POTS wiring) 206 at the customer premises 204.

In operation, a conventional ADSL modem 208 (ATU-C) located at central office 207 receives digital signals from a wide area network 202, modulates the received signals and then places them on the UTP subscriber loop using a POTS

splitter at the central office. This POTS splitter combines ADSL signals and POTS signals for transmission to the premises and conversely splits POTS and ADSL signals upon reception from the premises.

Preferably, ADSL modem/hub 203 is located at the telephone Network Interface (TNI) 110 at the demarcation point between the subscriber loop and the customer premises so that the output of the POTS splitter 213 is coupled to the premises UTP wiring before any branching occurs and before the installation of any RJ-11 jacks. The subscriber loop is thus terminated at the ADSL modem/hub, which is an active device requiring AC power. Locating POTS splitter 213 elsewhere at a customer premises requires knowledge of the customer premises wiring topology and the willingness to electrically "break" the wiring at the splitter insertion point in order to insert the active device (e.g., the ADSL modem/hub 203). Without a clear understanding of the customer premises wiring topology, it is difficult to know which part of the premises wiring will carry both ADSL and POTS signals as opposed to only POTS signals. Most typically, the POTS splitter is integral with the ADSL modem/hub (as shown in Figure 1) therefore, it is preferred to install the ADSL modem/hub 203 at or near the TNI 110. Placing on ADSL modem/hub 203 at the TNI 110, however, has certain drawbacks such as the need for an AC power source/outlet near the TNI and the risk of exposure to harsh environmental elements (e.g., temperature extremes, rain, etc.). Further, when the hub and the modem are combined, new wiring must be "pulled" to the TNI from computers 201 to complete network connections.

The above described system known in the art provides for communication between multiple device networks: a WAN, a LAN at a customer premises and the PSTN. This communication is enabled using an active device (e.g., an ADSL modem/hub) that breaks the electrical continuity between the subscriber loop and the premises LAN (Premises Distribution Network) with the installation of an active device, typically a hub, in order to provide hub/gateway functionality between the LAN and the WAN.

The above described system has several drawbacks. The system requires the installation of a new active device (the hub 203) that adds considerable cost and installation complexity. Further, installing new wiring for a LAN at the customer premises is complex and costly, and the LAN and the subscriber loop do not share the same electrically contiguous communications medium. The LAN wiring does not support DC current flow from the subscriber loop, which means POTS, and more particularly, POTS lifeline service, is not supported on the LAN wiring.

Thus, there is a need for an improved system and method for interconnecting distinct premises LAN and subscriber loop WAN device networks without the need for insertion of an active hub/gateway device between the premises POTS wiring and the subscriber loop, without the pulling of new cable to implement the premises LAN, and without breaking the electrical continuity (DC current capability) of the wiring - which would preclude POTS lifeline service.

15 SUMMARY OF THE INVENTION

In accordance with the present invention, there is provided a system and method for providing bi-directional communication between a first device network and a second device network using a shared electrically contiguous communication channel such as an existing (already installed) customer premises plain old telephone (POTS) wiring. Each device network is coupled to the shared electrically contiguous communication channel and each are further allocated separate spectral bands for use on the shared communication channel. Thus, two distinct device networks coexist on a single shared communication channel using frequency division multiplexing. Communication between the distinct device networks is perfected by converting signals from the spectral band associated with the source network to the spectral band(s) associated with the destination network.

The gateway server of the present invention is advantageously operatively coupled to the shared communication channel without breaking the electrical continuity of the shared communication channel. Because electrical continuity is

not broken, DC current may pass; and the customer premises wiring is capable of maintaining POTS lifeline services and POTS signaling protocols.

In a centralized architecture, the virtual gateway of the present invention includes first and second modems, each associated with one of the device
5 networks. It should be understood that as used herein, "modem" means a modulator-demodulator device or a transceiver and the like. Further, as used herein "modem" includes modems that effect direct current (DC) baseband signaling as well as bandpass and highpass signaling and the like. The modem associated with the first device network has a receive portion and a transmit portion
10 for converting signals from the spectral band associated with the first network to baseband and for converting baseband signals to the spectral band associated with the first network, respectively. Similarly, the modem associated with the second device network has a receive portion and a transmit portion for converting signals from the spectral band associated with the second network to baseband and for
15 converting baseband signals to the spectral band associated with the second network, respectively. The virtual gateway server additionally provides for communication of baseband data between the first and second modems using means conventionally found within a personal computer or similar computing device (such as a PCI bus, etc.). It should be understood that as used herein "
20 baseband" includes data not modulated by a carrier frequency, such as data processed by a microprocessor or transferred over a personal computer bus such as a PCI bus.

Information is sent from a sending network to a receiving network by first demodulating the information in accordance with the protocol and modulation
25 scheme associated with the sending network to generate baseband data. The baseband data is then processed to generate a band pass signal in accordance with the modulation scheme and protocol associated with the receiving network. The baseband processing includes any required protocol conversion to translate the data from the protocol associated with the sending network to the protocol associated
30 with the receiving network.

In accordance with another aspect of the invention, rather than locating the first and second modems centrally on a gateway server, the gateway functionality is distributed across a plurality of network clients. Thus, first and second modems, each associated with the first and second networks, respectively, are located at a plurality of network clients. Advantageously, this distribution of the gateway functionality reduces network traffic and improves overall system performance because the same data need not be transmitted on multiple spectral bands in order to be received by clients of either device network.

In accordance with another aspect of the invention, the virtual gateway functionality is partially distributed such that the modems located at the clients provide both transmit and receive capability in the spectral band associated with the first network but provide only receive capability in the spectral band associated with the second network. The transmit capability associated with the second network is not distributed but instead is centrally located at a server. This partially distributed architecture is particularly advantageous when the second network is characterized by asymmetrical data traffic patterns. For example, in cases where the second network is a wide area network supplying video on demand, the data traffic is highly asymmetrical. Advantageously, this partial distribution of the gateway functionality reduces network traffic and improves overall system performance because data transmitted on the second network need not be retransmitted in the spectral band of the first network to be received by clients of the first network.

The features and advantages described in the specification are not all-inclusive, and particularly, many additional features and advantages will be apparent to one of ordinary skill in the art in view of the drawings, specification, and claims hereof. Moreover, it should be noted that the language used in the specification has been principally selected for readability and instructional purposes, and may not have been selected to delineate or circumscribe the inventive subject matter, resort to the claims being necessary to determine such inventive subject matter.

BRIEF DESCRIPTION OF THE DRAWINGS

Figure 1 illustrates spectral allocation on a digital subscriber line.

Figure 2 illustrates a conventional local area network installed at a customer
5 premises.

Figure 3 illustrates a home area network (HAN) using installed POTS
wiring.

Figure 4A is an illustration of spectrum utilization on the POTS wiring
shown in Figure 3.

10 Figure 4B is an illustration of alternative spectrum utilization on the POTS
wiring shown in Figure 3.

Figure 5A is a functional block diagram of a network interface card (NIC)
included in a computer installed in the HAN shown in Figure 3.

15 Figure 5B is a functional block diagram of an external network peripheral
interface used to connect a computer to the HAN shown in Figure 3.

Figure 6 is a flow diagram of the receive-side processing steps performed
by the NICs shown in Figures 5A and 5B.

Figure 7 is a flow diagram of the transmit-side processing steps performed
by the NICs shown in Figures 5A and 5B.

20 Figure 8 shows a lowpass filter shown in the HAN illustrated in Figure 3.

Figure 9 shows diplexer filter which is alternatively used in place of the
lowpass filter shown in the HAN illustrated in Figure 3.

Figure 10 shows an alternative embodiment of a HAN using filters at
customer premises equipment in accordance with the present invention.

25 Figure 11 is a block diagram of the diplexer filters used to connect the
legacy POTS customer premises equipment to the HAN as shown in Figure 10.

Figure 12 is a frequency response graph illustrating the group delay
associated with a filter in accordance with the invention.

30 Figure 13 is a frequency response graph illustrating the group delay
associated with a filter in accordance with the invention.

Figure 14A is a functional block diagram of a customer premises having a centralized virtual gateway in accordance with the present invention.

Figure 14B is a functional block diagram of a network interface card used in the virtual gateway shown in Figure 14A.

5 Figure 15 is flow diagram of the virtual gateway method implemented by the centralized virtual gateway shown in Figure 14.

Figure 16 is a functional block diagram of a customer premises having a fully distributed virtual gateway in accordance with the present invention.

10 Figure 17 is a functional block diagram of a customer premises having a partially distributed virtual gateway in accordance with the present invention.

Figure 18 is a functional block diagram of a customer premises having two separate HANs operating on customer premises POTS wiring.

Figure 19 is an illustration of the spectral allocation of the customer premises wiring shown in Figure 18.

15

DESCRIPTION OF THE PREFERRED EMBODIMENT

Figures 3 - 19 depict a preferred embodiment of the present invention for purposes of illustration only. One skilled in the art will readily recognize from the following discussion that alternative embodiments of the structures and methods
20 illustrated herein may be employed without departing from the principles of the invention described herein.

The virtual gateway of the present invention provides an interconnection between two or more device networks that are each coupled to a shared communication channel. In a preferred embodiment, the virtual gateway
25 interconnects a home local area network (a HAN) to a POTS-accessed WAN and to an ADSL-accessed WAN. Further, in the preferred embodiment, the HAN wiring infrastructure leverages the existing (installed) customer premises wiring which is a shared communication channel common among the HAN, POTS service and ADSL service at a customer premises. To further understand the virtual
30 gateway of the present invention, a HAN is first described.

Figure 3 illustrates a home area network (HAN) 300 in accordance with the present invention. HAN 300 includes existing (installed) plain old telephone service (POTS) wiring 301, network clients 302, the computer port side of modem 303 and fax 304. POTS wiring 301 provides wiring infrastructure used to network
5 multiple network clients 302 at a customer premises 307.

POTS wiring 301 is conventional unshielded twisted pair (UTP) wiring that is generally routed internally in the walls of the customer premises 307 (e.g., a house) to various locations (e.g., rooms) within customer premises 307.

Subscriber loop 306 (also called a "local loop") is a physical wiring link
10 that directly connects an individual customer premises 307 to the central office. Subscriber loop 306 is unshielded twisted pair (UTP) wire. UTP wire causes signal attenuation over extended distances. This attenuation is greater for higher frequency signals. To accommodate the constraints imposed by the electrical properties of subscriber loop 306, subscriber loop 306 line lengths are generally
15 confined to a length no greater than 18 kilometers, although longer line lengths are sometimes used. Nonetheless, subscriber loop 306 is not well suited to transmit signals greater than 1.1 mhz.

Customer premises 307 is a subscriber premises that has arranged
(generally for a monthly telephone service fee or for a per calling minute fee) with
20 a local provider (such as a local telephone company) for a connection to a central office. A central office is a central telephone office (also called a local exchange) that provides local switching and non-local switching (via the Public Switched Telephone Network (PSTN)).

Network client 302 is personal computer equipped with a network interface
25 card (shown in Figure 5A). It should be understood, however, that the principles of the present invention apply to HANs including other types of network clients such as specific purpose computers, computer appliances, computer-enabled devices or other types of network devices.

In addition to providing connectivity among (e.g., networking) network
30 clients 302, POTS wiring 301 connects to conventional POTS-compatible POTS

on telecommunications devices (such as telephones 305, modem 303 and facsimile machine 304). POTS wiring 301 thus additionally couples telephone 305 and modem 303 to a central office via subscriber loop 306. The central office, in turn, connects the POTS-compatible devices to another POTS-compatible device located
5 off premises.

Advantageously, HAN 300 connects (networks) network clients 302 without disrupting ordinary telephone and telecommunications services including digital subscriber line (xDSL) services conventionally provided on POTS wiring 301. HAN 301 and conventional POTS services simultaneously utilize POTS
10 wiring 301 by frequency division multiplexing network related signals (HAN signals) and POTS signals to achieve spectral avoidance.

Figure 4A is an illustration of the utilization of spectrum 400 on POTS wiring 301 at a customer premises in accordance with the present invention. Spectrum 400 shows four separate frequency bands in which information is
15 communicated: a POTS band 401, an ADSL upstream band 402, an ADSL downstream band 403 and HAN band 404. POTS band 401 is baseband up to approximately 4KHz. Conventional POTS signals such as voice signals, modem signals and facsimile signals occupy the baseband region of the spectrum with a maximum bandwidth of 4KHz. ADSL upstream band 402 and ADSL downstream
20 band 403 both carry signals in accordance with asymmetrical digital subscriber line (ADSL) protocol. ADSL upstream band 402 occupies a band ranging from 25KHz to 1.1MHz and carries ADSL signals from a customer premises to a central office. ADSL downstream band 403 occupies a band ranging from 140KHz up to 1.1MHz and carries ADSL signal from a central office to a customer premises.
25 Instead of employing FDM to separate the upstream and downstream bands, the ADSL protocol allows upstream band 402 and downstream band 403 to overlap and share spectrum from 25KHz to 140KHz using echo cancellation. ADSL supports full-duplex communication. In accordance with ADSL protocol, the bandwidth allocated to downstream signals (downstream band 403) is greater than
30 the bandwidth allocated to the upstream channel (upstream band 402) band in order

to better accommodate models of information flow that anticipate a greater amount of data flowing into a customer premises rather than out of a customer premises.

HAN band 404 occupies the portion of the spectrum above 1.1MHz. Due to line lengths associated with subscriber loops and the resulting signal attenuation at frequencies above 1.1MHz, it is not practical to use this portion (the portion
5 above 1.1MHz) of the spectrum for communications between a central office and a customer premises. Line distances within a customer premises, however, are sufficiently short that signals above the 1.1MHz range are successfully transmitted and received within a customer premises. HAN 300 therefore, utilizes the portion
10 of spectrum above 1.1MHz thereby avoiding that portion of the spectrum utilized at the central office to send signals to a customer premises.

Figure 4B is an illustration of an alternative utilization of spectrum 410 on POTS wiring 301 in accordance with the invention. Spectrum 410 includes POTS band 401, ADSL upstream band 402, ADSL downstream band 403 and HAN band
15 411. HAN band 411 occupies the portion of the spectrum above 4MHz. Spectrum 410 thus includes spacing band 412. Spacing band 412 is a "dead band" that is not occupied by signal, other than any signal due to frequency bleeding from adjacent bands (e.g., from ADSL downstream band 403 or HAN band 411). Use of spacing band 412 eases filter implementation by: (i) eliminating the need for strict filter
20 characteristics; (ii) reducing the impact of group delay by allowing the placement of the filter cutoff frequency further up into the dead band; and (iii) providing a frequency band to transition between the highpass and lowpass sections of the diplex filters discussed below.

HAN 300 is a symmetric network. This means that data rates in the
25 transmit and receive directions can be the same. Further, HAN 300 provides a half duplex channel meaning that a single network client transmits at a time. Thus HAN bands 404, 411 accommodate both transmit and receive signals in a half duplex mode of operation.

Referring back again to Figure 3, each network client 302 is equipped with
30 an internally mounted HAN network interface card (NIC). Figure 5A is a

functional block diagram of a preferred network interface card (NIC) 500 in accordance with the present invention. NIC 500 includes RJ-11 jacks 501, analog front end (AFE) block 502, HAN modem ASIC 503, PCI connector 504 and digital video connector 505. RJ-11 jacks 501 are conventional POTS-compatible telephone jacks. Thus, NIC 500 (and hence network client 302) are coupled to HAN 300 in the same manner that conventional telephones are coupled to the central office, by simply plugging into an existing RJ-11 wall jack. AFE block 502 is an interface circuit that performs analog signal conditioning and provides electrical isolation and surge protection in compliance with the Code of Federal Regulations (C.F.R.) Part-68 for connection to the PSTN. In order to facilitate HAN connectivity to multiple POTS lines (e.g., multiple networks of POTS wiring 301) as is the case with a customer premises 306 equipped with two phone lines, AFE block 502 is equipped with two RJ-11 jacks 501. In the two-phone-line-architecture a single network is created by bridging the separate phone lines in the HAN spectral domain.

HAN modem ASIC 503 is an application specific integrated circuit (ASIC) including circuit modules for performing signal processing including signal modulation and demodulation. HAN modem ASIC 503 additionally includes an AFE interface 508, a PCI interface 506 and a video interface 507. PCI interface 506 provides the interface formatting and hand shake signals used to communicate with the CPU on network client 302 over a PCI bus. In an alternative embodiment, communication with the network client CPU is over an ISA bus. Video interface 507 couples a digital video stream, such as received from a satellite (DSS/DVB) receiver to the HAN modem ASIC 503. Advantageously, video connector 505 and video interface 507 together allow any NIC 500 to directly forward a digital video stream from a source (such as a digital cable TV receiver, or a satellite receiver) onto HAN 300 without requiring the host CPU (the network client CPU) to receive the video and without routing the video over the PCI bus. This direct interface improves system performance and makes each NIC 500 "video ready".

In another preferred embodiment, network client 302 is not connected to HAN 300 via NIC 500 but instead is connected via a HAN peripheral device external to network client 302. Figure 5B shows a HAN peripheral device 510 in accordance with the invention. HAN peripheral device 510 includes RJ-11 jacks 511, AFE block 512, HAN modem ASIC 513, digital video connector 514 and external interface bus 515. Interface bus 515 is a conventional interface bus such as USB or IEEE 1394 (FireWire). HAN modem ASIC 513 includes signal processing functionality (e.g., modulation and demodulation), an AFE interface, digital video interface and an external bus interface. HAN peripheral device 510 allows any network client 302 with a USB or IEEE 1394 (FireWire) interface to connect to HAN 300.

In alternative embodiments, HAN modem ASICs 503 and 513 additionally include POTS modem functionality (e.g., V.34 or V.56) thereby providing access to both HAN network signals and to conventional POTS signals. Further in accordance with this embodiment, AFE blocks 502 and 512 additionally include a conventional PSTN Data Access Arrangement (DAA) to provide POTS modem capability. This added POTS modem capability advantageously provides a user with connectivity to both the HAN and conventional telecommunications services on a single NIC 500 (or HAN peripheral device 510).

NIC 500 provides processing circuitry to demodulate and decode HAN signals on the receive side and to encode and modulate HAN signals on the transmit side. In a preferred embodiment, HAN signals are modulated using quadrature phase shift keying (QPSK). QPSK modulation is a relatively simple and thus a low cost modulation scheme, though not noted for spectral efficiency. Advantageously, the system is not constrained to a narrow spectral band due to the relatively short lengths of UTP installed at a customer premises. As discussed previously, as the length of UTP increases, signal attenuation becomes a limiting factor, particularly at higher signal frequencies. Therefore, bit rates are maintained by using spectrum up to 40MHz. In an alternative embodiment, HAN signals are

modulated using quadrature amplitude modulation having either 4 states (QAM-4) or 16 states (QAM-16).

Figure 6 is a functional block diagram of the receive-side processing 600 performed by HAN modem ASIC 503, 513. The processing blocks include gain control amplifier 601, AGC loop filter 602, ADC 603, interpolator/DDC 604, 5 Nyquist filter 605, clock recovery 606, AGC 607, adaptive equalizer 608, demap and differential decoder 609, carrier recovery module 615 and forward error correction logic 610. Forward error correction logic 610 includes viterbi decoder 611, convolutional de-interleaver 612, Reed-Solomon decoder 613 and 10 descrambler 614. The receive side processing blocks process, demodulate and decode a differentially encoded analog signal received from the HAN.

The received analog signal is coupled to gain control amplifier 601. The voltage of the received signal is first adjusted by gain control amplifier 601 to bring the signal into a preferred range for linear sampling by analog to digital 15 converter (ADC) 603. The sampled received signal is then fed to an interpolator/digital down converter (DDC) 604. Interpolator/DDC 604 downconverts the passband input signal to baseband. Interpolator/DDC 604 is driven by clock recovery circuit 606 and carrier recovery module 615 to generate four samples per symbol. Clock recovery circuit 606 recovers the symbol clock. 20 Carrier recover module 615 recovers the carrier frequency. In some implementations, in order to decrease the clock rate of the subsequent downstream processing, the incoming data is split into inphase and quadrature streams (not shown), typically with two samples per symbol. The data are then passed through matching Nyquist filter 605 for optimal signal detection. After filtering, the signal 25 is coupled to adaptive equalizer 608 which removes the intersymbol interference caused principally by the hostile reflection/environment of customer premises wiring (POTS wiring). Equalization is carried out prior to any processing which is not linear time invariant such as the decision circuitry in demap and differential decode 609. Demap and differential decoder 609 includes a demapper and a 30 differential decoder. The demapper decodes the output symbol into a serial bit

stream according to the constellation transmitted (2 bits for QPSK or QAM-4, 4 bits for QAM-16), and then the result is passed through the differential decoder. The received analog data stream is differentially encoded on the transmit side to allow simple coherent detection and prevent phase ambiguities in the recovered carrier from resulting in inaccurate data recovery.

The receive side processing blocks also include circuit blocks for clock recovery (clock recovery 606), carrier recovery module 615, and automatic gain control (AGC 607). The clock and carrier recovery circuits 606, 615 utilize phase lock techniques to maintain lock in the presence of noise. They also include sweep generators for initial signal acquisition. When, in an alternative embodiment, the gain control amplifier 601 is located externally to HAN modem ASIC 503, 513, either as a separate amplifier, or within a tuner, AGC 607 generates a PWM signal that is low pass filtered using an external LC filter (not shown).

The differentially decoded serial bit stream then enters forward error correction (FEC) logic 610. Preferably, data is encoded using a block outer code, such as Reed-Solomon, followed by a convolutional inner code. Viterbi decoder 611 recovers the convolutionally encoded data. Convolutional de-interleaver 612 then de-interleaves the data. Next, a Reed-solomon decoder 613 verifies and error corrects the data using the check data added to the bitstream. Depending on the propensity of the channel to burst noise, the data may have been interleaved to effectively spread the burst errors over time where they can be effectively corrected by the convolutional and/or block coding. Although shown as part of the FEC block, the function of descrambler 614 is to recover the bit stream that was randomized in order to spread the transmit signal energy and prevent any prominent spectral lines that might arise due to periodic data patterns in the bit stream.

The result of processing in accordance with the functional blocks shown in Figure 6 is a received digital bit stream that is coupled to the network client CPU using the appropriate interface protocol (e.g., PCI, ISA, USB, IEEE 1394).

Figure 7 is a functional block diagram of the transmit-side processing blocks 700 of HAN modem ASIC 503, 513. The transmit-side processing blocks include forward error correction encoder 701 (including Reed-Solomon encoder 703, convolutional interleaver 704, viterbi encoder 705), scrambler 702, mapper and differential encoder 706, Nyquist filter 707, interpolator 708, digital mixer 709, digital-to-analog converter (DAC) 710. Digital mixer 709 includes number controlled oscillator (NCO) 711, multipliers 712 and adder 713.

In operation, HAN modem ASIC 503, 513 receives a digital bit stream for transmission over HAN 300. The incoming bit stream is first randomized by scrambler 702. Scrambler 702 uses a linear feedback shift register implementing a fifteenth order generator polynomial. This scrambling disperses the transmit energy throughout the available band and prevents the emergence of strong spectral lines corresponding to periodic data in the input stream. The randomized output is then fed into the FEC 701, which includes an outer code implemented using a Reed-Solomon block, followed by a Viterbi convolutional inner code. Depending on the propensity of the channel to burst noise, the data is also interleaved using convolutional interleaver 704 to effectively spread the burst errors over time where they can be corrected by the convolutional and/or block encoding.

Mapper and differential encoder 706 next receives the serial bit stream for processing. The serial bit stream is mapped into symbol space according to the constellation in use (2 bits for QPSK or QAM-4, 4 bits for QAM-16), and differentially encoded to facilitate coherent detection and unambiguous carrier/phase recovery at the receiver. This processing generates symbol data.

The symbol data is then Nyquist filtered using Nyquist filter 707 to bandlimit the signal to the minimum required for symbol recovery, and minimize intersymbol interference. Nyquist filter 707 is preferably realized using a transversal finite impulse response (FIR) structure.

The filtered symbol data is then interpolated by interpolator 708 before being mixed (by digital mixer 709) into the in-phase and quadrature phase components of the PSK signal. A numerically controlled oscillator 711 (preferably

implemented using a table lookup) provides the sine and cosine coefficient data. The quadrature components are then summed using summer 713 (preferably resistively) prior to being fed to DAC 710.

Now referring again to Figures 5A, 5B, the analog transmission signal generated by HAN modem ASIC 503, 513 is next coupled to POTS wiring 301 via AFE 502, 512. The resulting analog transmission signal is a bandpass signal that occupies a region of the spectrum above the portion occupied by conventional POTS services. Thus, the analog transmission signals (the HAN network signals) are transmitted using the POTS wiring 301 at a customer premises 306 without interfering with conventional POTS signals. Advantageously, HAN network signals and conventional POTS services signals (e.g., conventional call connections and xDSL signals) simultaneously use the same wiring infrastructure at a customer premises. The installation of a separate client network infrastructure is avoided and instead existing POTS wiring is leveraged for a second, additional use.

In a preferred embodiment, network clients 302 share the HAN bandwidth in accordance with a time division multiple access (TDMA) protocol. In the preferred HAN embodiment where only one spectral band is utilized, only one receiver/transmitter pair of network clients 302 communicates at a time and each receiver/transmitter pair are allocated a time slot for communication. Network usage thus transitions from one receiver/transmitter pair to the next. In this approach, overall network performance is significantly affected by the speed at which receiver/transmitter network client 302 pairs effectively transition into network usage. To effect this transition efficiently, selected signal processing control and configuration parameters used in the receive and transmit processing 600, 700 shown in Figures 6 and 7 are predetermined during an initialization process and then stored locally on the HAN modem ASIC 503. The stored parameters are then used to initialize both the receive-side and transmit-side processing 600 and 700, respectively each time a receiver/transmitter pair initiates communication.

In particular, during the HAN system initialization process, training is conducted to determine and store processing parameters associated with each receiver-transmitter network client pair (e.g., each communication channel). During network operation, HAN signals (the modulated information signals) are modified in accordance with the stored processing parameters for the associated receiver/transmitter pair. Keeping local copies of processing parameters at each network client avoids retraining each time a receiver is to receive data from a new transmitter and allows rapid switching of receivers and transmitters.

In one embodiment, the stored processing parameters (modem parameters) include are a set of adaptive equalization coefficients associated with adaptive equalizer 608 and the HAN signals are modified by applying an equalization filter using the adaptive filter coefficients. In accordance with this embodiment, the initialization process includes a training session for each communication channel to generate a set of adaptive filter coefficients that match the characteristics of the channel. By determining and storing the coefficients for each channel during an initialization process, network throughput and performance is improved.

Other modem parameters which are preferably predetermined and stored include control parameters for AGC 607, for clock recovery 606, carrier recovery 615, and NCO 711 and filter coefficients for Nyquist filter 605, Nyquist filter 707, and interpolator 708.

In accordance with another embodiment of the present invention, the system and method monitors the channel characteristics associated with a plurality of communication channels to detect any change in the channel characteristics. After detecting a change, the system and method can either update the current modem parameters from the stored set of pre-trained parameters, or request that the system retrain. This embodiment of the invention is particularly advantageous during network operation when the network experiences a change in configuration such as when a telephone "ring" signal is received or when a telephone receiver is picked up or when the network is physically modified by the addition of a stub such as occurs when an additional telephone is plugged in.

In accordance with still yet another embodiment of the invention, the system and method implements an adaptive error correction scheme. The system and method determines the type of the data being communicated. For example, the system and method determines whether the data is voice data, text data, graphic, video and so forth. After determining the data type, the system and method selects and applies one of a plurality of error correction methods responsive to the determined data type. Further in accordance with this embodiment of the invention, the system and method additionally or alternatively determines the channel characteristics associated with the receiver-transmitter pair and selects one of the plurality of error correction methods responsive to the channel characteristics. Advantageously, such an adaptive error correction method provides for the selection of a preferred error correction method (e.g., one better suited for video as opposed to graphics or text etc.) based on data type as well as on the particular characteristics associated with the channel to improve channel throughput or to reduce channel latency.

Referring back again to Figure 3, HAN 300 performance is improved using a symmetric passive lowpass filter (filter) 308 at the telephone network interface (TNI). The telephone network interface is the demarcation point between the customer premises and the subscriber loop. Filter 308 prevents HAN signals from being placed on subscriber loop 306 and prevents noise generated on subscriber loop 306 in the HAN spectral range from intruding on HAN 300. Figure 8 shows filter 308 coupled to TIP and RING lines on both the subscriber loop side and the customer premises side at the TNI. Filter 308 has a cutoff frequency above the frequency of the POTS services signals (e.g., above 1.1MHz for POTS services including ADSL). Signals passing from the customer premises to the subscriber loop are lowpass filtered and similarly, signals passing from the subscriber loop to the customer premises are lowpass filtered. As stated previously, one advantage of the spectral avoidance/FDM technique of the present invention is the interoperability with legacy communications standards such as POTS, ISDN, and xDSL. Two further advantages are that the spectral allocation of the HAN can be

moved even higher up the spectrum (as shown in Figure 4B) to: (i) avoid noisy areas of the spectrum and improve the overall system signal to noise ratio; and (ii) facilitate embodiments wherein filters 308 are inexpensive passive filters having less stringent design requirements.

5 To understand the impact of HAN spectral allocation on the design criteria imposed on filter 308, the filter requirements stemming from a HAN allocation just above ADSL (e.g., above 1.1MHz) is discussed. Then, for comparison, the design criteria imposed on filter 308 when HAN spectral allocation is several MHz above ADSL (e.g., 3 or 4MHz or higher) is discussed.

10 In the first example, the goal is to design a passive lowpass filter to pass ADSL signals, but not signals in the HAN spectral range, and to place the bottom of the HAN spectral range close to the upper edge of the ADSL band (e.g., close to 1.1MHz). As ADSL signals generally have significantly reduced energy by the time they reach the customer premises, any additional insertion loss or
15 modification of the ADSL signal would degrade reception. Therefore, the HAN lowpass filters (and diplexers) are designed for maximum transparency in the lowpass filter passband. The filter is preferably designed with a cutoff frequency near the top of the ADSL band with a steep rolloff to avoid interference in the HAN spectral band. A passive 5th order Chebychev lowpass filter with 0.2 dB of
20 ripple in the passband and a cutoff frequency of 1.2MHz meets this design criteria. Such a filter gives essentially flat attenuation throughout the ADSL passband of 1.1MHz, and provides 35dB of attenuation by 2MHz.

Figure 12 shows the group delay associated with this filter. As the group
25 delay graph of this filter shows, there is a significant increase in group delay (over 500 nanoseconds) near the top of the ADSL passband. This rapid increase in group delay added by the passive filter could impair the ability of ADSL modems to equalize the line. This type of group response, where there is a rapid increase in group delay near the cutoff frequency, is typical of passive ladder filters of the Butterworth/Chebychev type. The group delay peak increases rapidly as the filter
30 order is increased.

However, as the lower edge of the HAN spectral range is moved up in frequency (e.g., move the HAN band up the spectrum), the design criteria for filter 308 relaxes. The cutoff frequency of the filter 308 also moves up. As a result, the area of poor group delay characteristic also moves up and into the unused frequency range between the top of the ADSL passband and the bottom of the HAN spectral range. For example, consider the selection of design criteria in a system using HAN band 411 having a lower frequency of 4MI-Iz. Figure 13 graphs the group delay characteristics of a passive 5th order Chebychev lowpass filter with 0.2dB of ripple in the passband and a cutoff frequency of 2.5MHz. The group delay increases over 300ns from 1.5MHz to 2.5MHz, and in particular there is a rapid increase in group delay from 2.1MHz to 2.3MHz, but this will not adversely affect either the HAN or ADSL signaling because the increase occurs in the transition band. The filter gives essentially flat attenuation and constant group delay throughout the ADSL passband, yet provides 35dB of attenuation by 4MHz. Note that moving the cutoff frequency up to 2.5MHz substantially decreases the values of the inductive elements in the filter - this is beneficial because smaller inductors cost less, and have higher self resonance frequencies.

Further movement of the bottom of the HAN spectral range up in frequency would allow the use of lower order filters with shallower rolloff, thus saving cost. Lowpass filter 308 reflects signal energy in the filter stopband (e.g., in the HAN spectral range) back onto the POTS wiring. This reflected energy degrades signal quality, and although this can be compensated for using adaptive equalization at the receiver, it is advantageous if lowpass filter 308 is replaced at the TNI by a diplexer filter. Figure 9 shows a passive diplexer filter 900. Use of diplexer filter 900 at the TNI advantageously provides a matched termination impedance to HAN 300 at HAN 300. operating frequencies starting in the 3-4MHz range. Matching termination impedance advantageously reduces signal reflections on HAN 300 thereby improving signal quality. Diplexer filter 900 includes a 100 ohm resistor 901, highpass filter 902 (having a passband starting in the 3-4MHz range - corresponding to the HAN operating frequency range) and

lowpass filter 903 (having a cutoff not below 1.2MHz). Lowpass filter 903 is connected in-line with the POTS wiring 301 at the telephone network interface. Termination resistor 901 is coupled to HAN 300 via highpass filter 902. Thus, the impedance matching effect of termination resistor 901 is limited to frequencies in the passband of highpass filter 902. For frequencies at which HAN 300 operates, and also the frequencies that highpass filter 902 passes signals, the impedance (z) of POTS wiring 301 has an almost purely resistive impedance that is closely approximated by the 100 ohm resistor 901.

Figure 10 shows HAN 1000, an alternative embodiment of a HAN in accordance with the present invention. HAN 1000 includes passive duplex filters 1001 at the interface of customer premises equipment (e.g., POTS telephones 1002 and modem 1003). HAN 1000 additionally includes POTS wiring 1004 and network clients 1005. HAN 1000 couples network clients 1005 to form a computer network using existing customer premises wiring (POTS wiring 1004) by frequency division multiplexing as discussed in reference to Figure 3. Filters 1001 improve HAN 1000 performance by (i) preventing energy in the HAN spectral range (e.g. starting at 3-4MHz) from entering POTS wiring 1004; (ii) preventing energy in the HAN spectral range from being aliased down to the operating frequency range of the customer premises equipment (POTS telephones 1002 and modem 1003); and (iii) providing a matched termination to HAN 1000. Matching the termination of HAN 1000 is particularly advantageous in the case of POTS telephones which change impedance in the HAN spectral range when switching from on hook to off hook (e.g., when the handset is picked up).

Figure 11 is a block diagram of the duplex filters 1001 used at the interface of the POTS telephones 1002 and modem 1003 as shown in Figure 10. Filter 1001 includes a 100 ohm resistor 1101 coupled to a highpass filter 1102 (having a pass band starting between 3 and 4MHz) and a lowpass filter 1103 (having a cutoff not below 1.2MHz). Resistor 1101 provides a matched termination to HAN 1100~; at its operating frequencies. Passive duplex filter 1001 also prevents energy in the

HAN spectral range from entering the subscriber loop, and energy in the HAN spectral range on the subscriber loop from entering premises POTS wiring 1004.

The filters shown in and described in reference to Figures 3 and 8-11 are preferably passive filters that support telephone voltages and currents. These
5 passive filters pass DC signals on the subscriber loop to the Customer premises wiring, even in the event of a power failure. Use of such passive filters in conjunction with the frequency division multiplexing (FDM) spectral avoidance technique of the present invention enable continued telephone service in the event of a local AC power failure ("lifeline services"). Ordinary telephone service
10 continues, despite the power failure, because conventional POTS telephones operate off of a DC current supplied by the central office. Advantageously, there is thus no need for a backup battery to ensure continued availability of telephone service in the event of a power failure. In contrast, conventional PBX systems located at a customer premises cannot offer lifeline service unless they also provide
15 battery backup. This is because they are installed between the subscriber loop and the customer premises wiring and thus "break" the electrically contiguous subscriber loop which ordinarily provides the DC current.

It should be understood that in alternative embodiments, the baseband signals occupying the POTS wiring are derived from sources other than the
20 subscriber loop. In other embodiments, the baseband signals are derived from a wireless telecommunications link, a coaxial cable-based source or other wide area networking means. For example, alternative embodiments support delivery of broadband digital data throughout the home from varied sources such as satellite
(DSS/DVB), terrestrial microwave (MMDS), digital cable/CATV ("All Tv"),
25 digital or high definition television (DTV/HDTV/ATV) and digital video disk (DVD) drive.

The above described HAN is an exemplary LAN that leverages use of existing customer premises POTS wiring. Network signals generated by the HAN coexist with POTS connection signals and with xDSL signals on an already
30 installed wiring network (POTS wiring) at a customer premises. POTS signals are

WAN signals in that they can be associated with the PSTN, with a connection local to the central office or another type of connection to a telecommunications device located remote for the customer premises. xDSL signals are associated with yet another WAN. Thus, signals from three distinct networks (the PSTN, the xDSL
5 WAN and the HAN) coexist on a single electrically contiguous wiring infrastructure at a customers premises. It is desirable to provide communication among the three distinct networks. It is further desirable to provide such communication without breaking the continuity of the POTS wiring installed at the customer premises in order to maintain lifeline POTS services. It should be
10 understood that if the existing POTS UTP wiring is to be used as the communications medium for all three networks, maintaining lifeline POTS services precludes breaking the line and the insertion of an active device that prevents DC current flow upon loss of AC power. Such internetwork communication and delivery of lifeline POTS service is realized using a virtual
15 gateway in accordance with the present invention. Furthermore, the gateway functionality can be provided by an existing PC coupled to the premises POTS wiring without the addition of a new dedicated gateway hub device.

Figure 14A illustrates a customer premises system 1400 providing access to, and interconnection among, three distinct device networks: POTS -based WAN
20 1402, ADSL-based WAN 1403 and HAN 1404. It should be understood that, as used herein, POTS- and ADSL- "based" WANs include WANs that are accessed via POTS and ADSL services, respectively, over the subscriber loop. Thus, the physical layer signaling protocol is either POTS or ADSL. WAN 1403 and WAN
1402, however, may both use the same higher layer protocols. In fact the ADSL
25 based WAN 1403 and the POTS based WAN 1402 may even be configured to access the same network (e.g. the Internet). Through the POTS subscriber loop, using the POTS physical layer protocol, one can access the PSTN or any number of other networks. Through the POTS subscriber loop, using the ADSL physical layer protocol one can access a number of, possibly similar, networks.

Referring still to Figure 14A, system 1400 includes a virtual gateway (a gateway server) 1401 that facilitates the communication among the distinct networks 1402-1404. The customer premises system 1400 also includes HAN network clients 1405 interconnected via HAN 1404 using installed POTS wiring 1407. System 1400 further includes telephones 1406 coupled to POTS-based WAN 1402 via installed POTS wiring 1407 and coupling devices 1408.

Virtual gateway 1401 is a gateway server that operates as a gateway providing HAN 1404 with bi-directional communication with WANs 1402 and 1403. Virtual gateway 1401 is a personal computer having a plurality of network interface cards as described in reference to Figure 14B above. Virtual gateway 1401 additionally includes a gateway software module that performs a virtual gateway method to effect network protocol conversion and communication among devices from the distinct networks 1402, 1403 and 1404. HAN network clients 1405 are network clients associated with (interconnected by) HAN 1404.

HAN network clients 1405 are personal computers each equipped with a network interface card 500 described in reference to Figure 5A above. It should be understood, however, that the principles of the present invention apply to virtual gateways 1401 serving other types of network clients such as specific purpose computers, computer appliances, computer-enabled devices or other types of network devices.

POTS wiring 1407 is conventional UTP wiring that is generally routed internally in the walls of a customer premises (e.g., a house) to various locations (e.g., rooms) within the customer premises. POTS wiring 1407 is coupled to a telephone central office via a subscriber loop.

HAN 1404 is a home local area network as described in reference to Figures 3-11 above. HAN 1404 occupies a selected spectral band on POTS wiring 1407. It should be understood that although HAN 1404 is shown in Figure 14A as a separate entity from POTS wiring 1407, HAN network clients 1405 and virtual gateway 1401 HAN 1404 use (and thus includes) POTS wiring 1407 to interconnect HAN network clients 1405 and virtual gateway 1401.

Coupling devices 1408 are combined HAN filter and POTS splitter devices that perform passive filtering and impedance matching discussed above. Coupling devices 1408 provides a matched termination to the HAN in the HAN spectral range and includes a low pass filter having a cutoff frequency at the low end of the ADSL band (near 25KHz).

Virtual gateway 1401 sends and receives signals in the spectral ranges associated with each of the distinct networks 1402-1404 to effect bi-directional communication from HAN 1404 to WANS 1402 and 1403. Each HAN network client 1405 associated with HAN 1404 sends and receives signals limited to the HAN spectral domain and virtual gateway 1401 "hops" network traffic between the spectral domains of WANs 1402, 1403 and HAN 1404 to effect a bridge between the networks. Data received from a WAN (either 1402 or 1403) is first down converted to baseband, processed for network protocol conversion then upconverted to the HAN spectral range and then retransmitted on HAN 1404 so that it can be received by the appropriate HAN network client 1405. Conversely, data received from a HAN network client 1405 bound for either WAN 1402 or 1403 is transmitted over the HAN to virtual gateway 1401 for conversion down to baseband, network protocol conversion and followed by modulation in accordance with the requirements of the destination WAN and retransmission on the (to the) destination WAN. Other implementations described below in reference to Figures 16 and 17 improve upon HAN bandwidth utilization. The implementation described in reference to Figure 14A, however, reduces the complexity of the network interface card 500 installed in each HAN network client 1405.

Figure 14B is a functional block diagram of virtual gateway server 1401. Virtual gateway server 1401 is a personal computer 1422 running virtual gateway software 1426 and equipped with a HAN NIC 500, a POTS modem card 1420 and an ADSL modem card 1421. Virtual gateway software 1426 executes on virtual gateway 1401 and processes baseband data received from POTS modem card 1420 and ADSL modem card 1421. The baseband processing performed by virtual gateway software 1426 performs network protocol conversion to convert data from

the protocol associated with the sending network to the protocol associated with the receiving network. HAN NIC 500 is the HAN NIC described above in reference to Figure 5A. HAN NIC 500 is coupled to the customer premises wiring 1407 (shown in Figure 14A) via an RJ-11 jack 1423.

5 POTS modem card 1420 is a conventional POTS modem card that provides modem (modulation-demodulation) functionality using the POTS portion of the spectrum. POTS modem card 1420 is coupled to a coupling device 1424 that includes an ADSL POTS splitter low pass filter and HAN terminating matching impedance. POTS modem card 1420 is coupled to customer premises wiring 1407
10 via an RJ-11 jack 1423 and coupling device 1424.

ADSL modem card 1421 is a conventional ADSL modem card that provides ADSL modem (modulation-demodulation) functionality. ADSL modem card 1421 is coupled to coupling device 1425. Coupling device 1425 includes an ADSL POTS splitter high pass filter and a HAN filter that has a stop band in the
15 frequency range corresponding to the HAN. ADSL modem card 1421 is coupled to customer premises wiring 1407 via an RJ-11 jack 1423 and coupling device 1425.

Figure 15 illustrates an example of the internetworking functionality that can be provided by virtual gateway server 1401. Specifically, virtual gateway
20 server 1401 provides communication between an asynchronous transfer mode (ATM) WAN and the TcP/IP HAN.

In this embodiment, the ADSL-accessed WAN provides ATM services directly to the premises through the ADSL modem, and the HAN provides
25 transmission control protocol/Internet protocol (TcP/IP) services between the HAN clients on the premises distribution network. In order to successfully internetwork these dissimilar networks, the virtual gateway provides functionality on a number of different levels according to the standard reference models.

Figure 15 shows the TcP/IP layers 1501 in the standard OSI reference model and the ATM layers 1502 using the B-ISDN ATM reference model. Rough
30 functional equivalence between the models layers can be seen by their horizontal

adjacency in the diagram. For example, the physical layer 1501a of the HAN corresponds to transmission convergence sublayer 1502b and physical medium dependent sublayer 1502a. Similarly, application layer 1501e of the HAN corresponds to application layer 1502f of the ADSL ATM network.

5 Gateway server 1401 provides the HAN physical and data link layer functionality primarily through the HAN NIC card 500, although some of the data link layer may be implemented by virtual gateway software 1426 on the gateway server 1407. The Tcp/IP functionality found in layers three (Network) and four (Transport) of the OSI model (1501c, d) are conventionally provided as a portion
10 of the server PC operating system. The ADSL layers shown in the diagram are provided by a conventional ADSL modem/NIC card (not shown), although some of the ATM functionality, particularly the AAL sublayers (1502d, e) and ATM layer 1502c may be provided by software running on the gateway server PC.

The virtual gateway software 1426 running on the server PC implements
15 protocols between the various layers 1501 and 1502 in the two reference model stacks. Virtual gateway software 1426 allows applications running on the ATM network (the ADSL-accessed network) to communicate with applications running on the Tcp/IP HAN network. In order to accomplish this, virtual gateway software 1426 handles protocol issues at the various levels, including, but not limited to,
20 address resolution, routing, segmentation and reassembly, flow control/traffic shaping, error management, acknowledgments, synchronization, QoS issues, security issues, accounting issues, and multicasting/broadcasting issues. ATM is a connection oriented/virtual circuit, cell oriented technology with strong focus on QoS, whereas Tcp/IP is a connectionless datagram oriented service, therefore the
25 protocol differences between the two networks are significant.

Virtual gateway software 1426 thus provides a baseband channel (a communication means) between the HAN NIC 500 and the ADSL modem card both installed in gateway server 1401.

It should be understood that the xDSL accessed WAN need not be an ATM
30 network, but rather it could be a TCP/IP network or any number of different

network types. The internetworking issues surrounding communicating with any dissimilar network are similar to those outlined above.

The system 1400 described in reference to Figure 14A is a centralized gateway system. Alternative embodiments of the invention use either a partially distributed gateway or a fully distributed gateway. Fully and partially distributed virtual gateways described below in reference to Figures 16 and 17, respectively, improve HAN bandwidth utilization as compared to use of a central virtual gateway.

Figure 16 illustrates a customer premises having a fully distributed virtual gateway system 1600 that provides access to distinct networks 1602, 1603 and 1604.

WAN 1602 is a POTS-based network, WAN 1603 is an xDSL accessed WAN and HAN 1604 is a home local area network as described above in reference to Figures 3-11. Access to each network 1602-1604 is provided using installed POTS wiring 1607. Telephones 1606 are coupled to POTS-based WAN 1602 via coupling devices 1609 and POTS wiring 1607. HAN network clients 1605 are each coupled to HAN 1604 and to xDSL-based WAN 1603 using existing POTS wiring 1607 accessed via an RJ-11 telephone jack 1611. In this fully distributed implementation, the gateway/bridge functionality is not centralized, and instead each HAN network client 1605 both sends and receives information on either HAN 1602 or WAN 1603. This distributed implementation results in improved system flexibility and robustness but increases the complexity of each HAN network client 1605. Overall throughput on all of the networks is optimized because data does not need to be "hopped" or retransmitted on any of the networks.

HAN network clients 1605 are conventional personal computers or other network client devices equipped with a HAN NIC 500 as described above in reference to Figure 5. HAN network client 1605 additionally includes a conventional ADSL modem card 1610. ADSL modem card 1610 performs both transmit and receive functions to transmit and receive signals in accordance with ADSL format and protocol. Both the HAN NIC 500 and ADSL modem 1610 are

coupled to POTS wiring 1607 via RJ-11 jack 1611. The ADSL modem 1610, however, is coupled to RJ-11 jack 1611 via ADSL coupling device 1612. ADSL coupling device 1612 has an ADSL POTS splitter portion that is a high pass filter as well as a HAN filter (providing filtering in the HAN spectral range).

5 Figure 17 illustrates a customer premises system 1700 having a partially distributed virtual gateway. System 1700 provides access to distinct networks 1702, 1703, and 1704. Network access is provided using installed POTS wiring 1707, a gateway server 1701 and a uni-directional gateway at each HAN client 1705. In this implementation, HAN clients 1705 receive WAN (1702,1703) data
10 directly but send data to the destination WAN by going through gateway server 1701. System 1700 thus provides distributed "receive", side access to ADS[-accessed WAN 1703. This partially distributed implementation is preferred for broadcast type WAN data such as video on-demand (VOD). System 1700 provides conventional telephones 1706 with access to POTS-based WAN 1702 via passive
15 coupling device 1708.

HAN clients 1705 are conventional personal computers or other network client devices equipped with a HAN NIC 500 as described above in reference to Figure 5. HAN network client 1705 is additionally equipped with an ADSL
20 modem card 1711. ADSL modem card 1711 is a "receive only" modem card that provides ADSL receiving functionality. ADSL modem card 1711 is coupled to POTS wiring 1707 via RJ-11 jack 1712 and coupling device 1713. Gateway server 1701 is coupled to POTS wiring 1707 via RJ-11 jack 1712. Gateway server 1701 is a personal computer equipped with an ADSL modem card 1714 as well as a
25 HAN NIC 500. ADSL modem card 1714 is a "transmit only" ADSL modem card that provides ADSL transmit capability.

Figure 18 shows another embodiment of a virtual gateway system 1800 in accordance with the present invention. This embodiment provides two distinct home local area networks (HANs) using installed customer premises wiring and further provides interconnectivity between the district HANs as well as between
30 each HAN and various WANs accessed using the installed customer premises

wiring. The system 1800 includes POTS-based WAN 1801, ADSL-accessed
WAN 1804, first HAN (HAN1) 1803 and second HAN (HAN2) 1810
interconnected via POTS wiring 1811. Figure 19 illustrates the spectral allocation
(the spectrum 1900) of the POTS wiring 1811. POTS signals 1901 occupy
5 baseband up to approximately 4 KHz. ADSL upstream signals 1902 occupy
spectrum from approximately 25 KHz to 1.1 MHz; ADSL downstream signals
1903 occupy from approximately 140 KHz to 1.1 MHz. The spectrum 1900 also
includes a dead band 1904 separating HAN1 spectrum 1905 from the ADSL
signals 1903. HAN1 spectrum 1905 occupies approximately from 4 MHz to 10
10 MHz and HAN2 spectrum 1907 occupies from approximately 14 MHz to 20 MHz
with HAN1 spectrum 1905 and HAN2 spectrum 1907 being separated by a dead
band 1906.

Referring now back to Figure 18, system 1800 includes a plurality of
HAN1 clients 1805, a plurality of HAN2 clients 1806 as well as conventional
15 telephones 1808 coupled to customer premises wiring (POTS wiring) 1811 via
passive coupling devices 1807. System 1800 also includes a central virtual
gateway 1809.

HAN1 1803 provides communication among HAN1 clients 1805 using
information signals confined to the spectral band associated with HAN1 1803 as
20 shown in Figure 19. Similarly, HAN2 1810 provides communication among
HAN2 clients 1806 using information signals confined to the spectral band
associated with HAN2 1810 as shown in Figure 19. Information is transferred
between HAN1 1803 and HAN2 1810 using virtual gateway 1809.

Virtual gateway 1809 includes a HAN NIC (as described above in reference
25 to Figure 5) for each of HAN1 1803 and HAN2 1810. Virtual gateway 1809
additionally includes an ADSL modem card allowing bi-directional
communication with WAN2 1804 and a POTS modem card for communicating
with networks accessed using conventional POTS-compatible modems. Thus, two
distinct local area networks (HAN1 1803 and HAN2 1810) coexist on the same

wiring infrastructure (customer premises wiring) that also delivers conventional POTS services.

It should be understood that although the above described embodiments have modem cards (e.g., HAN NIC cards, ADSL modem cards and POTS modem cards) that are separate circuit cards, other embodiments of the invention combine one or more of the above described modems into a single modem chip located on a single modem card.

The foregoing discussion discloses and describes merely exemplary methods and embodiments of the present invention. As will be understood by those familiar with the art, the invention may be embodied in other specific forms without departing from the spirit or essential characteristics thereof. Accordingly, the disclosure of the present invention is intended to be illustrative, but not limiting, of the scope of the invention, which is set forth in the following claims.

CLAIMS

What is claimed is:

- 5 1. A virtual gateway system for providing bi-directional communication between a first device network and a second device network, comprising:
- a shared electrically contiguous communication channel coupled to each of the device networks, the shared electrically contiguous communication channel
- 10 having first and second separate spectral bands associated with the first and second device networks respectively; and
- a gateway server operatively coupled to the shared electrically contiguous communication channel, the gateway server including;
- a first modem associated with the first device network, having:
- 15 a receive portion having an input coupled to the shared communication channel, the receive portion for converting information in the spectral band associated with the first device network to baseband; and
- a transmit portion having an output coupled to the shared communication channel, the transmit portion for converting baseband information
- 20 to the spectral band associated with the first device network;
- a second modem associated with the second device network, having:
- a receive portion having an input coupled to the shared
- communication channel for converting information in the spectral band associated
- 25 with the second device network to baseband; and
- a transmit portion having an output coupled to the shared communication channel, the transmit portion for converting baseband information to the spectral band associated with the second device network; and

a baseband communication channel coupled to the first and second modems for communicating baseband signals between the first and second modems.

5 2. The system of claim 1 further comprising:

a network protocol translator coupled to the baseband communication channel for translating baseband information from a first protocol associated with the first device network to a second protocol associated with the second device network.

10

3. The system of claim 1 wherein the shared communication channel is unshielded twisted pair wiring coupled to a telephone central office by a subscriber loop.

15

4. The system of claim 3 wherein the first device network is a local area network having a plurality of network clients and access to the second device network is provided by a digital subscriber line (xDSL).

20

5. The system of claim 4 wherein the xDSL is an asymmetrical digital subscriber line (ADSL).

6. The system of claim 3 wherein both the first and second modems of the gateway are located at a single server device.

25

7. The system of claim 1 wherein the first device network is a local area network having a plurality of network clients and the second device network is an integrated services digital network (ISDN) wide area network.

8. The system of claim 1 wherein the first device network is a local area network having a plurality of network clients and the second device network is a wide area network.

5 9. The system of claim 1 wherein the first device network is a first local area network and the second device network is a second local area network.

10. The system of claim 3 wherein the first device network is a first local area network and the second device network is a second local area network.

10

11. A virtual gateway system for providing bi-directional communication between a first device network and a second device network, comprising:

15 a shared communication channel coupled to each of the device networks, the shared communication channel having first and second separate spectral bands associated with the first and second device networks respectively; and

a plurality of client devices each including:

a first modem associated with the first device network, having:

20 a receive portion having an input coupled to the shared communication channel, the receive portion for converting information in the spectral band associated with the first device network to baseband; and

a transmit portion having an output coupled to the shared communication channel, the transmit portion for converting baseband information to the spectral band associated with the first device network; and

25 a second modem associated with the second device network, each having:

a receive portion having an input coupled to the shared communication channel for converting information in the spectral band associated with the second device network to baseband; and

a transmit portion having an output coupled to the shared communication channel for converting baseband information to the spectral band associated with the second device network; and

5 a baseband communication channel coupled to the first and second modems for communicating baseband signals between the first and second modems.

12. The system of claim 11 further comprising:

10 a network protocol translator coupled to the baseband communication channel for translating baseband information from a first protocol associated with the first device network to a second protocol associated with the second device network.

13. The system of claim 11 wherein the shared communication channel is unshielded twisted pair wiring coupled to a telephone central office by a subscriber loop.

14. The system of claim 13 wherein the first device network is a local area network having a plurality of network clients and access to the second device network is provided by a digital subscriber line (xDSL).

15. The system of claim 14 wherein the xDSL is an asymmetrical digital subscriber line (ADSL).

25 16. The system of claim 13 wherein both the first and second modems of the gateway are located at a single server device.

17. The system of claim 11 wherein the first device network is a local area network having a plurality of network clients and the second device network is a integrated services digital network (ISDN) wide area network.

18. The system of claim 11 wherein the first device network is a local area network having a plurality of network clients and the second device network is a wide area network.

5

19. The system of claim 11 wherein the first device network is a first local area network and the second device network is a second local area network.

20. The system of claim 13 wherein the first device network is a first local area network and the second device network is a second local area network.

10

21. A virtual gateway system for providing bi-directional communication between a first device network and a second device network, comprising:

15

a shared communication channel coupled to each of the device networks, the shared communication channel having first and second separate spectral bands associated with the first and second device networks respectively; and

a plurality of client devices each including:

20

a first modem associated with the first device network, having:
a receive portion having an input coupled to the shared communication channel, said receive portion for converting information in the spectral band associated with the first device network to baseband; and

25

a transmit portion having an output coupled to the shared communication channel, said transmit portion for converting baseband information to the spectral band associated with the first device network; and

a gateway server having a second modem having:

a receive portion having an input coupled to the shared communication channel, the receive portion for converting information in the spectral band associated with the second device network to baseband; and

a transmit portion having an input coupled to the shared communication channel, said transmit portion for converting baseband information to the spectral band associated with the second network.

5 22. The system of claim 21 further comprising:

 a network protocol translator coupled to the baseband communication channel for translating baseband information from a first protocol associated with the first device network to a second protocol associated with the second device network.

10

 23. The system of claim 21 wherein the shared communication channel is unshielded twisted pair wiring coupled to a telephone central office by a subscriber loop.

15

 24. The system of claim 23 wherein the first device network is a local area network having a plurality, of network clients and access to the second device network is provided by a digital subscriber line (xDSL).

20

 25. The system of claim 24 wherein the xDSL is an asymmetrical digital subscriber line (ADSL).

 26. The system of claim 23 wherein both the first and second modems of the gateway are located at a single server device.

25

 27. The system of claim 21 wherein the first device network is a local area network having a plurality of network clients and the second device network is a integrated services digital network (ISDN) wide area network.

28. The system of claim 21 wherein the first device network is a local area network having a plurality of network clients and the second device network is a wide area network.

5 29. The system of claim 11 wherein the first device network is a first local area network and the second device network is a second local area network.

30. The system of claim 23 wherein the first device network is a first local area network and the second device network is a second local area network.

10

31. A method of providing communication between a first and second device network, comprising:

coupling a first and a second device network to a shared communication channel;

15

communicating among devices in the first device network using communication signals in a first spectral band on the shared communication channel;

communicating among the devices in the second device network using communication signals in a second spectral band distinct from the first spectral

20

band on the shared communication channel; and

converting information in the first spectral band to the second spectral band to transfer information from the first device network to the second device network.

32. The method of claim 31 further comprising coupling telecommunications circuit connections to the shared communication channel.

25

33. The method of claim 31 further comprising:

coupling the communication channel to a subscriber loop coupled to a central telephone office; and

coupling a plain old telephone service (POTS) compatible-device to the shared communication channel to connect the POTS compatible device to the central telephone office.

5 34. The method of claim 31 further comprising centralizing the conversion of information in the first spectral band to the second spectral band at a single gateway server.

10 35. The method of claim 31 further comprising distributing the conversion of information in the first spectral band to the second spectral band at across a plurality of client devices.

15 36. The method of claim 31 further comprising converting information in the second spectral band to the first spectral band to transfer information from the second device network to the first device network.

20 37. The method of claim 36 further comprising centralizing the conversion of information in the first spectral band to the second spectral and the conversion of information in the second spectral band to the first spectral band at a single gateway server.

25 38. The method of claim 36 further comprising distributing the conversion of information in the first spectral band to the second spectral band across a plurality of client devices and distributing the conversion of information in the second spectral band to the first spectral band across a plurality of client devices.

 39. The method of claim 36 further comprising centralizing the conversion of information in the first spectral band to the second spectral at a

single gateway server and distributing the conversion of information in the second spectral band to the first spectral band across a plurality of client devices.

40. A method for interconnecting a plurality of distinct device
5 networks, comprising:
- generating first network signals associated with a first device network having a first network protocol, said first network signals being in a first spectral band;
 - 10 generating second network signals associated with a second device network having a second network protocol, said second network signals being in a second spectral band;
 - coupling the first and second network signals generated by the first and second device networks to a shared communication channel;
 - 15 detecting network signals coupled to the shared communication channel in the first spectral band that are addressed to a device associated with the second device network; and
 - converting detected signals to a network signal compatible with the second network protocol and in the second spectral band.

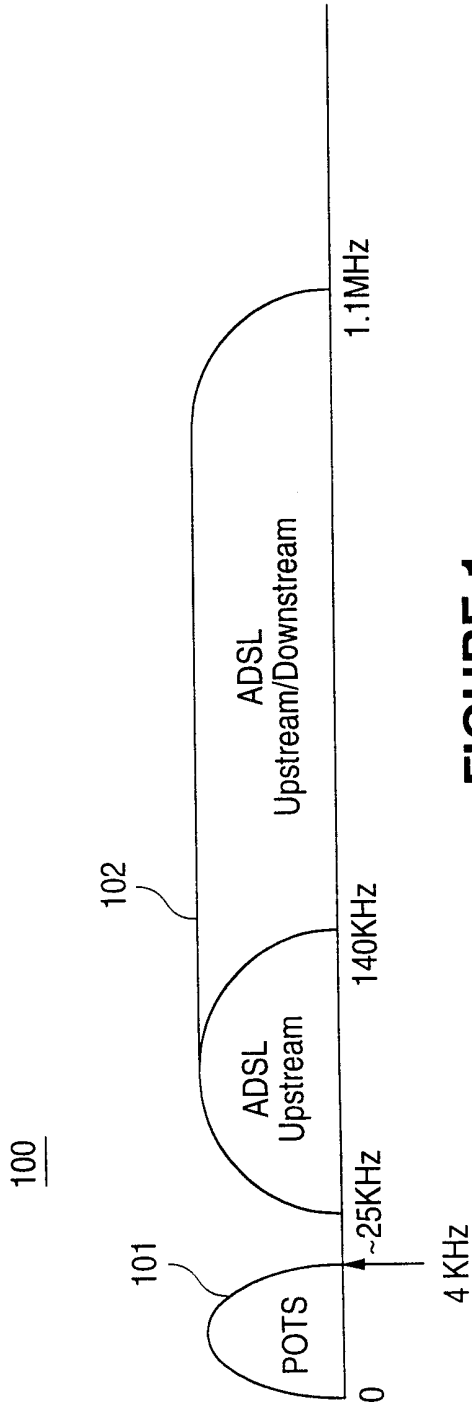

FIGURE 1

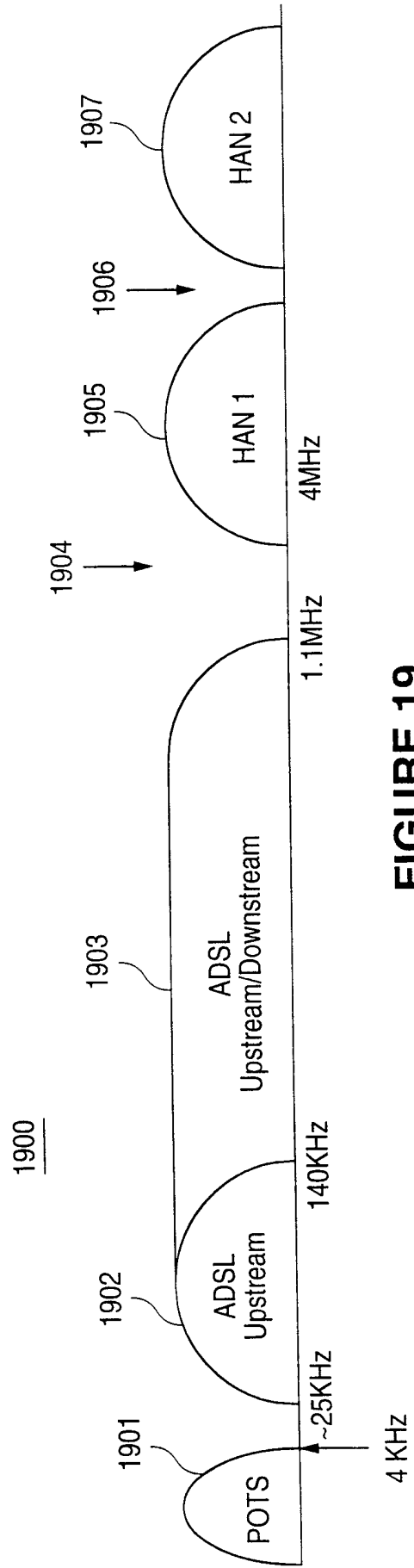

FIGURE 19

2/17

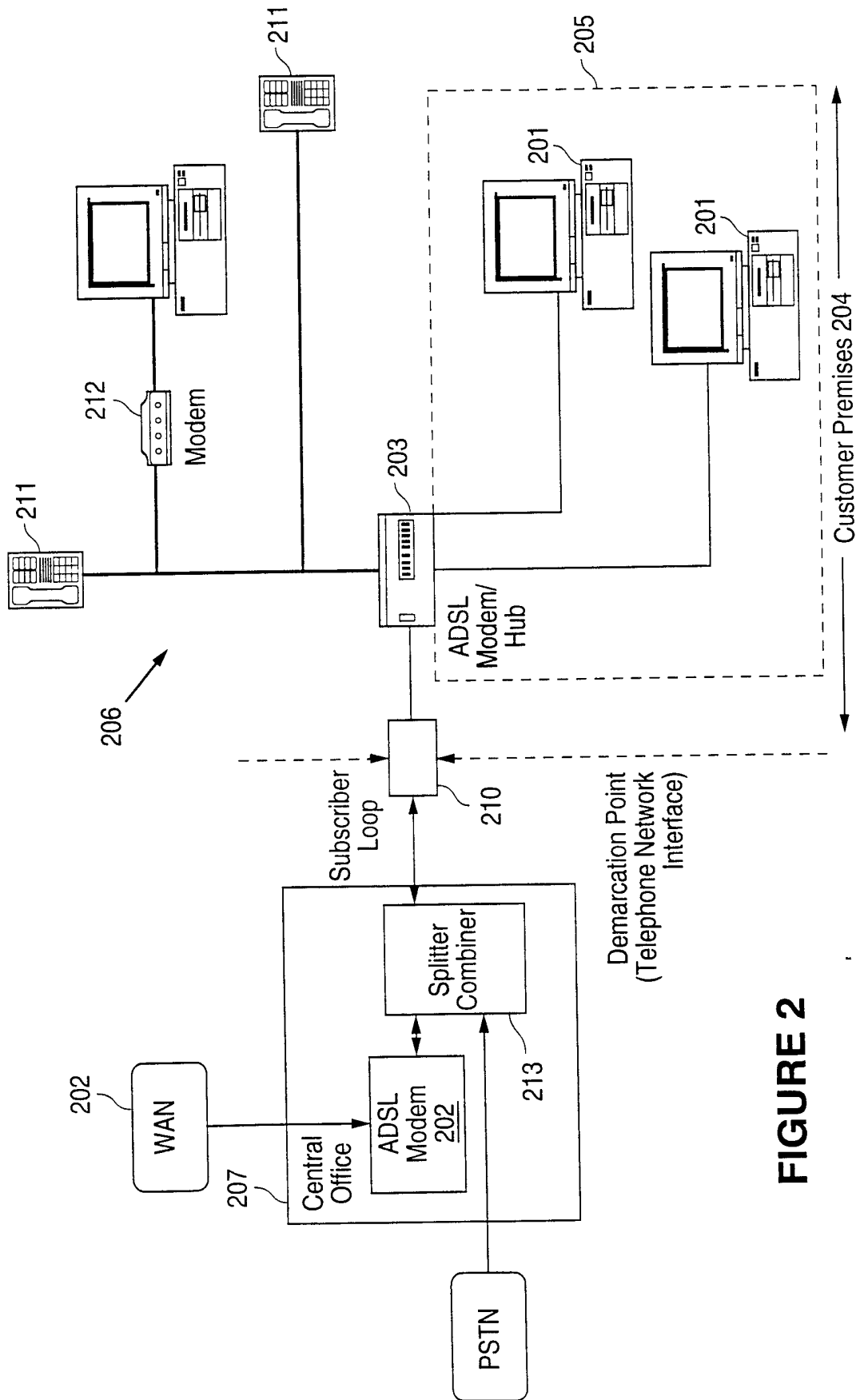

FIGURE 2

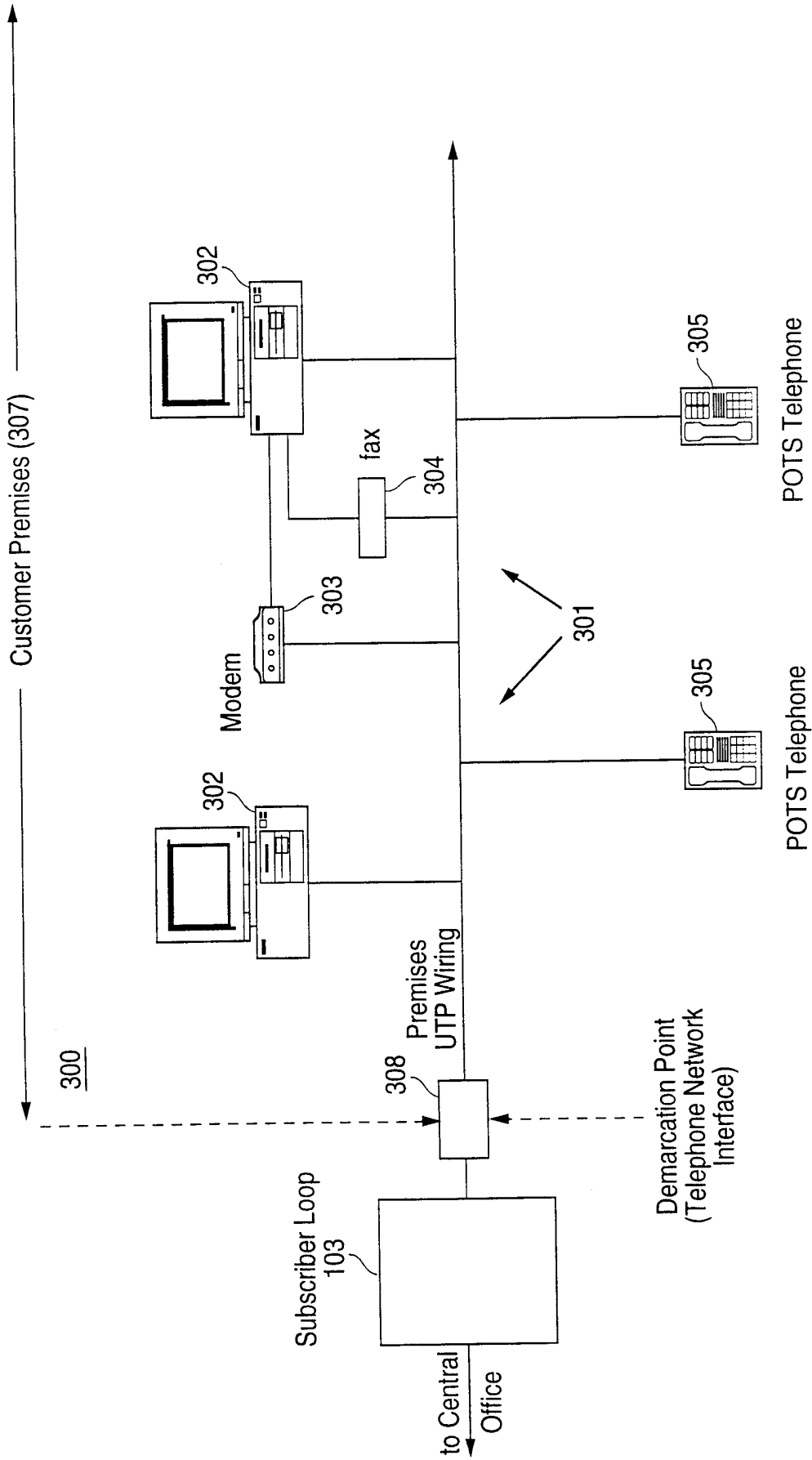

FIGURE 3

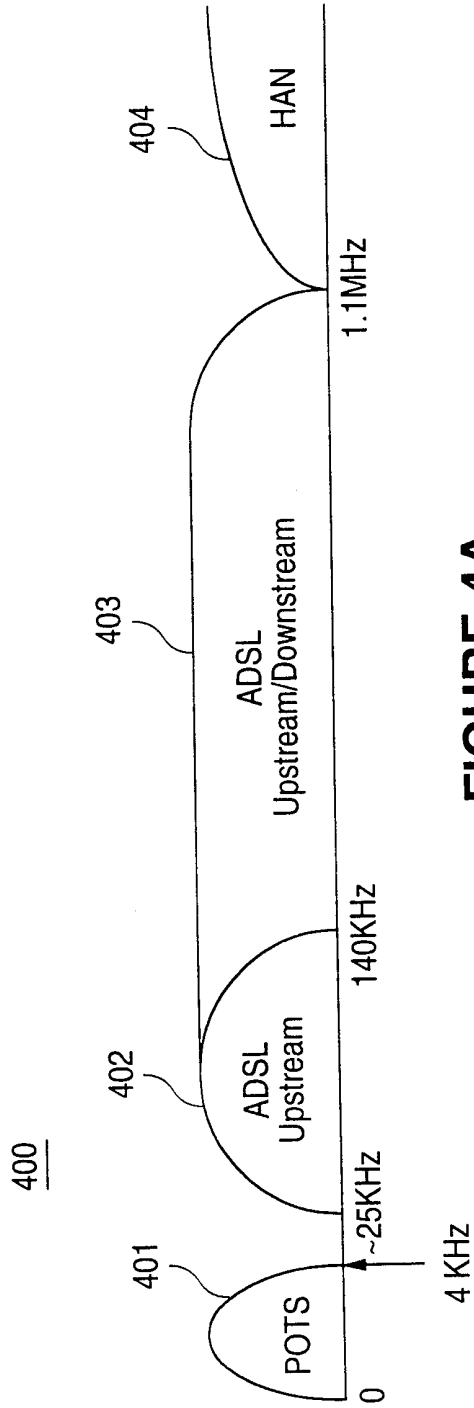

FIGURE 4A

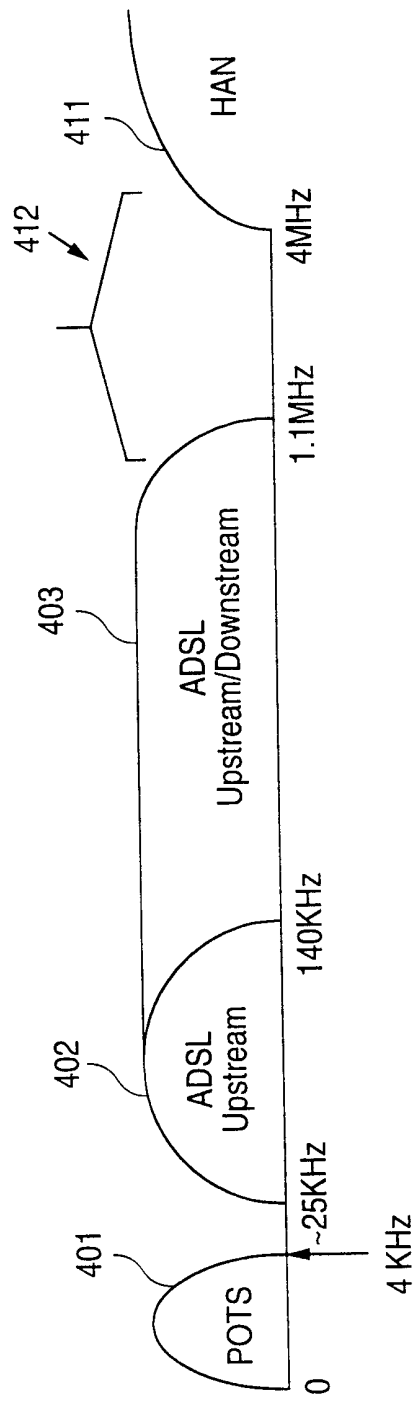

FIGURE 4B

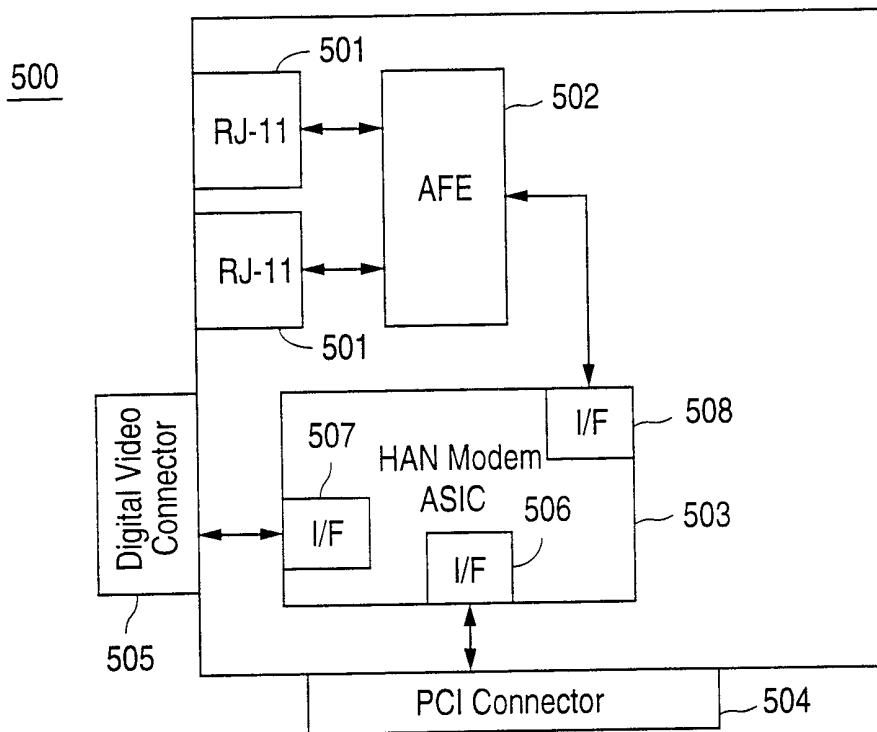

FIGURE 5A

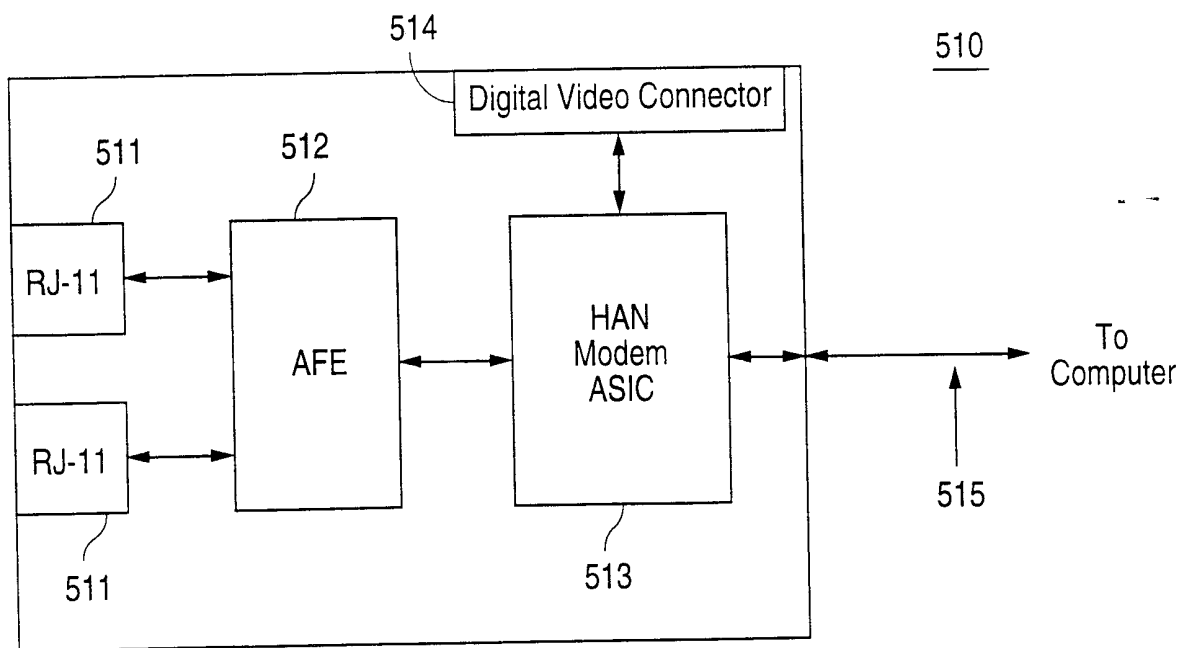
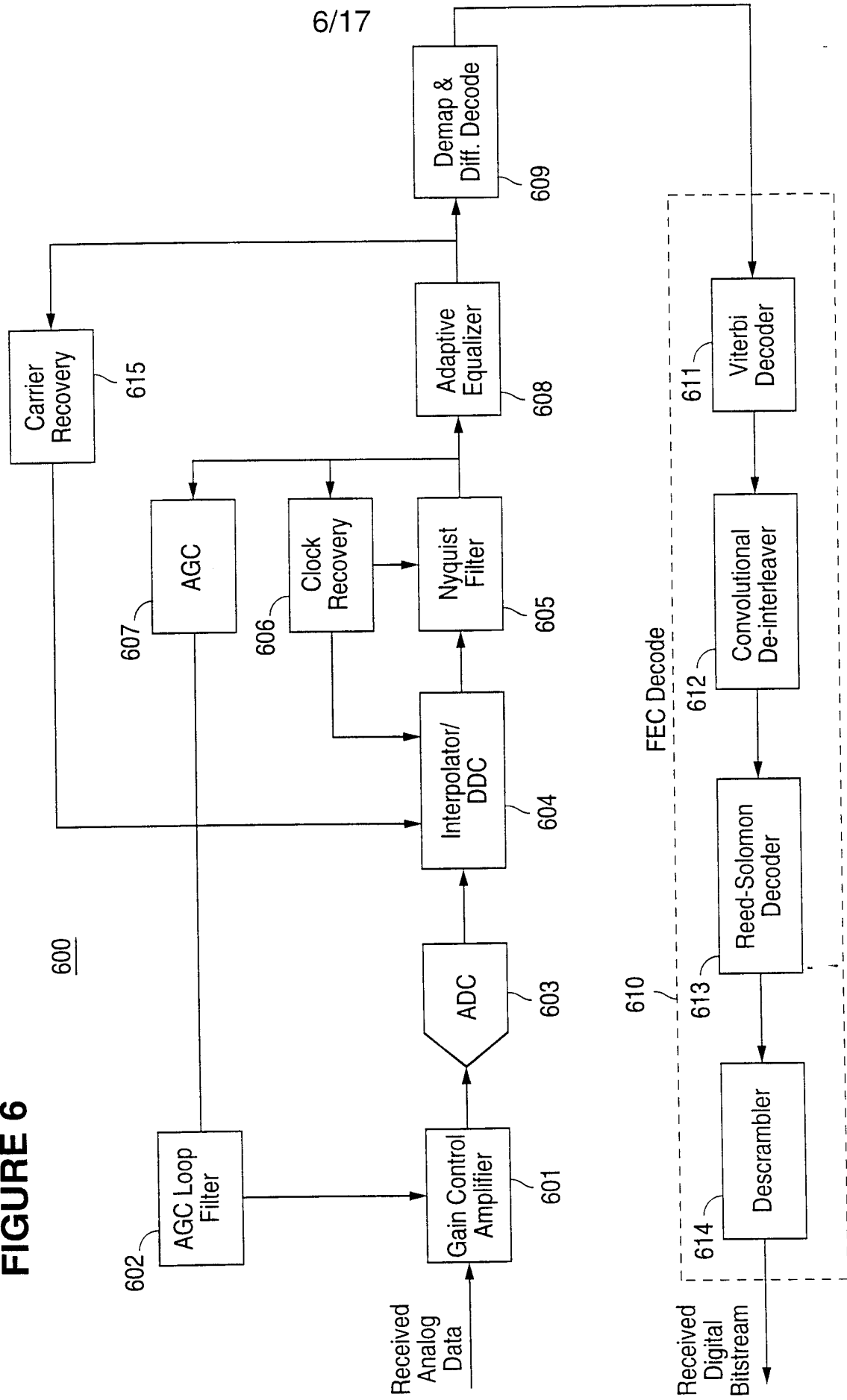

FIGURE 5B

FIGURE 6



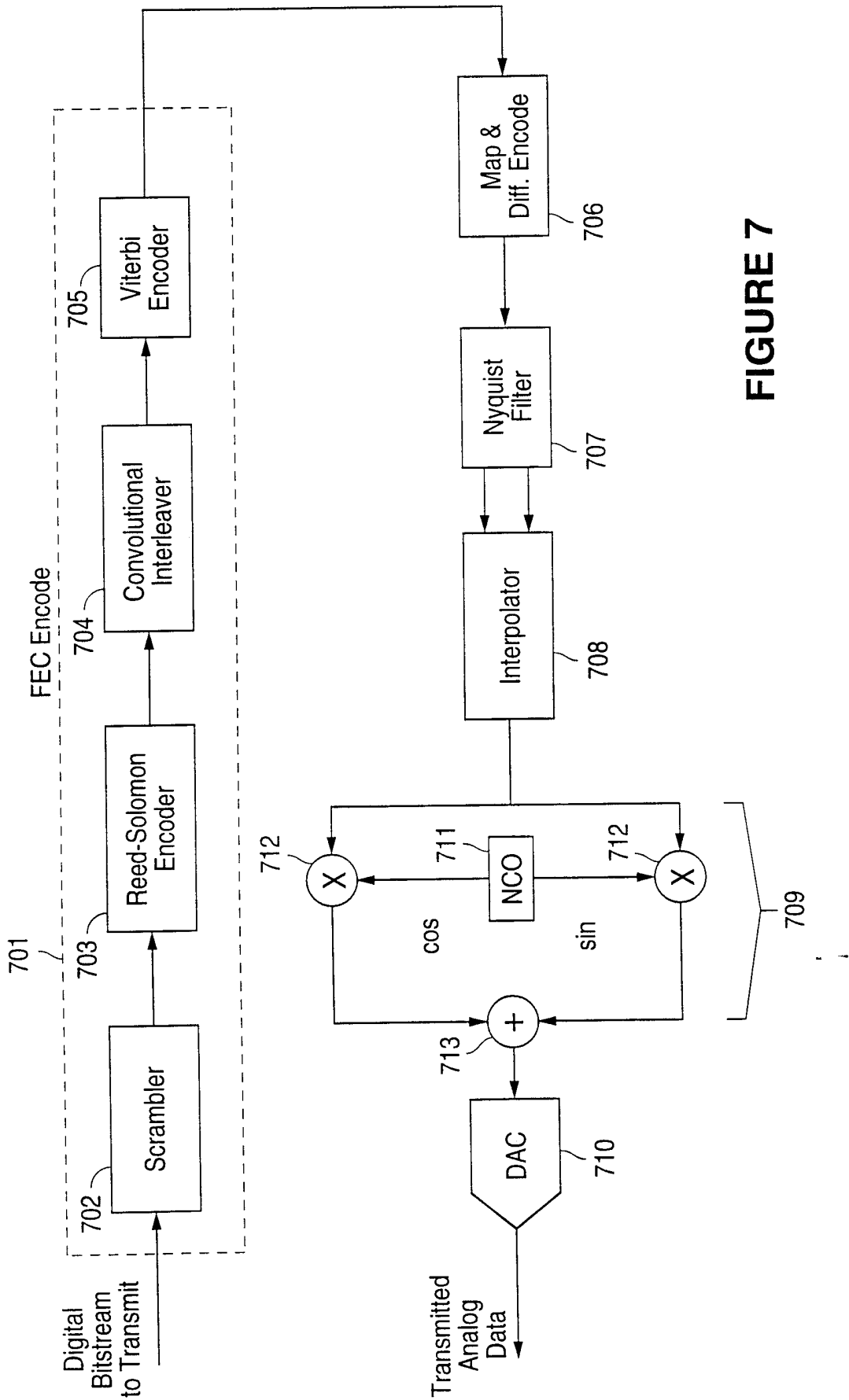

FIGURE 7

8/17

308

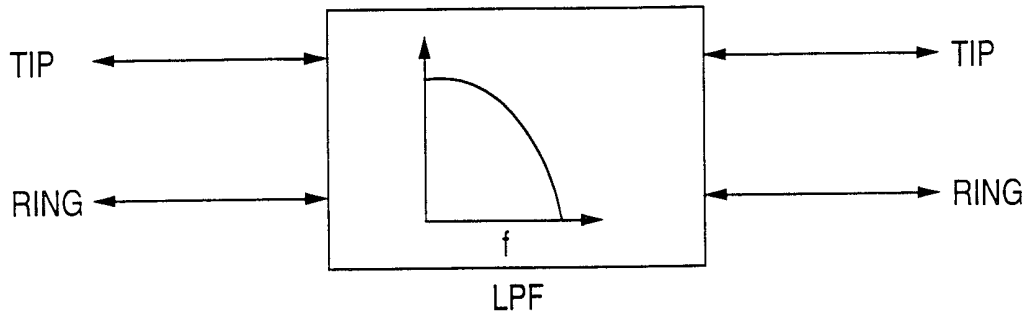

FIGURE 8

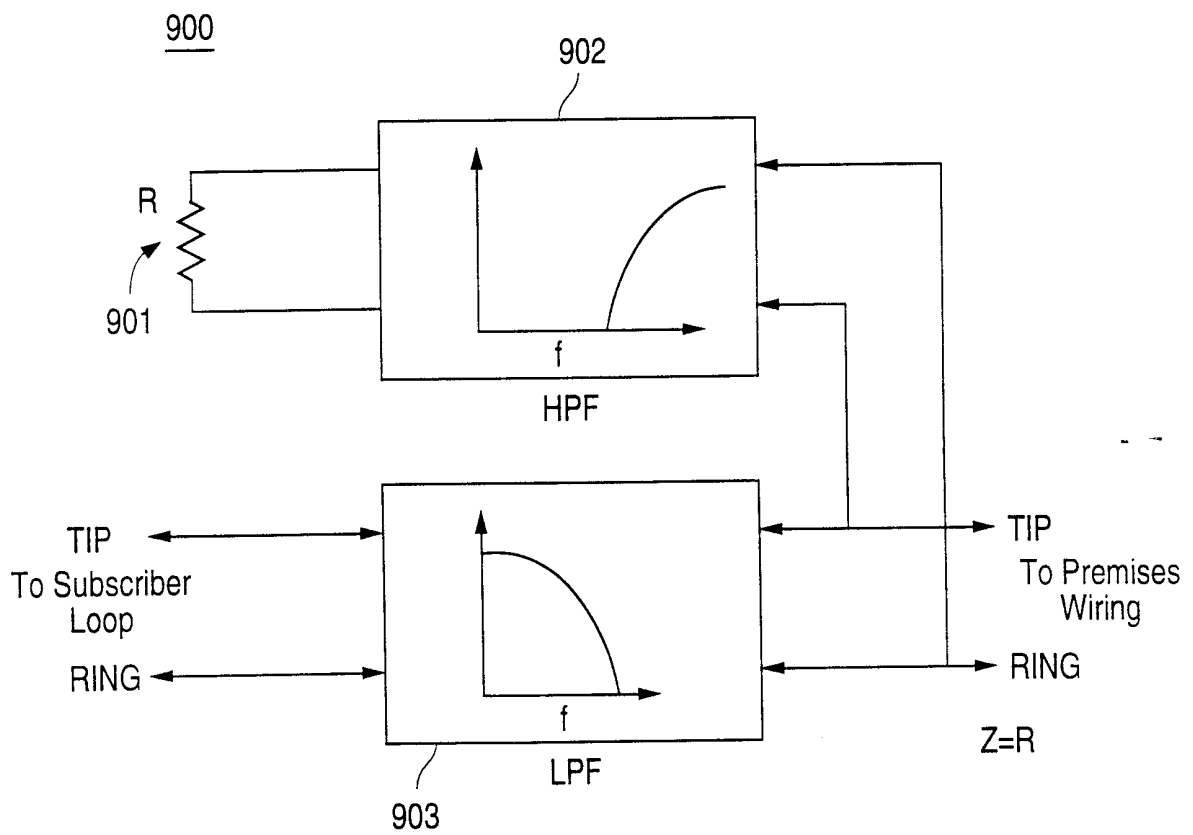

FIGURE 9

9/17

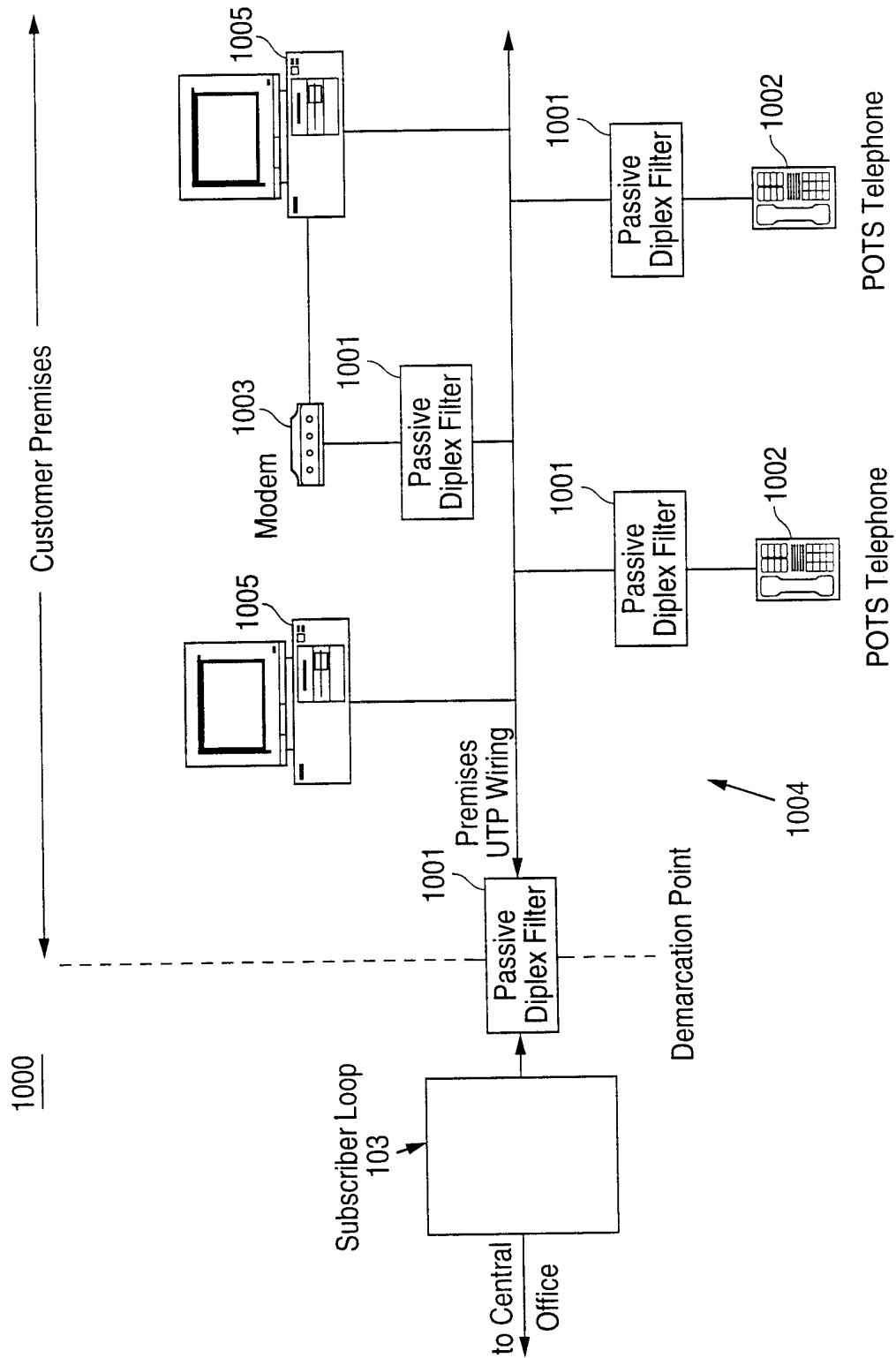

FIGURE 10

10/17

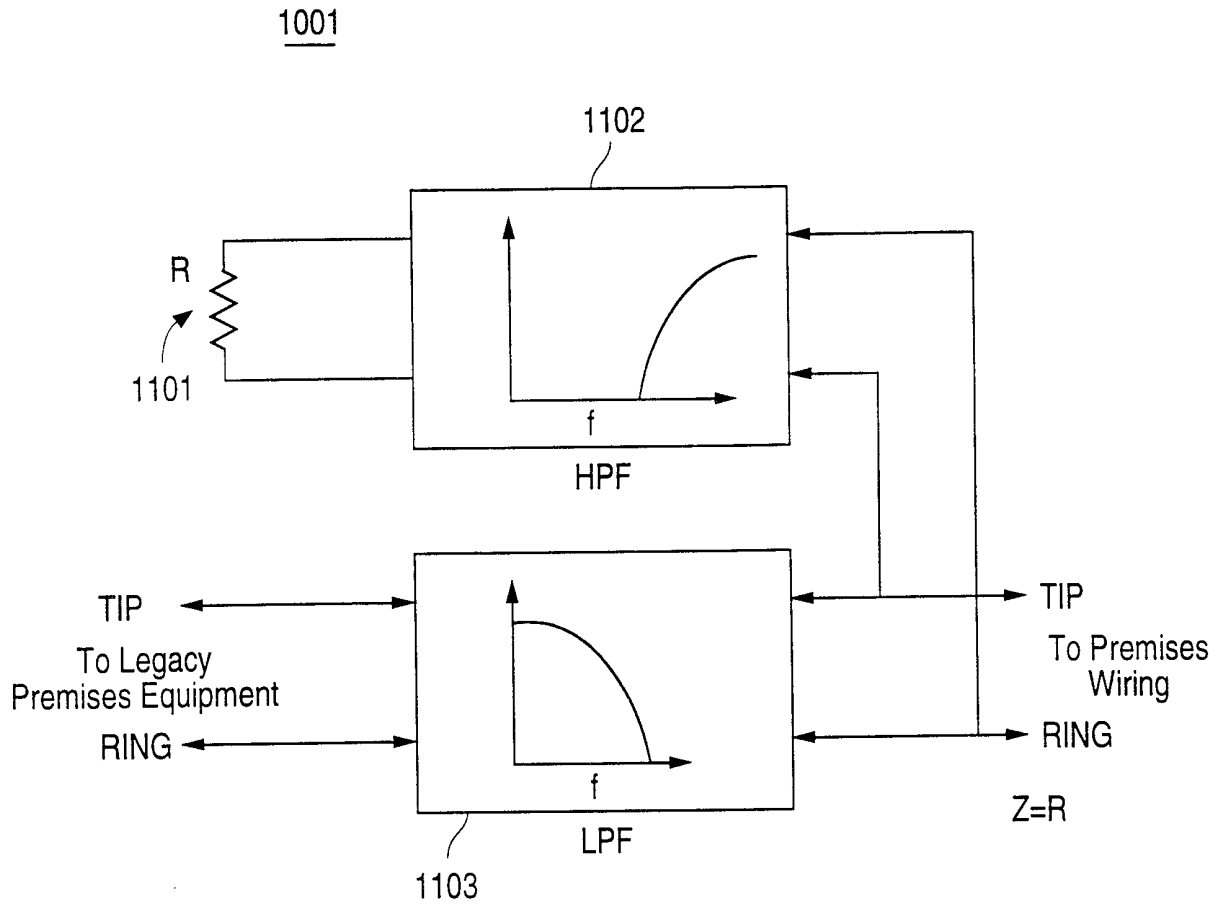

FIGURE 11

11/17

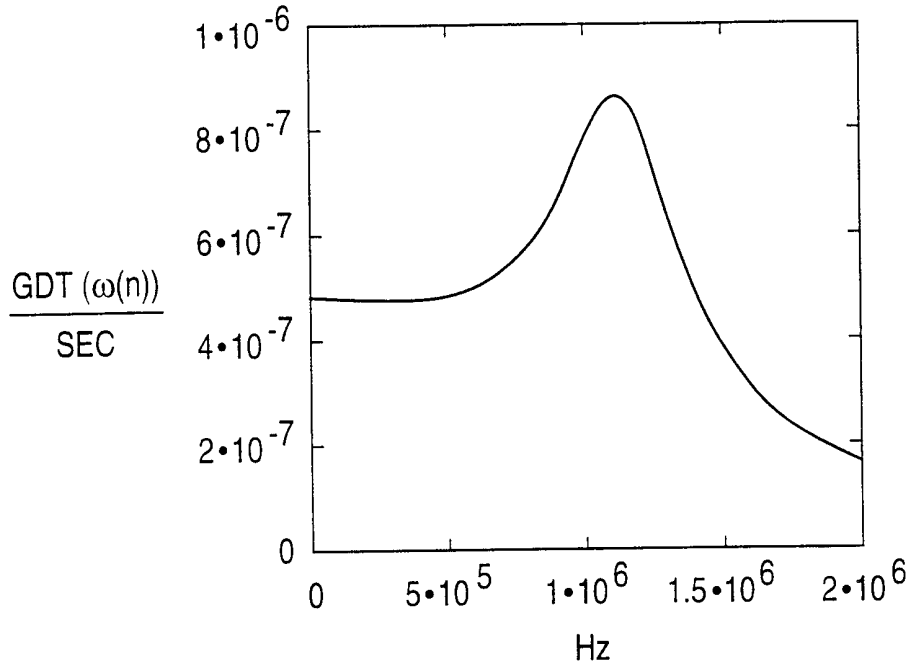

FIGURE 12

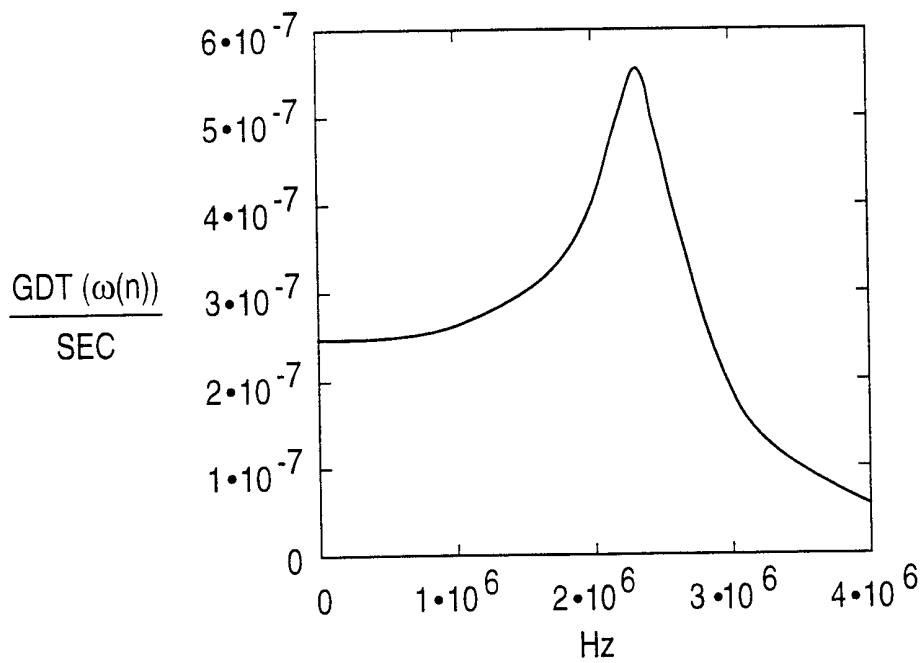

FIGURE 13

12/17

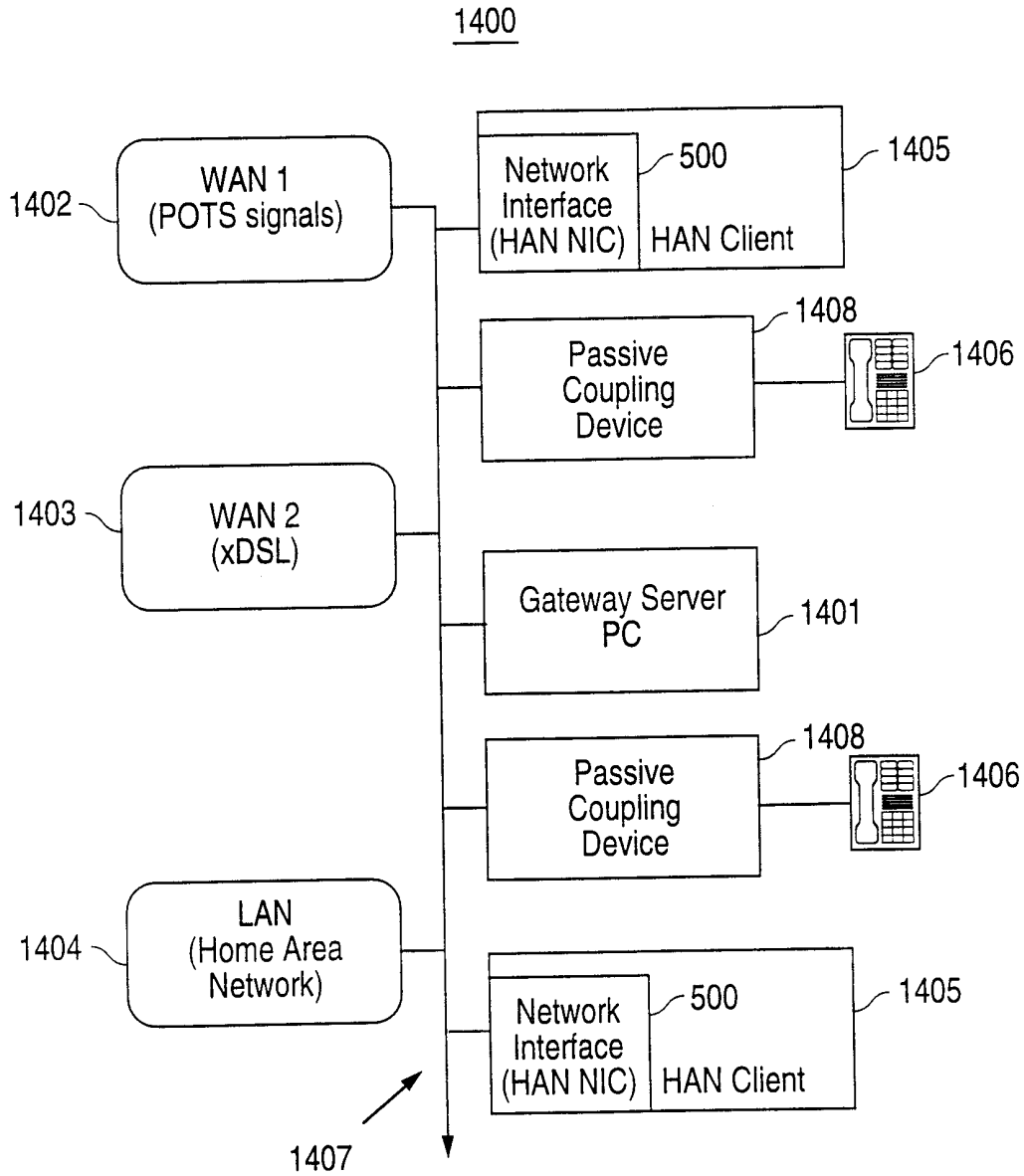

FIGURE 14A

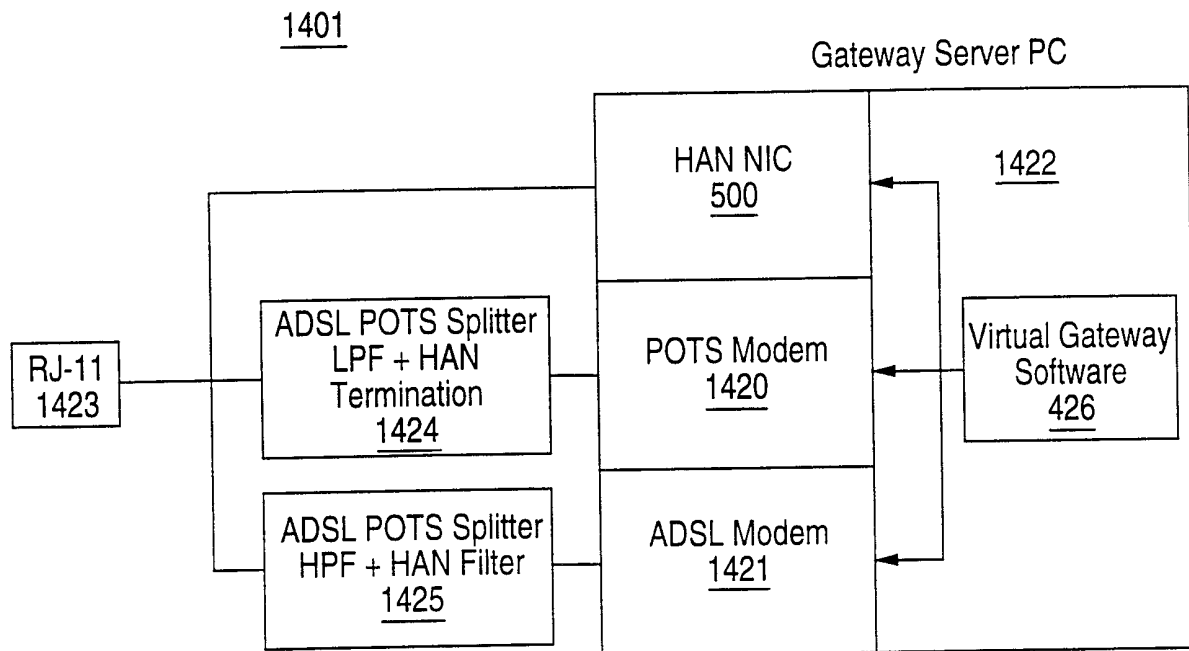

FIGURE 14B

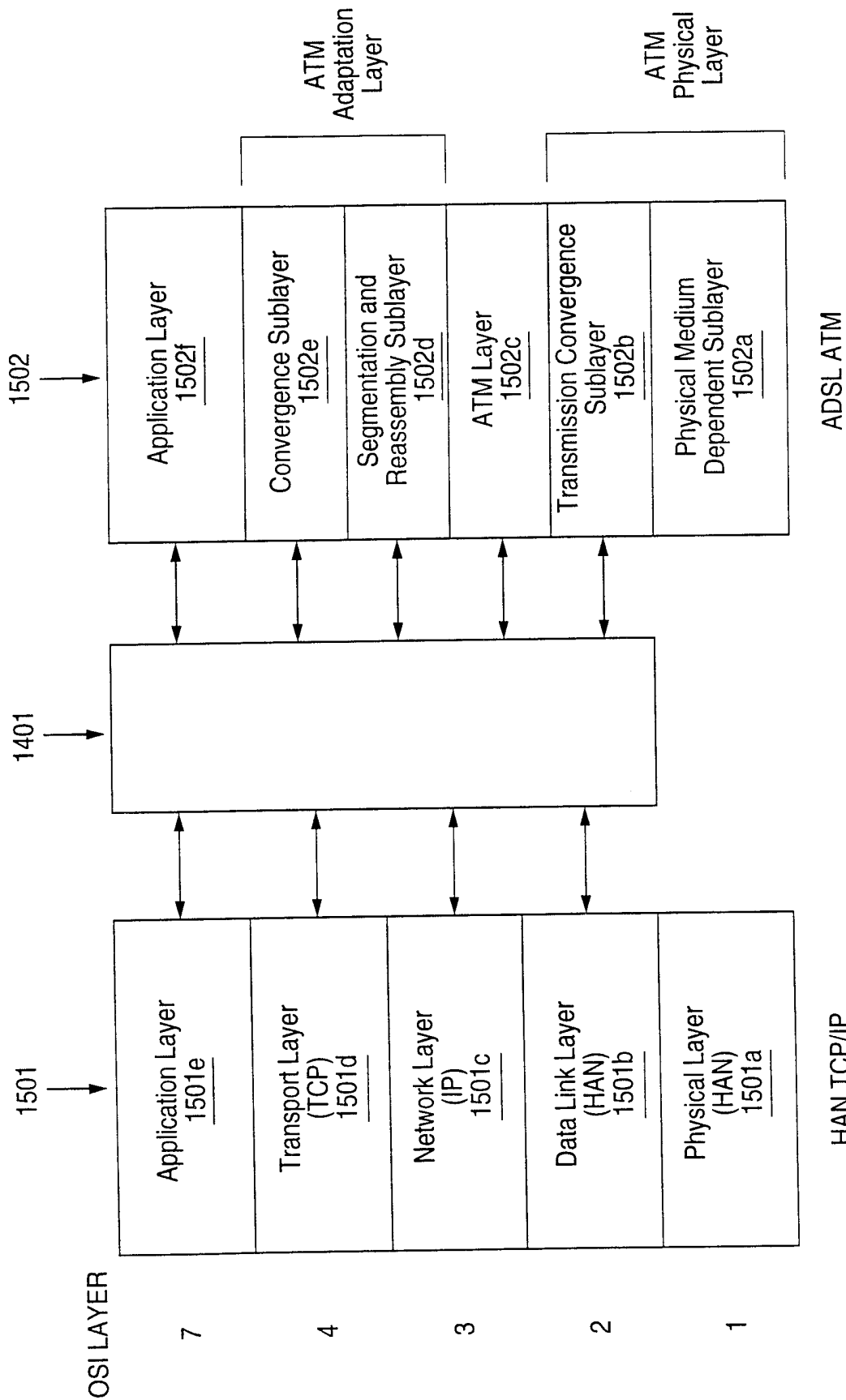

FIGURE 15

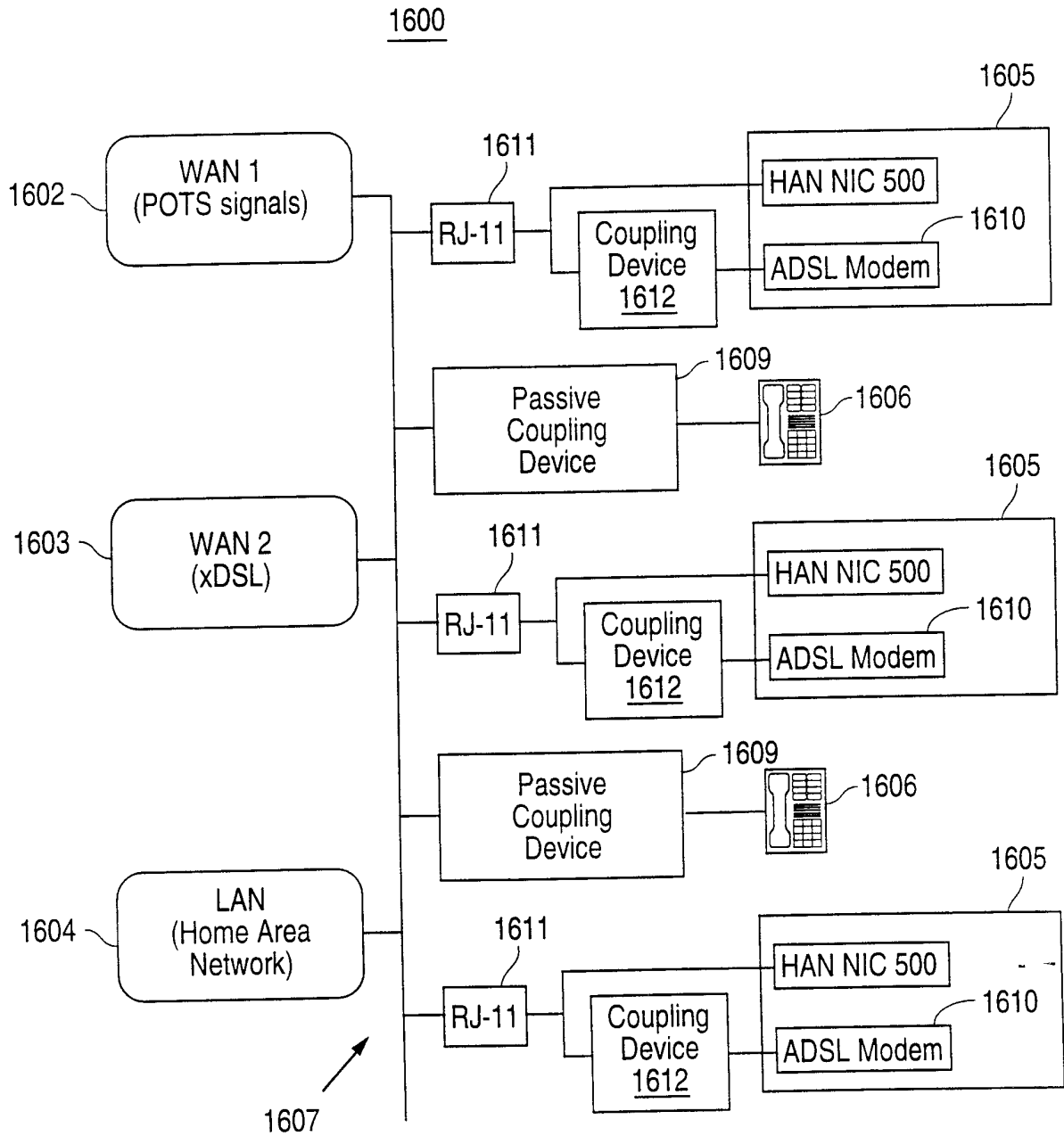

FIGURE 16

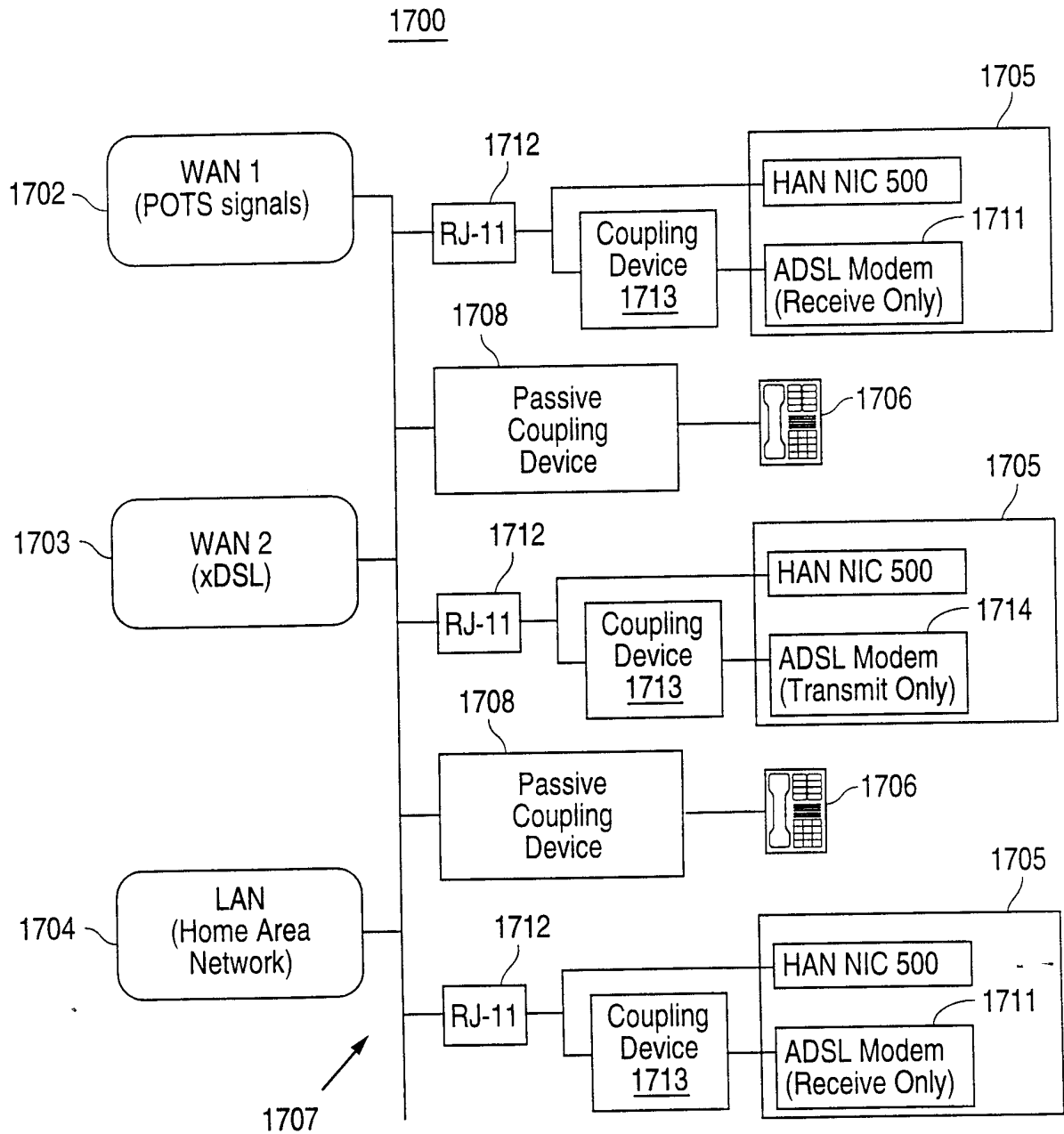

FIGURE 17

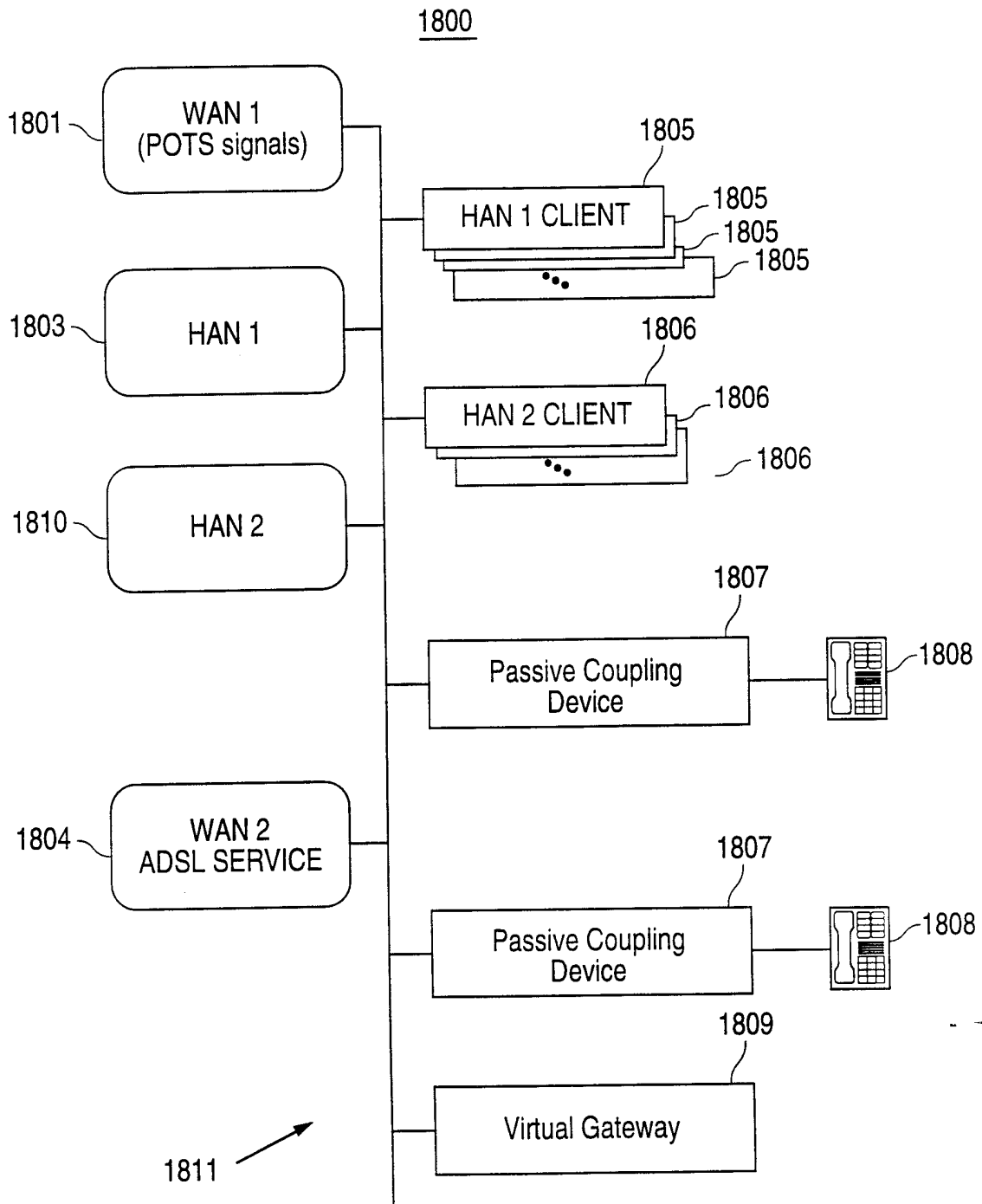

FIGURE 18

INTERNATIONAL SEARCH REPORT

International Application No

PCT/US 98/20921

A. CLASSIFICATION OF SUBJECT MATTER
 IPC 6 H04L12/66 H04L29/06 H04M11/06 H04L5/08

According to International Patent Classification (IPC) or to both national classification and IPC

B. FIELDS SEARCHED

Minimum documentation searched (classification system followed by classification symbols)

IPC 6 H04L H04J H04M

Documentation searched other than minimum documentation to the extent that such documents are included in the fields searched

Electronic data base consulted during the international search (name of data base and, where practical, search terms used)

C. DOCUMENTS CONSIDERED TO BE RELEVANT

Category °	Citation of document, with indication, where appropriate, of the relevant passages	Relevant to claim No.
A	CHOW P S ET AL: "A MULTI-DDROP IN-HOUSE ADSL DISTRIBUTION NETWORK" SERVING HUMANITY THROUGH COMMUNICATIONS. SUPERCOMM/ICC, NEW ORLEANS, MAY 1 - 5, 1994, vol. 1, 1 May 1994, pages 456-460, XP000438957 INSTITUTE OF ELECTRICAL AND ELECTRONICS ENGINEERS see the whole document --- -/--	1-5,8, 11-16, 18, 21-26, 28,31-40

Further documents are listed in the continuation of box C.

Patent family members are listed in annex.

° Special categories of cited documents :

"A" document defining the general state of the art which is not considered to be of particular relevance

"E" earlier document but published on or after the international filing date

"L" document which may throw doubts on priority claim(s) or which is cited to establish the publication date of another citation or other special reason (as specified)

"O" document referring to an oral disclosure, use, exhibition or other means

"P" document published prior to the international filing date but later than the priority date claimed

"T" later document published after the international filing date or priority date and not in conflict with the application but cited to understand the principle or theory underlying the invention

"X" document of particular relevance; the claimed invention cannot be considered novel or cannot be considered to involve an inventive step when the document is taken alone

"Y" document of particular relevance; the claimed invention cannot be considered to involve an inventive step when the document is combined with one or more other such documents, such combination being obvious to a person skilled in the art.

"&" document member of the same patent family

Date of the actual completion of the international search

29 January 1999

Date of mailing of the international search report

08/02/1999

Name and mailing address of the ISA

European Patent Office, P.B. 5818 Patentlaan 2
 NL - 2280 HV Rijswijk
 Tel. (+31-70) 340-2040, Tx. 31 651 epo nl,
 Fax: (+31-70) 340-3016

Authorized officer

Karavassilis, N

INTERNATIONAL SEARCH REPORT

International Application No

PCT/US 98/20921

C.(Continuation) DOCUMENTS CONSIDERED TO BE RELEVANT		
Category	Citation of document, with indication, where appropriate, of the relevant passages	Relevant to claim No.
A	<p>US 4 707 827 A (BIONE ANGELO A ET AL) 17 November 1987</p> <p>see column 2, line 20 - column 3, line 39 see column 4, line 25 - column 5, line 10 see column 5, line 43 - column 6, line 17 ---</p>	<p>1,2,6, 11,12, 16,21, 22,26, 31, 34-36,40</p>
A	<p>EP 0 269 423 A (TYTEL PTY LTD) 1 June 1988</p> <p>see page 2, column 1, line 28 - line 51 see page 3, column 3, line 14 - line 50 see claims 1-4 -----</p>	<p>1,7, 9-11,17, 19-21, 27, 29-31,33</p>

INTERNATIONAL SEARCH REPORT

Information on patent family members

International Application No

PCT/US 98/20921

Patent document cited in search report	Publication date	Patent family member(s)	Publication date
US 4707827 A	17-11-1987	DK 610087 A EP 0261205 A FI 875115 A WO 8705763 A	20-11-1987 30-03-1988 19-11-1987 24-09-1987
EP 0269423 A	01-06-1988	JP 63211997 A	05-09-1988