

(19) **DANMARK**

(10) **DK/EP 3449067 T3**



(12) **Oversættelse af
europæisk patentskrift**

Patent- og
Varemærkestyrelsen

-
- (51) Int.Cl.: **E 04 F 13/08 (2006.01)** **E 04 F 10/08 (2006.01)** **E 04 F 13/10 (2006.01)**
- (45) Oversættelsen bekendtgjort den: **2023-08-14**
- (80) Dato for Den Europæiske Patentmyndigheds bekendtgørelse om meddelelse af patentet: **2023-05-10**
- (86) Europæisk ansøgning nr.: **17721570.4**
- (86) Europæisk indleveringsdag: **2017-04-25**
- (87) Den europæiske ansøgnings publiceringsdag: **2019-03-06**
- (86) International ansøgning nr.: **EP2017059753**
- (87) Internationalt publikationsnr.: **WO2017186694**
- (30) Prioritet: **2016-04-26 EP 16167154**
- (84) Designerede stater: **AL AT BE BG CH CY CZ DE DK EE ES FI FR GB GR HR HU IE IS IT LI LT LU LV MC MK MT NL NO PL PT RO RS SE SI SK SM TR**
- (73) Patenthaver: **NORDISK PROFIL A/S, Amaliegade 6, 1256 København K, Danmark**
- (72) Opfinder: **BITSCH, John, Strandvejen 441, 2930 Klampenborg, Danmark**
- (74) Fuldmægtig i Danmark: **Dragsted Partners A/S, Rådhuspladsen 16, 1550 København V, Danmark**
- (54) Benævnelse: **Lamelfrontoverfladesystem**
- (56) Fremdragne publikationer:
EP-A1- 0 685 614
EP-A1- 2 278 090
WO-A1-2012/035563
WO-A1-2014/068551
BE-A3- 1 020 429
JP-U- H0 583 289
KR-B1- 100 668 113

DESCRIPTION

Field of the invention

[0001] The present invention relates to a lamella front surface system and to use of such lamella front surface system.

Background art

[0002] A number of systems exist for creating a finish of a front surface of a structure, the exterior finish being lamella, жалousies, louveres, blinds or similar and the interior being tapestry or thin wooden boards. Creating such finishing face of a structure, e.g. a building, is often a cumbersome and time-consuming process. When creating a wood finishing face of a structure, the wood is attached directly to the structure by screws or similar. This implies handling long elements and machinery during the actual front surface installation process of e.g. a facade, roof, wall or a ceiling. If a single board or a single wood part deteriorates or otherwise is damaged, it is extremely expensive to repair such individual part and involves a great risk of damaging the neighbouring parts.

[0003] WO2014/068551 discloses a louvered structure including a plurality of slat-structures and at least two beam support profiles. Each of the slat-structures includes at least two slat-connecting- portions, securely attached to the obstructed surface of the slat. The beam support profiles are disposed transversely, relative to the slats, wherein each of the beam support profiles includes a plurality of lateral grooves formed at the front surface of each of the beam support profiles. EP0685614 A1 discloses a system with cladding plates made of mineral material and represents the closest prior art.

Summary on the invention

[0004] It is an object of the present invention to wholly or partly overcome the above disadvantages and drawbacks of the prior art. More specifically, it is an object to provide an improved lamella front surface system having a non-metal face and in which it is easy to install and uninstall individual elements.

[0005] The above objects, together with numerous other objects, advantages, and features, which will become evident from the below description, are accomplished by a solution in accordance with claim 1.

[0006] In this way it is achieved that the mounting process of non-metal lamellae is carried out without tools at a much higher pace and with a greater degree of precision than hitherto

known. The lamellae are the visible part and hence it is highly important to the quality of the final installation that the lamellae are precisely mounted. Furthermore, when no fixation is carried out from the front of the lamella, e.g. by means of screws or nails, the risk of introducing rot or fungus to the lamella is avoided.

[0007] The interfacing means of the first side of the fixation element may comprise at least a first projecting leg projecting from the body of the fixation element, the first projecting leg being configured to connect with the attachment means of the metal mounting element.

[0008] Furthermore, an end part of the at least one first projection leg may comprise an area of increased thickness.

[0009] Moreover, an end part of a first or a second projection leg may comprise an area of increased thickness.

[0010] Also, the attachment means of the metal mounting element may be a separate part affixed to the metal mounting element.

[0011] Furthermore, the attachment means may comprise two projecting attachment arms for engaging with two projecting legs of the fixation element.

[0012] In addition, the attachment means may be a number of slots arranged in the interface side, the slots being configured to receive a first projecting leg of the fixation element.

[0013] The end part of the first projecting leg and a slot of the attachment means constitutes a snap-lock arrangement.

[0014] Moreover, the end part of a projecting leg and a slot of the attachment means may constitute a snap-lock arrangement.

[0015] The first side of the fixation element may comprise a second projecting leg having an end part, the end part of the second projecting leg being in a substantially perpendicular position configured to be lockingly engaged with the attachment means of the metal mounting element.

[0016] Further, the fixation means may extend substantially along the full length of the longitudinal extension of the non-metal lamella.

[0017] Also, the lamella may be made of wood, wood fibre composites, glass or composites such as compact rock or compact marble.

[0018] Additionally, the longitudinal extension of the lamella may be different from a length of the fixation element.

[0019] In one embodiment, the fixation element may be made of metal.

[0020] Moreover, the longitudinal extension of the lamella may be more than 5 mm longer than the longitudinal extension of the fixation element.

[0021] The longitudinal extension of the lamella may be longer than the longitudinal extension of the fixation element by 10-100 mm or more.

[0022] Furthermore, the fixation element may be 890-990 mm and the lamella may be 990-1010 mm.

[0023] Also, the metal mounting element may have a surface, the surface being treated e.g. by eloxation, anodization or painted.

[0024] Further, when inserting the end part of the first projection leg from a position in which the first projecting leg, and thereby the fixation element as a whole, may be tilted by more than 5° and less than 80° from perpendicular to the mounting element, the end part of the first projecting leg of the fixation element may be inserted into the attachment means of the mounting element substantially without touching each other, and upon tilting to a position different from approximately 5°-80°, they may be arranged to be lockingly engaged.

[0025] Both the first projecting leg and the second projecting leg may comprise an end part having an increased thickness.

[0026] Additionally, the fixation element may comprise at least one alignment projection extending from the side of the body opposite the side from which the at least one first projecting leg extends. In one embodiment, the alignment projection may be configured to support the lamella. In this way it is achieved that the effect of the living nature of wooden lamella, i.e. the changes in shape due to changes in temperature or humidity, is minimised. As an example, the lamellae are likely to curve when the humidity is changing but they are kept in position by the alignment projection(s).

[0027] The alignment projection(s) may have a substantially triangular cross section. Further, the alignment projection(s) may have a substantially semi-circular cross section. Also, the alignment projection(s) may have a rectangular cross section.

[0028] The lamella may be attached or affixed to the fixation element in a manner in which only one surface is in contact with the fixation element, e.g. one face of a lamella having a square cross section or the substantially flat surface of a semicircular cross section.

[0029] In this way it is possible to ensure that the lamella follows the longitudinal extension of the fixation element, i.e. that the longitudinal axis of the lamella is substantially parallel with the longitudinal axis of the alignment projection(s).

[0030] The alignment projection may extend in the full length of the fixation element. In this way it is possible to manufacture the fixation element by extrusion, e.g. in aluminium.

[0031] The alignment projection may be broken along the length of fixation element. In this way it is possible to form the fixation element and the alignment projection(s) by rolling, folding or other shaping processes.

[0032] The alignment projection may be arranged so as to project into a groove in the lamella. The alignment projection may be arranged so as to abut a part of an outer surface of the lamella.

[0033] Also, the first projecting leg may have a first extension and the second projecting leg may have a second extension, the first and second extensions being 5-100 mm, more preferred 7.5-75 mm, or even more preferred 10-50 mm.

[0034] Furthermore, the projecting legs may extend approximately 15 mm from the body.

[0035] Moreover, the extensions of the first and second projecting legs may be identical.

[0036] In addition, the extensions of the first and second projecting legs may be different from each other.

[0037] Both the first and the second projecting legs may comprise an end part of increased thickness.

[0038] The first projecting leg and the second projecting leg of the fixation member may be flexible in such way that the distance between the first and second projecting legs may be increased or decreased during mounting of the fixation element with the mounting element.

[0039] In this way it is achieved that the end parts and thereby the fixation element may be lockingly engaged as a snap-lock function. The second leg and/or the first leg may be sufficiently flexible in order for the end part having an increased thickness to be pushed past a part on the mounting element in order to regain the initial position, whereby the fixation element and the mounting element are locked together.

[0040] In an embodiment, the fixation element may be made from a flexible material such as a spring steel or spring strip steel. In this way it is possible to create easily accessible areas behind a section of the lamella system, e.g. for inspection purposes.

[0041] Further, the at least one alignment projection may have an outer surface, the outer surface being substantially even with an outer surface of the lamella.

[0042] Moreover, the lamella may comprise areas of reduced thickness in order to fit between two projecting legs of the fixation element.

[0043] In this way it is achieved that the outer surface and the fixation element form a substantially even surface.

[0044] Also, the lamella may be surface-treated, e.g. by paint or oil.

[0045] In a particular embodiment, the lamella is acetylate-treated wood, e.g. known under the brand name Accoya.

[0046] Furthermore, the lamella may be affixed to the fixation element by screws.

[0047] The body of the fixation element may comprise a number of apertures.

[0048] Additionally, the body of the fixation element may comprise apertures, the apertures being 2-20 mm or 3-15 mm or 4-10 mm, or more preferred 5 mm, and a number of the apertures may be elongated apertures.

[0049] A number of the apertures may be elongated apertures.

[0050] In this way it is possible for the lamella to expand or contract, i.e. extend or contract differently from the fixation element due to changes in temperature and humidity in the surrounding environment.

[0051] Moreover, the elongated apertures may have a longitudinal extension of 7.5-50 mm or 10-40 mm or 12.5-30 mm, or more preferred 15-20 mm.

[0052] Furthermore, the lamella front surface system may comprise a number of fixation parts. In this way it is possible to fix the fixation element to a mounting element in a controlled manner, i.e. either to allow for movement of the fixation element relative to the mounting element in a perpendicular direction along the longitudinal axis of the fixation element, or to fix the fixation element relative to the mounting element in a perpendicular direction along the longitudinal axis of the fixation element. Hence, it is possible to achieve a point with substantially no longitudinal movement due to humidity or temperature i.e. a "movement 0-point" and let the movement start from there. The movement is typically caused by changes in temperature and humidity. Since the movement is caused by changes in temperature, the fixation part may be said to provide "a fixation point" in relation to thermal changes.

[0053] Also, the lamella front surface system may comprise a plurality of mounting metal elements, each being mounted to the face with a distance between them and a plurality of fixation elements supporting a plurality of lamellae.

[0054] In an embodiment, the fixation element may comprise a lip arranged to close the gap between two abutting fixation elements. In this way it is achieved that the fixation elements form a substantially closed face protecting the surface behind e.g. a wall or sealing.

[0055] The substantial vertical face may be part of a wall of a building or may be part of a vertical beam or post.

[0056] The present invention also relates to use of the lamella front surface system as described above for at least partially covering a structure such as a building or a part of a building.

[0057] The present invention also relates to a building comprising a lamella front surface system as described above.

[0058] Further, the present invention relates to a method for creating a front surface covering a structure with non-metallic lamellae.

Brief description of the drawings

[0059] The invention and its many advantages will be described in more detail below with reference to the accompanying schematic drawings, which for the purpose of illustration show some non-limiting embodiments and in which

Fig. 1 shows a lamella front surface system according to the invention,

Fig. 2 shows an exploded view of the components of the lamella system of Fig. 1,

Fig. 3 shows a cross-sectional view of the lamella mounted on a fixation element,

Figs. 4A-E show different embodiments of the fixation element,

Fig. 4F shows the flexibility of the projecting legs of the fixation element,

Fig. 4G shows a further embodiment of the fixation element,

Fig. 4H shows a further embodiment of the fixation element,

Fig. 5 shows the mounting process of fixating the lamella on a mounting element seen from the end of the lamella, i.e. the side of the mounting element,

Figs. 6A-D show, in a cross-sectional view, further embodiments of the profile of the lamella,

Figs. 7A and 7B each show a part of a fixation element comprising apertures,

Fig. 8A shows a fixation part,

Fig. 8B shows a further fixation part,

Figs. 9A-C show the steps of mounting the fixation part shown in Fig. 8A,

Figs. 10A-C show the steps of mounting fixation part shown in Fig 8B,

Figs. 11A-11D show, in cross-sectional views, embodiments of fixation elements having more than one lamella,

Fig. 12 shows the embodiment of Fig. 11C comprising wooden lamellae,

Fig. 13 shows an embodiment of the system comprising a further embodiment of the mounting elements, and

Fig. 14 shows a detailed cross-sectional view of the mounting element shown in Fig. 13.

[0060] All the figures are highly schematic and not necessarily to scale, and they show only those parts which are necessary in order to elucidate the invention, other parts being omitted or merely suggested.

Detailed description of the invention

[0061] Fig. 1 shows a lamella front surface system 1. In this figure, the system is shown comprising five non-metal lamellae 2 and three metal mounting elements 3. The mounting elements 3 have a mounting axis MA. The mounting elements 3 are attached to a support 4, in this case a face 4 of a building. The lamellae 2 have a longitudinal axis LA. In this embodiment, the mounting axis MA of the metal mounting element 3 is substantially perpendicular to the longitudinal axis LA of the lamellae 2. The lamellae 2 are connected with the metal mounting elements 3 by a fixation element 5 (shown in greater detail below).

[0062] It will be understood that the lamella front surface system could comprise a plurality of mounting metal elements, each being mounted to the face with a distance between them and a plurality of fixation elements supporting a plurality of lamellae. The extension of the metal mounting elements and the lamellae and fixation elements may be up to 6000 mm or even more.

[0063] Fig. 2 shows the lamella front surface system 1 of Fig. 1 in an exploded view. Each of the metal mounting elements 3 comprises a mounting side 6 abutting the face 4 of the building. The mounting element 3 further comprises an interfacing side 7 opposing the mounting side 6. The interfacing side 7 comprises attachment means 8. In this embodiment, the attachment means on the mounting element 3 is a number of slots or grooves (only a few are numbered with reference numerals). Only one lamella 2 is shown. However, it will be understood that the system may be expanded to comprise an infinite number of elements and lamellae. The lamella 2 is attached with the metal mounting element 3 via the fixation element 5 having a longitudinal axis FA and hence a longitudinal extension. The fixation element 5 comprises a body 9 having a first side 10 and a second side 11. The first side 10 comprises interfacing means, i.e. projecting legs 12, 13. In this embodiment, the interfacing means comprises a first projecting leg 12 and a second projecting leg 13. The projecting legs 12, 13 are configured to

be connected with the attachment means 8, i.e. the slots or grooves 8 of the interface side 7 of the mounting element 3. The second side 11 of the body 9 of the fixation element 5 is configured to support the lamella 2 along the longitudinal axis of the fixation element FA in order to keep the longitudinal axis LA of the lamella 2 in a substantially parallel position. In this way the lamella 2 is kept in a position which is substantially perpendicular to the mounting axis MA of the metal mounting elements 3. The second side 11 of the fixation element 5 comprises a first alignment projection 14 and a second alignment projection 15. The alignment projections 14, 15 project from the second side 11 of the body 9 of the fixation element 5. The alignment projections 14, 15 are arranged to be inserted into slots 16, 17 in the lamella 2. In this way it is achieved that the lamella 2 is kept in a position which is substantially parallel to the fixation element 5, and in this embodiment furthermore substantially perpendicular to the mounting elements 3. According to the invention the lamella 2 is affixed to the fixation element 5 by means of screws. In this embodiment, the lamella is made of wood but may be made from various kinds of non-metal material, such as wood fibre composites, rock, glass or fibre glass.

[0064] The longitudinal extension of the lamella 2 is different from a length of the fixation element 5. In this way it is achieved that the lamella and the fixation element may expand or contract differently. If the lamella 2 is made of e.g. wood and the fixation element is made of aluminium, their respective elongation due to changes in temperature is different. Furthermore, wood typically expands due to an increase in humidity in the air which aluminium does not, and hence a change in humidity is likely to cause the lamella to increase in length compared to the fixation element. The metal mounting element and the fixation element may be made of a number of metals such as aluminium, alloys of aluminium and at least one other metal or stainless steel.

[0065] Furthermore, lock projections 90 are shown in each side of the mounting element 3 extending in a plane substantially parallel to the mounting side 6 of the mounting element 3. The lock projections will be described further in Figs. 8, 9 and 10. In the embodiments shown in Fig. 1 and Fig. 2, the longitudinal extension of the lamella 2 is more than 5 mm longer than the longitudinal extension of the fixation element. In this embodiment, the fixation element 5 is 890-990 mm and the lamella 2 is 990-1010 mm.

[0066] In this embodiment, the projecting legs extend approximately 15 mm from the body.

[0067] Fig. 3 shows a part of a lamella front surface system 1 seen from the side. The lamella 2 is connected with the mounting element 3 via the fixation element 5. It is seen that the projecting legs 12, 13 comprise end parts 22, 23 with an increased thickness. The end parts 22, 23 having an increased thickness facilitates that the fixation element 5 can be lockingly engaged with the mounting element 3. The grooves 8 in the mounting element 3 comprise a projection 24 which the end part 22, 23 need to pass when inserted in the groove 8. In this way, a simple and reliable snap lock function is obtained. The mounting process of the fixation element 5 with the mounting element 3 is described below in Fig. 5. Fig. 3 shows three embodiments of the fixation element 5. The attachment of the lamella 2 to the fixation element 5 is carried out using screws.

[0068] Figs. 4A-4D show different embodiments of the fixation element 5 having the same lamella 2 connected thereto.

[0069] Fig. 4A shows an end view of an embodiment of the fixation element 5 having a lamella 2 affixed thereto. In this embodiment, the fixation element comprises one projecting leg 12, the projecting leg having an end part 22 with an increased thickness. The increased thickness extends to both sides of the projecting leg 12. In this way, after the fixation element 5 has been connected to the mounting element, the fixation element is locked in the direction of the arrow F (the mounting process is shown below in Fig. 5). When mounted, the fixation element 5 and therefore the lamella 2 may be positioned in a tilted position. In this way, e.g. the top surface 40 may be arranged parallel to the projection leg 12 but be arranged slanting. The slanted top surface 40 provides the possibility of leading e.g. rain water etc. away from the back mounting element 4 and typically the face of the structure. The lamella 2 may be arranged to compensate for this tilted position. In this way, the front surface 41 may still be arranged substantially parallel to the mounting element and the face of the structure (seen e.g. in Fig. 3). In this embodiment, the fixation element 5 comprises two alignment projections 16, 17 extending from the body 9 of the fixation element 5. The lamella 2 is affixed to the fixation element 5 by a screw 18. The screw 18 ensures that the lamella 2 is drawn towards an alignment surface 44 of the body 9. The screw(s) 18 may be arranged in elongated apertures. The alignment projections 14, 15 are inserted in the alignment slots 16, 17 arranged in the lamella 2. The slots 16, 17 may be filled with an elastomer or glue material.

[0070] Fig. 4B shows an embodiment of the fixation element 5. In this embodiment, the fixation element 5 comprises one alignment projection 14 which is inserted in one alignment slot 16. It will be understood by the skilled person that the alignment projection 14 could be arranged projecting anywhere along the body 9. If the alignment projection 14 is arranged at the middle of the body 9, the screw 18 would be moved accordingly to either the one or the other side of the alignment projection. It is seen that the top surface 40 of the lamella 2 and the front surface 41 are arranged similar to the embodiment shown in Fig. 4A, and hence it will be understood that the fixation element may take various shapes and still maintain the same appearance as the lamella 2.

[0071] Fig. 4C shows an embodiment of the fixation element 5 which is also seen in Figs. 1-3. Fig. 4C shows that the fixation element 5 comprises a first projecting leg 12 and a second projection leg 13 as well as a first alignment projection 14 and a second alignment projection 15. The end parts 22, 23 of the projecting legs 12, 13 are different from each other. The end part 22 has an increased thickness so that the increase in thickness projects both away and towards the end part of the second projecting leg 13. The increase in thickness of the second end part 23 of the second projecting leg only projects towards the first projecting leg 12. The first projecting leg 12 is similar to those shown in Figs. 1-3, 4, 4A and 4B.

[0072] Fig. 4D shows a further embodiment of the fixation element 5. In this embodiment, the first and the second projection legs 12, 13 of the fixation element 5 comprise end parts having

a similar increased thickness. The increase in thickness of each of the end parts 22, 23 of the projecting legs is arranged in a way that the increase of the one end part projects towards the other end part, i.e. the end parts have opposing projecting areas. Hence, the increase in thickness is a projection along the longitudinal axis FA of the fixation element 5. In this embodiment, it is possible to attach the fixation element 5 and hence the lamella 2 to the mounting element directly in the direction of the arrow MD to the mounting element (not shown). This makes it possible to mount the lamellae 2 close to each other or have larger lamellae 2. It will be understood by the skilled person that this embodiment of the projecting legs of the fixation element 5 may be applied to all embodiments of the fixation element comprising a first and a second projecting leg.

[0073] The attachment means of the metal mounting element, i.e. the grooves 8, may in another embodiment be a separate part affixed to the metal mounting element.

[0074] The separate part may comprise two projecting arms configured to receive the projecting legs of the fixation element 5. Such projecting arms are arranged to receive and lockingly engage with projecting legs as shown in both Figs. 4C and 4D. The separate part may have a shorter extension along the longitudinal axis LA of the fixation part 5.

[0075] Fig. 4E shows another embodiment of the lamella 2 and the fixation element 5. In this embodiment, the alignment projections 14, 15 is substantially even with the top surface 40 of the lamella and bottom surface 42 of the lamella 2. In this embodiment, the slots 16, 17 are merely a section of the lamella 2 having a decreased thickness along the longitudinal axis LA of the lamella.

[0076] According to a further embodiment, it is to be understood that the lamella 2 may comprise one slot and a reduced thickness of just the one side, e.g. to create a substantially even top surface 40.

[0077] Fig. 4F shows the flexibility of the projecting legs 12, 13. Fig. 4F is highly schematic and the flexibility is typically not more than a few millimetres which is sufficient to achieve a snap-locking effect. When mounting the fixation element 5 on the mounting element 3, i.e. inserting the projecting legs into the grooves 8, the second projecting leg 13 is the one to be inserted last. Hence, the second projecting leg 13 is more likely to be deflecting than the first projecting leg 12. This is due to the fact that the projection 24 of the groove 8 (seen in Fig. 3) supports the projecting leg at a point positioned further towards the body 9 of the fixation element. When the projection 24 supporting the projecting leg 12 is positioned further towards the body 9, the force subjected to the "arm" results in a smaller bending moment of the first projection leg 12 in relation to the second projecting leg 13. Hence, the second projecting leg 13 is more likely to deflect than the first projecting leg 12 when considering the same thickness of the legs.

[0078] The first projecting leg 12 is similar to those shown in Figs. 1-3, 4, 4A, 4B and 4C.

[0079] Fig. 4G and Fig. 4H show further embodiments of the fixation element 5. In Figs. 4G

and 4H, the alignment projections 12, 13 are shorter in relation to the extension of the lamella than the alignment shown in Figs. 1-4F. The alignment projections 12, 13 still keep the lamella 2 in position along the longitudinal axis of the fixation element 5. Furthermore, the triangular cross section of the alignment projections 12, 13 provide a sloped side of each alignment projection that will assist in carrying water from the first alignment projection 14 towards the second alignment projection 15. Typically, rain will be deflected by the lamella. However, in some instances the rain may find its way to the fixation element, and in these situations the present embodiment provides an improved water drainage. It will be understood that this issue may arise during horizontal mounting of the lamellae but it will be understood that the lamella mounting system may provide for the lamellae to be mounted in a vertical manner, too. Similar to Fig. 4G the embodiment shown in Fig. 4H will provide the same drainage of water. It is shown, that the end parts 22, 23 of the projecting legs may have a more rounded outline than the end parts shown in the other embodiments of the fixation element 5. It will be understood that the end parts shown in Figs. 4G and 4H may also be similar to those of Figs. 4A-4F, also in relation to an embodiment only comprising one projecting leg and one end part (as e.g. shown in Fig. 4A).

[0080] Fig. 5 shows the mounting process when mounting a lamella 2 affixed to the fixation element 5 as seen comprising a first projecting leg 12 similar to the ones shown in Figs. 1-3, 4, 4A, 4B and 4C. Due to the first end part 22 having an increased thickness extending to both sides of projecting leg 12, the end part 22 may not be inserted directly into the groove 8 due to the projections 24. However, when the fixation element 5 and hence the first projection leg 12 is tilted more than 10° , the end part 22 is so configured as to be able to be inserted in the groove 8. Having inserted the first end part 22 in a groove, the fixation element 5 and hence the first projection leg 12 are pivoted and the first end part 22 is in a locked position and hence prevented from being drawn out of the groove again. Pivoting the fixation element 5 even further, the second projecting leg 13 contacts a groove 8, and the increased end part 23 of the second projecting leg 13 only projecting towards the first projecting leg 12 ensures that the second end part may still be inserted in a groove. The increased thickness of the second end part 23 ensures that a snap lock function is achieved and that the fixation element 5 as a whole is locked to the mounting element 3. The fixation element 5 shown in Fig. 4D may be mounted in a similar manner, but this embodiment of the fixation element 5 further provides the possibility of mounting it directly along the arrow MD shown in Fig. 4D, i.e. without pivoting around the first end part 22 of the first projecting leg 12. The metal mounting element 3 is affixed to the face 4 by a bracket. The metal mounting element 3 may also be affixed to the face 4 by a screw e.g. an expansion screw.

[0081] Hence, the end part 22 of the first projecting leg 12 of the fixation element 5 and the connecting part of the metal mounting element 3 are arranged to be lockingly engaged substantially without touching each other during mounting of the fixation element 5 when inserting the end part 22 of the first projecting leg 12 from a position in which the first projecting leg 12, and thereby the fixation element 5 as a whole, is tilted by more than 5° and less than 80° from perpendicular to the metal mounting element 3.

[0082] Figs. 6A-6D show further embodiments of the lamella 2 according to the invention. It will be understood by a person skilled in the art that the front surface of the lamella 2 may have various contours and shapes. As shown in Fig. 4A, it is furthermore shown that the top surface 40 and the front surface 41 may have a common area and as such may not be separated by a distinct edge or similar.

[0083] Fig. 6D shows a lamella 2 comprising a drip edge 61.

[0084] Figs. 7A and 7B each show an embodiment of a section of a fixation element 5, wherein the body of the fixation element comprises a number of apertures 70.

[0085] The fixation element may comprise apertures that are 2-20 mm or 3-15 mm or 4-10 mm, or more preferred 5 mm. It is seen that a number of the apertures are elongated apertures. If the lamella (not shown) to be mounted to the fixation element 5 is less likely to expand, either due to the material of the lamella or the specific conditions of the surroundings in which the lamella front surface system is mounted, the apertures 70 may be substantially round. If the lamella is likely to contract or expand in relation to the fixation element 5, the apertures may be elongated. The elongated apertures 71 have a longitudinal extension of 7.5-50 mm or 10-40 mm or 12.5-30 mm, or more preferred 15-20 mm. In the embodiment shown in Fig. 7, the apertures 70, 71 are shown in the body 9 of the fixation element 5. It will be understood by a person skilled in the art that the apertures may be arranged in either the first or second alignment projection 14, 15 or in two or more of the body 9, the first alignment projection 14 and the second alignment projection 15. Furthermore, it is understood that the screws may be inserted through the lamella and into the fixation element 5. This may be carried out using blind holes in order to hide and/or protect the screw.

[0086] In this way it is possible for the lamella 2 to expand or subtract, i.e. extend or contract differently and at least along the longitudinal axis LA from the fixation element 5 due to changes in temperature and/or humidity in the surrounding environment.

[0087] In Fig. 7B it is shown that the elongated aperture 71 and the substantially round apertures 70 are arranged within 5-50 mm of each other. In this way, it is possible, along the full length of the fixation element, to decide the direction in which the wood may extend or subtract, e.g. due to changes in humidity or temperature. Workers may, at a site of mounting the lamella, change the point of fixation in order to adjust to the specific location, e.g. near corners. In this way, the overall appearance of the system will maintain its intended finish, e.g. near corners of a room or a building.

[0088] Fig. 8A and Fig. 8B each show a fixation part (a fixation bracket) 80a and 80b. Fig. 8A shows a fixation part 80a having a substantially circular aperture 81. Opposing the side part comprising a circular aperture, the fixation part 80a comprises cut-outs 82 that delimits a part of the fixation part in order to constitute a lock part 83 in each side of the fixation element 80a. The lock parts 83 are arranged to engage with lock projections 90 of the mounting element 5 (not shown in Fig. 8A and 8B, described in Figs. 9 and 10).

[0089] Figs. 9A-9C show the mounting of the fixation element 80a. It is shown that the fixation part 80a is locked to the mounting element 3 in each side of the mounting element 3 by engaging locking projections 90 extending in a plane substantially parallel to the mounting side of the mounting element 3. Simply by rotating the fixation part 80a ninety degrees, the lock parts 83 of the fixation part 80a are lockingly arranged between the locking projections 90 and the mounting side 6. In this locked position the locking projections 90 are arranged in the cut-outs 82. In this way, the fixation part 80a is fixed in a plane perpendicular to the mounting element 3. Then, when mounting a screw or similar through the aperture 81 (only visible in Fig. 9A) and into the fixation element 5, the fixation element 5 is fully affixed to the mounting element 3.

[0090] Figs. 10A-10C show the mounting of the fixation element 80b. It is shown that the fixation part 80b is locked to the mounting element 3 in each side of the mounting element 3 by engaging locking projections 90 extending in a plane substantially parallel to the mounting side of the mounting element 3. Simply by rotating the fixation part 80b ninety degrees, the lock parts 83 of the fixation part 80b are lockingly arranged between the locking projections 90 and the mounting side 6. In this way, the fixation part 80b is fixed in a plane perpendicular to the mounting element 3. Then, when mounting a screw or similar through the elongated aperture 88 and into the fixation element 5, the fixation element 5 is affixed to the mounting element 3, but only in a direction perpendicular to the mounting side of the mounting element 3. The elongated aperture 88 allows for movement of the lamella along the longitudinal axis (LA shown in Fig. 1) in relation to the fixation element 5 due to changes in temperature.

[0091] In this way it is shown in Figs. 8A and 8B Figs. 9A-C and Figs. 10A-C that the fixation part 80a provides a 0-point for the longitudinal movement of the fixation element 5. Since most of the longitudinal movement arises from changes in temperature, this 0-point may also be called a thermal fixation point, i.e. a fixed point of the lamella 2 and fixation element 5 despite thermal changes. The fixation part 80b provides a fixation in a manner that the fixation element 5 may still be moving along the longitudinal axis LA of the fixation element 5 but in other directions fully affixed to the mounting element 3, i.e. securing the fixation element 5 in the opposite direction of the mounting direction MD shown in Fig. 4D. It will be understood that the fixation parts 80a and 80b primarily will be affixed to the side of the fixation element 5 comprising the second projecting leg 13. This is due to the substantially flat surface of the second leg 13. However, it will also be possible to mount the fixation parts to the other side, i.e. first leg 12. The effect of the fixation parts 80a and 80b are the same no matter whether they are mounted from below, e.g. if mounted to the system shown in Fig. 3 and Fig. 5 or from above as shown in Figs. 9A-C and 10A-C.

[0092] In Figs. 9A-C it is shown that the substantially circular aperture 70 is present in the fixation element. In this way the 0-point for movement of the lamella 2 in relation to the fixation element 5 is in the same position as the 0-point for the fixation element 5 in relation to the mounting element 3. Due to the fact that the lamella 2 and the fixation element expand and contract differently due to their different materials, it is possible to control the visual effect of

the different expansion and contraction. If the 0-point is placed near the end of a lamella and the fixation element 5, it is achieved that the visual effect is in fact primarily visible in the opposing end. In the same way, it is possible to fix the lamella and the fixation element at the midpoint of the fixation element and hence achieve that the total relative movement between the lamella and the fixation element is divided to take place at each end, i.e. half the total relative movement in each end. In this situation, the relative movement will typically be directed in opposite direction when comparing the one end in relation to the other end. Therefore, the total relative movement is considered in numerical (absolute) values.

[0093] Fig. 11A shows an embodiment of the fixation element 5 comprising multiple sets of first and second alignment projections 14, 15. It is seen that the two fixation elements 5 comprises alignment projections for comprising three lamellae (not shown). It is seen that the fixation elements 5 are fixated to the mounting element 3 in the same manner as if each fixation element 5 only comprised one lamella. It is shown that the fixation element 5 comprises an extended portion 110 abutting an abutting fixation element 5. The fixation element and/or the extended portion may comprise a lip made of e.g. natural rubber or similar and in this way create a substantially closed surface.

[0094] Fig. 11B shows an embodiment of the fixation element 5 comprising multiple sets of first and second alignment projections 14, 15. It is seen that the two fixation elements 5 comprise alignment projections for comprising two lamellae (not shown). It is seen that the fixation elements 5 are fixated to the mounting element 3 in the same manner as if each fixation element 5 only comprised one lamella. It is shown that the fixation element 5 comprises an extended portion 110 arranged substantially in a 90° angle to the body of the fixation element 5. In this way it is achieved that only a minor part of the mounting element 3 is visible and a closed appearance is provided.

[0095] Fig. 11C shows an embodiment of the fixation element 5 comprising multiple sets of first and second alignment projections 14, 15. It is seen that the two fixation elements 5 comprise alignment projections to comprise three lamellae (not shown). It is seen that the fixation elements 5 are fixated to the mounting element 3 in the same manner as if each fixation element 5 only comprised one lamella. It is shown that the fixation element 5 comprises an extended portion 110 abutting an abutting fixation element 5. The fixation element and/or the extended portion may comprise a lip made of e.g. natural rubber or similar and in this way create a substantially closed surface. In this embodiment, the fixation element further comprises an indentation 111 arranged to at least partly receive the extending portion 110. Similar to the embodiment shown in Fig. 11A, this embodiment closes the surface in order to create a uniform appearance and to protect the wall/surface behind the system. The extending portion 110 or the indentation 111 may comprise a lip made of rubber or similar (not shown).

[0096] Fig. 11D shows a system similar to that of Fig. 11C. In this embodiment, the indentation 111 further comprises an insert 112 made from e.g. rubber or similar flexible material. The insert 112 constitutes as a lip itself and therefore closes the gap between two abutting fixations elements 5. The insert may further comprise a projecting lip 113 and in this way achieve that

even further sealing is obtained. In this way it is achieved that the system provides an improved sealing against e.g. rain or snow. The embodiment shown in Fig. 11D is shown without a mounted wood lamella but it will be understood that these are mounted as shown in e.g. Fig. 12 using the first and second alignment projections 14, 15.

[0097] Fig. 11A-11D show that the first and second projecting legs 12, 13 are arranged similarly to fixation elements holding just one lamella. Furthermore, it is seen that the alignment projections 14, 15 may be carried out in a similar manner on all embodiments.

[0098] Fig. 12 shows the lamella system shown in Fig. 11C having the lamellae 2 mounted on the fixation elements 5. It is seen that the first and second alignment projections 14, 15 fixate the lamellae in a similar manner as to fixation elements comprising one lamella. The first and second projection legs 12, 13, are arranged similarly to fixation elements holding just one lamella.

[0099] Fig. 13 shows an embodiment of the system comprising smaller mounting elements 3. The mounting of a fixation element 5 to a face 4 of a building, e.g. a wall, ceiling or façade, is carried out by two or more individual mounting elements 3. The mounting axis MA is substantially perpendicular to the longitudinal axis of the fixation element, i.e. the lamella 2. The mounting element 3 may be individual sections of the mounting elements shown e.g. in Fig. 1, 2, 3 or 11. However, the individual nature of the mounting element facilitates a further embodiment shown in detail in Fig. 14.

[0100] Fig. 14 shows an embodiment of the mounting element 3. In this embodiment, the mounting element 3 is arranged to lockingly engage with the fixation element 5 by providing projection portions 140, 141 for lockingly engage with the embossed regions 22, 23 of the projecting legs 12, 13 of the fixation element 5. When the fixation element is forced in the mounding direction MD to engage with the mounting element 3, the projecting legs 12, 13 deflect (similar to what is shown in Fig. 4F) and lock behind the projecting portions 140, 141. It is shown that the lamella 2 is kept in position by projections 12, 13 similar to other embodiments.

[0101] Although the invention has been described in the above in connection with preferred embodiments of the invention, it will be evident for a person skilled in the art that several modifications are conceivable without departing from the invention as defined by the following claims.

REFERENCES CITED IN THE DESCRIPTION

Cited references

This list of references cited by the applicant is for the reader's convenience only. It does not form part of the European patent document. Even though great care has been taken in compiling the references, errors or omissions cannot be excluded and the EPO disclaims all liability in this regard.

Patent documents cited in the description

- WO2014068551A [0003]
- EP0685614A1 [0003]

Patentkrav

1. Lamelfrontoverfladesystem (1), der omfatter:
- mindst én lamel (2), der er fremstillet af et ikke-metalmateriale, hvor
- 5 lamellen (2) omfatter mindst én justeringsnot (16),
- mindst to metalmonteringselementer (3), der hver har en monteringsakse (MA), og som er konfigureret til at blive fastgjort til en understøtning (4), f.eks. en bygningsflade,
- idet hvert metalmonteringselement (3) omfatter:
- 10 - en monteringside (6), der ligger an mod understøtningen i dens monterede stilling,
- en grænsefladeside (7), der er anbragt modsat monteringsiden, idet grænsefladesiden omfatter et fastgørelsesmiddel (8),
- hvor lamelfrontoverfladesystemet endvidere omfatter:
- 15 - et fikseringselement (5), der er konfigureret til at blive fastgjort til de mindst to metalmonteringselementer (3), idet fikseringselementet (5) har en langsgående udbredelse (FA) og har:
- en krop (9) med en første side (10), der omfatter grænseflademidler (12, 13), som er konfigureret til at blive forbundet med fastgørelsesmidler (8),
- 20 og
- en anden side (11), der er konfigureret til at understøtte lamellen (2) i en position, som er i det væsentlige vinkelret i forhold til metalmonteringselementernes (3) monteringsakse (MA), hvor den anden side (11) omfatter mindst ét justeringsfremspring (14), som er konfigureret
- 25 til at strække sig ind i den mindst ene lamels mindst ene justeringsnot (16),
- kendetegnet ved, at** den mindst ene lamel er konfigureret til at blive fastgjort til fikseringselementet (5) ved hjælp af skruer.
2. Lamelfrontoverfladesystem (1) ifølge krav 1, hvor grænseflademidlerne på
- 30 fikseringselementets (5) første side omfatter mindst ét første udragende ben (12), der rager ud fra fikseringselementets (5) krop (9), idet det første udragende ben (12) er konfigureret til at blive forbundet med metalmonteringselementets (3) fastgørelsesmiddel (8).
- 35 3. Lamelfrontoverfladesystem (1) ifølge krav 2, hvor en endedel (22) af det mindst ene første udragende ben (12) omfatter et område med øget tykkelse.

4. Lamelfrontoverfladesystem (1) ifølge krav 1-3, hvor fastgørelsesmidlet (8) er et antal noter arrangeret på grænsefladesiden (7), idet noterne er konfigureret til at modtage mindst ét første udragende ben (12) af fikseringselementet (5).
- 5 5. Lamelfrontoverfladesystem (1) ifølge krav 3 eller 4, hvor det første udragende bens (12) endedel (22) og en not af fastgørelsesmidlet (8) udgør et kliklåsearrangement.
6. Lamelfrontoverfladesystem (1) ifølge krav 2-5, hvor den første side af fikseringselementet (5) omfatter et andet udragende ben (13), der har en endedel, 10 idet det andet udragende bens (13) endedel er i en i det væsentlige vinkelret position og konfigureret til at gå i låseindgreb med metalmonteringselementets (3) fastgørelsesmiddel (8).
- 15 7. Lamelfrontoverfladesystem (1) ifølge krav 2-6, hvor lamellens (2) langsgående udbredelse er forskellig fra fikseringselementets (5) længde.
8. Lamelfrontoverfladesystem (1) ifølge et hvilket som helst af de foregående krav, hvor lamellens (2) langsgående udstrækning er mere end 5 mm længere end 20 fikseringselementets (5) langsgående ududstrækning.
9. Lamelfrontoverfladesystem (1) ifølge krav 8, hvor lamellens (2) langsgående udstrækning er længere end fikseringselementets (5) langsgående udstrækning med 10-100 mm eller mere.
- 25 10. Lamelfrontoverfladesystem (1) ifølge et hvilket som helst af kravene 2-9, hvor, når det første udragende bens (12) endedel (22) indføres fra en position, hvor det første udragende ben (12), og dermed fikseringselementet (5) som helhed, er vippet med mere end 5° og mindre end 80° i forhold til vinkelret på 30 monteringsselementet (3), enddelen (22) af fikseringselementets (5) første udragende ben (12) kan indføres i monteringsselementets (3) fastgørelsesmiddel (8) i det væsentlige uden at røre hinanden, og når de vippes til en anden position end ca. 5°-80°, er de indrettet til at være i låseindgreb.
- 35 11. Lamelfrontoverfladesystem (1) ifølge et hvilket som helst af kravene 2-10, hvor fikseringselementet (5) omfatter mindst ét justeringsfremspring (14), der

strækker sig fra den side af kroppen (9), som er modsat den side, hvorfra det mindst ene første udragende ben (12) strækker sig.

5 12. Lamelfrontoverfladesystem (1) ifølge krav 11, hvor det første udragende ben (12) har en første udbredelse, og det andet udragende ben (13) har en anden udbredelse, hvor den første og anden udbredelse er 5-100 mm, fortrinsvis 7,5-75 mm eller især 10-50 mm.

10 13. Lamelfrontoverfladesystem (1) ifølge krav 1, hvor fikseringselementets (5) krop omfatter åbninger (70), idet åbningerne er 2-20 mm eller 3-15 mm eller 4-10 mm, eller fortrinsvis 5 mm, og hvor et antal af åbningerne er aflange åbninger (71).

15 14. Anvendelse af lamelfrontoverfladesystemet (1) ifølge krav 1-13 med henblik på i det mindste delvis at dække en konstruktion såsom en bygning eller en del af en bygning.

DRAWINGS

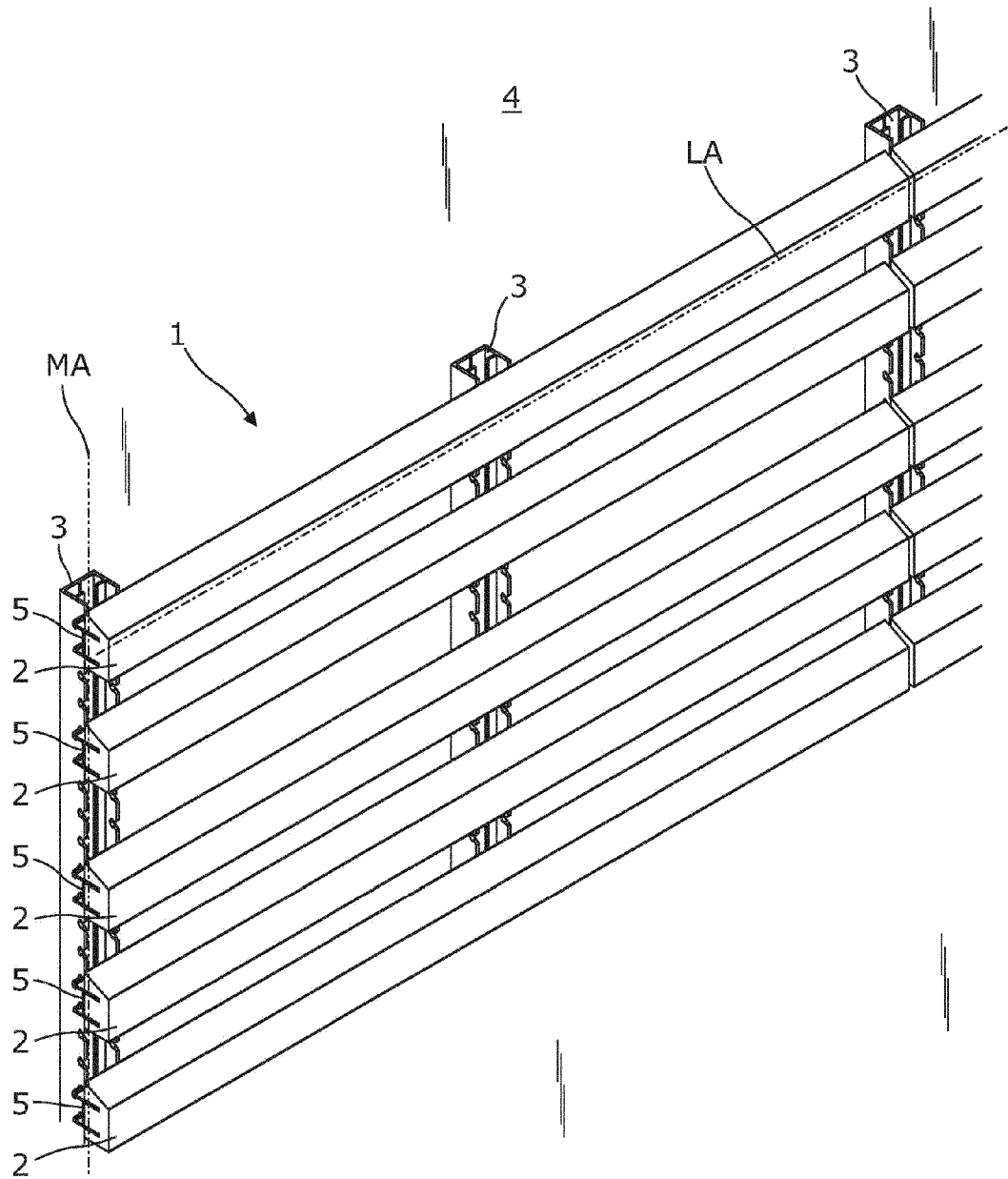

Fig. 1

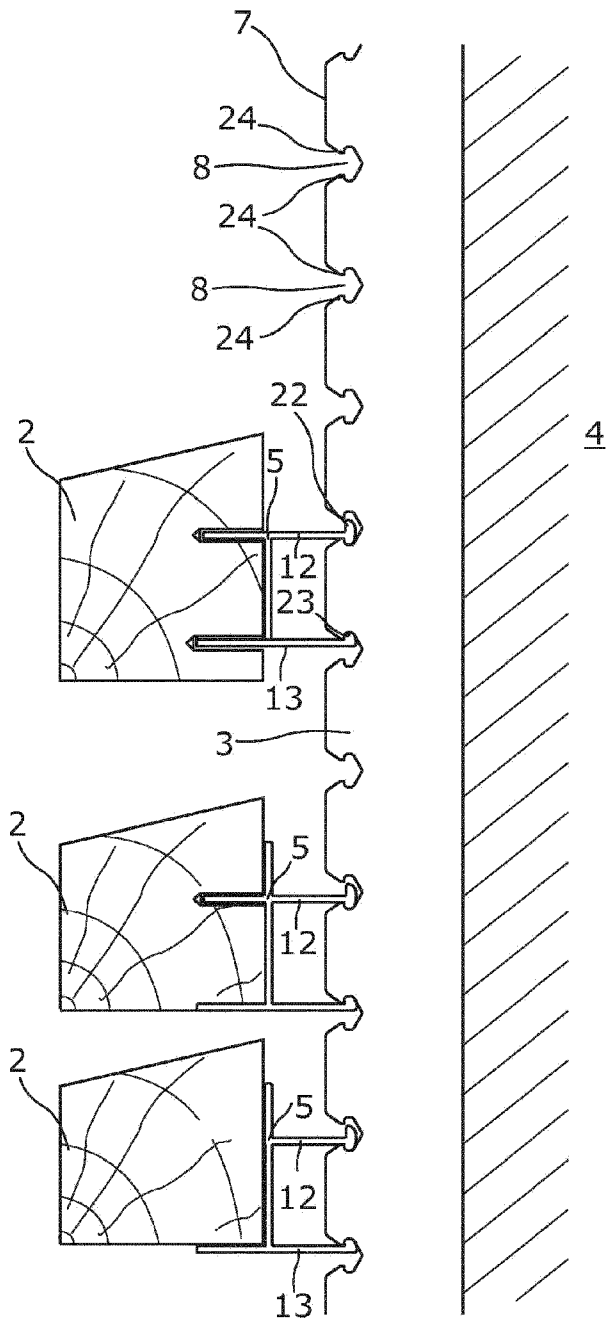

Fig. 3

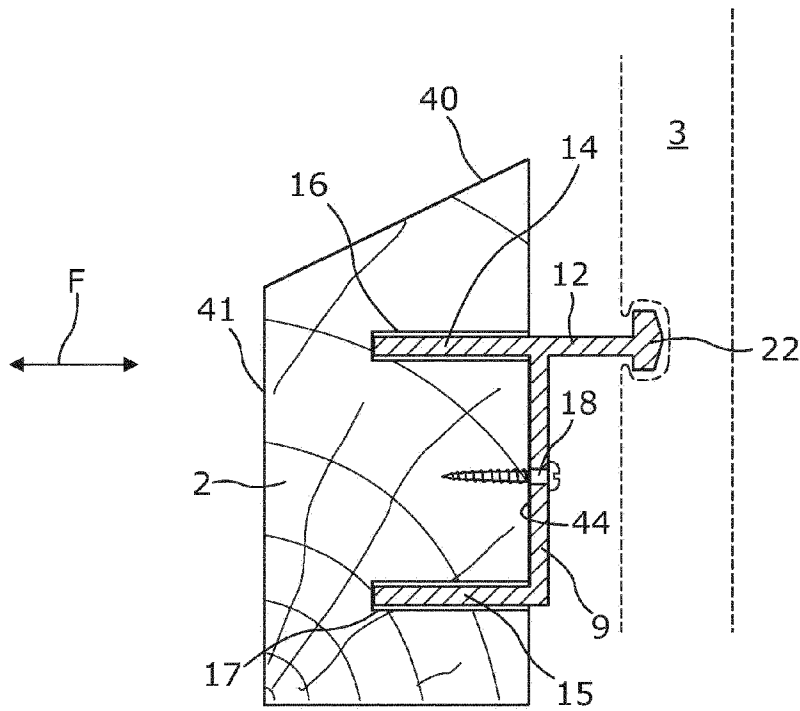

Fig. 4A

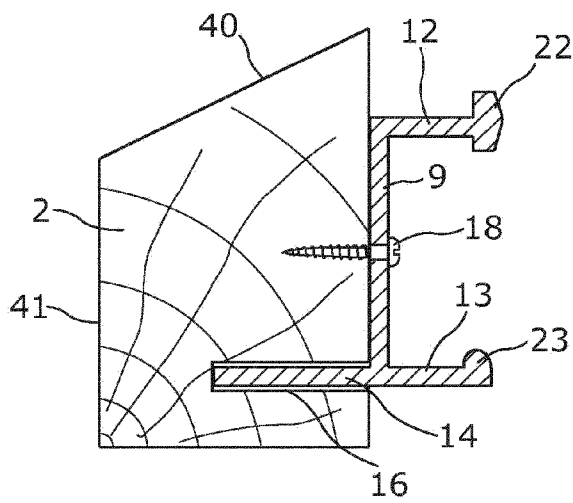

Fig. 4B

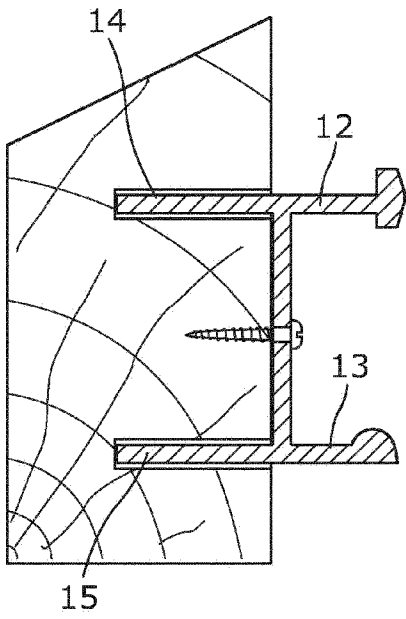

Fig. 4C

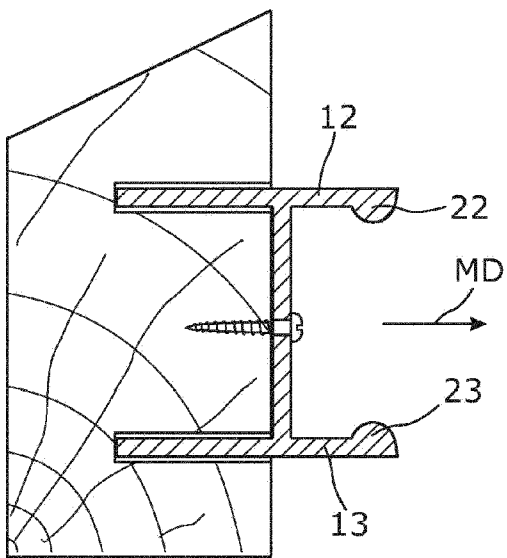

Fig. 4D

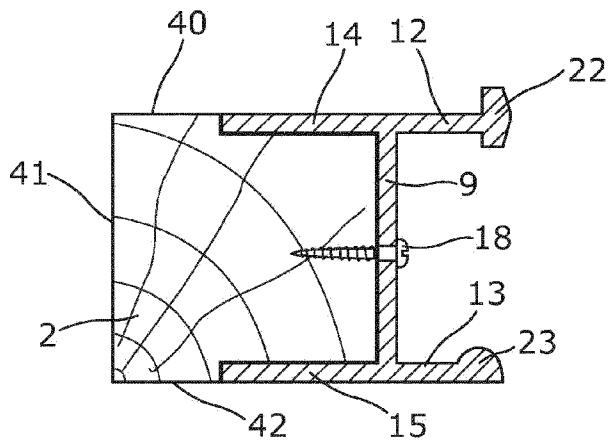

Fig. 4E

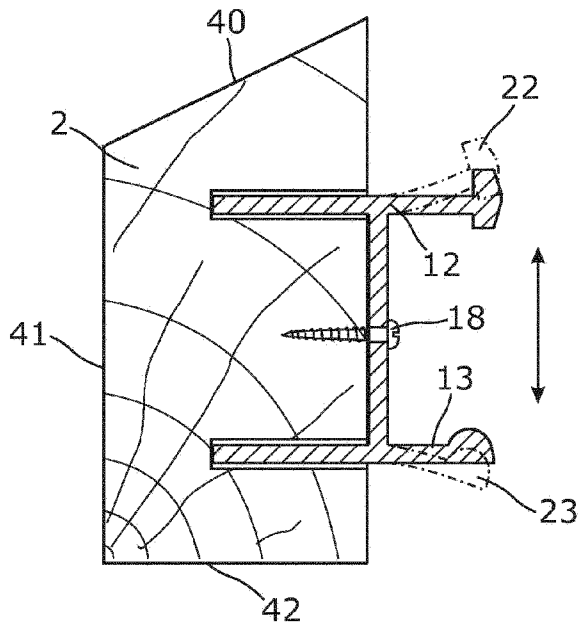

Fig. 4F

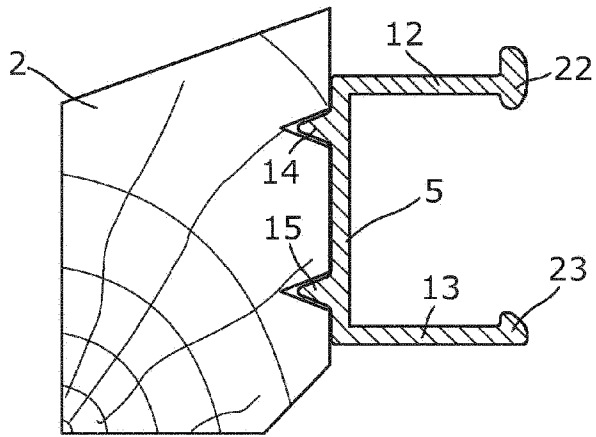

Fig. 4G

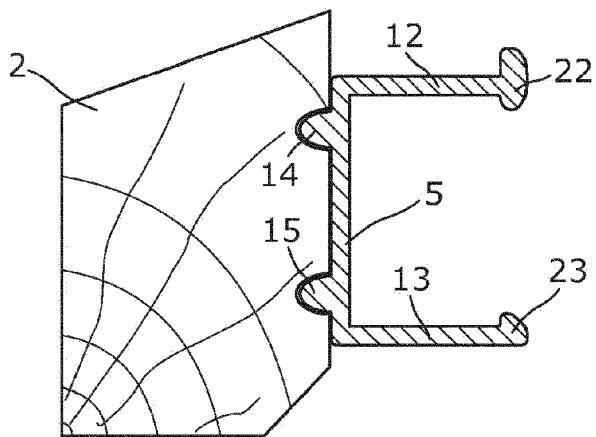

Fig. 4H

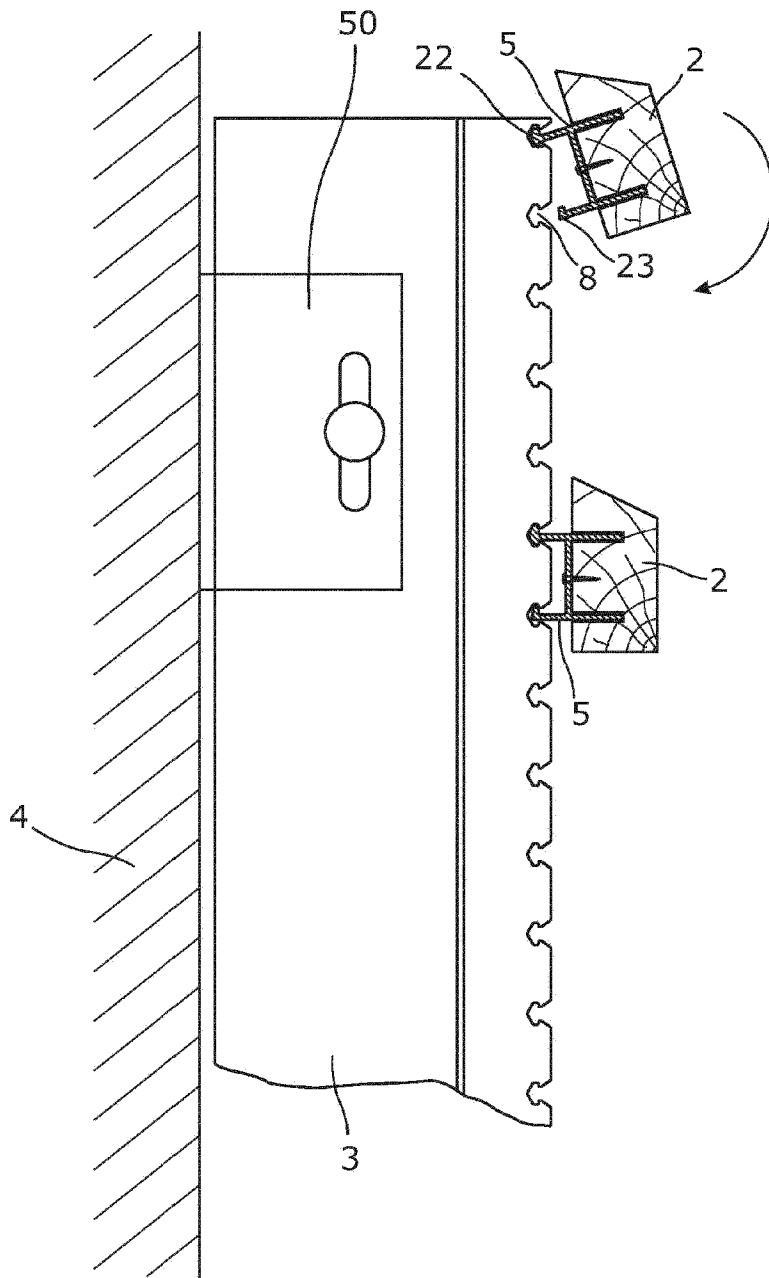

Fig. 5

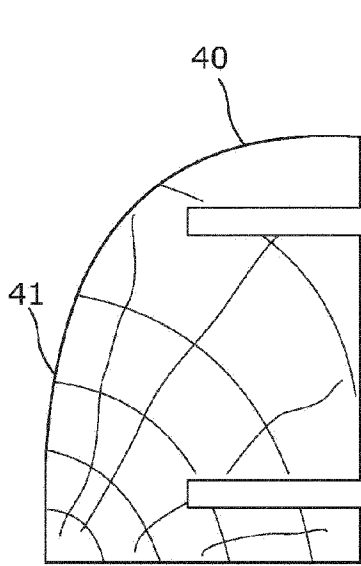

Fig. 6A

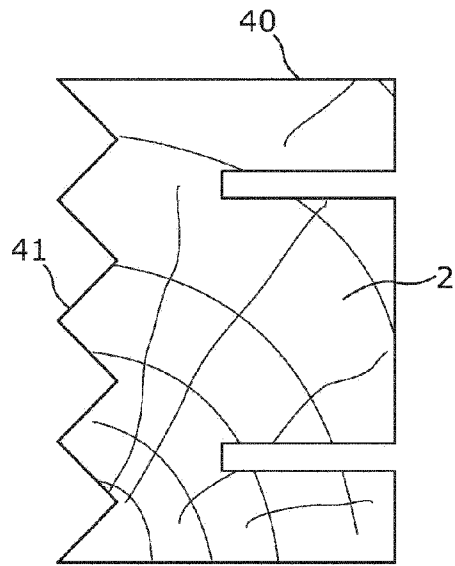

Fig. 6B

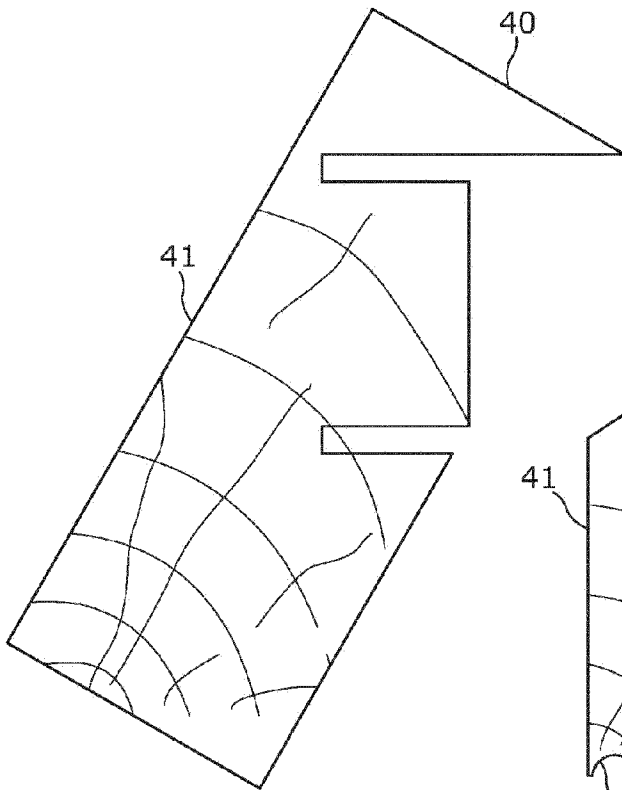

Fig. 6C

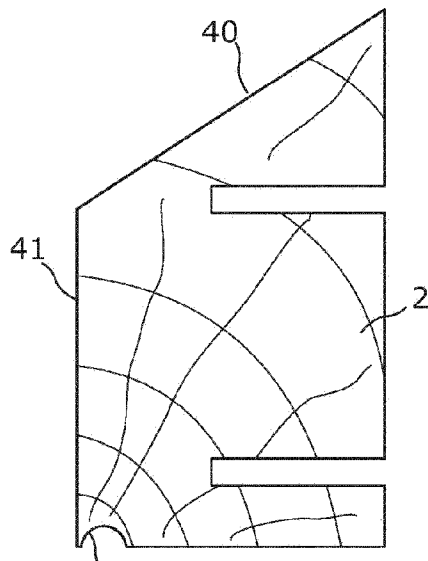
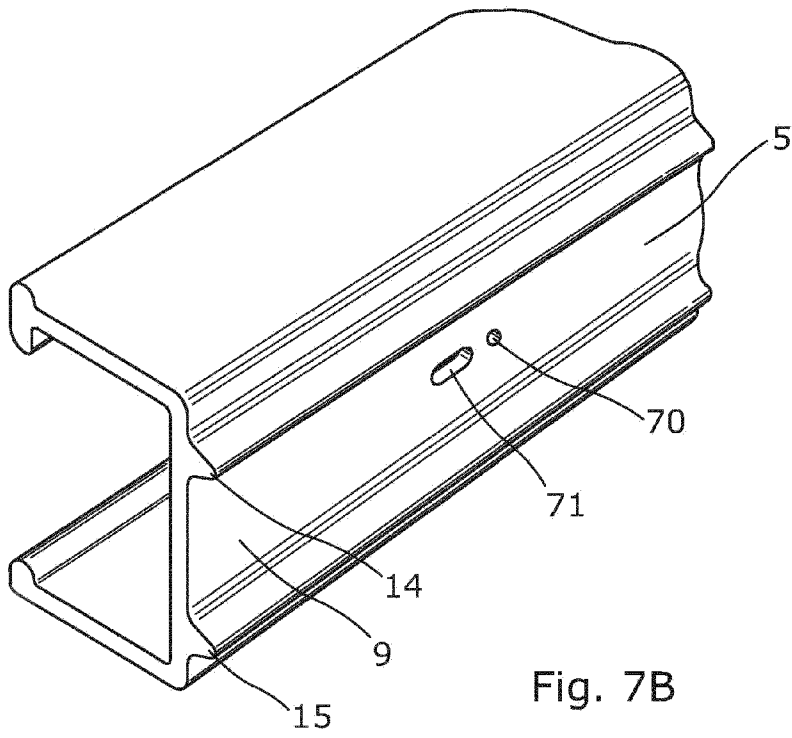
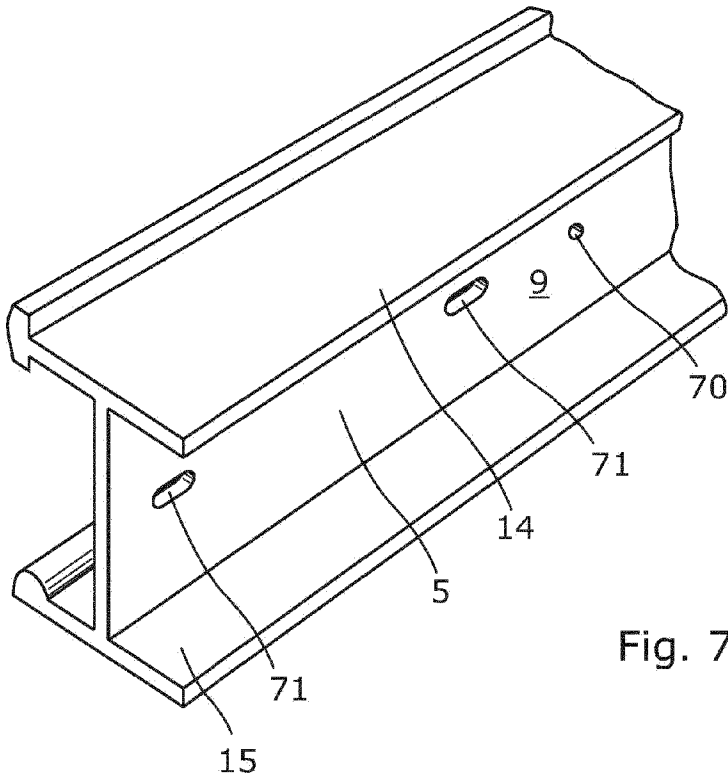

Fig. 6D



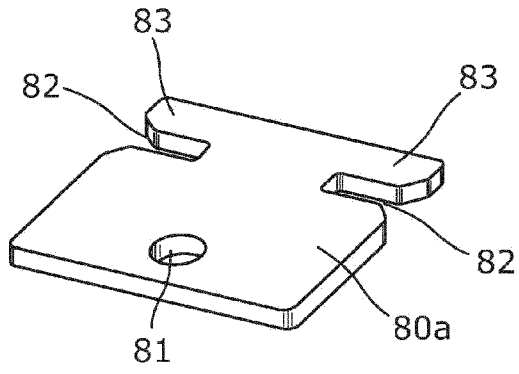

Fig. 8A

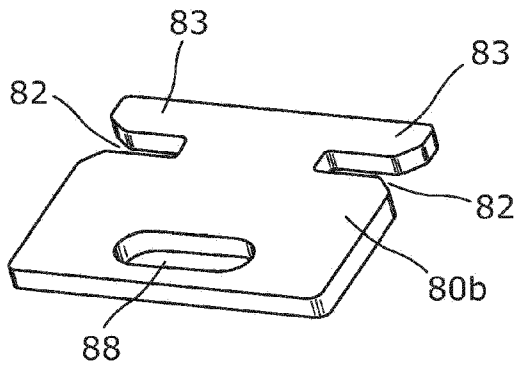

Fig. 8B

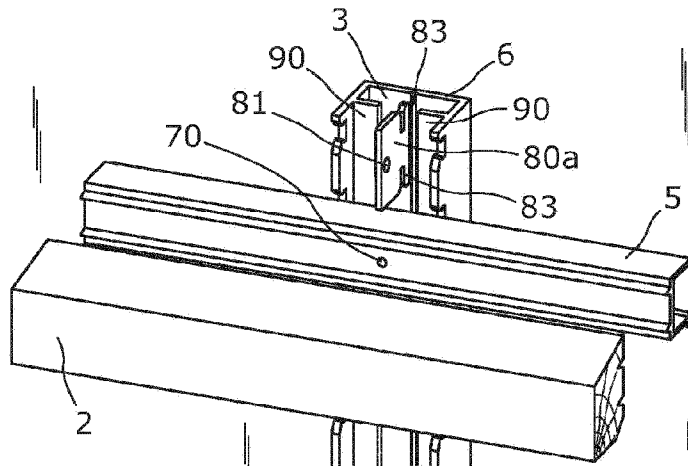

Fig. 9A

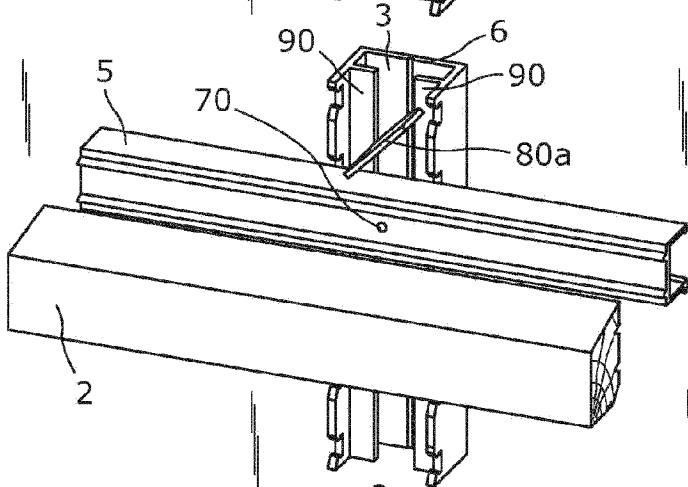

Fig. 9B

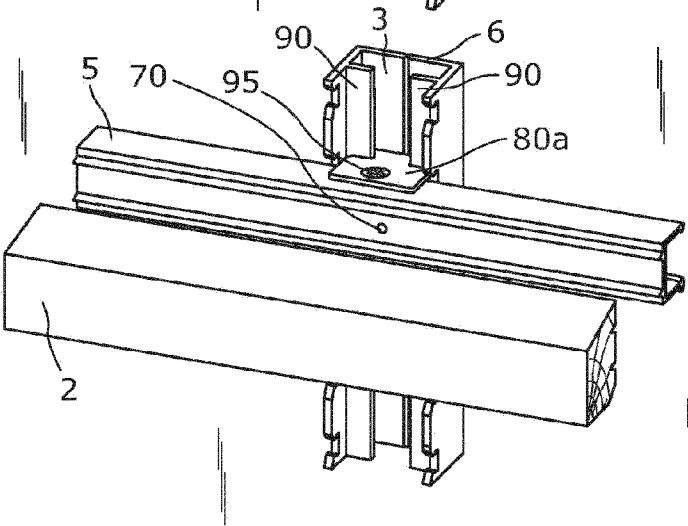

Fig. 9C

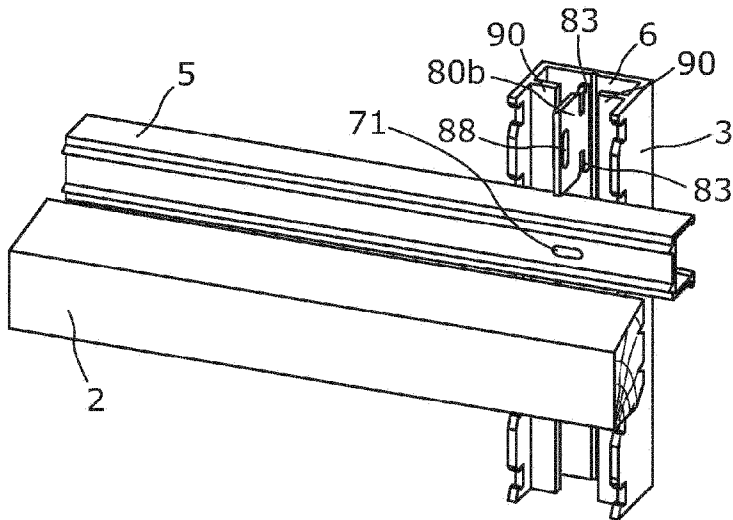

Fig. 10A

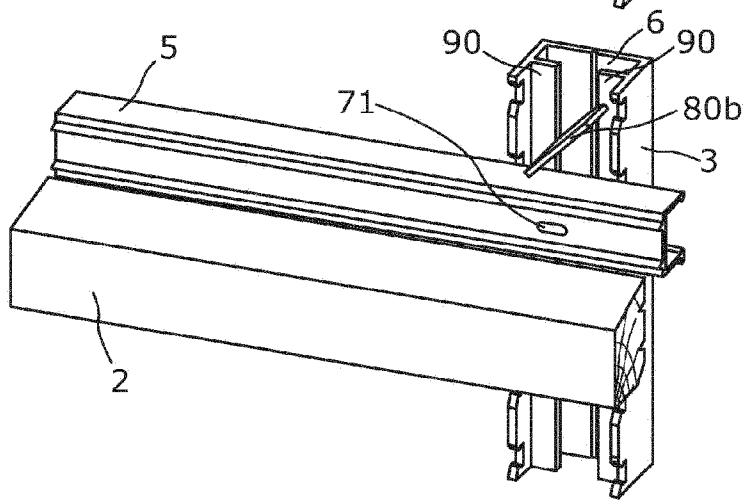

Fig. 10B

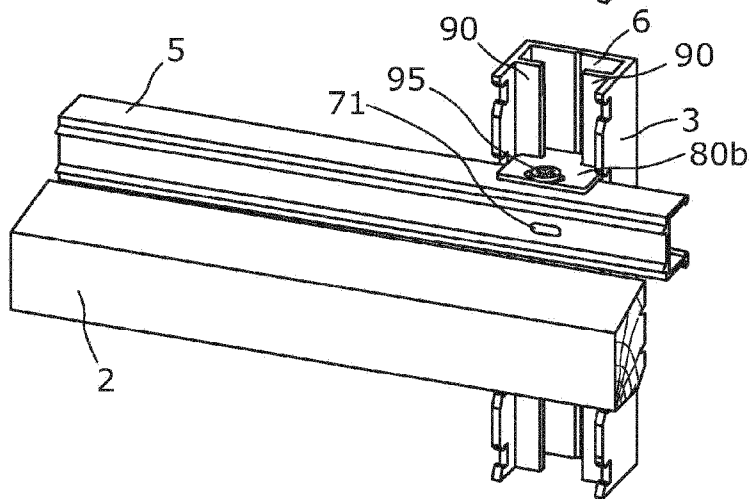

Fig. 10C

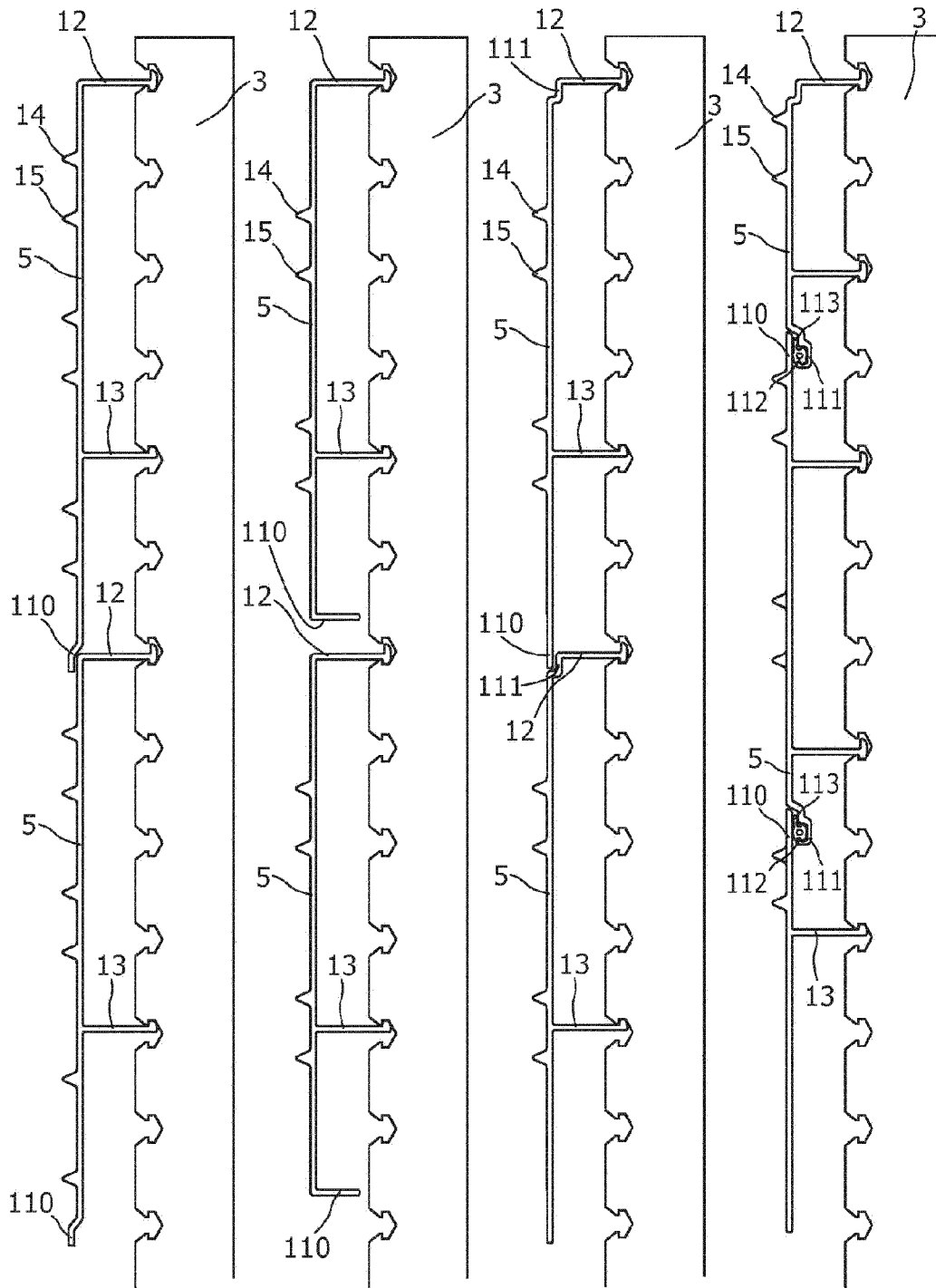

Fig. 11A

Fig. 11B

Fig. 11C

Fig. 11D

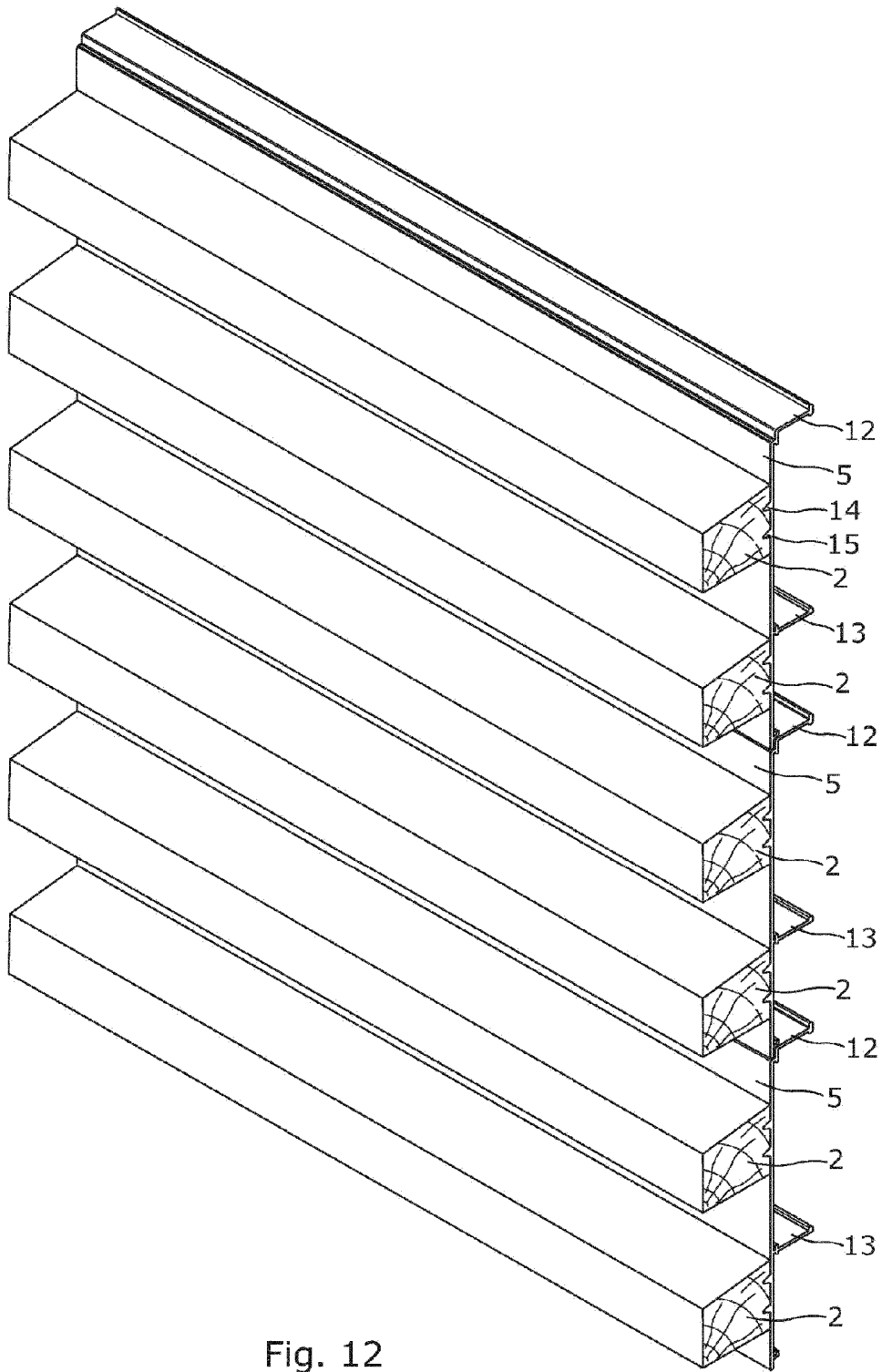

Fig. 12

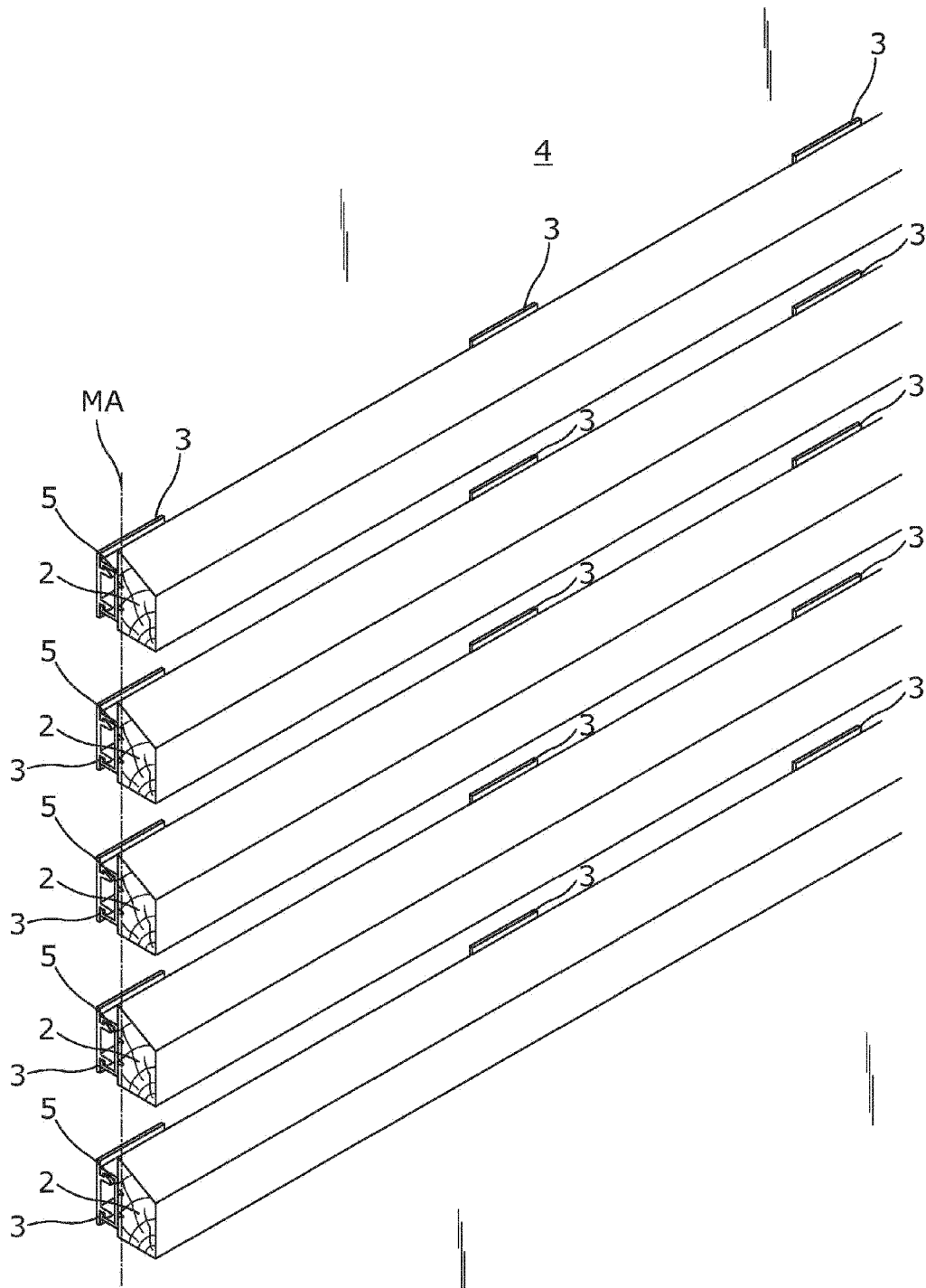

Fig. 13

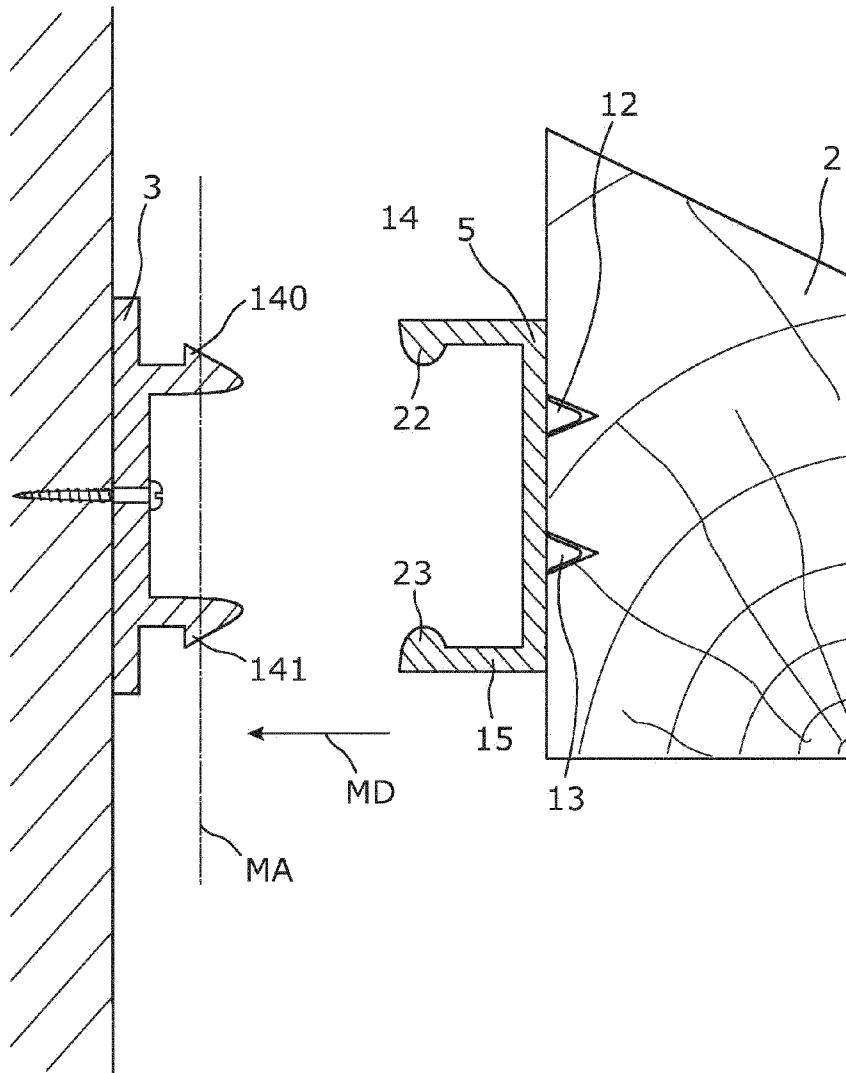

Fig. 14