

FOR THE PURPOSES OF INFORMATION ONLY

Codes used to identify States party to the PCT on the front pages of pamphlets publishing international applications under the PCT.

AL	Albania	ES	Spain	LS	Lesotho	SI	Slovenia
AM	Armenia	FI	Finland	LT	Lithuania	SK	Slovakia
AT	Austria	FR	France	LU	Luxembourg	SN	Senegal
AU	Australia	GA	Gabon	LV	Latvia	SZ	Swaziland
AZ	Azerbaijan	GB	United Kingdom	MC	Monaco	TD	Chad
BA	Bosnia and Herzegovina	GE	Georgia	MD	Republic of Moldova	TG	Togo
BB	Barbados	GH	Ghana	MG	Madagascar	TJ	Tajikistan
BE	Belgium	GN	Guinea	MK	The former Yugoslav Republic of Macedonia	TM	Turkmenistan
BF	Burkina Faso	GR	Greece			TR	Turkey
BG	Bulgaria	HU	Hungary	ML	Mali	TT	Trinidad and Tobago
BJ	Benin	IE	Ireland	MN	Mongolia	UA	Ukraine
BR	Brazil	IL	Israel	MR	Mauritania	UG	Uganda
BY	Belarus	IS	Iceland	MW	Malawi	US	United States of America
CA	Canada	IT	Italy	MX	Mexico	UZ	Uzbekistan
CF	Central African Republic	JP	Japan	NE	Niger	VN	Viet Nam
CG	Congo	KE	Kenya	NL	Netherlands	YU	Yugoslavia
CH	Switzerland	KG	Kyrgyzstan	NO	Norway	ZW	Zimbabwe
CI	Côte d'Ivoire	KP	Democratic People's Republic of Korea	NZ	New Zealand		
CM	Cameroon			PL	Poland		
CN	China	KR	Republic of Korea	PT	Portugal		
CU	Cuba	KZ	Kazakstan	RO	Romania		
CZ	Czech Republic	LC	Saint Lucia	RU	Russian Federation		
DE	Germany	LI	Liechtenstein	SD	Sudan		
DK	Denmark	LK	Sri Lanka	SE	Sweden		
EE	Estonia	LR	Liberia	SG	Singapore		

INSTRUMENT FOR MONITORING POLYMERASE CHAIN REACTION OF DNA

This invention relates to biochemical analyses, and particularly to quantitative monitoring
5 of DNA during a polymerase chain reaction (PCR) process.

BACKGROUND

Polymerase chain reaction (PCR) is a process for amplifying or multiplying quantities of
10 double-stranded deoxyribonucleic acid (DNA). In a PCR apparatus, a thermal cyclor
block has one or more wells for holding vials containing a suspension of ingredients for a
reaction to produce more DNA starting with "seed" samples of the DNA. The starting
ingredients in an aqueous suspension, in addition to the a seed sample, include selected
DNA primer strands, DNA elements, enzymes and other chemicals. The temperature of
15 the block is cycled between a lower temperature extension phase of the PCR reaction at
about 60°C, which is the phase where all of the DNA strands have recombined into double
strands, and a high temperature denaturing phase at about 95°C, during which the DNA is
denatured or split into single strands. Such a temperature program essentially doubles the
DNA in each cycle, thus providing a method for replicating significant amounts of the
20 DNA from a small starting quantity. The PCR process is taught, for example, in U.S.
patent No. 4,683,202.

Quantitative measurements have been made on the DNA production during the PCR
process, to provide measures of the starting amount and the amount produced.
25 Measurements and computation techniques are taught in U.S. patent No. 5,766,889
(Atwood), as well as in an article "Kinetic PCR Analysis: Real-time Monitoring of DNA
Amplification Reactions" by Russel Higuchi, et al., Bio/Technology vol. 11, pp. 1026-
1030 (September 1993), and an article "Product Differentiation by Analysis of DNA
Melting Curves during the Polymerase Chain Reaction" by Kirk M. Ririe, et al., Analytical
30 Biochemistry vol. 245, pp. 154-160 (1997).

Prior measuring techniques have utilized microvolume fluorometers (spectrofluorometers) and a simple arrangement of a video camera with illumination lamps. Such apparatus utilize dyes that fluoresce in the presence of double-stranded DNA. These techniques and instruments are not particularly adapted to PCR apparatus for routine monitoring of the
5 reaction. There also is a need for greater precision during the monitoring and measurements. Previous instruments that allow real time acquisition and analysis of PCR data have been very basic devices without the required dynamic range, do not have built-in calibration means, do not allow operation with sample well caps, or are very expensive.

10 An object of the present invention is to provide a novel optical instrument for quantitative monitoring of DNA replication in a PCR apparatus. Other objects are to provide such an instrument with improved dynamic range, automatic selection of exposure time to extend dynamic range, automatic adjustment for drift, simplified operation, relatively low cost, and easy changing of optics to accommodate different fluorescent dyes.

15

SUMMARY

The foregoing and other objects are achieved, at least in part, by an optical instrument as described herein for monitoring polymerase chain reaction replication of DNA. The
20 replication is in a reaction apparatus that includes a thermal cycler block for holding at least one vial containing a suspension of ingredients for the reaction. The ingredients include a fluorescent dye that fluoresces proportionately in presence of DNA.

The instrument includes a light source, means for directing light beams, a light detector,
25 and means for processing data signals. The light source emits a source beam having at least a primary excitation frequency that causes the dye to fluoresce at an emission frequency. A first means is disposed to be receptive of the source beam to effect an excitation beam having the excitation frequency. A primary focusing means is disposed to focus the excitation beam into each suspension such that the primary dye emits an
30 emission beam having the emission frequency and an intensity representative of concentration of DNA in each suspension. The focusing means is receptive of and passes

the emission beam. A second means is disposed to be receptive of the emission beam from the focusing means so as to further pass the emission beam at the emission frequency to another focusing means that focuses the emission beam onto a detector. The detector generates primary data signals representative of the emission beam and thereby a
5 corresponding concentration of DNA in each vial. A processor is receptive of the primary data signals for computing and displaying the concentration of DNA.

In a preferred embodiment, the first means and the second means together comprise a beam splitter that is receptive of the source beam to effect the excitation beam, and
10 receptive of the emission beam to pass the emission beam to the detector. The block is configured to hold a plurality of vials, and the focusing means comprises a corresponding plurality of vial lenses each disposed over a vial such that the emission beam comprises individual beams each associated with a vial. The focusing means may further comprise a
15 field lens such as a Fresnel lens disposed cooperatively with the vial lenses to effect focusing of the excitation beam into each suspension, and to pass the individual beams to the second means (beam splitter). The detector preferably comprises an array of photoreceptors receptive of the individual beams to generate corresponding data signals such that the processing means computes concentration of DNA in each vial.

20 The instrument should also include an excitation filter between the light source and the beam splitter, and an emission filter between the beam splitter and the detector. The splitter and filters are associated with a selected primary dye in the suspension. In a further embodiment, a filter module contains the splitter and filters, and the module is removable from the housing for replacement with another module associated with another
25 selected primary dye.

For a reference, a fluorescent reference member emits reference light in response to the excitation beam. The reference is disposed to be receptive of a portion of the excitation beam from the first means. A portion of the reference light is passed by the second means
30 as a reference beam to the detector, so as to generate reference signals for utilization in the computing of the concentration of DNA. Preferably the reference member comprises

a plurality of reference emitters, each emitting a reference beam of different intensity in response to the excitation beam, to allow selection by the processor of a reference set having the highest data signals that are less than a predetermined maximum that is less than the saturation limit.

5

The detector is operatively connected to the processing means for the detector to integrate emission beam input over a preselected exposure time for generating each set of data signals, and the processing means or the detector or a combination thereof have a saturation limit for the data signals. In a further aspect of the invention, the processing means comprises adjustment means for automatically effecting adjustments in exposure time to maintain the primary data within a predetermined operating range for maintaining corresponding data signals less than the saturation limit, and means for correcting the primary data in proportion to the adjustments in exposure time. Preferably, the processor computes photoreceptor data from the data signals for each photoreceptor, and the adjustment means ascertains highest photoreceptor data, determines whether the highest photoreceptor data are less than, within or higher than the predetermined operating range and, based on such determination, the exposure time is increased, retained or reduced so as to effect a subsequent exposure time for maintaining subsequent photoreceptor data within the predetermined operating range.

10
15
20

BRIEF DESCRIPTION OF THE DRAWINGS

FIG. 1 is a schematic of an optical train for an optical instrument according to the invention, associated with a polymerase chain reaction (PCR) reaction apparatus.

25

FIG. 2 is a perspective of the instrument of **FIG. 1** with a side panel removed.

FIG. 3 is an exploded perspective of a module shown in **FIG. 2**.

30

FIG. 4 is a perspective of a reference member in the optical train of **FIG. 1**.

FIG. 5 is a flow chart for computing DNA concentration from data obtained with the instrument of **FIG. 1**.

FIG. 6 is a flow chart for determining exposure time for data acquisition in operation of the instrument of **FIG. 1** and for computations in the flow chart of **FIG. 5**.

FIG. 7 is a graph of extension phase data of fluorescence vs. cycles from operation of the instrument of **FIG. 1** with a PCR apparatus.

FIG. 8 is a flow chart for computing secondary data for computations in the flow chart of **FIG. 5**.

FIG. 9 is a flow chart for computing ratios between the plurality of reference emitter segments of the reference member of **FIG. 4**.

15

DETAILED DESCRIPTION

An optical instrument **A** of the invention is utilized with or incorporated into a reaction apparatus **B** that replicates ("amplifies") selected portions of DNA by polymerase chain reaction ("PCR"). The reaction apparatus is conventional and should function without interference from the instrument which monitors the amount of DNA in real time during replication. Suitable reaction apparatus are described in U.S. patent Nos. 5,475,610 and 5,656,493.

The reaction apparatus (**FIG. 1**) is conventional and has two main components, namely a thermal cycler block **1** with wells **1a** for holding at least one vial **1b** containing a suspension of ingredients for the reaction, and a thermal cycle controller **1c** for cycling the temperature of the block through a specified temperature program. The starting ingredients of the aqueous suspension of sample materials include a "seed" sample of DNA, selected DNA primer strands, DNA elements, enzymes and other chemicals. The block, typically aluminum, is heated and cooled in a prescribed cycle by electrical means,

30

liquid or air coolant, or a combination of these, or other means to achieve the cycling. The suspensions in the vials are thereby cycled between two temperature phases so as to effect the polymerase chain reaction. These phases are a lower temperature extension phase of the PCR reaction at about 60°C, which is the phase where all of the DNA strands
5 have recombined into double strands, and a high temperature denaturing phase at about 95°C, during which the DNA is denatured or split into single strands.

For the present purpose the sample also contains a fluorescent dye that fluoresces proportionately and more strongly in the presence of double stranded DNA to which the
10 dye binds, for example SYBR Green dye (available from Molecular Probes, Inc., Eugene, Oregon) that fluoresces in the presence of double stranded DNA. Another type of fluorescent dye labeled "probes", which are DNA-like structures with complimentary sequences to selected DNA strand portions, may also be used. Other dyes that have similar characteristics may be utilized. As used herein and in the claims, the term "marker
15 dye" refers to the type that binds to double stranded DNA, or to the probe type, or to any other type of dye that attaches to DNA so as to fluoresce in proportion to the quantity of DNA. Samples may also contain an additional, passive dye (independent of the DNA) to serve as a reference as described below. Under incidence of light having a correct excitation frequency, generally a dye fluoresces to emit light at an emission frequency that
20 is lower than that of the excitation light.

The vials typically are formed conically in a plastic unitary tray containing a plurality of vials, for example 96 in an array of 12 by 8. The tray preferably is removable from the block for preparations. A plastic unitary cover with caps 1d for the vials may rest or
25 attach over the vials to prevent contamination and evaporation loss. Other means may be used for this function, such as oil on the sample surface, in which case caps are not needed. If used, the caps are transparent to light utilized in the instrument, and may be convex facing upwardly.

30 The monitoring instrument is mounted over the block containing the vials. The instrument is removable or swings away for access to the vials. In the bottom of the instrument, a

platen 2 rests over the vial caps or, if none, directly over the vials. The platen, advantageously aluminum, has an array of holes 2a therethrough aligned with the vials, each hole having a diameter about the same as the vial top diameter. If there are caps, the platen should have its temperature maintained by a film heater or other means for heating the platen sufficiently to prevent condensation under the caps without interfering with DNA replication in the vials, for example holding the platen at slightly higher temperature than the highest sample temperature that the thermal cyclers reaches.

Above each of the vials is a lens 2b positioned for its focal point to be approximately centered in the suspension in the vial. Above these lenses is a field lens 3 to provide a telecentric optical system. Advantageously the field lens is an aspherically corrected Fresnel lens for minimal distortion. A neutral density pattern (not shown) to correct nonuniformities in illumination and imaging may be mounted on or in proximity to the field lens, for example to attenuate light in the center of the image field. A folding optical mirror is optionally mounted at 45° for convenient packaging. This may be omitted, or other such folding optics may be used. Also the field lens, and/or the vial lenses, each may be comprised of two or more lenses that effect the required focusing, the word "lens" herein including such multiplicities.

A light source 11 for a source beam 20 of light is provided, for example a 100 watt halogen lamp. Preferably this is mounted at a focal distance of an ellipsoid reflector 11a which produces a relatively uniform pattern over the desired area. Also, advantageously, the reflector should be dichroic, i.e. substantially reflecting visible light and transmitting infrared light, to restrict infrared from the other optical components and from overheating the instrument. This is further aided by a heat reflecting mirror 13 in the optical path. A mechanical or electronic shutter 12 allows blockage of the light source for obtaining dark data. The type of light source is not critical, and other types may be used such as a projection lamp or a laser, with appropriate optical elements.

A beam splitter 6 is disposed to receive the source beam 20. In the present embodiment this is a dichroic reflector such that, positioned at 45°, it reflects light having an excitation

frequency that causes the marker dye to fluoresce at an emission frequency, and passes light having the emission frequency. Such a conventional optical device typically utilizes optical interference layers to provide the specific frequency response.

5 The beam splitter is positioned to reflect the source beam to the folding mirror. The source beam is reflected from the splitter as a excitation beam 22 having substantially the excitation frequency. The excitation beam is focused by the field lens 3 and then as separated beams 24 by the vial (well) lenses 2b into the center of the vials. The marker dye is thereby caused to emit light at the emission frequency. This light is passed
10 upwardly as an emission beam in the form of individual beams 26 that are reflected from the folding mirror 5 to the beam splitter 6 which passes the emission beam through to a detector 10.

Together the vial lenses 2b and the field lens 3 constitute a primary focusing means for
15 focusing both the excitation beam and the emission beam. In an alternative aspect, the field lens may be omitted so that the focusing means consists only of the vial lenses 2b. Alternatively, the vial lenses may be omitted so that the focusing means consists only of an objective lens in the field lens position to focus the individual emission beams on the detector.

20 Also, alternatively, the beam splitter 6 may pass the source beam as an excitation beam and reflect the emission beam, with appropriate rearrangement of the lamp and the detector. Moreover, other angles than 45° could be used if more suitable for the beam splitter, such as a more perpendicular reflection and pass through. More broadly, the
25 beam splitter splits the optical paths for the excitation beam and the emission beam, and other variations that achieve this may be suitable. It is desirable to minimize source light reaching the detector, which the dichroic device helps achieve. A non-dichroic beam splitter may be used but would be less efficient as significant source light may reach the detector, or may be reflected or transmitted in the wrong direction and lost.

30

To further filter the source light, an excitation filter 7 is disposed between the light source 11 and the beam splitter 6. This passes light having the excitation frequency and substantially blocks light having the emission frequency. Similarly, an emission filter 8 is disposed between the beam splitter and the detector, in this case between the splitter and a detector lens 9 in front of the detector. This filter passes light having the emission frequency and substantially blocks light having the excitation frequency. Although a detector lens is preferred, a focusing reflector may be substituted for the detector lens. Such an emission focusing means (detector lens or reflector) may be located after (as shown) or before the beam splitter and on either side of the emission filter, and alternatively may be integrated into the primary focusing means. For example, the field lens may be an objective lens that focuses the emission beam onto the detector.

Suitable filters are conventional optical bandpass filters utilizing optical interference films, each having a bandpass at a frequency optimum either for excitation of the fluorescent dye or its emission. Each filter should have very high attenuation for the other (non-bandpass) frequency, in order to prevent "ghost" images from reflected and stray light. For SYBR Green dye, for example, the excitation filter bandpass should center around 485 nm wavelength, and the emission filter bandpass should center around 555 nm. The beam splitter should transition from reflection to transmission between these two, e.g. about 510 nm, so that light less than this wavelength is reflected and higher wavelength light is passed through.

More broadly, the excitation filter and the beam splitter together constitute a first means disposed to be receptive of the source beam to effect an excitation beam having the excitation frequency, and the emission filter and the beam splitter together constitute a second means disposed to be receptive of the emission beam from the focusing means so as to pass the emission beam at the emission frequency to the detector. Also, as mentioned above, the beam splitter alternatively may pass the source beam as an excitation beam and reflect the emission beam to the detector. In another aspect, the filters may be omitted, and the first means is represented by the beam splitter effecting the excitation

beam from the source beam, and the second means is represented by the beam splitter passing the emission beam to the detector.

In another arrangement, the beam splitter may be omitted, and the first means may
5 constitute an excitation filter for the excitation frequency, the second means may
constitute an emission filter for the emission frequency, with the light source and the
detector being side by side so that the excitation and emission beams are on slightly
different optical paths angularly. The source and detector need not actually be side by side
with one or more folding mirrors. Thus any such arrangement for achieving the effects
10 described herein should be deemed equivalent. However, use of the beam splitter is
preferred so that the excitation and emission beams through the field lens will have the
same optical path.

Advantageously the beam splitter 6, the excitation filter 7 and the emission filter 8 are
15 affixed in a module 30 (FIG. 2) that is associated with a selected primary dye for the
suspension. The module is removable from the housing 32 of the instrument A for
replacement with another module containing different beam splitter and filters associated
with another selected primary dye. The instrument includes a lamp subhousing 33 and a
camera subhousing 35.

20 In an example (FIG. 3), each module includes a mounting block 34 with a flange 36 that is
affixable to the housing with a single screw 38. The beam splitter 6 is held at 45° in the
block with a frame 40 and screws 42. The emission filter 8 mounts (e.g. with glue) into
the block. The excitation filter 7 mounts similarly into a mounting member 44 that is held
25 by screws 46 to the block. With the module in place, the instrument is closed up with a
side plate 47 that is screwed on. Positioning pins (not shown) ensure repeatable
alignment. The replacement module may have the same mounting block and associated
components, with the beam splitter and filters replaced.

The detector lens 9 (FIG. 1) is cooperative with the vial lenses 2b and the field lens 3 to focus the individual beams on the detector 10. The lens should be large aperture, low distortion and minimum vignetting.

5 The detector preferably is an array detector, for example a charge injection device (CID) or, preferably, a charge coupled device (CCD). A conventional video camera containing a CCD detector, the detector lens and associated electronics for the detector should be suitable, such as an Electrim model 1000L which has 751 active pixels horizontal and 242 (non-interlaced) active pixels vertical. This camera includes a circuit board that directly
10 interfaces to a computer ISA bus. No framegrabber circuitry is required with this camera. Essentially any other digital imaging device or subsystem may be used or adapted that is capable of taking still or freeze-frame images for post processing in a computer.

A detector with a multiplicity of photoreceptors (pixels) 78 is preferable if there are a
15 plurality of vials, to provide separate monitoring of each. Alternatively a scanning device may be used with a single photodetector, for example by scanning the folding mirror and using a small aperture to the detector. Also, a simple device such as a photomultiplier may be used if there is only one vial. A CCD receives light for a selected integration period and, after analog/digital conversion, reads out digital signal data at a level accumulated in
20 this period. The integration is effectively controlled by an electronic shutter, and a frame transfer circuit is desirable. Signal data are generated for each pixel, including those receiving the individual beams of emitted light from the vials.

The instrument preferably includes a fluorescent reference member 4 that emits reference
25 light in response to the excitation beam. Advantageously the reference member is formed of a plurality of reference emitters, e.g. 6, each emitting a reference beam of different intensity in response to the excitation beam. The range of these intensities should approximate the range of intensities expected from the marker dye in the vials; for example each segment may be separated in brightness by about a factor of 2.5. The
30 reference member is disposed to receive a portion of the excitation beam from the beam splitter. A good location is adjacent to the field lens, so that the optical paths associated

with the member approximate those of the vials. Most of the reference light passes back through the beam splitter as a reference beam to the detector. The detector pixels receive the emission beam to generate reference signals for utilization along with the data signals in the computing of the concentration of DNA.

5

Advantageously the reference member 4 (FIG. 4) comprises a plastic fluorescent strip 4a and a neutral density filter 4b mounted over the fluorescent strip, optionally with an air space 4h between, such that a portion of the excitation beam and the reference beam are attenuated by the neutral density filter. The neutral density filter has a series of densities 4c to effect the plurality of reference emitters (segments) each emitting a reference beam of different intensity. A heating strip 4d and an aluminum strip 4g to smooth the heating are mounted in a trough 4e on the bottom thereof, and the fluorescent strip is mounted on the aluminum strip over the heating strip. To prevent heat loss, this assembly preferably is covered by a transparent plexiglass window (not shown, so as to display the varying density filter). To help maintain constant fluorescence, the heating strip is controlled to maintain the fluorescent strip at a constant temperature against the thermal cycles of the cyclor block and other effects. This is done because most fluorescent materials change in fluorescence inversely with temperature.

20 The computer processor 14 (FIG. 1) may be a conventional PC. The computer programming is conventional such as with "C". Adaptations of the programming for the present invention will be readily recognized and achieved by those skilled in the art. The processor selectively processes signals from pixels receiving light from the vials and the reference emitters, ignoring surrounding light. The programming therefore

25 advantageously includes masking to define the pixel regions of interest (ROI), e.g. as disclosed in copending provisional patent application serial No. 60/092,785 filed 07/14/98 of the present assignee. Mechanical alignment of the optics may be necessary to cooperatively focus the beams into the programmed regions of interest. The analog data signals are fed to the processor through an analog/digital (A/D) device 15 which, for the

30 present purpose, is considered to be part of the processor. A saturation level is proscribed by either the detector or the A/D or, preferably, the CCD dynamic range is matched to the

A/D dynamic range. A suitable range is 8 bits of precision (256 levels), and the CCD amplifier offset is set so that the dark signal output of the CCD (with the shutter 12 closed) is within the A/D range. The processor instructs the detector with selected exposure time to maintain the output within the dynamic range.

5

In a typical operation, fluorescence data are taken from the plurality of vials (e.g. 96 regions of interest) and from the reference emitter segments, for each cycle in a DNA reaction replication sequence of thermal cycles, typically 40 to 50. Two data sets are taken (FIG. 5) for each thermal cycle during the extension phase of the PCR reaction at
10 about 60°C, which is the phase where all of the DNA strands have recombined into double strands. One set is normal primary data 50 (along with reference data described below) and the other is dark signal data 51 with the mechanical shutter closed. Both digital data sets 50, 51 are converted by the A/D 15 from respective analog data signals 48, 49 from the detector. The dark are subtracted 55 from the normal, to yield dark-corrected data 57.

15 In a simple procedure, the subtraction is pixel by pixel. Alternatively, total dark for each region of interest are subtracted from corresponding total fluorescence data. In another alternative, in order to increase effective dynamic range, it is advantageous to collect multiple exposures during each exposure period, e.g. 4 or 8 exposures. This is done by collecting multiple normal exposures and dark signal data for each pixel, subtracting each
20 respective dark image from the normal data, then adding the subtracted data together to yield the primary data. This improves the statistical validity of the image data and increases its effective dynamic range.

Data are taken simultaneously from the reference strip which has, for example, 6 segments
25 together with the 96 vials for a total of 102 regions of interest. Preferably the processing means provides for automatic adjustment of the exposure time to maintain the data signals within a predetermined operating range that is less than the saturation limit during the DNA replication sequence, for example 35% to 70% of saturation. Computations for DNA concentration include corrections in proportion to adjustments in exposure time
30 (FIG. 6). Signal data 50, 51 from each exposure 52, 53 are obtained during a previously

determined exposure time 54 by totaling the pixel counts within each region of interest (ROI).

To provide the time adjustments, the highest signal data 56, which is data from one or more highest pixel readings, such as the three highest-reading contiguous pixels, is searched out 58 from the corresponding data signals 50. From a comparison 62 it is determined whether the highest signal data are less than, within or higher than the selected operating range 60. Based on such determination, the exposure time is adjusted 64, i.e. increased, retained or reduced, to obtain the subsequent exposure time 66. A reference time 68 (FIG. 5) also is selected which may be, for example, an initial time or a fixed standard time such as 1024 ms. The dark-corrected data 57 is time-corrected 69 to yield corrected primary data 71, dividing by ratio of actual exposure time to the reference time. The first several cycles may be out of range, and thereafter a useful fluorescence curve should be obtained (FIG. 7).

For the reference emitter, from the pixels receiving light from the reference strip 4 (FIGS. 1 and 4) reference data signals 73 are generated and converted by the A/D 15 to reference data 72. Selected reference data 74 from a specific reference segment 4c (FIG. 4) are selected 76 as that data having the highest signal strength that is less than a predetermined maximum 77 that, in turn, is less than the saturation limit, e.g. 70%. A next dimmer segment is also selected 75, and the selected reference data 74 include the data from that segment. The dark data 51 are subtracted 78 from the reference data 74, and the dark-corrected data 80 are adjusted 84 for exposure time 54 to yield adjusted reference data 82.

The data 82 includes dark corrected data 82' for the highest segment and dark corrected data 82'' for the next dimmer segment (FIG. 9). The ratios of brightness between each segment are computed 89 and built up over the course of data collection. Each time data is collected, the ratio between the highest and next dimmer segment is calculated. As different optimum segments are selected on succeeding data collections, a table of ratios 85 is assembled. Alternatively, these ratios may be collected and calculated in advance.

This adjusted reference data 82' (from data 82, FIG. 5) are utilized for computing normalized reference data 88 which are normalized 86 in real time as a ratio to reference data 90 from an initial or other selected previous cycle in the DNA replication (PCR) sequence by working back with the ratios 85. The normalized reference data are utilized
5 on the corrected primary data 71 in a normalization computation 92 to provide drift normalized primary data 94 by dividing the primary data by the normalized reference data. This corrects for instrument drift during the monitoring. DNA concentration 96 may then be computed 98 from a stored calibration factors 99, determined by running standard known DNA concentrations to determine the slope and intercept of a line relating starting
10 concentration to the starting cycle of the growth curve (FIG. 7) as taught in the aforementioned article by Higuchi and U.S. Patent No. 5,766,889. (Further normalization 118, 120 and baseline correction 122-130 are discussed below.)

Extension phase data for a typical PCR sequence would look like FIG. 7, plotted for each
15 PCR cycle. If desired, the data may be corrected for dye bleaching or other sample chemical effects by normalizing to sample vials containing samples with the same dye and with DNA amplification prevented chemically.

The sample additionally may contain one or more types of dye molecules that serve as a
20 "passive" reference having some fluorescence in the same wavelength range as the DNA binding dye. This reference dye is made up, for example, of a nucleic acid sequence labeled with Rhodamine and Fluorescein dye derivatives. A suitable reference is Rox dye from Perkin-Elmer Applied Biosystems. These passive dye molecules do not take part in the PCR reaction, so that their fluorescence is substantially without influence from DNA
25 and remains constant during the reaction. This fluorescence can be used to normalize the fluorescence from the DNA binding dye with a standard concentration of passive dye included in the ingredients of at least one vial, preferably in every vial.

The source beam includes a secondary excitation frequency that causes the passive dye to
30 fluoresce at a secondary frequency and thereby emit a secondary beam directed to the detector to generate corresponding secondary data signals. The processor is receptive of

the secondary data signals for computing secondary data representative of standard concentration. These data are used to normalize the primary data, so that the concentration of DNA is normalized to the standard concentration of passive dye after correcting computations of concentration of DNA in proportion to adjustments in exposure time, and in conjunction with the normalization for drift. Advantageously, and in the present example, the secondary excitation frequency is identical to the primary excitation frequency, and the passive dye fluoresces such that the emitted secondary beam is substantially at the emission frequency. The primary data signals are generated during each extension phase of cycling of the thermal cycler block when DNA is recombined and correspondingly primary dye emission is maximized. The secondary data signals are generated during each denature phase of cycling of the thermal cycler block when DNA is denatured and correspondingly primary dye emission is minimized. Thus data signals for the primary phase are substantially representative of DNA concentration, and data signals for the secondary phase are substantially representative of the standard concentration of passive dye.

The dark and normal data are taken for the vial samples and the reference strip, and the dark is subtracted from the normal fluorescence data. This dark and normal data set is taken during the extension phase of the PCR reaction at about 60°C, which is the phase where all of the DNA strands have recombined into double strands. During this phase, the fluorescence from the DNA binding dye is maximized, and the fluorescence from the passive reference molecules is superimposed but much smaller. A separate dark and normal data set is taken during the high temperature (about 95°C) denaturing phase, during which the DNA is denatured or split into single strands. During this phase, the fluorescence of the DNA binding dye is minimized, and almost non-existent, because the DNA is not double stranded and the fluorescence of the dyes used have a large decrease in fluorescence with increased temperature. Therefore the denaturing phase images substantially contain reference fluorescence from the passive reference molecules. The dark-corrected reference (denaturing) data set, after correction for measured temperature dependence, may be subtracted from the dark-corrected DNA binding dye data set, or may be deemed insignificant for the normal data set.

Alternatively, it may be desirable to image the passive reference dye labeled molecules by taking the additional images, for each PCR cycle, using a separate optical bandpass filter that rejects wavelengths emitted by the DNA binding dye while accepting wavelengths from the passive reference dye. This data would be functionally equivalent to the denature data.

Illustrating operation for the denature phase (FIG. 8), respective normal and dark data signals 102, 104 are obtained in the same manner as for the primary data, with normal exposure 52' and closed shutter 53'. Exposure time 106 may be the same as for an adjacent extension phase in the sequence, or determined from a previous denature phase run (as described with respect to FIG. 7), or may be a suitable time predetermined for all denature phases in the sequence. The A/D 15 converts the signals to secondary data 108 and dark data 110. The dark is subtracted 55' from the secondary to yield dark-corrected data 112 which is further corrected 69' with a reference time 114 and the actual exposure time 106 to yield corrected secondary data 116.

The extension cycle, drift normalized primary data 94 then are normalized 118 by dividing by the average of a selected number (e.g. 10) of cycles for the denature phase corrected secondary data 116 to produce further normalized fluorescence data or further normalized data 120, which removes sample well to well non-uniformity effects. Cycle by cycle division may be used in place of an average. Alternatively the secondary data may be applied to the corrected primary data 71 before or after drift normalization. Baseline samples may be selected 122 and averaged 124 to produce baseline data 126. The further normalized data 120 are then divided 128 by the baseline data to yield baseline corrected data 130. These baseline samples are selected so as to be before the PCR growth exceeds the nearly horizontal base line portion of the curve in FIG. 7. Selected baseline cycles may be, for example, cycles 6 through 15. After further normalization 118, the further normalized data 118 are used to compute 98 DNA concentration 96.

30

The trend (e.g. least squares regression line) of these same baseline samples is subtracted from the normalized extension cycle data, to produce data that has a flat base line at zero.

5 This data set may then be processed using established or other desired PCR methods to calculate the amount of starting copies of DNA. A simple procedure is to extrapolate for the inflection point at the transition from flat to rising. A more sophisticated procedure is described in the aforementioned U.S. patent No. 5,766,889.

10 The data may be used for various purposes, for example quantitative monitoring of the reaction or determination of replicated DNA concentration, or determination of the starting amount. The instrument also may be used (with or without normalizations and other corrections) simply to display whether replication is taking place during a sequence, or has taken place.

15 While the invention has been described above in detail with reference to specific embodiments, various changes and modifications which fall within the spirit of the invention and scope of the appended claims will become apparent to those skilled in this art. Therefore, the invention is intended only to be limited by the appended claims or their equivalents.

What is claimed is:

1. An optical instrument for monitoring polymerase chain reaction replication of DNA in a reaction apparatus that includes a thermal cycler block for holding at least one vial containing a suspension of ingredients for the reaction, the ingredients including a fluorescent primary dye that fluoresces proportionately in presence of DNA, the instrument comprising:

a light source for emitting a source beam having at least a primary excitation frequency that causes the primary dye to fluoresce at an emission frequency;

first means disposed to be receptive of the source beam to effect an excitation beam having the excitation frequency;

primary focusing means disposed to focus the excitation beam into each suspension such that the primary dye emits an emission beam having the emission frequency, the emission beam having an intensity representative of concentration of DNA in each suspension, the focusing means being receptive of and passing the emission beam;

second means disposed to be receptive of the emission beam from the focusing means so as to further pass the emission beam at the emission frequency;

emission focusing means for focusing the emission beam;

a detector disposed to be receptive of the emission beam from the second means and the emission focusing means such that the emission beam is focused onto the detector, the detector generating primary data signals representative of the emission beam and thereby a corresponding concentration of DNA in each vial; and

processing means receptive of the primary data signals for computing primary signal data and the corresponding concentration of DNA.

2. The instrument of claim 1 wherein the first means and the second means together comprise a beam splitter that is receptive of the source beam to effect the excitation beam, and receptive of the emission beam to pass the emission beam at the emission frequency to the detector.
3. The instrument of claim 2 wherein the beam splitter is disposed to reflect light having the excitation frequency and pass light having the emission frequency.
4. The instrument of claim 1 wherein the block is configured to hold a plurality of vials, the focusing means comprises a corresponding plurality of vial lenses each being disposed for positioning over a vial such that the emission beam comprises individual beams each associated with a vial, and the detector comprises an array of photoreceptors receptive of the individual beams to generate corresponding data signals such that the processing means computes concentration of DNA in each vial.

5. The instrument of claim 4 wherein the vials have transparent vial caps, the instrument further comprises a platen having holes therein aligned with the vial lenses so as to pass the individual beams and associated portions of the excitation beam therethrough, the platen being disposed for the holes to fit over the caps in contact therewith, and further comprises heating means for heating the platen sufficiently to prevent condensation under the caps without interfering with DNA replication in the vials.

6. The instrument of claim 4 wherein the focusing means further comprises a field lens disposed cooperatively with the vial lenses to effect focusing of the excitation beam into each suspension, and to pass the individual beams to the second means.

7. The instrument of claim 6 wherein the field lens is an aspherically corrected Fresnel lens.

8. The instrument of claim 6 wherein the emission focusing means comprises a detector lens disposed between the second means and the detector, the detector lens being cooperative with the vial lenses and the field lens to focus the individual beams on the detector.

9. The instrument of claim 8 further comprising a fluorescent reference emitter that emits reference light in response to the excitation beam, the reference emitter being disposed for the emission focusing means to focus at least a portion of the reference light as a reference

beam onto the detector, the detector being further receptive of the reference beam to generate a reference signal, and the processing means comprises means receptive of the reference signal for computing reference data, and means for normalizing the primary data with the reference data for a chosen point in the reaction replication of DNA, thereby correcting for instrument drift during the monitoring.

10. The instrument of claim 9 wherein the reference member comprises a plurality of reference emitters each emitting a reference beam of different intensity in response to the excitation beam, the reference emitters being disposed for the emission focusing means to focus each reference beam onto the detector, the detector being further receptive of each reference beam to generate a set of reference signals for each reference emitter, and the processing means comprises means receptive of the reference signals for computing corresponding sets of reference data, means for selecting from the sets the selected reference data that has the highest signal data less than a predetermined maximum, the selected reference data being used for normalizing the primary data.

11. The instrument of claim 1 wherein the first means further comprises an excitation filter, the second means further comprises an emission filter, and the first means and the second means together comprise a beam splitter, the excitation filter being disposed between the light source and the beam splitter, the emission filter being disposed between the beam splitter and the detector, the excitation filter passing light having the excitation frequency and substantially blocking light having the emission frequency, and the emission filter passing light having the emission frequency and substantially blocking light having

the excitation frequency, the excitation filter and the beam splitter being cooperatively receptive of the source beam to effect the excitation beam, and the emission filter and the beam splitter being cooperatively receptive of the emission beam to pass the emission beam having the emission frequency to the detector.

12. The instrument of claim 11 further comprising a housing containing the light source, the detector, the focusing means and a filter module, wherein the beam splitter, the excitation filter and the emission filter are affixed in the module and are associated with a selected primary dye for the suspension, and the module is removable from the housing for replacement with another module associated with another selected primary dye.

13. The instrument of claim 1 wherein the light source comprises a halogen lamp and an ellipsoid reflector disposed proximate to the lamp oppositely from the first means, the lamp being disposed at a focal distance from the ellipsoid reflector to effect the source beam with light reflected from the ellipsoid reflector, and the ellipsoid reflector substantially reflecting visible light and transmitting infrared light.

14. The instrument of claim 1 further comprising a fluorescent reference emitter that emits reference light in response to the excitation beam, the reference emitter being disposed for the emission focusing means to focus at least a portion of the reference light as a reference beam onto the detector, the detector being further receptive of the reference beam to generate a reference signal, and the processing means comprises means receptive of the reference signal for computing reference data, and means for normalizing the

primary data with the reference data for a chosen point in the reaction replication of DNA, thereby correcting for instrument drift during the monitoring.

15. The instrument of claim 14 wherein the reference member comprises a plurality of reference emitters each emitting a reference beam of different intensity in response to the excitation beam, the reference emitters being disposed for the emission focusing means to focus each reference beam onto the detector, the detector being further receptive of each reference beam to generate a set of reference signals for each reference emitter, and the processing means comprises means receptive of the reference signals for computing corresponding sets of reference data, means for selecting from the sets the selected reference data that has the highest signal data less than a predetermined maximum, the selected reference data being used for normalizing the primary data.

16. The instrument of claim 15 wherein the reference member comprises a plastic fluorescent strip and a neutral density filter mounted on the fluorescent strip such that the reference beam and a portion of the excitation beam are attenuated by the neutral density filter, the neutral density filter having a series of densities to effect the plurality of reference emitters each emitting a reference beam.

17. The instrument of claim 16 further comprising temperature means for maintaining the reference member at substantially constant temperature.

18. The instrument of claim 17 wherein the temperature means comprises a heating strip mounted under the fluorescent strip, and means for controllably heating the heating strip.

19. The instrument of claim 1 further comprising a plurality of fluorescent reference emitters each emitting a reference beam of different intensity in response to the excitation beam, the reference emitters being disposed for the emission focusing means to focus each reference beam onto the detector, the detector being further receptive of each reference beam to generate a set of reference signals for each reference emitter, and the processing means comprises means receptive of the reference signals for computing corresponding sets of reference data, means for selecting from the sets the selected reference data that has the highest signal data less than a predetermined maximum, and means for normalizing the primary data with corresponding selected reference data for a chosen point in the reaction replication of DNA, thereby correcting for instrument drift during the monitoring.

20. The instrument of claim 1 wherein sets of data signals are generated sequentially in a replication sequence, the processing means or the detector or a combination thereof have a saturation limit for the data signals in each set, the detector is operatively connected to the processing means for the detector to integrate emission beam input over a preselected exposure time for generating each set of data signals, and the processing means comprises adjustment means for automatically effecting adjustments in exposure time to maintain the primary data within a predetermined operating range for maintaining corresponding data signals less than the saturation limit, and means for correcting the primary data in proportion to the adjustments in exposure time.

21. The instrument of claim 20 wherein the detector comprises an array of photoreceptors receptive of the emission beam for generating corresponding data signals in an associated exposure time, the predetermined operating range is for each photoreceptor, and the processing means further comprises means for computing photoreceptor data from the data signals for each photoreceptor, and the adjustment means comprises means for ascertaining highest photoreceptor data, means for determination of whether the highest photoreceptor data are less than, within or higher than the predetermined operating range, and means based on such determination for respectively increasing, retaining or reducing the exposure time so as to effect a subsequent exposure time for maintaining subsequent photoreceptor data within the predetermined operating range.

22. The instrument of claim 1 further comprising a plurality of fluorescent reference emitters each emitting a reference beam of different intensity in response to the excitation beam, the reference emitters being disposed for the emission focusing means to focus each reference beam onto the detector, the detector being further receptive of each reference beam to generate a set of reference signals for each reference emitter, and the processing means comprises means receptive of the reference signals for computing corresponding sets of reference data, means for selecting from the sets the selected reference data that has the highest signal data less than a predetermined maximum, and means for normalizing the primary data with corresponding selected reference data for a chosen point in the reaction replication of DNA, thereby correcting for instrument drift during the monitoring.

23. The instrument of claim 20 wherein the ingredients for at a vial further include a standard concentration of fluorescent passive dye that fluoresces substantially without influence from DNA, the source beam includes a secondary excitation frequency that causes the passive dye to fluoresce at a secondary emission frequency and thereby emit a secondary emission beam passed by the second means and focused onto the detector to generate corresponding secondary data signals, the processing means further comprises means receptive of the secondary data signals for computing secondary data, and means for dye normalizing the primary data, whereby the computed concentration of DNA is normalized to the standard concentration of passive dye.

24. The instrument of claim 23 wherein the secondary excitation frequency is identical to the primary excitation frequency, the passive dye fluoresces such that the secondary beam is substantially at the emission frequency, the primary data signals are generated during an extension phase of cycling of the thermal cycler block when DNA is recombined and correspondingly primary dye emission is maximized, and the secondary data signals are generated during a denature phase of cycling of the thermal cycler block when DNA is denatured and correspondingly primary dye emission is minimized, whereby data signals for the extension phase are substantially representative of DNA concentration and data signals for the denature phase are substantially representative of the standard concentration of passive dye.

25. The instrument of claim 1 wherein the ingredients for a vial further include a standard concentration of fluorescent passive dye that fluoresces substantially without influence

from DNA, the source beam includes a secondary excitation frequency that causes the passive dye to fluoresce at a secondary emission frequency and thereby emit a secondary emission beam passed by the second means and focused onto the detector to generate corresponding secondary data signals, the processing means comprises means receptive of the secondary data signals for computing secondary data, and means for dye normalizing the primary data, whereby the computed concentration of DNA is normalized to the standard concentration of passive dye.

26. The instrument of claim 25 wherein the secondary excitation frequency is identical to the primary excitation frequency, the passive dye fluoresces such that the secondary beam is substantially at the emission frequency, the primary data signals are generated during an extension phase of cycling of the thermal cycler block when DNA is recombined and correspondingly primary dye emission is maximized, and the secondary data signals are generated during a denature phase of cycling of the thermal cycler block when DNA is denatured and correspondingly primary dye emission is minimized, whereby data signals for the extension phase are substantially representative of DNA concentration and data signals for the denature phase are substantially representative of the standard concentration of passive dye.

27. A system for replication of DNA and monitoring thereof, comprising a reaction apparatus for polymerase chain reaction replication of DNA, and an optical instrument for monitoring presence of DNA during such replication, wherein the apparatus comprises a thermal cycler block for holding at least one vial containing a suspension of ingredients for

the reaction, the ingredients including a fluorescent dye that fluoresces proportionately in presence of DNA, and further comprises means for thermal cycling the block and thereby the suspension so as to effect the polymerase chain reaction; wherein the instrument comprises:

a light source for emitting a source beam having at least an excitation frequency that causes the dye to fluoresce at an emission frequency;

first means disposed to be receptive of the source beam to effect an excitation beam having the excitation frequency and to pass the excitation beam to a focusing means, the focusing means being for focusing the excitation beam into each suspension such that the dye emits an emission beam having the emission frequency, and for passing the emission beam to a second means, the second means being for further passing the emission beam to a detector, the detector being disposed to be receptive of the emission beam from the second means so as to generate data signals representative of the emission beam and thereby concentration of DNA; and

processing means receptive of the data signals for computing and displaying the concentration of DNA.

28. The system of claim 27 wherein the first means and the second means together comprise a beam splitter receptive of the source beam to effect the excitation beam, and receptive of the emission beam to pass the emission beam to the detector.

29. A filter module for an optical instrument that monitors polymerase chain reaction replication of DNA in a reaction apparatus that includes a thermal cycler block for holding at least one vial containing a suspension of ingredients for the reaction, the ingredients including a fluorescent dye that fluoresces proportionately in presence of DNA, the instrument including a housing, a light source disposed in the housing for emitting a source beam having at least an excitation frequency that causes the dye to fluoresce at an emission frequency, focusing means disposed in the housing for focusing an excitation beam having the excitation frequency into each suspension such that the dye emits an emission beam having the emission frequency, a detector disposed in the housing to be receptive of the emission beam so as to generate data signals representative of the emission beam and thereby concentration of DNA, and processing means receptive of the data signals for computing and displaying the concentration of DNA; wherein the module comprises:

a support frame, the instrument being receptive of the support frame into the instrument;

a beam splitter affixed in the support frame so that, with the module inserted, the beam splitter is receptive of the source beam so as to effect the excitation beam, and receptive of the emission beam to pass the emission beam to the detector;

an excitation filter that passes light having the excitation frequency and substantially blocks light having the emission frequency, the excitation filter being affixed in the support

frame so that, with the module inserted, the excitation filter is disposed between the light source and the beam splitter; and

an emission filter that passes light having the emission frequency and substantially blocks light having the excitation frequency, the emission filter being affixed in the support frame so that, with the module inserted, the emission filter is disposed between the detector and the beam splitter;

the beam splitter, the excitation filter and the emission filter, and thereby the module, being associated with a selected dye for the suspension, and the module being removable from the housing for replacement with another module associated with another selected dye.

30. The module of claim 29 wherein the beam splitter reflects light having an excitation frequency, and passes light having the emission frequency.

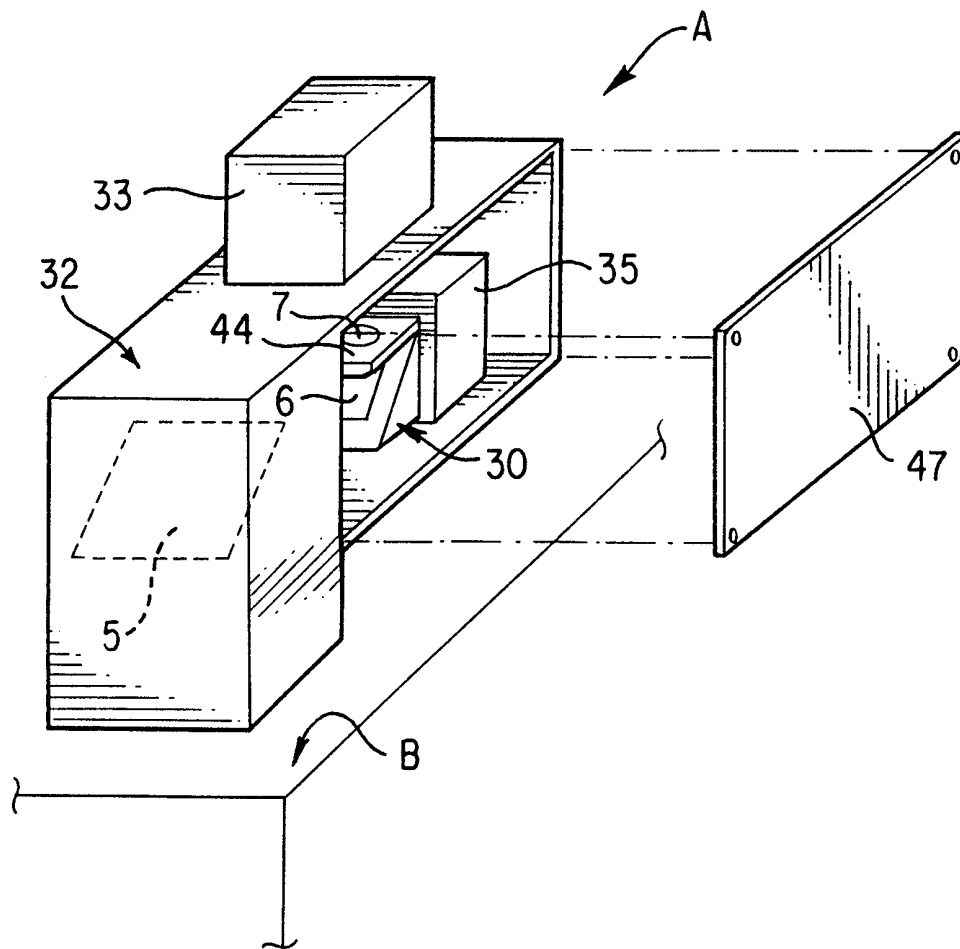

FIG. 2

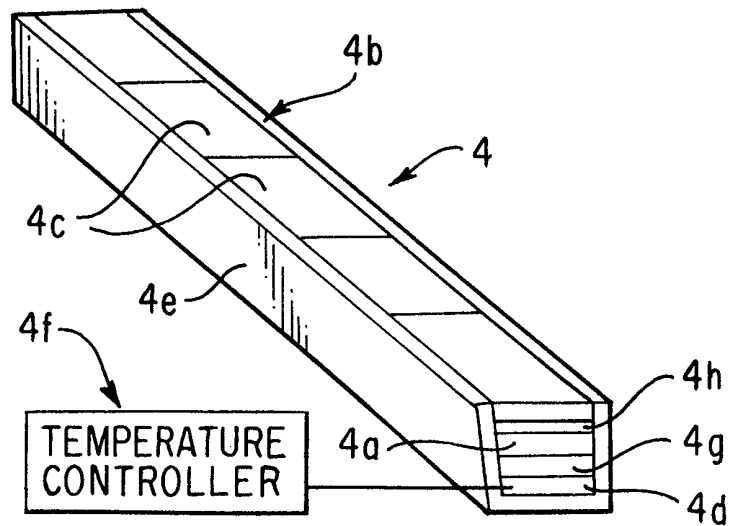
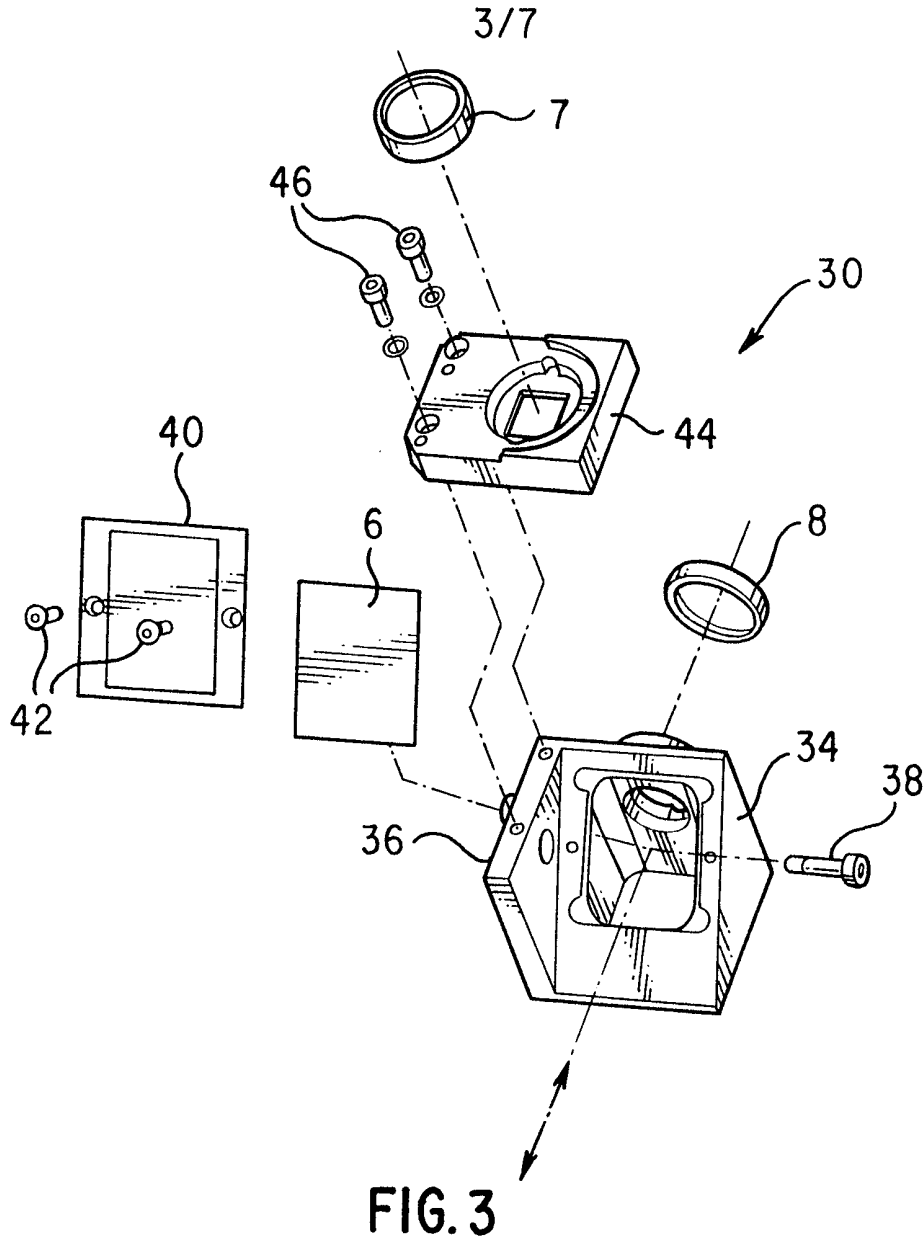

FIG. 4
SUBSTITUTE SHEET (RULE 26)

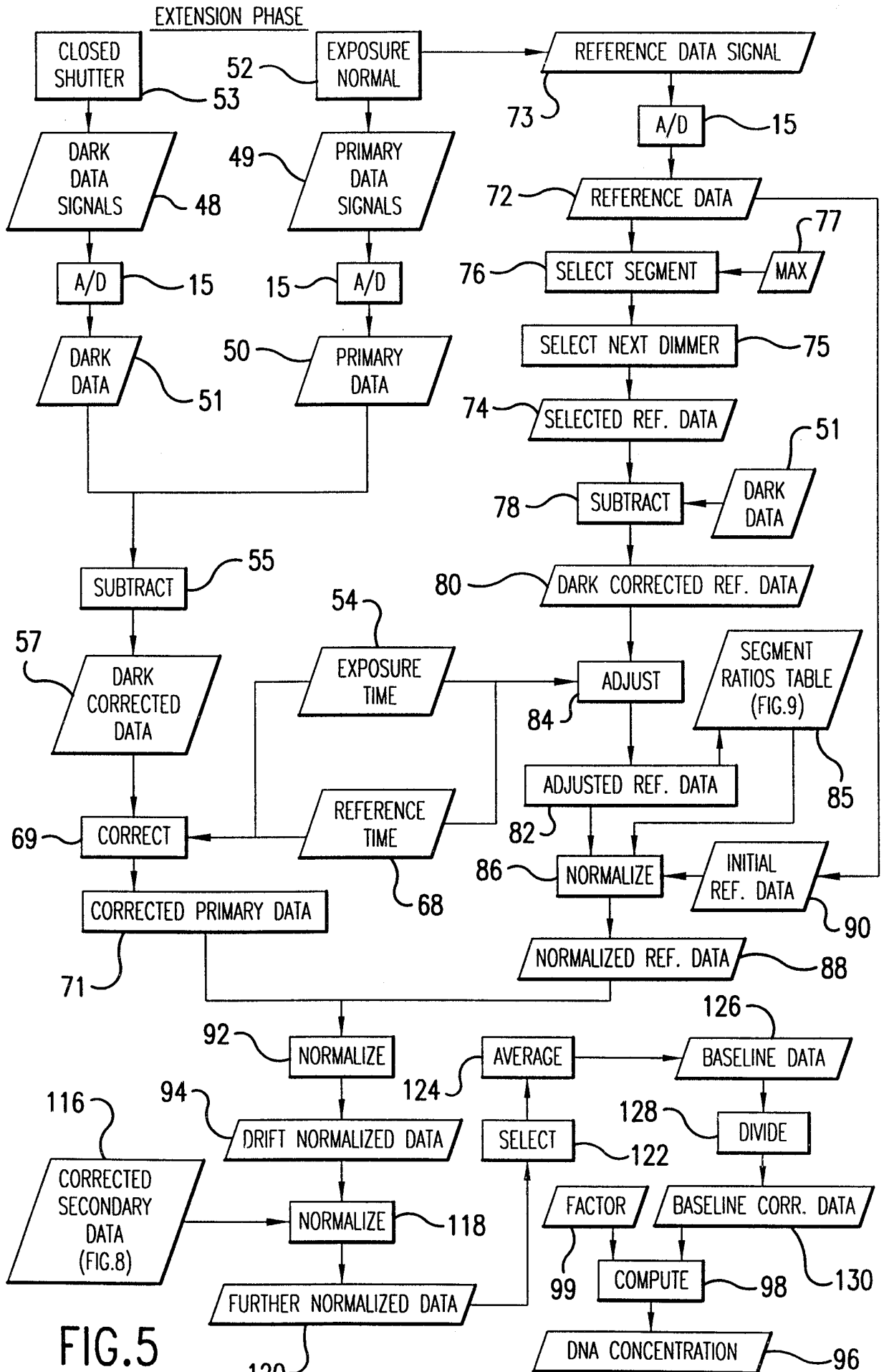

FIG. 5

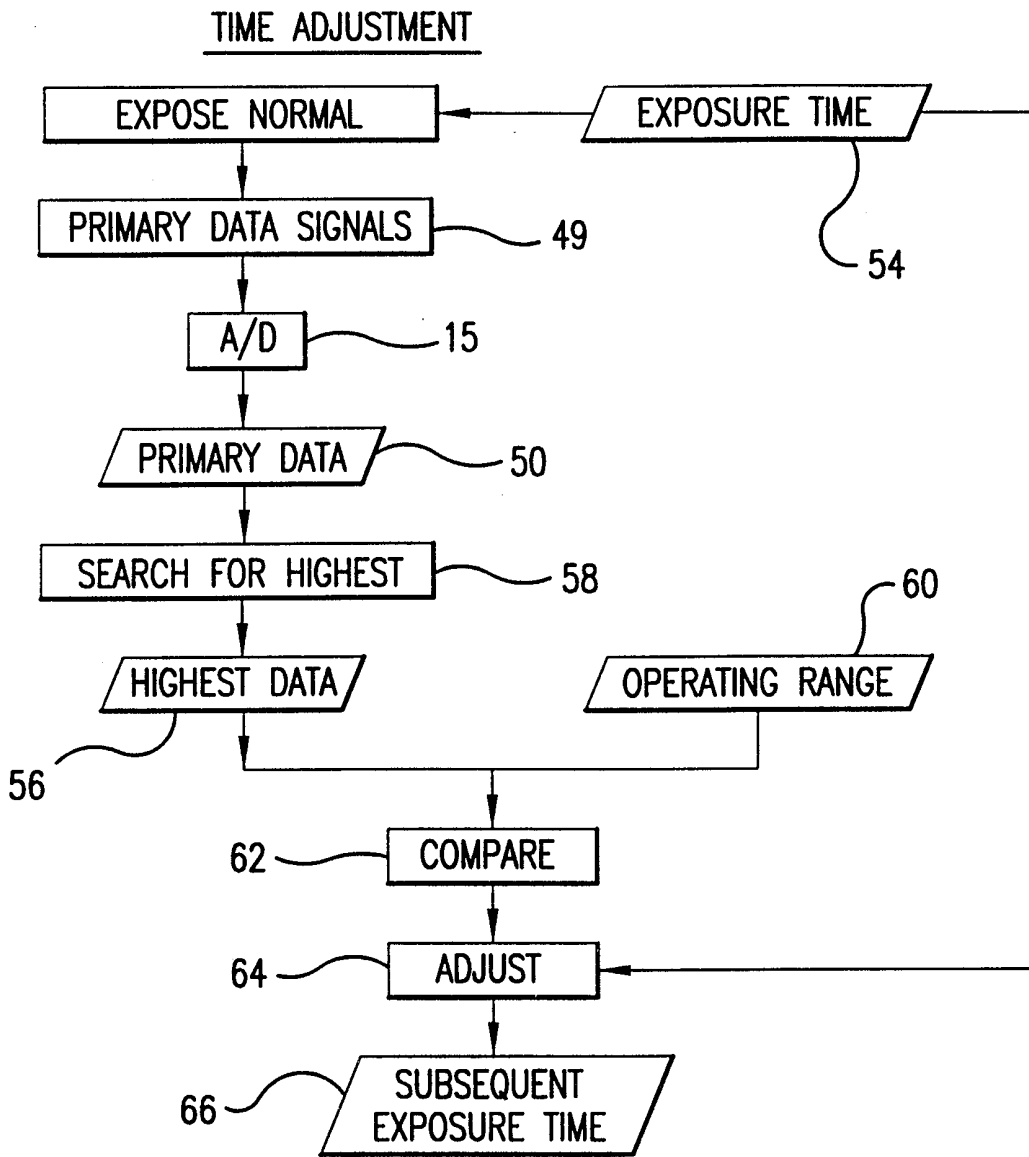

FIG.6

6/7

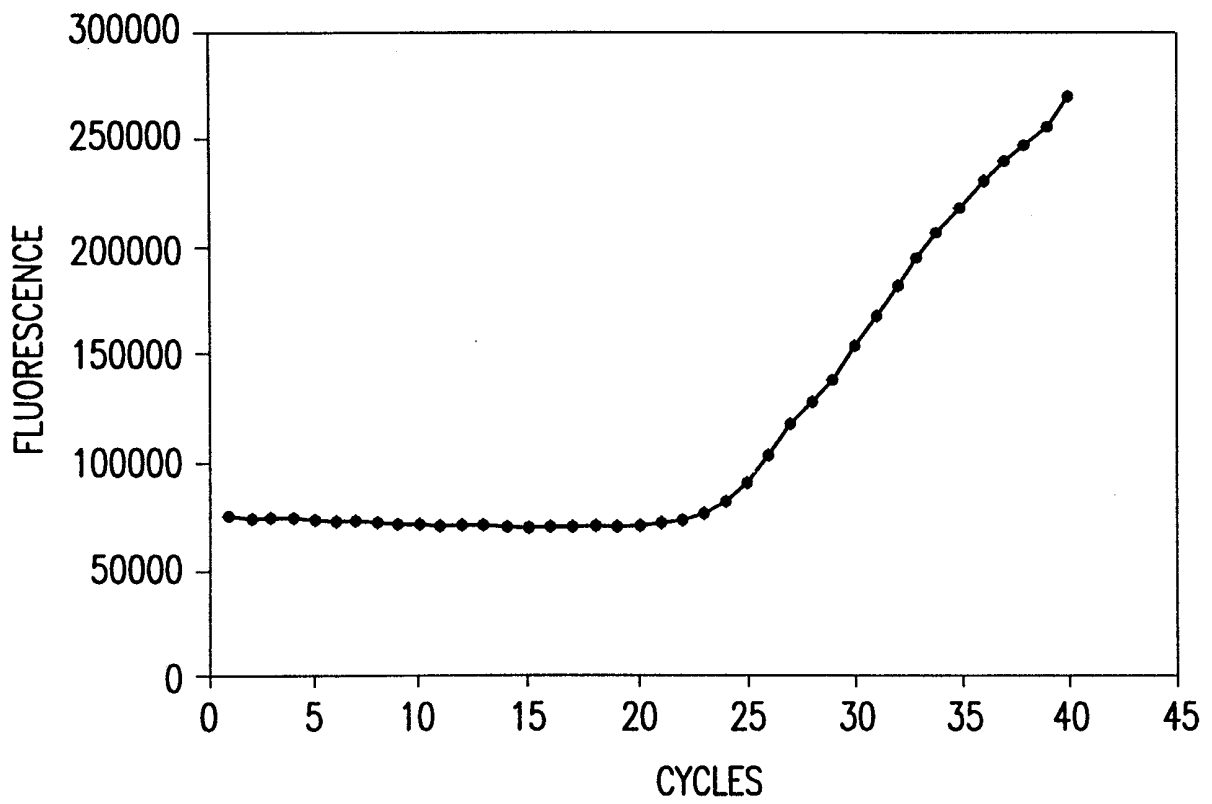

FIG. 7

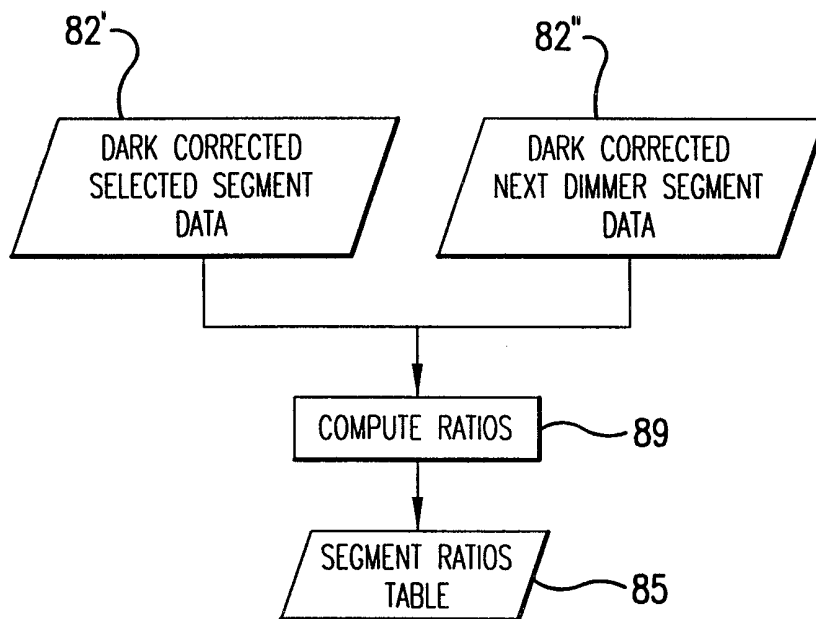

FIG. 9

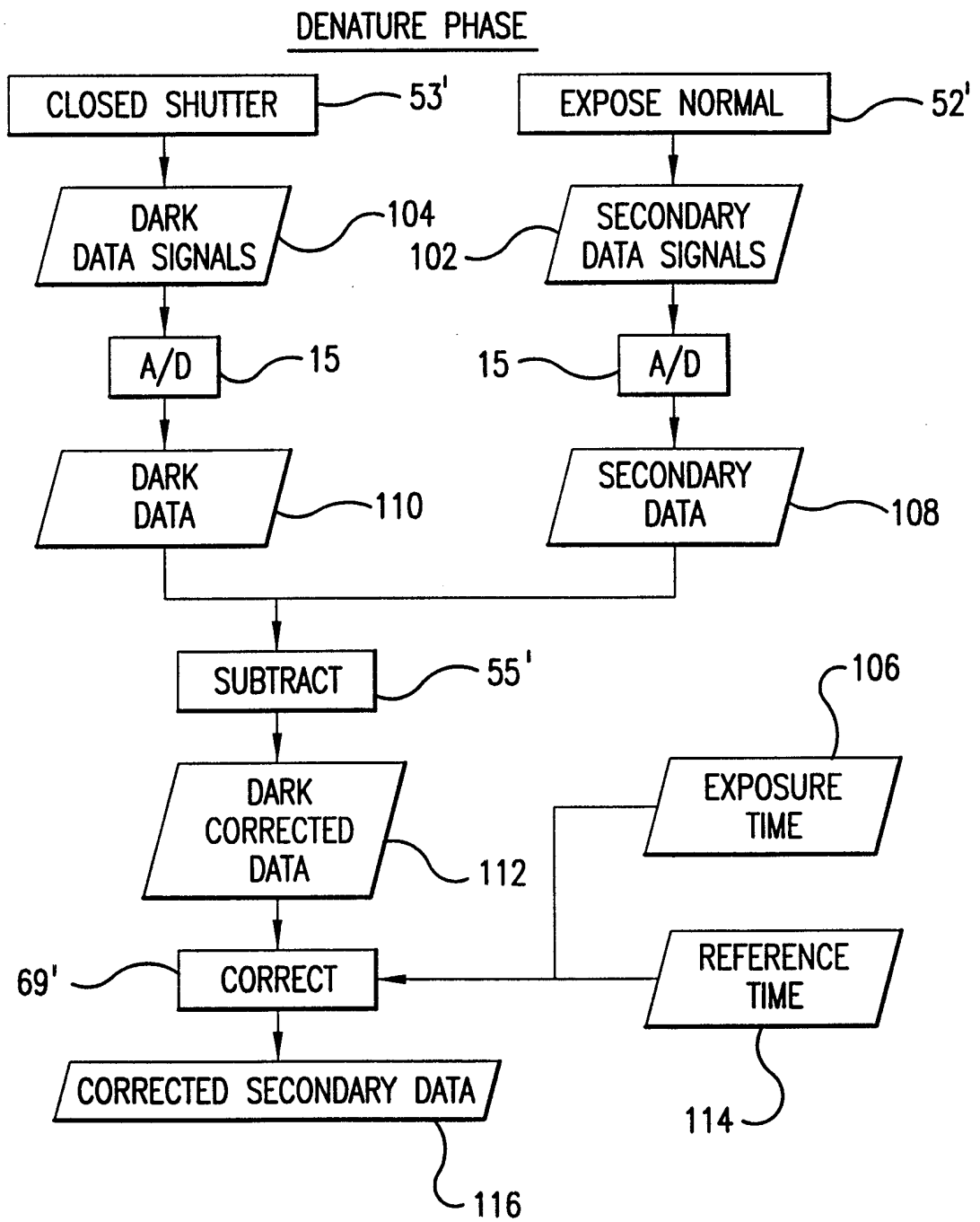

FIG.8

INTERNATIONAL SEARCH REPORT

International Application No

PCT/US 99/11088

A. CLASSIFICATION OF SUBJECT MATTER
 IPC 6 G01N21/25 C12Q1/68

According to International Patent Classification (IPC) or to both national classification and IPC

B. FIELDS SEARCHED

Minimum documentation searched (classification system followed by classification symbols)
 IPC 6 G01N C12Q

Documentation searched other than minimum documentation to the extent that such documents are included in the fields searched

Electronic data base consulted during the international search (name of data base and, where practical, search terms used)

C. DOCUMENTS CONSIDERED TO BE RELEVANT

Category	Citation of document, with indication, where appropriate, of the relevant passages	Relevant to claim No.
Y	US 5 736 333 A (MCBRIDE LINCOLN J ET AL) 7 April 1998 (1998-04-07) figures 1,2 ---	1-30
Y	EP 0 640 828 A (HOFFMANN LA ROCHE) 1 March 1995 (1995-03-01) figure 15 ---	1-30
A	WO 97 23649 A (BIORAD LAB INC) 3 July 1997 (1997-07-03) figure 1 ---	1-30
A	WO 97 46707 A (RASMUSSEN RANDY P ;UNIV UTAH RES FOUND (US); RIRIE KIRK M (US); WI) 11 December 1997 (1997-12-11) figure 11 ---	1-30
	-/--	

Further documents are listed in the continuation of box C.

Patent family members are listed in annex.

° Special categories of cited documents :

- "A" document defining the general state of the art which is not considered to be of particular relevance
- "E" earlier document but published on or after the international filing date
- "L" document which may throw doubts on priority claim(s) or which is cited to establish the publication date of another citation or other special reason (as specified)
- "O" document referring to an oral disclosure, use, exhibition or other means
- "P" document published prior to the international filing date but later than the priority date claimed

- "T" later document published after the international filing date or priority date and not in conflict with the application but cited to understand the principle or theory underlying the invention
- "X" document of particular relevance; the claimed invention cannot be considered novel or cannot be considered to involve an inventive step when the document is taken alone
- "Y" document of particular relevance; the claimed invention cannot be considered to involve an inventive step when the document is combined with one or more other such documents, such combination being obvious to a person skilled in the art.
- "&" document member of the same patent family

Date of the actual completion of the international search

26 August 1999

Date of mailing of the international search report

15/09/1999

Name and mailing address of the ISA
 European Patent Office, P.B. 5818 Patentlaan 2
 NL - 2280 HV Rijswijk
 Tel. (+31-70) 340-2040, Tx. 31 651 epo nl,
 Fax: (+31-70) 340-3016

Authorized officer

 Mason, W

INTERNATIONAL SEARCH REPORT

International Application No

PCT/US 99/11088

C.(Continuation) DOCUMENTS CONSIDERED TO BE RELEVANT		
Category	Citation of document, with indication, where appropriate, of the relevant passages	Relevant to claim No.
A	EP 0 622 455 A (BECTON DICKINSON CO) 2 November 1994 (1994-11-02) figures 1,5 -----	1-30

INTERNATIONAL SEARCH REPORT

Information on patent family members

International Application No

PCT/US 99/11088

Patent document cited in search report		Publication date	Patent family member(s)	Publication date
US 5736333	A	07-04-1998	AU 3230297	A 05-01-1998
			CA 2256457	A 11-12-1997
			EP 0904411	A 31-03-1999
			WO 9746708	A 11-12-1997
EP 0640828	A	01-03-1995	AU 681682	B 04-09-1997
			AU 7141494	A 09-03-1995
			BR 9403338	A 11-04-1995
			CA 2129787	A 28-02-1995
			CN 1107892	A 06-09-1995
			CZ 9402078	A 15-11-1995
			FI 943936	A 28-02-1995
			HU 71622	A 29-01-1996
			IL 110732	A 15-07-1998
			JP 7163397	A 27-06-1995
			NO 943166	A 28-02-1995
			NZ 264310	A 25-03-1998
			PL 304805	A 06-03-1995
			SG 47865	A 17-04-1998
			ZA 9406330	A 28-02-1995
WO 9723649	A	03-07-1997	US 5792610	A 11-08-1998
			AU 1423597	A 17-07-1997
			CA 2241364	A 03-07-1997
			EP 0874912	A 04-11-1998
			EP 0879297	A 25-11-1998
			WO 9723648	A 03-07-1997
			US 5759781	A 02-06-1998
WO 9746707	A	11-12-1997	AU 3154797	A 05-01-1998
			AU 3380097	A 05-01-1998
			AU 3481297	A 05-01-1998
			CA 2256773	A 11-12-1997
			EP 0912760	A 06-05-1999
			EP 0906449	A 07-04-1999
			EP 0912766	A 06-05-1999
			WO 9746712	A 11-12-1997
WO 9746714	A 11-12-1997			
EP 0622455	A	02-11-1994	US 5371016	A 06-12-1994
			AU 668278	B 26-04-1996
			AU 5919894	A 27-10-1994
			BR 9401570	A 22-11-1994
			CA 2120993	A 27-10-1994
			JP 2738500	B 08-04-1998
			JP 6319524	A 22-11-1994