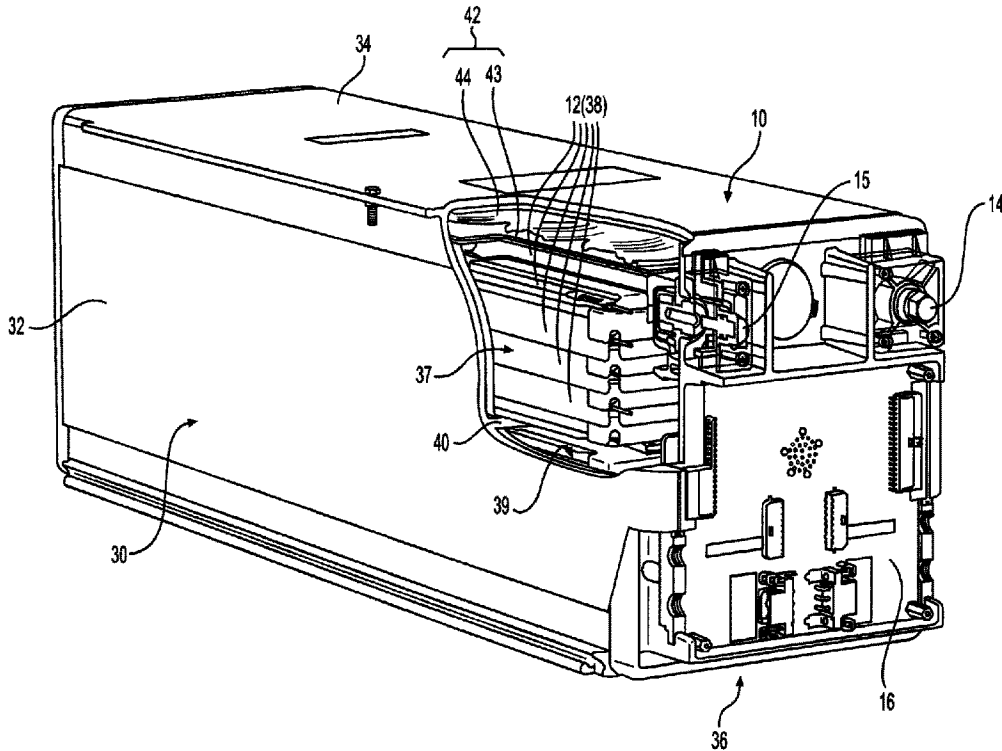




(86) Date de dépôt PCT/PCT Filing Date: 2016/12/12  
 (87) Date publication PCT/PCT Publication Date: 2017/06/15  
 (45) Date de délivrance/Issue Date: 2024/02/13  
 (85) Entrée phase nationale/National Entry: 2018/06/08  
 (86) N° demande PCT/PCT Application No.: CA 2016/000310  
 (87) N° publication PCT/PCT Publication No.: 2017/096463  
 (30) Priorité/Priority: 2015/12/11 (US62/266,026)

(51) Cl.Int./Int.Cl. *H01M 10/613* (2014.01),  
*H01M 10/052* (2010.01), *H01M 10/0585* (2010.01),  
*H01M 10/0587* (2010.01), *H01M 10/66* (2014.01)  
 (72) Inventeurs/Inventors:  
 COTTON, FREDERIC, CA;  
 REBOUL-SALZE, CEDRIC, CA;  
 LEBLANC, PATRICK, CA;  
 GUENA, THIERRY, CA;  
 VALLEE, ALAN, CA  
 (73) Propriétaire/Owner:  
 BLUE SOLUTIONS CANADA INC., CA  
 (74) Agent: BCF LLP

(54) Titre : BATTERIE A CELLULES ELECTROCHIMIQUES A IMPEDANCE VARIABLE  
 (54) Title: BATTERY WITH ELECTROCHEMICAL CELLS HAVING VARIABLE IMPEDANCE



(57) **Abrégé/Abstract:**

A lithium battery comprising a plurality of electrochemical cells assembled together which are inserted in a rigid casing having side walls and upper and lower walls forming an enclosure; and at least one heat sink path to dissipate excess heat generated by the electrochemical cells; the electrochemical cells are assembled such that the electrochemical cells positioned adjacent to the heat sink path have a lower impedance than the other electrochemical cells of the battery.

(12) INTERNATIONAL APPLICATION PUBLISHED UNDER THE PATENT COOPERATION TREATY (PCT)

(19) World Intellectual Property  
Organization  
International Bureau(43) International Publication Date  
15 June 2017 (15.06.2017)(10) International Publication Number  
**WO 2017/096463 A1**

## (51) International Patent Classification:

*H01M 10/613* (2014.01)    *H01M 10/0587* (2010.01)  
*H01M 10/052* (2010.01)    *H01M 10/66* (2014.01)  
*H01M 10/0585* (2010.01)    *H01M 2/02* (2006.01)

## (21) International Application Number:

PCT/CA2016/000310

## (22) International Filing Date:

12 December 2016 (12.12.2016)

## (25) Filing Language:

English

## (26) Publication Language:

English

## (30) Priority Data:

62/266,026    11 December 2015 (11.12.2015)    US

(71) Applicant: **BLUE SOLUTIONS CANADA INC.**  
 [CA/CA]; 1600 de Coulomb Street, Boucherville, Quebec  
 J4B 7Z7 (CA).

(72) Inventors: **COTTON, Frederic**; 7181 Molson Street,  
 Montreal, Quebec H2A 3K5 (CA). **REBOUL-SALZE,**  
**Cedric**; 73 Mont-Royal Avenue Est Apt 2, Montreal, Que-  
 bec H2T 1N4 (CA). **LEBLANC, Patrick**; 343 d'Alsace  
 Street, Boucherville, Quebec J4B 8K5 (CA). **GUENA,**  
**Thierry**; 87 rue Cuvillier, Longueuil, Quebec J4L 4N4  
 (CA). **VALLEE, Alain**; 22 rue des Embruns, Varennes,  
 Quebec J3X 2A2 (CA).

(74) Agent: **BIRD, Keith**; McMillan LLP, Brookfield Place,  
 181 Bay Street, Suite 4400, Toronto, Ontario M5J 2T3  
 (CA).

(81) Designated States (*unless otherwise indicated, for every  
 kind of national protection available*): AE, AG, AL, AM,  
 AO, AT, AU, AZ, BA, BB, BG, BH, BN, BR, BW, BY,  
 BZ, CA, CH, CL, CN, CO, CR, CU, CZ, DE, DJ, DK, DM,  
 DO, DZ, EC, EE, EG, ES, FI, GB, GD, GE, GH, GM, GT,  
 HN, HR, HU, ID, IL, IN, IR, IS, JP, KE, KG, KH, KN,  
 KP, KR, KW, KZ, LA, LC, LK, LR, LS, LU, LY, MA,  
 MD, ME, MG, MK, MN, MW, MX, MY, MZ, NA, NG,  
 NI, NO, NZ, OM, PA, PE, PG, PH, PL, PT, QA, RO, RS,  
 RU, RW, SA, SC, SD, SE, SG, SK, SL, SM, ST, SV, SY,  
 TH, TJ, TM, TN, TR, TT, TZ, UA, UG, US, UZ, VC, VN,  
 ZA, ZM, ZW.

(84) Designated States (*unless otherwise indicated, for every  
 kind of regional protection available*): ARIPO (BW, GH,  
 GM, KE, LR, LS, MW, MZ, NA, RW, SD, SL, ST, SZ,  
 TZ, UG, ZM, ZW), Eurasian (AM, AZ, BY, KG, KZ, RU,  
 TJ, TM), European (AL, AT, BE, BG, CH, CY, CZ, DE,  
 DK, EE, ES, FI, FR, GB, GR, HR, HU, IE, IS, IT, LT, LU,  
 LV, MC, MK, MT, NL, NO, PL, PT, RO, RS, SE, SI, SK,  
 SM, TR), OAPI (BF, BJ, CF, CG, CI, CM, GA, GN, GQ,  
 GW, KM, ML, MR, NE, SN, TD, TG).

## Published:

— with international search report (Art. 21(3))

(54) Title: BATTERY WITH ELECTROCHEMICAL CELLS HAVING VARIABLE IMPEDANCE

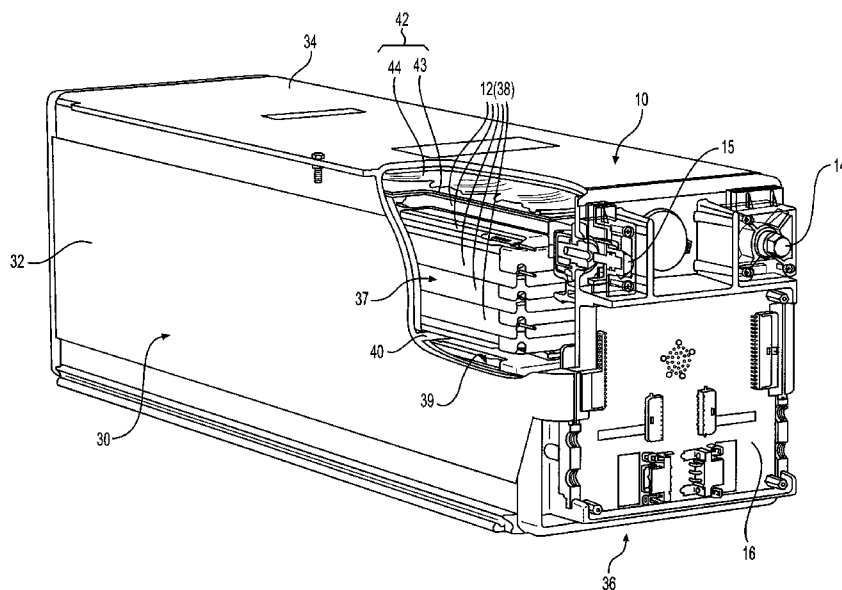


FIG. 1

(57) Abstract: A lithium battery comprising a plurality of electrochemical cells assembled together which are inserted in a rigid casing having side walls and upper and lower walls forming an enclosure; and at least one heat sink path to dissipate excess heat generated by the electrochemical cells; the electrochemical cells are assembled such that the electrochemical cells positioned adjacent to the heat sink path have a lower impedance than the other electrochemical cells of the battery.



WO 2017/096463 A1

## BATTERY WITH ELECTROCHEMICAL CELLS HAVING VARIABLE IMPEDANCE

### FIELD OF THE INVENTION

[0001] The present invention relates to a lithium polymer battery operating at temperatures and more specifically to a battery having an electrochemical cell configuration adapted to manage these operating temperatures.

### BACKGROUND OF THE INVENTION

[0002] Lithium polymer batteries are typically built as large format batteries of 20kWh or more for use in electric vehicle, in stationary applications for back-up to ensure continuity to applications that cannot afford a grid power outage such as telecommunication stations, data centers, etc., or to provide alternate power source for peak shaving purposes in industrial or residential buildings.

[0003] Lithium polymer batteries consist of a plurality of electrochemical cells connected in series enclosed in a rigid casing which protect the electrochemical cells. Each electrochemical cell includes a plurality of elementary cell laminates connected in parallel. Each laminate includes an anode or negative electrode, a cathode or positive electrode, and a solid electrolyte comprising a polymer and a lithium salt separating the positive electrode from the negative electrode and providing ionic conductivity between the electrodes. The negative electrode may be a lithium or lithium alloy metal sheet or an active material capable of insertion and de-insertion of lithium ions such as carbon or  $\text{Li}_4\text{Ti}_5\text{O}_{12}$  in a polymer binder while the positive electrode consists of electrochemically active material particles such as  $\text{LiFePO}_4$ ,  $\text{LiMnO}_2$ ,  $\text{LiMn}_2\text{O}_4$ , etc., an electronically conductive additive and a solid polymer electrolyte which acts as a binder as well as provides the required ionic path between the electrochemically active material particles of the positive electrode and the solid electrolyte separator.

[0004] Contrary to lithium ion batteries which use a liquid electrolyte, lithium polymer batteries uses a solid electrolyte rendering this technology extremely safe. However, to obtain optimal ionic conductivity and therefore optimal performance, the electrochemical cells must be heated to temperatures of 60°C to 80°C. Lithium

polymer batteries therefore include a heating system to maintain the battery at a nominal temperature of 40°C and to rapidly raise the temperature of the electrochemical cells to between 60°C and 80°C at the beginning of their discharge mode to obtain optimal performance from the battery. Once the optimal temperature is reached, the discharge operation generates sufficient heat to maintain the battery at its optimal temperature.

[0005] In operation, the excess heat generated by the plurality of electrochemical cells making up the battery is dissipated through the walls of the battery casing. The battery casing is preferably made of a rigid and heat conductive material such as aluminum or alloy thereof that efficiently conducts the excess heat outside the battery casing and there may be a cooling system outside the battery casing to accelerate heat dissipation when require.

[0006] In normal discharge operation, it was found that in a stack of electrochemical cells encased in a battery casing as described above, the electrochemical cells located adjacent to the walls of the battery casing were the first to reach their end of discharge voltage thereby marginally lowering the overall discharge capacity of the battery. This phenomena was attributed to the fact that these particular electrochemical cells were operating at slightly lower operating temperatures because they were losing heat more rapidly through the walls of the battery casing than the other electrochemical cells located farther away from the walls of the battery casing

[0007] Thus, there is a need for a battery casing and electrochemical cells configurations adapted to compensate for heat loss through heat sinks of the battery casing.

#### SUMMARY OF THE INVENTION

[0008] It is an object of the present invention to ameliorate at least some of the inconveniences present in the prior art.

[0009] In one aspect, the invention provides a lithium battery comprising a plurality of electrochemical cells assembled together which are inserted in a rigid casing having side walls and upper and lower walls forming an enclosure; and at least

one heat sink path to dissipate excess heat generated by the electrochemical cells; the electrochemical cells are assembled such that the electrochemical cells positioned adjacent to the heat sink path have a lower impedance than the other electrochemical cells of the battery.

[0010] In a further aspect, the electrochemical cells positioned adjacent to the heat sink path include laminates in which the electrolyte and the cathode have more salts than the other electrochemical cells of the bundle.

[0011] In a further aspect, the electrolyte and the cathode of the electrochemical cells positioned adjacent to the heat sink path each have a polymer/salt ratio approximately 5:1 inferior to the other electrochemical cells.

[0012] Embodiments of the present invention each have at least one of the above-mentioned objects and/or aspects, but do not necessarily have all of them. It should be understood that some aspects of the present invention that have resulted from attempting to attain the above-mentioned objects may not satisfy these objects and/or may satisfy other objects not specifically recited herein.

[0013] Additional and/or alternative features, aspects, and advantages of embodiments of the present invention will become apparent from the following description and the accompanying drawings.

#### BRIEF DESCRIPTION OF THE DRAWINGS

[0014] For a better understanding of the present invention, as well as other aspects and further features thereof, reference is made to the following description which is to be used in conjunction with the accompanying drawings, where:

[0015] Figure 1 is a perspective view of an example of a battery comprising a plurality of electrochemical cells;

[0016] Figure 2 is a schematic view of a single electrochemical cell laminate;

[0017] Figure 3 is a schematic view of one embodiment of a battery having a bundle of electrochemical cells numbered 1 to 14 enclosed in a rigid casing;

[0018] Figure 4 is a graph of the voltage of each electrochemical cell numbered 1 to 14 at the end of a discharge of the battery shown in Figure 3;

[0019] Figure 5 is a schematic view of second embodiment of a battery having two bundles of electrochemical cells numbered 1 to 14 enclosed in a rigid casing;

[0020] Figure 6 is a graph of the voltage of each electrochemical cell numbered 1 to 14 at the end of a discharge of the battery shown in Figure 5;

[0021] Figure 7 is a graph showing the voltage of each electrochemical cell numbered 1 to 14 at the end of a discharge of the battery shown in Figure 3 with a modified configuration;

[0022] Figure 8 is a graph showing the voltage of each electrochemical cell numbered 1 to 14 at the end of a discharge of the battery shown in Figure 5 with a modified configuration;

[0023] Figure 9 is a schematic view of third embodiment of a battery having three bundles of electrochemical cells numbered 1 to 18 enclosed in a rigid casing;

[0024] Figure 10 is a graph of the voltage of each electrochemical cell numbered 1 to 18 at the end of a discharge of the battery shown in Figure 13;

[0025] Figure 11a is a schematic top plan view of another embodiment of a battery having a plurality of cylindrical electrochemical cells enclosed in a rigid casing;

[0026] Figure 11b is a schematic side elevational view of the battery shown in Figure 11a having a plurality of cylindrical electrochemical cells enclosed in a rigid casing; and

[0027] Figure 12 is a schematic top plan view of a single cylindrical electrochemical cell.

#### DETAILED DESCRIPTION OF THE PREFERRED EMBODIMENTS

[0028] FIG. 1 illustrates one embodiment of a lithium metal polymer battery 10, with a cut-away portion showing its internal components. In this specific example,

the battery 10 includes a plurality of electrochemical cells 12 stacked one against the other, connected together in series and connected to battery poles 14 and 15. The stack of electrochemical cells 12 is connected to an electronic control board 16 that controls the charge and discharge mode of the electrochemical cells 12 and monitors various parameters of the battery 10 including the tension or voltage of each individual electrochemical cell 12 at all-time as well as the temperature of the battery 10.

[0029] The battery 10 includes a rigid casing 30 made of extruded aluminum having side walls 32 and upper and lower walls 34 forming an enclosure 37. The stack of electrochemical cells 12 are assembled together to form a bundle 38 which is inserted into the enclosure 37 formed by the rigid casing 30 for protection and for thermally isolating the bundle 38 to maintain optimal temperatures of the electrochemical cells 12. In the illustrated embodiment of Figure 1, the rigid casing 30 further comprises an internal wall 40 extending the entire length of the rigid casing 30 providing added rigidity to the casing 30 and thereby forming two distinct enclosures 37 and 39 such that the battery 10 includes two bundles 38 of electrochemical cells 12, one inserted in each enclosure 37 and 39. Each bundle 38 is maintained under pressure by a pressure system 42 consisting of a series of springs 44 exerting a force on a plate 43 which applies an even pressure on the bundle 38.

[0030] The battery 10 includes a heating system (not shown) located along the side walls 32 of the rigid casing 30. The heating system provides heat to the bundles 37 and 39 through the side walls 32 of the rigid casing 30 to maintain the battery 10 at a nominal temperature of 40°C in floating mode and to rapidly raise the temperature of the electrochemical cells 12 to between 60°C and 80°C at the beginning of their discharge mode.

[0031] Once the discharge temperature has been reached, the upper and lower walls 34 and 36 and the internal wall 40 of the rigid casing 30 provides a heat sink path to dissipate excess heat generated by the bundles 37 and 39 of electrochemical cells 12 in order to prevent overheating of the electrochemical cells 12.

[0032] Each electrochemical cell 12 consists of a multi-layer assembly of single laminates 20 as illustrated schematically in FIG. 2. Each laminate 20 comprises

an anode 22 that acts as a lithium source, a cathode 26 having an electrochemically active material capable of occluding and releasing lithium ions and an electrolyte 24 separating the anode 22 from the cathode 26 and acting as a lithium ion carrier. The anode 22 and the cathode 26 are made of materials capable of reversible insertion of lithium ions. The anode 22 may be a metallic lithium foil or a composite material comprising, for example, carbon-based intercalation compounds and a polymer, copolymer or terpolymer binder supported on a metallic current collector (not shown). The cathode 26 is typically a composite mixture of transitional metal oxide or phosphate and a polymer, copolymer or terpolymer binder including a lithium salt dissolved therein in a ratio of 35:1, supported by a current collector 28. The electrolyte 24 consists essentially of a lithium salt dissolved in a polymer, copolymer or terpolymer in a ratio of 30:1.

[0033] Bundles of electrochemical cells 12 typically include a plurality of identical electrochemical cells 12 having the same number of laminates 20 and therefore having the same capacity. Figure 3 illustrates schematically an embodiment of a battery having a single bundle 38 including 14 electrochemical cells 12 numbered 1 to 14 enclosed in a rigid casing 30 having side walls 32 and upper and lower walls 34 and 36. Each electrochemical cell 12 has the same number of laminates 20 and the same capacity.

[0034] Figure 4 is a graph showing the voltage of each electrochemical cell 12 numbered 1 to 14 at the end of a discharge of the battery. There emerges from the graph of Figure 4 a profile indicating that electrochemical cells Nos. 1, 2 and 13, 14 have reached their end of discharge voltage more rapidly than electrochemical cells Nos. 3 to 12. Since the battery reaches its end of discharge voltage when one of the electrochemical cells 12 of the bundle 38 reaches its end of discharge, the battery stopped operating while a plurality of its electrochemical cells 12 were still within their voltage discharge operating window. The battery effectively stopped operating with capacity remaining.

[0035] Figure 5 illustrates schematically an embodiment of a battery having two bundles 38 enclosed in a rigid casing 30 having side walls 32, upper and lower walls 34 and 36 and an internal wall 40 defining two enclosures 37 and 39. The first bundle 38 located in enclosure 37 includes 7 electrochemical cells 12 numbered 1 to 7

and the second bundle 38 located in enclosure 39 includes 7 electrochemical cells 12 numbered 8 to 14. As in the previous embodiment described with reference to Figure 3, each electrochemical cell 12 of the two bundles 38 has the same number of laminates 20 and the same capacity.

[0036] Figure 6 is a graph showing the voltage of each electrochemical cell 12 numbered 1 to 7 and 8 to 14 at the end of a discharge of the battery. There emerges from the graph of Figure 6 a profile indicating that electrochemical cells Nos. 1, 2, 6 to 9 and 13, 14 have reached their end of discharge voltage more rapidly than electrochemical cells Nos. 3 to 5 and 10 to 12. Since the battery reaches its end of discharge voltage when one of the electrochemical cells 12 of the bundle 38 reaches its end of discharge voltage, the battery stopped operating while a plurality of its electrochemical cells 12 were still within their voltage discharge operating window. Again, the battery effectively stopped operating with capacity remaining.

[0037] There emerges from the graphs of Figures 4 and 6 that the electrochemical cells located close to the heat sinks provided by the upper and lower walls 34 and 36 and by the internal wall 40 reach their end of discharge voltage more rapidly than the electrochemical cells located farther away from those heat sinks. Since the discharge capacity of the electrochemical cells 12 is dependent upon the temperature of the electrochemical cells 12, it stands to reason that the electrochemical cells located close to the heat sinks i.e. upper and lower walls 34 and 36 and/or internal wall 40, have more difficulties remaining at their operating temperatures due to their proximity to heat sinks and therefore are colder and effectively have less capacity than the electrochemical cells located farther away from the heat sinks.

[0038] To alleviate this problem, the inventors have tested a new bundle assembly in which the electrochemical cells close to the heat sinks provided by the upper and lower walls 34 and 36 and/or to the internal wall 40 have a lower impedance than the other electrochemical cells located farther away from the heat sinks.

[0039] The solution to the problem of premature end of cycle of the electrochemical cells 12 located close to or adjacent to the heat sinks provided by the

upper and lower walls 34 and 36 and the internal wall 40, contemplated by the inventors was to increase the discharge capability at lower temperature of those electrochemical cells and lowering the impedance or internal resistance of those electrochemical cells by increasing the lithium salt concentration in the electrolyte 24 and cathode 26.

[0040] In one specific embodiment, the impedance of the electrochemical cells 12 is reduced by adding lithium salt in the electrolyte 24 and in the cathode 26 within each laminate 20 of those electrochemical cells 12 close to the heat sinks.

[0041] An electrochemical cell 12 in which each constituent laminate 20 is made of an electrolyte 24 having a polymer/lithium salt ratio of 25:1 instead of 30:1 and a cathode 26 having a polymer/lithium salt ratio of 30:1 instead of 35:1 or a polymer/salt ratio approximately 5:1 inferior to the electrolyte and cathode of the laminates of the other electrochemical cells of the bundle will have the same capacity as the other electrochemical cells but will perform better in discharge mode at lower temperature due to its lower impedance and this increased discharge capability should compensate for the lower temperature experienced by those electrochemical cells close to the heat sinks.

[0042] The inventors have therefore tested a new bundle configuration in which the electrochemical cells close to the heat sinks of the upper and lower walls 34 and 36 and/or to the internal wall 40 include laminates 20 made of an electrolyte 24 having a polymer/lithium salt ratio of 25:1 instead of 30:1 and a cathode 26 having a polymer/lithium salt ratio of 30:1 instead of 35:1. Referring back to Figure 3, a new bundle 38 was configured and assembled with electrochemical cells Nos. 1 to 14 having n laminates 20 but with electrochemical cells Nos. 1, 2 and 13, 14 including laminates 20 made of an electrolyte 24 having a polymer/lithium salt ratio of 25:1 instead of 30:1 and a cathode 26 having a polymer/lithium salt ratio of 30:1 instead of 35:1.

[0043] Figure 7 is a graph showing the voltage of each electrochemical cell numbered 1 to 14 at the end of a discharge of the battery. The graph shows that the profile of end of discharge voltage of the electrochemical cells Nos. 1 to 14 has levelled off as compared to the profile of the graph of Figure 4 and that

electrochemical cells Nos. 1, 2 and 13, 14 have reached their end of discharge voltage almost at the same time as electrochemical cells Nos. 3 to 12 which demonstrates that the increased discharge capability of electrochemical cells Nos. 1, 2 and 13, 14 at lower temperature due to the increased salt concentration in their electrolytes and cathodes has compensated for the lower temperature experienced by those electrochemical cells close to the heat sinks.

[0044] Referring back to Figure 5, similarly, two new bundles 38 were configured and assembled. The first bundle 38 was configured and assembled with electrochemical cells Nos. 1 to 7 having n laminates 20 but with electrochemical cells Nos. 1, 2 and 6, 7 including laminates 20 made of an electrolyte 24 having a polymer/lithium salt ratio of 25:1 instead of 30:1 and a cathode 26 having a polymer/lithium salt ratio of 30:1 instead of 35:1. The second bundle 38 was configured and assembled with electrochemical cells Nos. 8 to 14 having n laminates 20 but with electrochemical cells Nos. 8, 9 and 13, 14 including laminates 20 made of an electrolyte 24 having a polymer/lithium salt ratio of 25:1 instead of 30:1 and a cathode 26 having a polymer/lithium salt ratio of 30:1 instead of 35:1.

[0045] Figure 8 is a graph showing the voltage of each electrochemical cell numbered 1 to 14 at the end of a discharge of the battery. The graph shows that the profile of end of discharge voltage of the electrochemical cells Nos. 1 to 7 and 8 to 14 has levelled off as compared to the profile of the graph of Figure 6 and that electrochemical cells Nos. 1, 2, 6-9 and 13, 14 each having laminates made of an electrolyte and a cathode having a polymer/salt ratio approximately 5:1 inferior to the electrolyte and the cathode of the laminates of the other electrochemical cells of the bundle have reached their end of discharge voltage almost at the same time as electrochemical cells Nos. 3 to 12 which further demonstrates that the increased discharge capability at lower temperature of the electrochemical cells close to the heat sinks due to the increased salt concentration in their electrolytes and cathodes has compensated for the lower temperature experienced by those electrochemical cells.

[0046] Figure 9 illustrates schematically another embodiment of a battery having three bundles 60 enclosed in a rigid casing 30 having side walls 32, upper and lower walls 34 and 36 and two internal walls 62 and 63 defining three enclosures 64, 65 and 66. The first bundle 60 located in enclosure 64 includes six electrochemical

cells 12 numbered 1 to 6, the second bundle 60 located in enclosure 65 includes six electrochemical cells 12 numbered 7 to 12, and the third bundle 60 located in enclosure 66 includes six electrochemical cells 12 numbered 13 to 18. As in the previous embodiments described with reference to Figures 3 and 5, each electrochemical cell 12 of the two bundles 60 has the same number of laminates 20 and the same capacity.

[0047] Figure 10 is a graph showing the voltage of each electrochemical cell 12 numbered 1 to 6, 7 to 12 and 13 to 18 at the end of a discharge of the battery. There emerges from the graph of Figure 10 a profile indicating that electrochemical cells Nos. 1, 2, 5 to 8, 11 to 14 and 17, 18 have reached their end of discharge voltage more rapidly than electrochemical cells Nos. 3-4, 9-10, and 15-16. Since the battery reaches its end of discharge voltage when one of the electrochemical cells 12 of the bundle 38 reaches its end of discharge voltage to prevent overdischarge of its electrochemical cells 12, the battery stopped operating while a plurality of its electrochemical cells 12 were still within their voltage discharge operating window. Again, the battery effectively stopped operating with capacity remaining.

[0048] There emerges once again from the graph of Figure 10 that the electrochemical cells located close to the heat sinks provided by the upper and lower walls 34 and 36 and by the internal walls 62 and 63 reach their end of discharge voltage more rapidly than the electrochemical cells located farther away from those heat sinks. Since the discharge capacity of the electrochemical cells 12 is dependent upon the temperature of the electrochemical cells 12, it stands to reason that the electrochemical cells located close to the heat sinks have more difficulties remaining at their operating temperatures due to their proximity to heat sinks and therefore are colder and effectively have less capacity than the electrochemical cells located farther away from the heat sinks.

[0049] The same solution previously described applies to the embodiment of the battery of Figure 9 including three bundles 60 enclosed in a rigid casing 30 having two internal walls 62 and 63 to alleviate this problem. The inventors have devised new bundle assemblies in which the electrochemical cells close to the heat sinks are made with laminates 20 having increased discharge capability at lower temperature

and lower impedance or internal resistance by increasing the lithium salt concentration in the electrolyte 24 and cathode 26 of their laminates 20.

[0050] Specifically, the electrochemical cells Nos. 1, 2, 5 to 8, 11 to 14 and 17, 18 which are close to the heat sinks are configured to have a lower impedance than the electrochemical cells located farther away from the heat sinks by reducing the polymer/lithium salt ratio in the electrolytes 24 from 30:1 to 25:1 and reducing the polymer/lithium salt ratio in the cathodes 26 from 35:1 to 30:1 thereby effectively increasing discharge capability of electrochemical cells Nos. 1, 2, 5 to 8, 11 to 14 and 17, 18 at lower temperature and compensating for the heat loss experienced by those electrochemical cells.

[0051] The same solution to the problem of premature end of cycle of the electrochemical cells located adjacent to the heat sinks provided by the walls of the casing of a battery also applies to a battery having plurality of cylindrical electrochemical cells or a plurality of prismatic electrochemical cells.

[0052] With reference to Figures 11a and 11b, there is shown a battery 50 including an array of cylindrical electrochemical cells 52 inserted in a rigid casing 54. The electrochemical cells 52 closest or adjacent to the walls of the rigid casing 54 which act as heat sinks are subject to the same problem of reaching the end of their discharge voltage before the electrochemical cells 52 located away from the heat sinks reach their end of discharge voltage. Because the battery 50 reaches its end of discharge voltage when one of the electrochemical cells 52 reaches its end of discharge voltage, the battery 50 stopped operating while a plurality of its electrochemical cells 52 were still within their voltage discharge operating window. The battery 50 therefore stopped operating with capacity remaining.

[0053] With reference to Figure 12, cylindrical electrochemical cells 52 consists of a single laminate 20 rolled multiple times into a spiral, the length of the single laminate 20 defines the number of layers or turns in the spiral roll 56 which defines the capacity of the cylindrical electrochemical cell 52. Therefore, in order to lower the impedance or internal resistance of the cylindrical electrochemical cells 52 close to or adjacent to the walls of the rigid casing 54, it is possible to produce cylindrical electrochemical cells 52 with a laminate 20 made with an electrolyte 24

and a cathode 26 having an increased lithium salt concentration thereby producing a cylindrical electrochemical cells 52 having an increased discharge capability at lower temperature. As previously described, the laminate 20 would include an electrolyte 24 having a polymer/lithium salt ratio of 25:1 instead of 30:1 and a cathode 26 having a polymer/lithium salt ratio of 30:1 instead of 35:1 thereby effectively increasing discharge capability at lower temperature of the electrochemical cells adjacent to the heat sinks of the walls of the rigid casing 54 and compensating for the heat loss experienced by those electrochemical cells and solving the problem of reaching the end of their discharge voltage before the electrochemical cells 52 located away from the heat sinks reach their end of discharge voltage.

[0054] Similarly, a battery which includes a plurality of prismatic electrochemical cells inserted in a rigid casing will encounter the same problem wherein the prismatic electrochemical cells closest or adjacent to the walls of the rigid casing which act as heat sinks will reach the end of their discharge voltage before the electrochemical cells located away from the heat sinks reach their end of discharge voltage and therefore the battery will reach its end of discharge voltage when one of the electrochemical cells reaches its end of discharge voltage. The battery will stop operating while a plurality of its prismatic electrochemical cells is still within their voltage discharge operating window. The prismatic battery therefore stopped operating with capacity remaining.

[0055] As described with reference to cylindrical electrochemical cells 52, a prismatic electrochemical cell consists of a single laminate flat rolled multiple times into a flat spiral roll; the length of the single laminate defines the number of layers or turns in the flat spiral roll which defines the capacity of the prismatic electrochemical cell. Therefore, in order to lower the impedance or internal resistance of the prismatic electrochemical cells close to or adjacent to the walls of the rigid casing, it is possible to produce prismatic electrochemical cells with a laminate 20 made with an electrolyte 24 and a cathode 26 having an increased lithium salt concentration thereby producing a prismatic electrochemical cells having an increased discharge capability at lower temperature. As previously described, the laminate 20 would include an electrolyte 24 having a polymer/lithium salt ratio of 25:1 instead of 30:1 and a cathode 26 having a polymer/lithium salt ratio of 30:1 instead of 35:1 thereby

effectively increasing discharge capability at lower temperature of the electrochemical cells adjacent to the heat sinks and compensating for the heat loss experienced by those electrochemical cells and solving the problem of reaching the end of their discharge voltage before the other electrochemical cells located away from the heat sinks reach their end of discharge voltage.

[0056] The same problematic applies to batteries using cooling systems to maintain the temperature of their electrochemical cells below a predetermined temperature threshold. The electrochemical cells located closest to the path of the cooling fluid which acts as heat sinks will reach their end of their discharge voltage before the electrochemical cells located away from the heat sinks. As described with reference to the previous embodiments of the invention, the problem is solved by rearranging the electrochemical cells in the battery such that the electrochemical cells positioned adjacent to the heat sink path of the cooling system have a lower impedance by increasing the salt concentration in the electrolyte 24 and the cathode 26 of the laminates 20 constituting the electrochemical cells.

[0057] Modifications and improvements to the above-described embodiments of the present invention may become apparent to those skilled in the art. The foregoing description is intended to be exemplary rather than limiting. The scope of the present invention is therefore intended to be limited solely by the scope of the appended claims.

What is claimed is:

1. A lithium battery comprising:

a plurality of electrochemical cells assembled together which are inserted in a rigid casing having side walls and upper and lower walls forming an enclosure, the electrochemical cells including an anode, a cathode and an electrolyte; and

at least one heat sink path to dissipate excess heat generated by the electrochemical cells,

the electrochemical cells being assembled such that electrochemical cells positioned adjacent to the heat sink path have a lower impedance than other electrochemical cells of the battery,

the electrochemical cells positioned adjacent to the heat sink path including an electrolyte and a cathode having a higher lithium salt concentration than the other electrochemical cells of the battery.

2. A lithium battery as defined in claim 1, wherein the electrolyte and the cathode of the electrochemical cells positioned adjacent to the heat sink path each have a polymer/lithium salt ratio that is less than a polymer/lithium salt ratio of the other electrochemical cells by a value of 5:1.

3. A lithium battery as defined in claim 1, wherein the rigid casing further comprises an internal wall providing a further heat sink path and wherein the electrochemical cells positioned adjacent to the internal wall have a lower impedance than the other electrochemical cells of the battery.

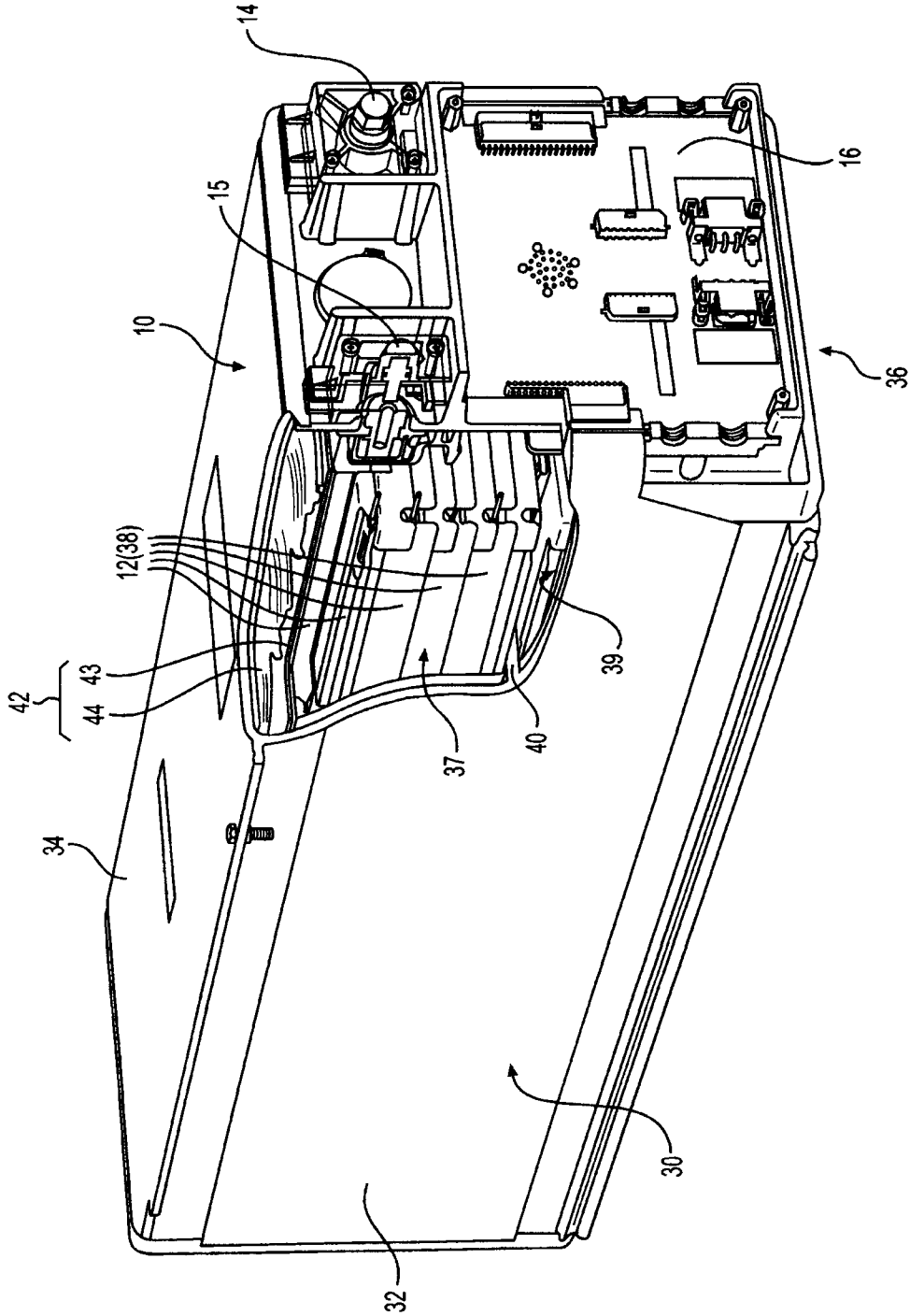
4. A lithium battery as defined in claim 3, wherein the electrolyte and the cathode of the electrochemical cells positioned adjacent to the heat sink path each have a polymer/lithium salt ratio that is less than a polymer/lithium salt ratio of the electrolyte and the cathode of the other electrochemical cells by a value of 5:1.

5. A lithium battery as defined in claim 1, wherein each electrochemical cell of the plurality of electrochemical cells consists of a multi-layer assembly of single laminates and multiple electrochemical cells of the plurality of electrochemical cells are stacked one against the other to form a bundle.

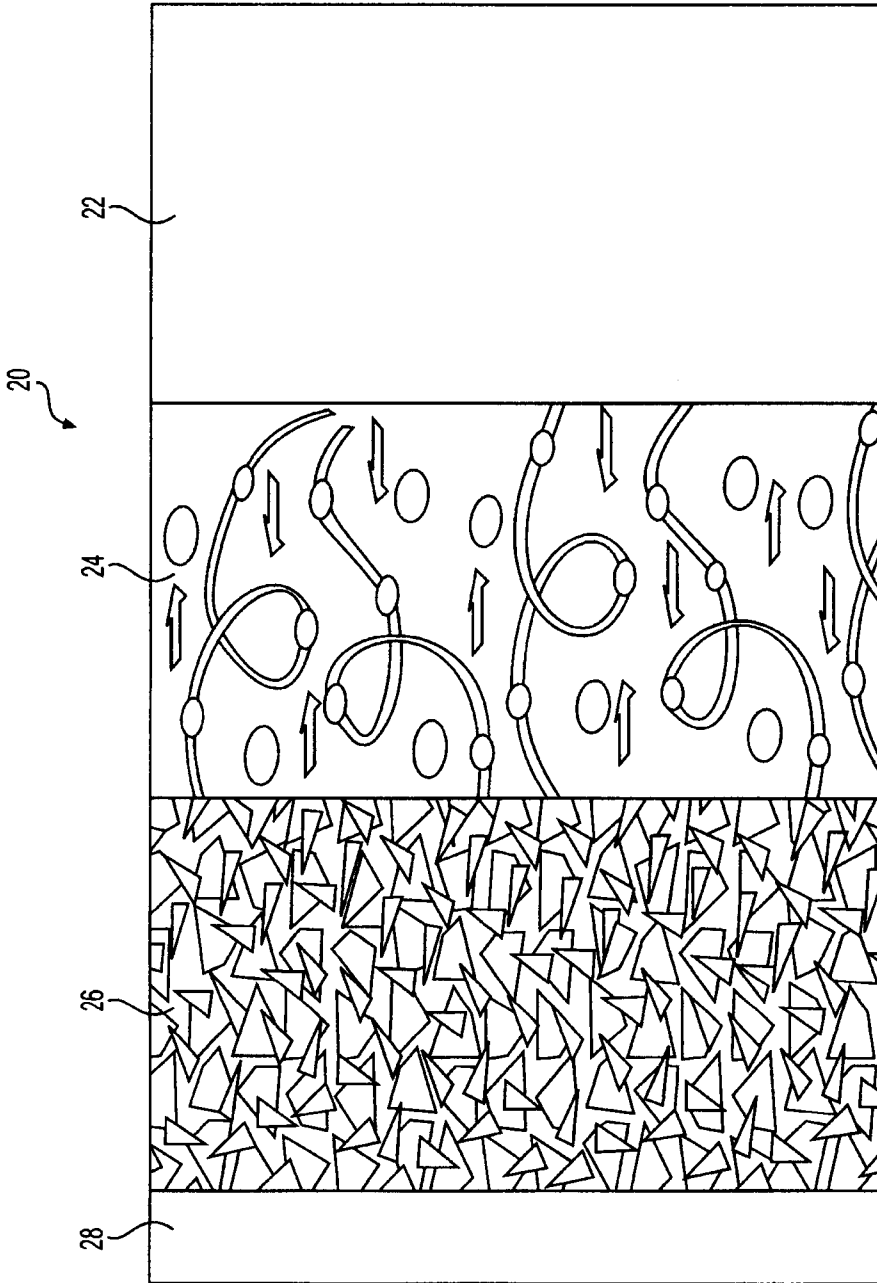
6. A lithium battery as defined in claim 1, wherein the electrochemical cells consists of a single laminate rolled multiple times into a spiral to form cylindrical electrochemical cells.

7. A lithium battery as defined in claim 1, wherein the at least one heat sink path is provided by the walls of the casing.

8. A lithium battery as defined in claim 1, further comprising a cooling system wherein the at least one heat sink path is provided by the cooling system.

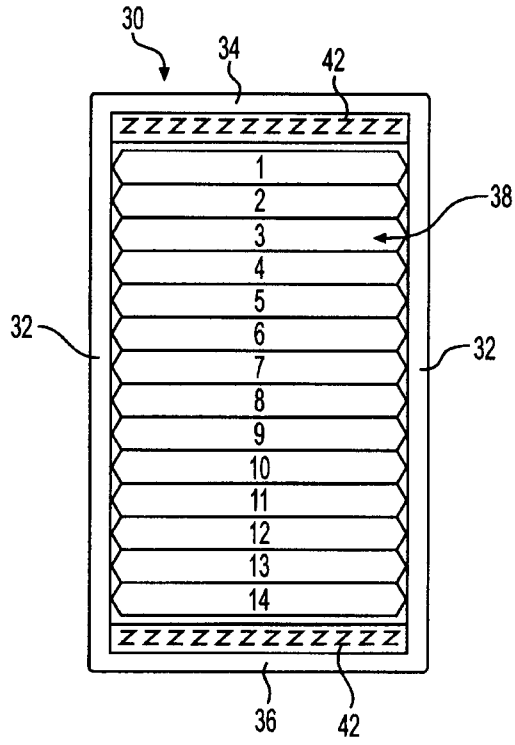


**FIG. 1**

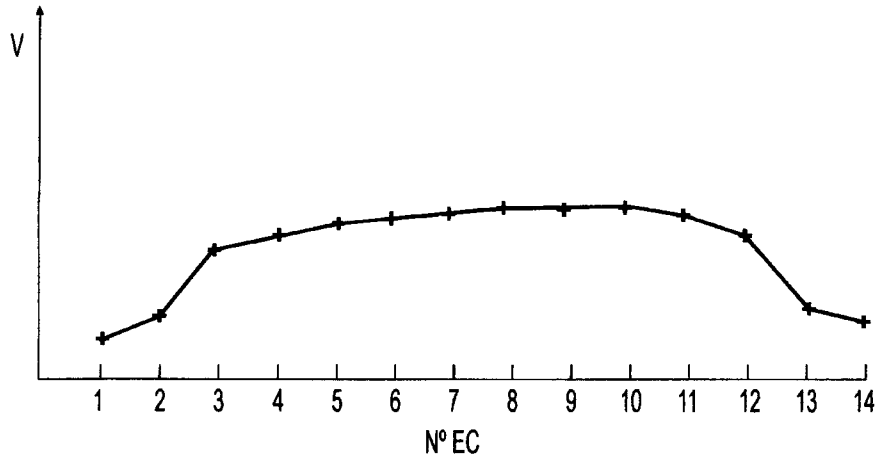


**FIG. 2**

3/7

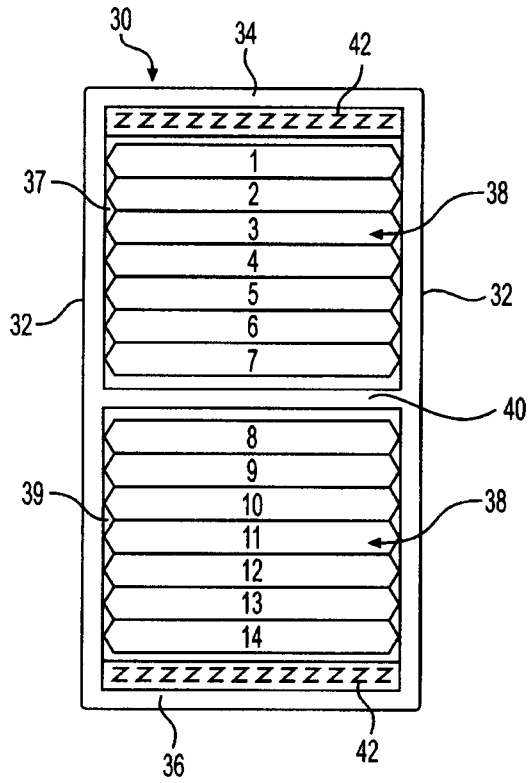


**FIG. 3**

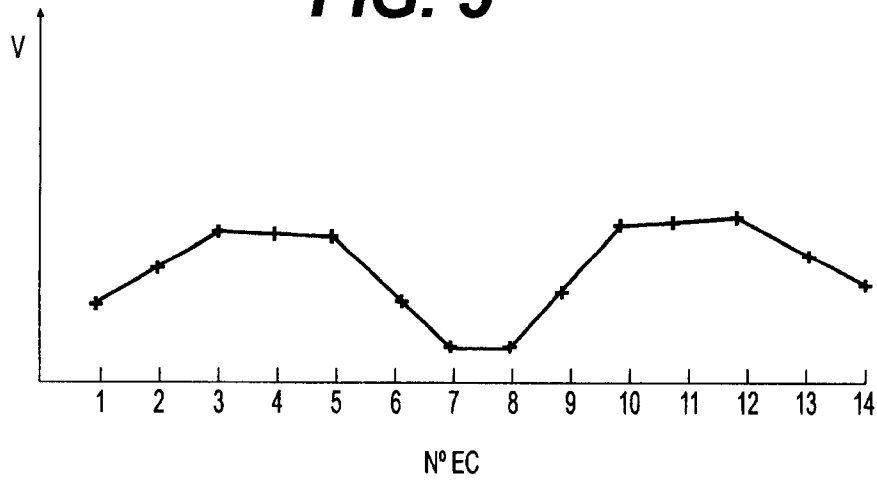


**FIG. 4**

4/7

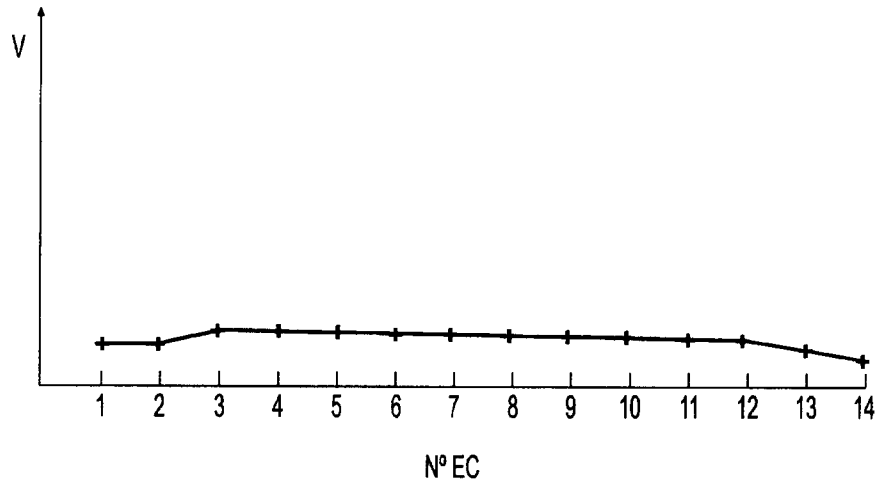


**FIG. 5**

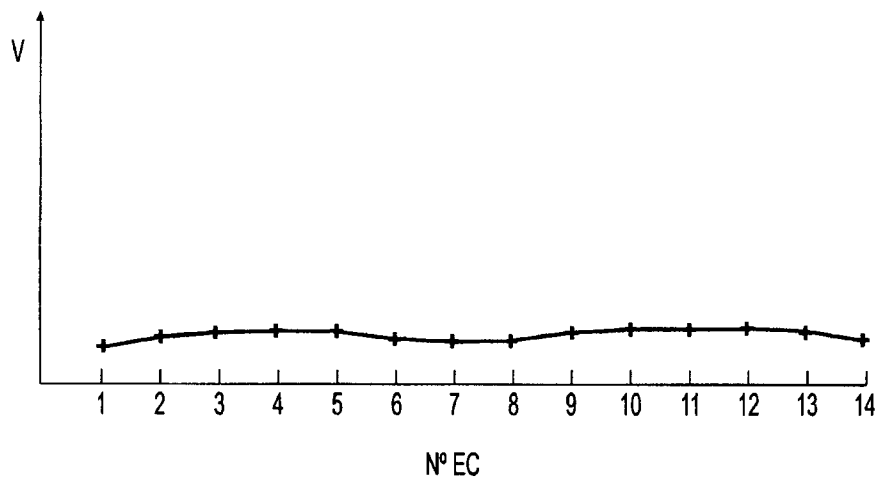


**FIG. 6**

5/7

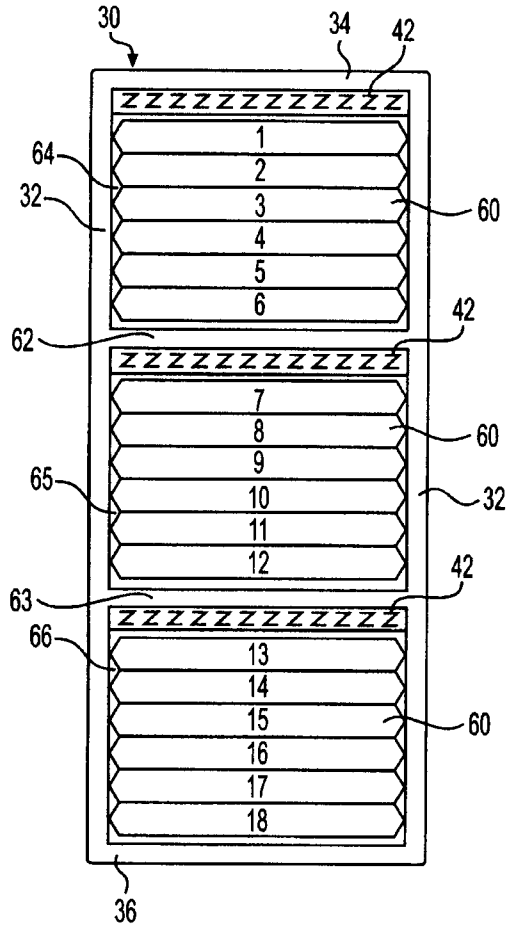


**FIG. 7**

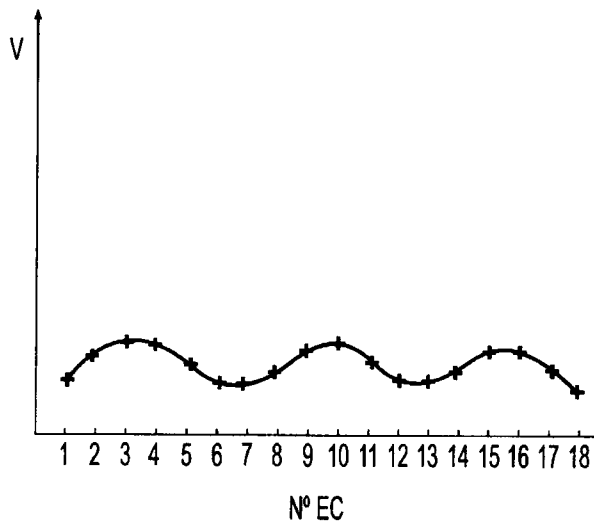


**FIG. 8**

6/7

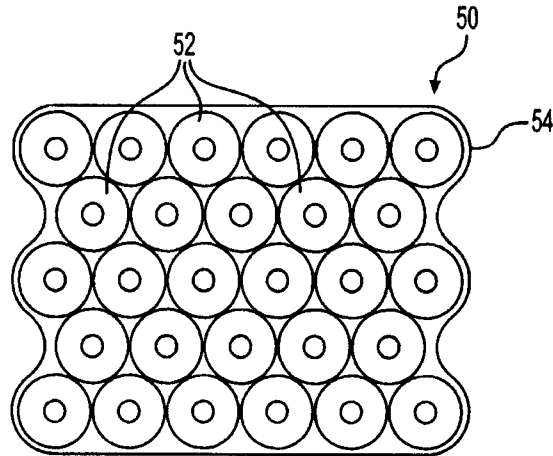


**FIG. 9**

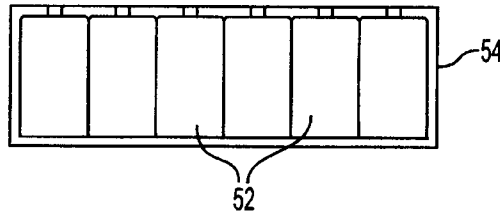


**FIG. 10**

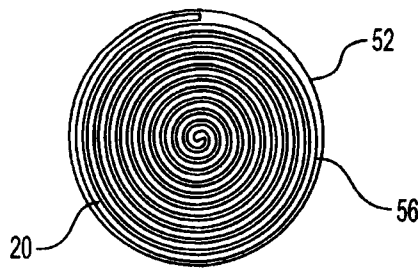
7/7



**FIG. 11A**



**FIG. 11B**



**FIG. 12**

