

W. MURRAY.

Machines for Making Plaited and Puffed Trimmings.

No. 134,216.

Patented Dec. 24, 1872.

Fig. 1.

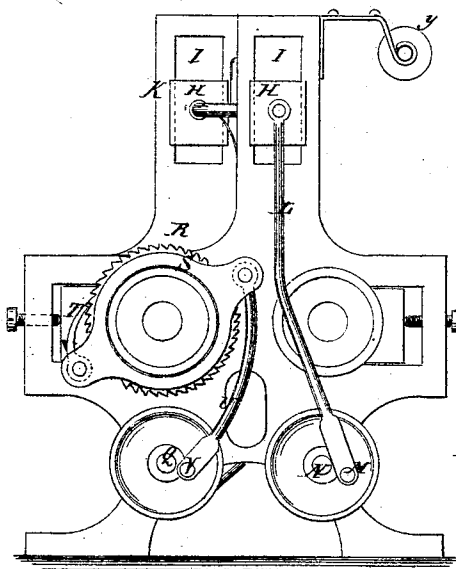

Fig. 2.

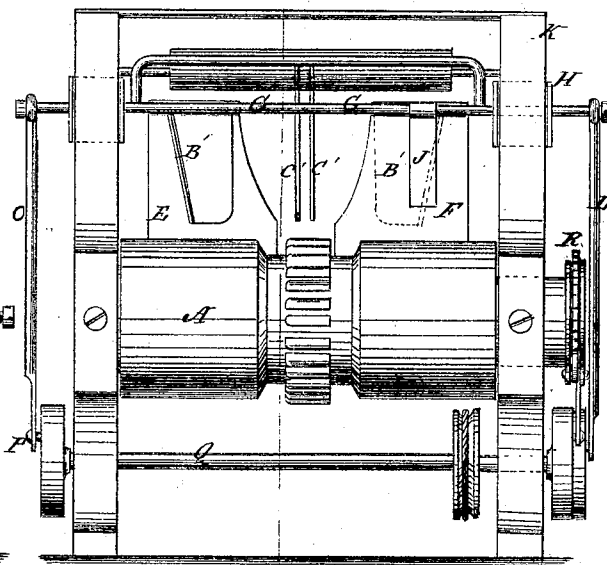

Fig. 3.

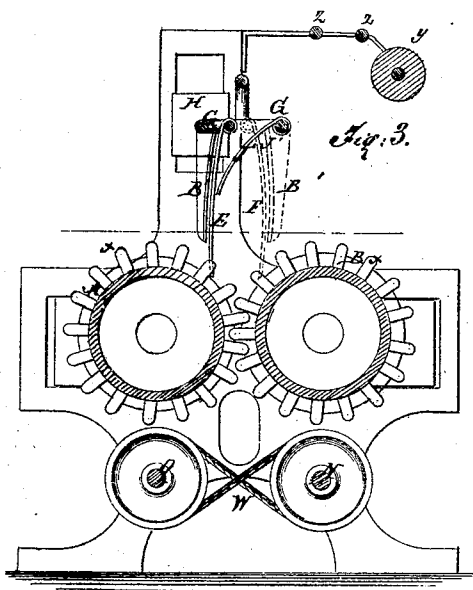

Fig. 4.

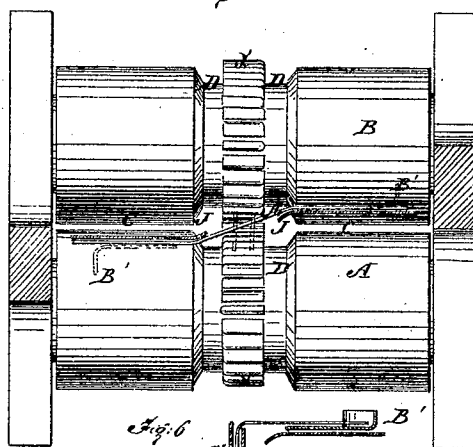

Fig. 6.

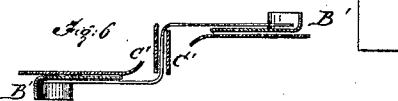
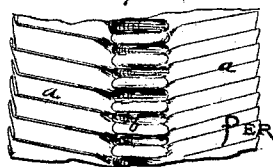

Fig. 5.



Witnesses:

Chas. Nida
C. Scudder

Inventor:

W. Murray
Munn & Co.
Attorneys.

UNITED STATES PATENT OFFICE.

WELWOOD MURRAY, OF NEW YORK, N. Y.

IMPROVEMENT IN MACHINES FOR MAKING PLAITED AND PUFFED TRIMMINGS.

Specification forming part of Letters Patent No. 134,216, dated December 24, 1872.

To all whom it may concern:

Be it known that I, WELWOOD MURRAY, of the city, county, and State of New York, have invented a new and Improved Machine for Making Plaited and Puffed Trimmings, of which the following is a specification:

My invention consists of a pair of intermittingly-rotating rollers, either with or without puffing teeth or cogs, combined with a pair of folding-blades or knives in such manner that a strip of cloth will be plaited on each border with a row of puffs between, the plaits of each side being reversed as to each other; or they may be turned the same way, if preferred, by a slight change of the blades, so as to operate against one roller only.

Figure 1 is an end elevation of my improved machine for making reverse plaited and puffed trimmings. Fig. 2 is a side elevation. Fig. 3 is a transverse sectional elevation. Fig. 4 is a top-plan view of the rolls.

Similar letters of reference indicate corresponding parts.

A and B represent a pair of rolls, arranged side by side a little distance apart, as indicated at C, with a deep wide groove, D, at the middle. E F represent the folding-blades, which consist of blades or plates of metal about as wide or a little wider than the large parts of the rolls. They are suspended from a frame, G, mounted on vertically-sliding blocks H in ways I, in the upper part of the housings K, so that one bears against the face of one roll upon one side of the groove D, and the other bears upon the face of the other roll on the other side of the groove, both coming down to the rolls between them, but not quite as low as the horizontal plane of the axes. They are bent on the edges fronting each other to coincide with a line drawn between them or nearly so, as shown at J, Fig. 4. A spring, J', is arranged with each blade to press it against the roll. The frame G is connected at one end by a rod, L, and crank-pin M, with a disk on a counter-shaft, N, under roll B. The other end is connected by a rod, O, and crank-pin P with a disk on a counter-shaft, Q, under roll A, by which a vertical reciprocating motion is imparted to the blades. The rolls are each provided with a ratchet-wheel, R, pawl-yoke S, and pawl T, and the pawl-yoke is connected to the counter-shaft, below the roll, by a rod,

U, crank-pin V, and a disk, so that an intermittent motion is imparted to them. The counter-shafts N and Q are geared together by pulleys and a belt, W, and they will be connected with the driving power in any approved way. The rolls are provided with puffing-teeth X, in the grooves D, to be used when large full puffs are to be made, but not when they are only required to be small; consequently they are detachably connected to the rolls. Y is a cloth-guide roller, and Z are guide-rods at the top of the housings, over which the cloth A' is to be drawn or fed into the machine, going between the blades and their respective rollers, as shown in Fig. 4. The blades have a much wider range of movement than the rolls, and they move downward to some extent before the rolls begin to move, first rising, however, while the rolls are standing still, the cloth being held by the rolls so that the blades do not draw it back. The blades impinge upon the cloth and the rolls, so that as they move down again they carry the cloth and make the folds for the plaits, the said folds being doubled between the blades and the rolls opposite to those against which they bear—that is, in the spaces C. When the folds have been thus made, the rolls are set in motion and move along with the blades, carrying the folds or plaits down between the rolls, where they come so close together that they hold the cloth against going back with the blades, which return for making the next folds while the rolls stop till they come down again, when they move forward again and draw the cloth the length of the plaits. The middle portion of the cloth between the plaits assumes the form of puffs, which will be large or small according to the breadth of the plaits. If they are small, they will be sufficiently regular and defined, as to shape, without the intervention of controlling devices; but if large, I prefer to employ the puffing-teeth X, which will corrugate or flute the puffed part in regular and well-defined shape.

If I wish to make puffs larger in proportion to the width of the plaits than will naturally come of the plaiting of the borders, I will use a guide, B', for the cloth, with converging sides, which will also puff it at the middle in the lengthwise direction to some extent before it comes to the puffing-teeth; but this puff will

be merged in the transverse puffs by the teeth. In order to prevent this preparatory puff from being developed along the plaits, it will be drawn over one or more guides, C', arranged between the blades to take up and hold the slack due to the contraction of the breadth of the cloth, until it is acted on and finally developed in transverse puffs by the teeth X. If I wish to arrange both rows of plaits in the same direction, I will adjust both plaiting-blades against one and the same roll.

In Fig. 5, *a* represents the plaits, which it will be seen are reverse to each other, and *b* represents the puffs. To vary the breadth of the puffs, the movements of the blades will be varied, which may be done by shifting the crank-pins M relatively to the axes of the disks, for which I will, in a practical machine, have them properly arranged. I will also vary the motion of the rolls correspondingly, if desired. The object of bending the inner edges of the plaiting-blades, as shown at J, is to have them correspond to some extent with the angle of the cloth between the blades, which gives better results, in respect of the symmetry of the work, than would otherwise be obtained. The rolls will be made hollow, and provided with

any suitable heating apparatus for keeping them hot.

To widen or narrow the grooves of the rolls for varying the length of the puffs, the large parts of the rolls may be made adjustable in the smaller part toward and from each other by any suitable arrangement.

Having thus described my invention, I claim as new and desire to secure by Letters Patent—

1. The combination of a pair of reciprocating plaiting-blades and a pair of intermittingly-rotating rolls, substantially as specified.

2. The combination of the puffing-teeth with the rolls, substantially as specified.

3. The plaiting-blades, having the inner edges J bent to the angle of the cloth or thereabout, substantially as specified.

4. The combination, with a plaiting and puffing machine, of a gage, B', for contracting the goods to increase the fullness of the puffs, substantially as specified.

WELWOOD MURRAY.

Witnesses:

A. P. THAYER,
C. SEDGWICK.