

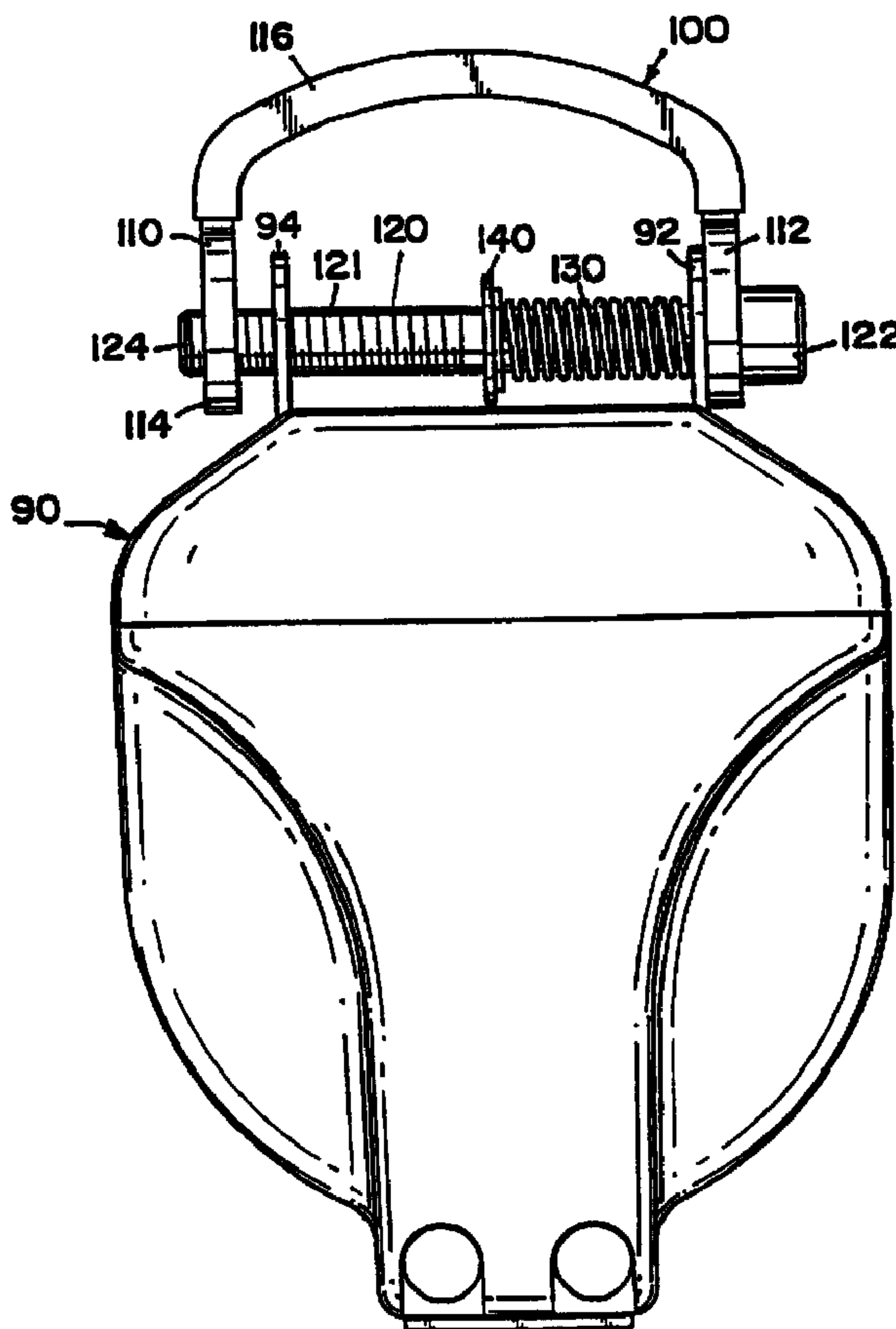

(86) Date de dépôt PCT/PCT Filing Date: 1999/10/21
 (87) Date publication PCT/PCT Publication Date: 2000/05/04
 (45) Date de délivrance/Issue Date: 2008/04/22
 (85) Entrée phase nationale/National Entry: 2001/03/29
 (86) N° demande PCT/PCT Application No.: US 1999/024643
 (87) N° publication PCT/PCT Publication No.: 2000/024304
 (30) Priorité/Priority: 1998/10/23 (US09/177,403)

(51) Cl.Int./Int.Cl. *A62B 37/00* (2006.01),
A47L 3/04 (2006.01), *A62B 35/04* (2006.01),
E04G 21/32 (2006.01)
 (72) Inventeurs/Inventors:
 WOLNER, JAMES T., US;
 CASEBOLT, SCOTT C., US
 (73) Propriétaire/Owner:
 D B INDUSTRIES, INC., US
 (74) Agent: CASSAN MACLEAN

(54) Titre : CONNECTEUR POUR DISPOSITIF DE SECURITE PERSONNELLE
 (54) Title: CONNECTOR FOR A PERSONAL SAFETY DEVICE



(57) Abrégé/Abstract:

A connector (100) and a personal safety device (90) are secured in series between a person and a support structure (80). The connector (100) includes a bolt (120) and another structural member (110) which cooperate to form a closed loop. The bolt (120)

(57) **Abrégé(suite)/Abstract(continued):**

extends through opposite ends (112, 114) of the other structural member (110) at least one flange (92, 94) on the personal safety device (90). A radially extending flange (140) is rigidly secured to an intermediate portion of the bolt (120) and cooperates with an end of the bolt (120) to capture an end of the other structural member (110) therebetween.



PCT

WORLD INTELLECTUAL PROPERTY ORGANIZATION
International Bureau

INTERNATIONAL APPLICATION PUBLISHED UNDER THE PATENT COOPERATION TREATY (PCT)

(51) International Patent Classification ⁶ : A47L 3/04	A1	(11) International Publication Number: WO 00/24304 (43) International Publication Date: 4 May 2000 (04.05.00)
<p>(21) International Application Number: PCT/US99/24643</p> <p>(22) International Filing Date: 21 October 1999 (21.10.99)</p> <p>(30) Priority Data: 09/177,403 23 October 1998 (23.10.98) US</p> <p>(71) Applicant (for all designated States except US): D B INDUSTRIES, INC. [US/US]; 3965 Pepin Avenue, Red Wing, MN 55066 (US).</p> <p>(72) Inventors; and (75) Inventors/Applicants (for US only): WOLNER, James, T. [US/US]; 1504 Norwood, Red Wing, MN 55066 (US). CASEBOLT, Scott, C. [US/US]; 1460 Laurel Avenue, St. Paul Park, MN 55071 (US).</p> <p>(74) Agent: MAU, Michael, L.; Mau & Krull, P.A., Suite E, 1250 Moore Lake Drive East, Fridley, MN 55432 (US).</p>	<p>(81) Designated States: AL, AM, AT, AU, AZ, BA, BB, BG, BR, BY, CA, CH, CN, CU, CZ, DE, DK, EE, ES, FI, GB, GE, GH, GM, HU, ID, IL, IS, JP, KE, KG, KP, KR, KZ, LC, LK, LR, LS, LT, LU, LV, MD, MG, MK, MN, MW, MX, NO, NZ, PL, PT, RO, RU, SD, SE, SG, SI, SK, SL, TJ, TM, TR, TT, UA, UG, US, UZ, VN, YU, ZW, ARIPO patent (GH, GM, KE, LS, MW, SD, SL, SZ, TZ, UG, ZW), Eurasian patent (AM, AZ, BY, KG, KZ, MD, RU, TJ, TM), European patent (AT, BE, CH, CY, DE, DK, ES, FI, FR, GB, GR, IE, IT, LU, MC, NL, PT, SE), OAPI patent (BF, BJ, CF, CG, CI, CM, GA, GN, GW, ML, MR, NE, SN, TD, TG).</p> <p>Published With international search report.</p>	

(54) Title: CONNECTOR FOR A PERSONAL SAFETY DEVICE

(57) Abstract

A connector (100) and a personal safety device (90) are secured in series between a person and a support structure (80). The connector (100) includes a bolt (120) and another structural member (110) which cooperate to form a closed loop. The bolt (120) extends through opposite ends (112, 114) of the other structural member (110) at least one flange (92, 94) on the personal safety device (90). A radially extending flange (140) is rigidly secured to an intermediate portion of the bolt (120) and cooperates with an end of the bolt (120) to capture an end of the other structural member (110) therebetween.

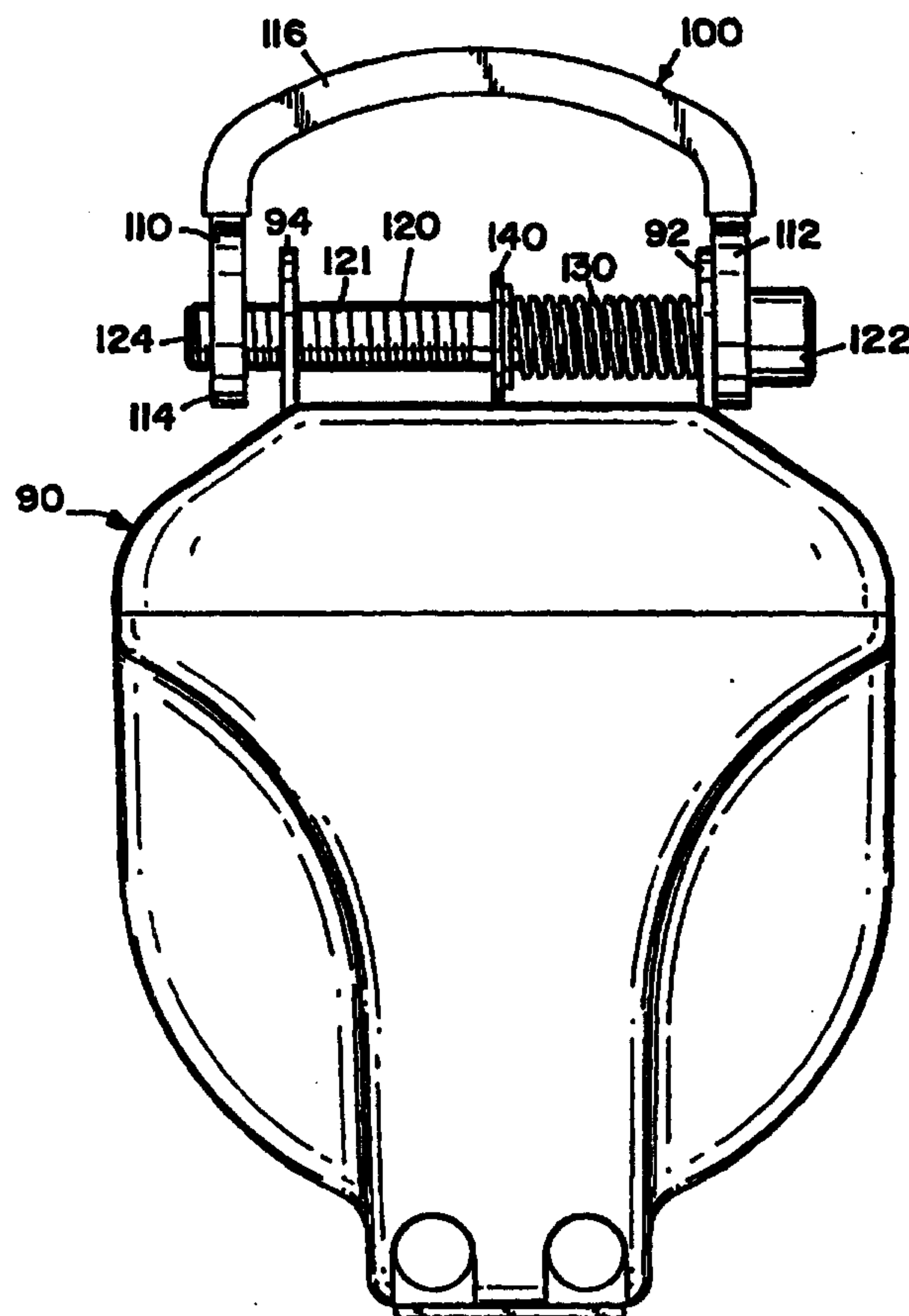

CONNECTOR FOR A PERSONAL SAFETY DEVICE

Background of the Invention

5 Field of the Invention

The present invention relates to methods and apparatus for interconnecting a personal safety device in series between a person and a support structure.

Background of the Invention

10 Various occupations place people in precarious positions at relatively dangerous heights, thereby creating a need for fall-arresting safety apparatus. Such apparatus require a reliable safety line and reliable connections to the support structure and the person working in proximity to the support structure.

Typically, one or more deceleration devices is connected in series with the safety line. For example, U.S. Pat. No. 5,351,906 to Feathers discloses a safety anchorage
15 device which controls pay-out of a safety line. This prior art anchorage device is selectively connected to a support structure, and the safety line is selectively connected to a person (via a body harness, for example). In the event of a fall, the safety line and the other parts of the anchorage device cooperate to safely bring the person to rest.

Another exemplary safety device is disclosed in U.S. Pat. No. 4,877,110 to
20 Wolner. This prior art safety device similarly controls pay-out of a safety line during normal work activity and/or in the event of a fall. In this patent, however, the device is shown anchored to the body harness, and the safety line is shown connected to the support structure.

An object of the present invention is to provide an improved connector for use on
25 and/or together with safety devices like those discussed above.

Summary of the Invention

In accordance with an embodiment of the present invention, a connector in combination with a personal safety device having a first flange and a second flange is provided, which includes: a structural member having a first end and a second end; a bolt

having a shaft; a head connected to a first end of the shaft, where the head is larger in diameter than the shaft; and a shoulder connected to an intermediate portion of the shaft, where the shoulder is larger in diameter than the shaft, and the first flange is disposed on the shaft and captured between the head and the shoulder, and a second, opposite end of the shaft is selectively connected to the second flange where said first end of the structural member is disposed on the shaft and the second end of the shaft is selectively connected to the second end of the structural member.

Preferably the first end of the structural member is captured between the head and the shoulder and an opening is provided in the second end of the structural member to selectively receive the second, opposite end of the shaft. The second, opposite end of the shaft may be provided with external threads, and the opening may be provided with mating internal threads. A helical coil spring may be disposed on the shaft between the shoulder and the first end of the structural member. The structural member may be generally U-shaped. The first flange is preferably secured to the shaft between the shoulder and the first end of the structural member and the second flange is preferably selectively secured to the shaft between the shoulder and the second end of the structural member.

In another embodiment of the present invention, a personal safety device is provided, which includes: a base; a reel rotatably mounted on the base; a line wound about the reel and having an accessible end; a structural member having a first end and a second end; and a bolt having a shaft, a head connected to a first end of the shaft, where the head is larger in diameter than the shaft, and a shoulder connected to an intermediate portion of the shaft, where the shoulder is larger in diameter than the shaft, where a first flange on the base is mounted on the shaft and captured between the head and the shoulder, and a second, opposite end of the shaft is selectively connected to a second flange on the base where the first end of the structural member is mounted on the shaft and the second end of the shaft is selectively connected to the second end of the structural member.

In another embodiment of the present invention, a connector in combination with a personal safety device is provided, which includes: a bolt having a shaft which extends from a first end to a second end, a head mounted on the first end, and a shoulder mounted on the shaft between the first end and the second end, where both the head and the shoulder are

larger in diameter than the shaft, and a flange on the safety device is disposed on the shaft and captured between the head and the shoulder; and a structural member which cooperates with the shaft to selectively form a closed loop, where a first portion of the structural member is disposed on the shaft and captured between the head and the shoulder, and a second
5 portion of the structural member is selectively connected to the shaft proximate the second end thereof.

Additional features and/or advantages of the present invention may become more apparent from the detailed description which follows.

Brief Description of the Drawing

With reference to the Figures of the Drawing, wherein like numerals represent
10 like parts and assemblies throughout the several views,

Figure 1 is a front view of a personal safety apparatus provided with a connector constructed according to the principles of the present invention;

Figure 2 is a side view of the personal safety apparatus and connector of Figure 1;
and

15 Figure 3 is a perspective view of the personal safety apparatus and connector of Figure 1 interconnected in series between a support structure and a body harness.

Detailed Description of the Preferred Embodiment

A preferred embodiment connector constructed according to the principles of the present invention is designated as 100 in Figures 1-3. The connector 100 includes a
20 structural member 110 and a bolt 120 which cooperate to releasably connect a personal safety device 90 (with safety line 98) in series between a support structure 80 and a person's harness 70, as shown in Figure 3. Exemplary prior art safety devices are disclosed in U.S. Pat. No. 5,351,906 to Feathers and U.S. Pat. No. 4,877,110 to Wolner.

25 The structural member 110 is preferably made of steel and may be described as a U-shaped member having an intermediate base portion, and opposite ends or legs 112 and

114 which extend from opposite ends of the base portion and parallel to one another. The base portion is covered by a protective sleeve 116 which is preferably made of plastic. A slot 118 is provided in the first end 112 of the member 110 (Figure 2), and a threaded hole is provided in the second end 114 of the member 110.

5 The bolt 120 is preferably made of steel and has a shaft 121 which extends perpendicular to the ends 112 and 114 of the member 110. A first end 122 of the bolt 120 is provided with a head having a diameter which is greater than the diameter of the shaft 121. A second, opposite end 124 of the bolt 120 is provided with external helical threads which mate with the threaded hole in the second end 114 of the member 110.

10 The second end 124 of the bolt 120 is inserted through the slot 118, then through a hole in a first flange or tab 92 on the device 90, and then through a helical coil spring 130. A stop 140 is then rigidly secured to an intermediate portion of the shaft 121 on the bolt 120, in such a manner that the spring 130 is compressed between the stop 140 and the flange 92. The stop 140 has a relatively larger diameter than the shaft 121 of the bolt
15 120 and may be described as a shoulder on the bolt 120. The second end 124 may then be selectively inserted through a hole in a second flange or tab 94 on the device 90, and threaded through the hole in the second end 114 of the member 110.

 The threads on the second end 124 of the bolt 120 and inside the hole in the second end 114 of the member 110 provide a means for selectively connecting the second
20 end 124 of the bolt 120 to the second end 114 of the member 110. The spring 130 cooperates with the stop 140 to provide a means for biasing the second end 124 of the bolt 120 to remain connected to the second end 114 of the member 110. The stop 140, the first end 112 of the member 110, and the head of the bolt 120 cooperate to provide a means for securing the connector 100 to the first flange 92. The slot 118 in the first end
25 112 of the member 110 provides a means for pivoting the connector 100 relative to the first flange 92 when the second end 122 of the bolt is free of the second flange 94.

 Those skilled in the art will recognize that alternative arrangements may be used to perform one or more of the aforementioned functions. For example, the first end 112 of the member 110 may be hinged relative to the remainder thereof to facilitate pivoting

of the connector 100 relative to the first flange 92. Also, the bias of the spring 130 may operate (in the absence of threads) to facilitate connection of the second end 124 of the bolt 120 to the second end 114 of the member 110. On one alternative embodiment, for example, the second end 124 of the bolt 120 is devoid of threads and has an outside
5 diameter which is less than the inside diameter of the threaded hole. Thus, even when the shaft 121 is not threaded into the threaded hole, the spring 130 biases the second end 124 to remain in the hole. Another option is to use a cotter pin or other latching device to further discourage undesired removal of the bolt end 124 from the member end 114.

Those skilled in the art will also recognize that the connector 100 may be used at
10 various locations in various personal safety systems. For example, Figure 3 shows the connector 100 attached to the personal safety device 90 and releasably connected to a harness 70 in the same manner as and/or by means of a D-ring, for example. A safety line 98 (or 98') emanates from the device 90 and is releasably connected to a support structure 80. This arrangement is advantageous because it facilitates convenient locking
15 into and out of discrete anchorages (81 and 82, for example) on the support structure. However, the connector 100 may be used in other arrangements according to the needs dictated by a particular situation and/or the preferences of the persons involved.

Another aspect of the present invention is the provision of a built-in connector or latching device on a personal safety device. In other words, a safety device constructed
20 according to the principles of the present invention may be connected directly about a rod or safety line secured to a support structure, thereby eliminating the need for an interconnecting snap hook or other discrete component. In this regard, the connection between the stop 140 and the bolt 120 is intended to be permanent, and thus, the present invention may be seen to provide both the safety device and the connecting means as a
25 unit.

Those skilled in the art will further recognize that the present invention may also be described in terms of a method (with reference to the preferred embodiment 100, for example). In one regard, the present invention may be described in terms of a method of connecting a personal safety device in series between a person and a support structure. A

bolt is inserted through a first end of a U-shaped member and through a first flange on the personal safety device. A coil spring is positioned on the bolt and retained in place by rigidly mounting a stop on an intermediate portion of the bolt. A second end of the U-shaped member is disposed about a suitable anchorage and/or inserted through a desired opening (such as a bracket on the support structure or a D-ring on a body harness), and then is aligned with a second flange on the personal safety device. A distal end of the bolt is then inserted through the second flange and threaded into the second end of the U-shaped member.

It should be noted that the first flange may be secured to the shaft between the shoulder and the first end of the structural member. Furthermore, the second flange may be selectively secured to the shaft between the shoulder and the second end of the structural member. The personal safety device may include, a base, a reel rotatably mounted on the base, and a line wound about the reel, with the line having an accessible end.

Although the present invention has been described with reference to a preferred embodiment and a particular application, this disclosure will enable those skilled in the art to recognize additional embodiments and/or applications which fall within the scope of the present invention. Accordingly, the scope of the present invention should be limited only to the extent of the following claims.

WHAT IS CLAIMED IS:

1. A connector in combination with a personal safety device having a first flange and a second flange, comprising:

5 a structural member having a first end and a second end;

a bolt having a shaft; a head connected to a first end of the shaft, wherein the head is larger in diameter than the shaft; and a shoulder connected to an intermediate portion of the shaft, wherein the shoulder is larger in diameter than the shaft, and the first flange is disposed on the shaft and captured between the head and the shoulder, and a
10 second, opposite end of the shaft is selectively connected to the second flange

wherein said first end of the structural member is disposed on the shaft and the second end of the shaft is selectively connected to the second end of the structural member.

2. The connector of claim 1, wherein the first end of the structural member is
15 captured between the head and the shoulder.

3. The connector of claim 2, wherein an opening is provided in the second end of the structural member to selectively receive the second, opposite end of the shaft.

20 4. The connector of claim 3, wherein the second, opposite end of the shaft is provided with external threads, and the opening is provided with mating internal threads.

5. The connector of claim 4, further comprising a helical coil spring disposed on the shaft between the shoulder and the first end of the structural member.

25

6. The connector of claim 5, wherein the structural member is generally U-shaped.

7. The connector of claim 2, further comprising a helical coil spring disposed on the shaft between the shoulder and the first end of the structural member.

5 8. The connector of claim 2, wherein the structural member is generally U-shaped.

9. The connector of claim 2, wherein the first flange is secured to the shaft between the shoulder and the first end of the structural member.

10 10. The connector of claim 9, further comprising a helical coil spring disposed on the shaft between the shoulder and the first flange.

11. The connector of claim 2, wherein the second flange is selectively secured to the shaft between the shoulder and the second end of the structural member.

15 12. A personal safety device, comprising:

a base;

a reel rotatably mounted on the base;

a line wound about the reel and having an accessible end;

20 a structural member having a first end and a second end; and

a bolt having a shaft, a head connected to a first end of the shaft, wherein the head is larger in diameter than the shaft, and a shoulder connected to an intermediate portion of the shaft, wherein the shoulder is larger in diameter than the shaft, wherein a first flange on the base is mounted on the shaft and captured between the head and the shoulder, and a second, opposite end of the shaft is selectively connected to a second flange on the base

25 wherein the first end of the structural member is mounted on the shaft and the second end of the shaft is selectively connected to the second end of the structural member.

13. The personal safety device of claim 12, wherein the first end of the structural member is captured between the head and the shoulder.

5 14. The personal safety device of claim 13, wherein the second flange is selectively mounted on the shaft and captured between the shoulder and the second end of the structural member.

10 15. The personal safety device of claim 13, further comprising a helical coil spring disposed on the shaft and compressed between the shoulder and the first flange.

16. The personal safety device of claim 13, wherein the structural member is generally U-shaped.

15 17. The personal safety device of claim 11, wherein an opening is provided in the second end of the structural member to selectively receive the second, opposite end of the shaft.

20 18. The personal safety device of claim 17, wherein the second, opposite end of the shaft is provided with external threads, and the opening is provided with mating internal threads.

25 19. The personal safety device of claim 18, further comprising a helical coil spring disposed on the shaft and compressed between the shoulder and the first flange.

20. A connector in combination with a personal safety device, comprising:
a bolt having a shaft which extends from a first end to a second end, a head mounted on the first end, and a shoulder mounted on the shaft between the first end and the second end, wherein both the head and the shoulder are larger in diameter than the shaft,

and a flange on the safety device is disposed on the shaft and captured between the head and the shoulder; and

5 a structural member which cooperates with the shaft to selectively form a closed loop, wherein a first portion of the structural member is disposed on the shaft and captured between the head and the shoulder, and a second portion of the structural member is selectively connected to the shaft proximate the second end thereof.

21. The connector of claim 20, wherein the second portion of the structural member is sized and configured to receive the second end of the shaft.

10 22. The connector of claim 20, further comprising a means for biasing the second portion of the structural member to remain connected to the second end of the shaft.

15 23. The connector of claim 22, wherein the means includes a helical coil spring compressed between the shoulder on the bolt and the flange on the safety device.

Cassan Maclean
307 Gilmour Street
Ottawa, ON K2P 0P7
Canada

Agents for the Applicant

FIG. 1

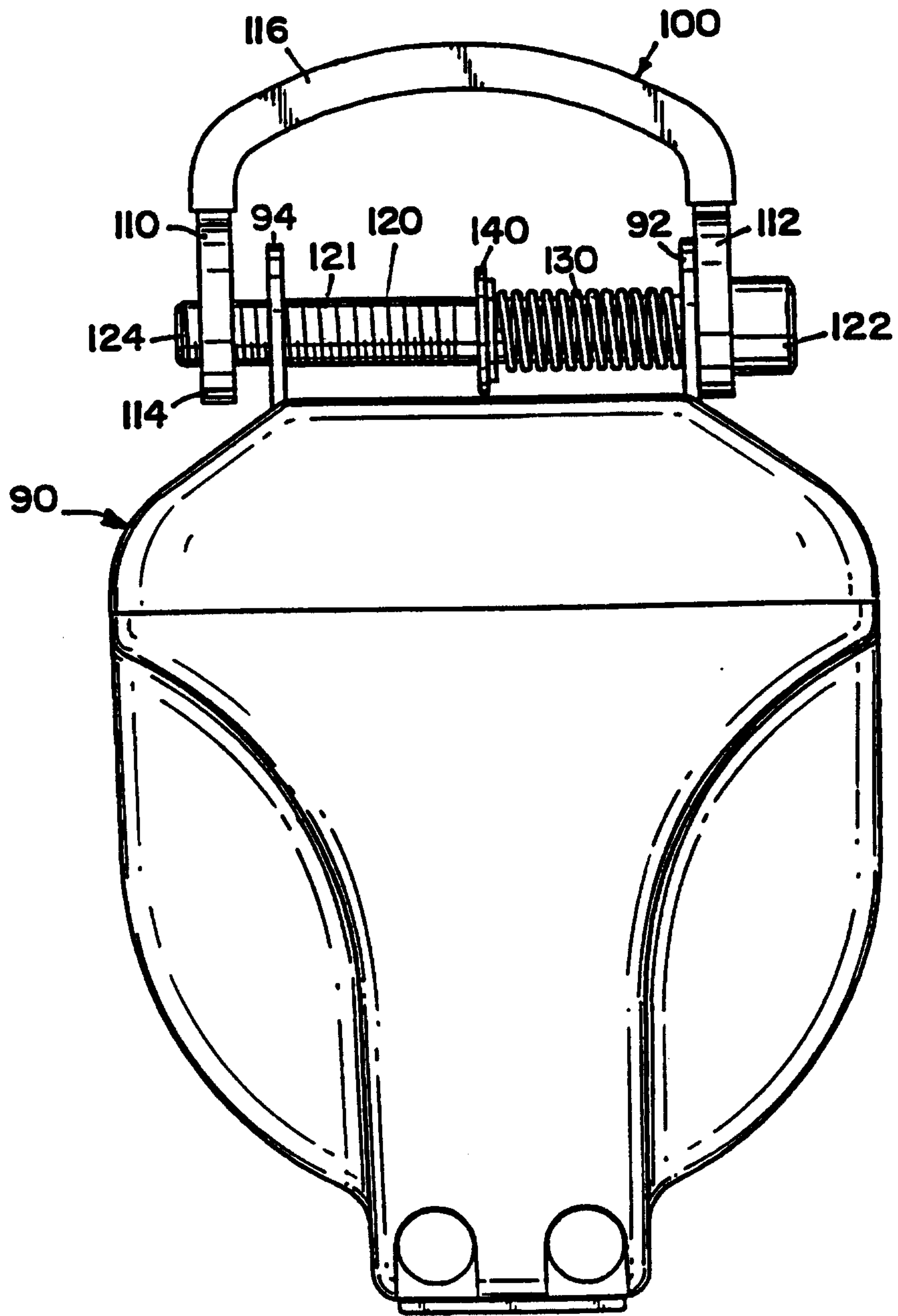

FIG. 2

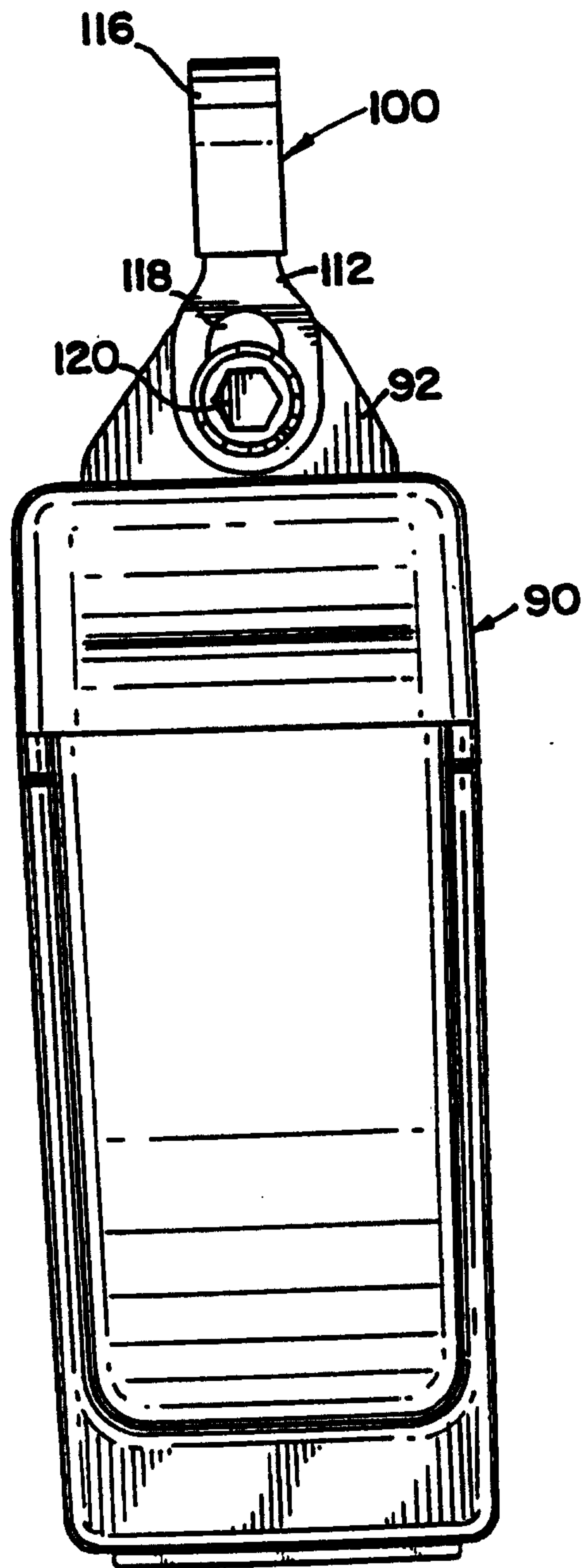

FIG. 3

