

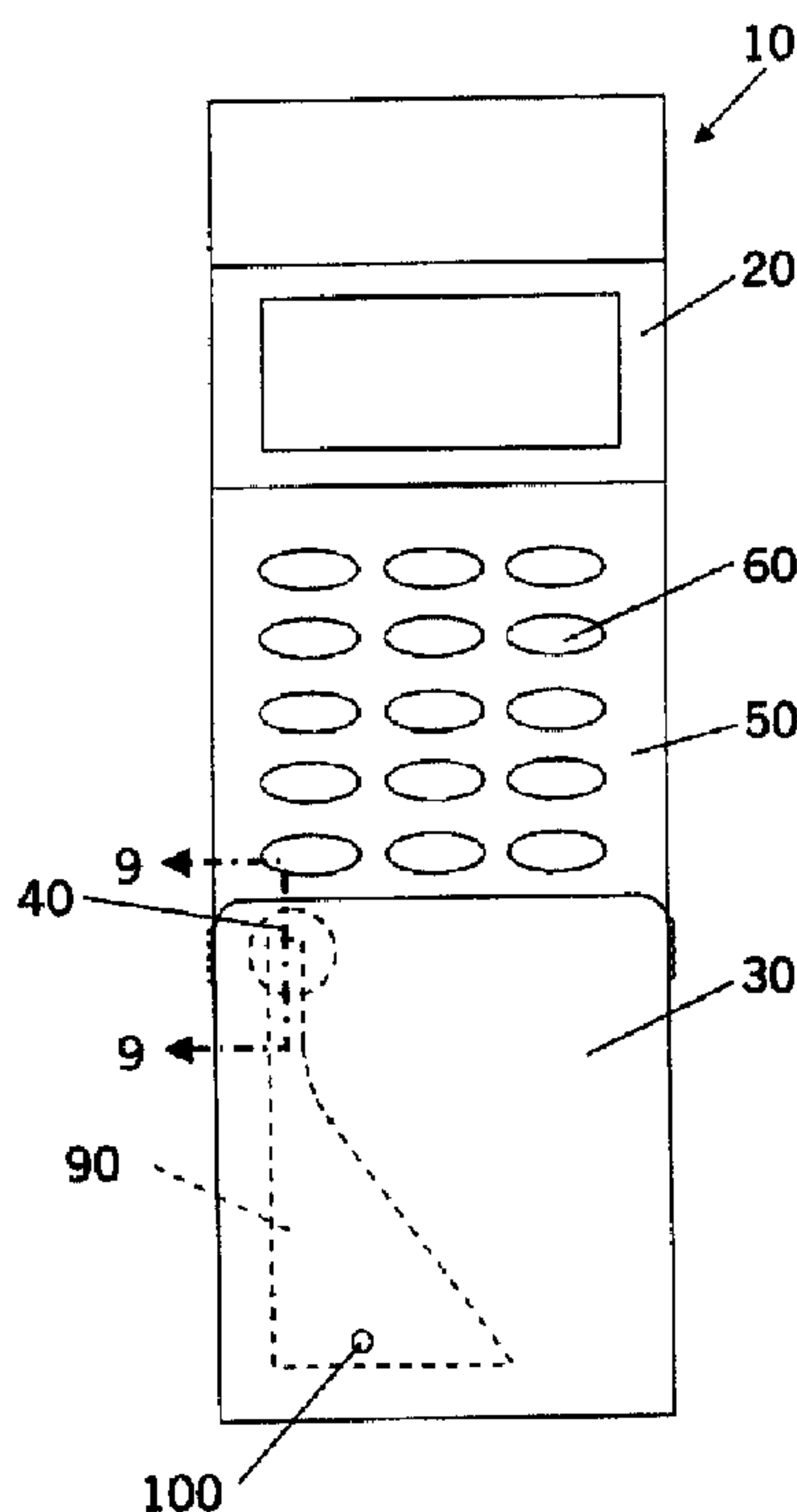

(86) Date de dépôt PCT/PCT Filing Date: 1998/09/01
 (87) Date publication PCT/PCT Publication Date: 1999/03/11
 (45) Date de délivrance/Issue Date: 2006/08/29
 (85) Entrée phase nationale/National Entry: 2000/02/01
 (86) N° demande PCT/PCT Application No.: US 1998/018146
 (87) N° publication PCT/PCT Publication No.: 1999/012322
 (30) Priorité/Priority: 1997/09/04 (US08/923,165)

(51) Cl.Int./Int.Cl. *H04M 1/02* (2006.01),
H04M 1/03 (2006.01)
 (72) Inventeurs/Inventors:
BARTHA, ISTVAN, SE;
THORNTON, CURTIS W., US
 (73) Propriétaire/Owner:
ERICSSON, INC., US
 (74) Agent: MARKS & CLERK

(54) Titre : **RADIOTELEPHONE AVEC DISPOSITIF ACOUSTIQUE COULISSANT**
 (54) Title: **RADIOTELEPHONE WITH SLIDING ACOUSTIC MEMBER**



(57) **Abrégé/Abstract:**

A radiotelephone having a slidably retractable member with an acoustic duct for transmitting sound through the member into a microphone housed in the radiotelephone's main body. The member is slidable to an extended position for use such that a sound inlet of the acoustic duct is exposed for collecting sound as a person speaks into it. Sound travels through the acoustic duct and passes directly through a sound outlet into the microphone. A sealing member adjacent the microphone acoustically seals the sound outlet to a sound port in the microphone. Features are provided on the slidable member and main body for guiding the member into its retracted and extended positions. Also, detent features hold the member in its two positions. In one embodiment, the member covers an external face of the radiotelephone when retracted. In another embodiment, the member is housed within the main body of the radiotelephone, and a portion of the sound inlet is adjacent the microphone in the retracted position for use without extending the member.

PCT

WORLD INTELLECTUAL PROPERTY ORGANIZATION
International Bureau

INTERNATIONAL APPLICATION PUBLISHED UNDER THE PATENT COOPERATION TREATY (PCT)

<p>(51) International Patent Classification ⁶ : H04M 1/02</p>	<p>A1</p>	<p>(11) International Publication Number: WO 99/12322</p> <p>(43) International Publication Date: 11 March 1999 (11.03.99)</p>
<p>(21) International Application Number: PCT/US98/18146</p> <p>(22) International Filing Date: 1 September 1998 (01.09.98)</p> <p>(30) Priority Data: 08/923,165 4 September 1997 (04.09.97) US</p> <p>(71) Applicant: ERICSSON INC. [US/US]; 7001 Development Drive, P.O. Box 13969, Research Triangle Park, NC 27709 (US).</p> <p>(72) Inventors: BARTHA, Istvan; Montorgatan 2, Box 901, S-692 29 Kumla (SE). THORNTON, Curtis, W.; 103 Indigo Drive, Cary, NC 27513 (US).</p> <p>(74) Agents: HALL, David, C. et al.; Ericsson Inc., 7001 Development Drive, P.O. Box 13969, Research Triangle Park, NC 27709 (US).</p>	<p>(81) Designated States: AL, AM, AT, AU, AZ, BA, BB, BG, BR, BY, CA, CH, CN, CU, CZ, DE, DK, EE, ES, FI, GB, GE, GH, GM, HU, ID, IL, IS, JP, KE, KG, KP, KR, KZ, LC, LK, LR, LS, LT, LU, LV, MD, MG, MK, MN, MW, MX, NO, NZ, PL, PT, RO, RU, SD, SE, SG, SI, SK, SL, TJ, TM, TR, TT, UA, UG, UZ, VN, YU, ZW, ARIPO patent (GH, GM, KE, LS, MW, SD, SZ, UG, ZW), Eurasian patent (AM, AZ, BY, KG, KZ, MD, RU, TJ, TM), European patent (AT, BE, CH, CY, DE, DK, ES, FI, FR, GB, GR, IE, IT, LU, MC, NL, PT, SE), OAPI patent (BF, BJ, CF, CG, CI, CM, GA, GN, GW, ML, MR, NE, SN, TD, TG).</p> <p>Published <i>With international search report.</i></p>	

(54) Title: RADIOTELEPHONE WITH SLIDING ACOUSTIC MEMBER

(57) Abstract

A radiotelephone having a slidably retractable member with an acoustic duct for transmitting sound through the member into a microphone housed in the radiotelephone's main body. The member is slidable to an extended position for use such that a sound inlet of the acoustic duct is exposed for collecting sound as a person speaks into it. Sound travels through the acoustic duct and passes directly through a sound outlet into the microphone. A sealing member adjacent the microphone acoustically seals the sound outlet to a sound port in the microphone. Features are provided on the slidable member and main body for guiding the member into its retracted and extended positions. Also, detent features hold the member in its two positions. In one embodiment, the member covers an external face of the radiotelephone when retracted. In another embodiment, the member is housed within the main body of the radiotelephone, and a portion of the sound inlet is adjacent the microphone in the retracted position for use without extending the member.

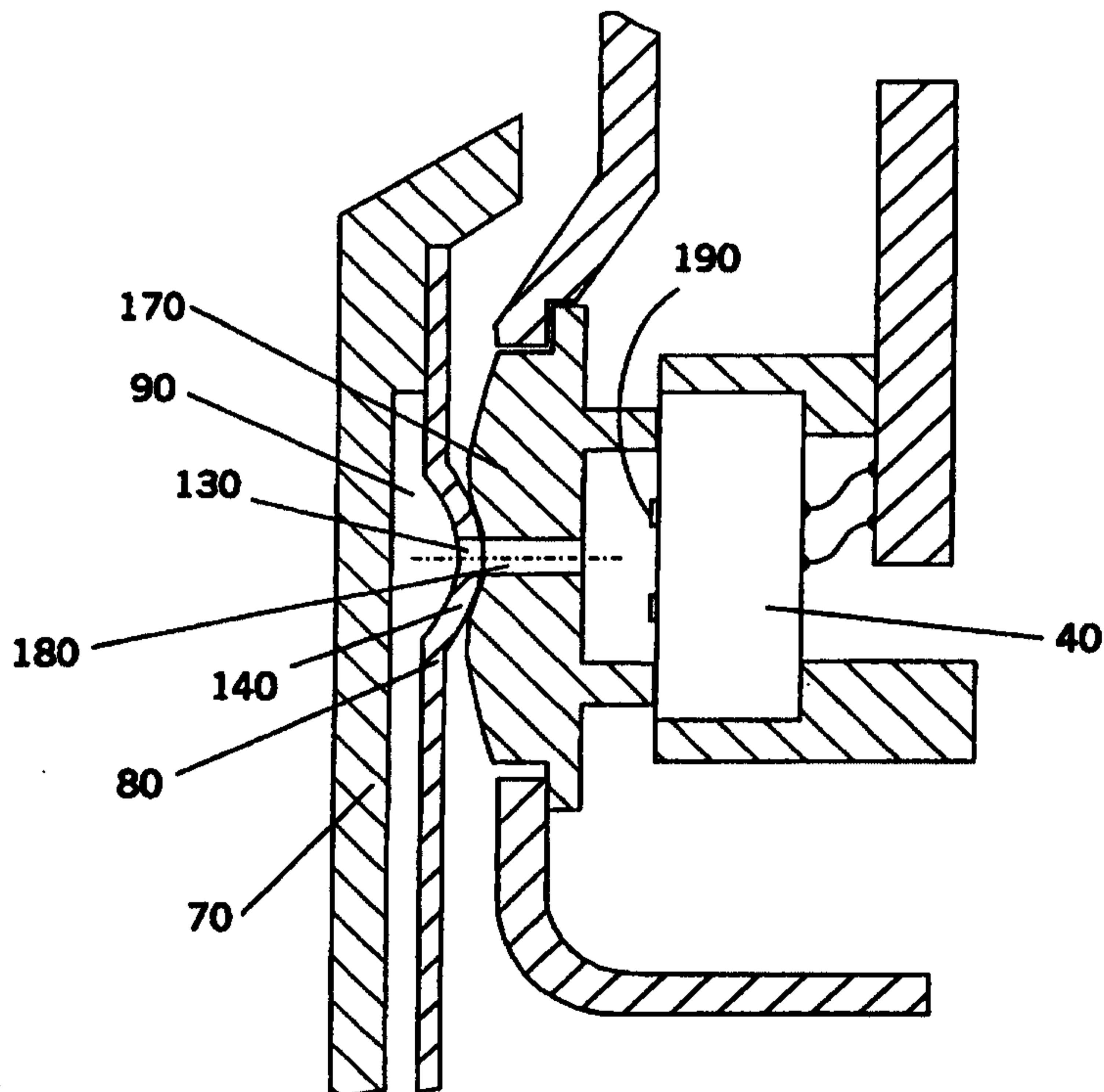

RADIOTELEPHONE WITH SLIDING ACOUSTIC MEMBER

FIELD OF THE INVENTION

This invention relates generally to portable radiotelephones, and more
5 particularly to portable radiotelephones having extending members movable by a
user.

BACKGROUND OF THE INVENTION

Portability is an increasingly important radiotelephone feature for
10 consumers; therefore, radiotelephones are being designed and produced to be
as small as possible. A common problem with small phones is that when a user
holds a phone to his or her ear during use, the microphone is positioned far from
the user's mouth, resulting in poor sound transmission. With an emphasis on
miniaturization, numerous phones on the market now have a member which is
15 compactly stowed against the phone's main body until a user extends the
member. These extending members either rotate or slide out from the main
body and are designed to enhance a phone's acoustical performance.

Many phones containing a microphone in the main body have an extending member that contains no electronics but merely acts as a surface which reflects a user's voice into the microphone when the member is extended and the phone is held to the user's ear. An example of such a radiotelephone is the model DH 338 manufactured by Ericsson Inc. Some extending members contain microphones such that when the member is extended, and the phone is held to a user's ear, the microphone is positioned near the user's mouth. The radiotelephone described in U. S. Pat. No. 4,845,772 to Metroka et al. contains a microphone in the extending member. Another type of extending member contains no electronics but does contain an acoustic duct which has an inlet that opens near a user's mouth and an outlet which opens into an aperture in the main body of the phone. The aperture in the phone leads directly to a microphone. When in use, acoustic ducts carry sound from the source to the microphone, dramatically improving sound quality and requiring no electronic parts.

At least two types of extending members with acoustic ducts are known, both of which are hinged to a phone and rotate about the hinge to an extended position for use. The first type described in European Pat. No. 275,996 B1 has an acoustic duct which opens in alignment with an opening in the main body only when the member is rotated out to its extended position. A tight fit between the extending member opening and the main body opening is required to maximize

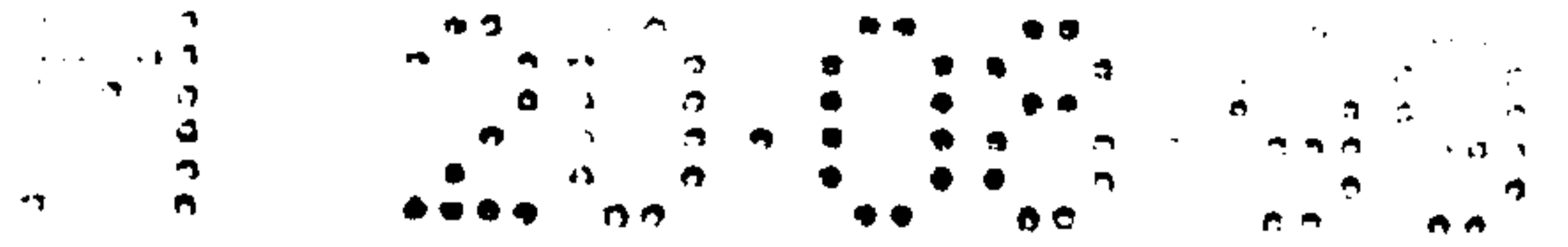

WO 99/12322

PCT/US98/18146

sound transmission. UK Patent Application No. GB 2,235,850 A describes a telephone handset comprising a body portion supporting a mouthpiece, earpiece and a keypad. The mouthpiece is located on a movable support such that it may be extended from the body portion when the handset is required for a call. When not in use, the support may be retracted. The second type embodied in Ericsson's model number AF 738 has an acoustic duct which leads through the hinge of the phone and opens in alignment with the member's axis of rotation and with an opening in the main body. Two arms of the hinge apply constant force to keep the opening of the extending member tightly abutting the opening of the main body.

10 All of the extending members described above have undesirable attributes. Firstly, although the extending member for voice reflection is inexpensive, easy to assemble, and easy to replace, it often does not reflect enough of the user's voice to adequately enhance sound quality. Secondly, when the extending member contains a microphone, there must be an electrical connection to the main body that must
15 withstand repeated movement of the extending member. Phones of this type use expensive parts, are likely to break when dropped, and are difficult to assemble and repair. Thirdly, the extending members with acoustic ducts as mentioned above are prone to wear and either lose sound through leaks between the openings in the extending member and the main body, or they require a number of expensive,
20 complicated sealing parts that are difficult to assemble.

Thus, small, portable radiotelephones are in need of extending members that are inexpensive, easy to assemble and replace, durable to repeated extensions, robust, and reliable while providing excellent acoustical performance.

SUMMARY OF INVENTION

A radiotelephone according to the present invention has an extending member that slides from a retracted position to an extended position. The extending member contains an acoustic duct with a sound inlet at the distal end of the member and a sound outlet at the proximal end of the member. The main body of the radiotelephone houses a microphone. A sealing element is disposed about the microphone and has an opening coincident with the sound port of the microphone. When the extending member is slid to its extended position, the sound outlet of the acoustic duct aligns with the opening in the sealing element. As a person comfortably holds the radiotelephone to his or her ear and speaks toward the phone's extending member, voice is transmitted into the sound inlet, through the acoustic duct, through the sound outlet, through the sealing element, and into the microphone. The sealing element ensures a sound path with minimal leakage between the sound inlet and the microphone.

In a first embodiment, the extending member is external to the radiotelephone in both retracted and extended positions. In both positions, the extending member covers the portion of the radiotelephone housing the microphone to protect the microphone from contaminants. In a second embodiment, the extending member is internal to the radiotelephone in the retracted position. This aspect of the invention enables storage of the extending member without having to conceal a portion of the radiotelephone.

In another aspect, the invention provides a radiotelephone, comprising a main body containing a microphone, a member having a distal end and a proximal end, the member being slidably connected to the main body and comprising an acoustic duct for carrying sound, the acoustic duct having at least one sound inlet at the distal end of the member and a sound outlet at the proximal end of the member, the member having an extended position wherein the member is slid away from the main body such that the sound inlet of the acoustic duct is exposed for sound collection and the sound outlet of the acoustic duct is positioned adjacent the microphone for sound transmission, the member having a retracted position wherein the member is slid toward the main body for storage, wherein the sound inlet of the acoustic duct is located adjacent the microphone for transmitting sound directly from the sound inlet of the acoustic duct to the microphone when the member is in the retracted position such that sound may be transmitted to the microphone when the member is in either of the retracted and extended positions, and a sealing element disposed adjacent the microphone, wherein, when the member is in the retracted position, the sealing element acoustically seals at least a portion of the sound inlet of the acoustic duct to the microphone.

In another aspect, the invention provides a radiotelephone, comprising a main body, a microphone disposed within the main body and comprising a sound port, a member having a distal end and a proximal end, the member being slidably connected to the main body and comprising an acoustic duct for carrying sound, the acoustic duct having at least one sound inlet at the distal end of the member and a sound outlet at the proximal end of the member, the member having an extended position wherein the member is slid away from the main body such that the sound inlet of the acoustic duct is exposed for sound collection and the sound outlet of the acoustic duct is positioned adjacent the microphone for sound transmission, the member having a retracted position wherein the member is slid toward the main body for storage, wherein the sound inlet of the acoustic duct is located adjacent the microphone for transmitting sound directly from the sound inlet of the acoustic duct to the microphone when the member is in the retracted position such that sound may be transmitted to the microphone when the member is in either of the retracted and extended

positions, and a sealing element disposed adjacent the microphone, wherein the sealing element acoustically seals the acoustic duct sound outlet to the microphone sound port when the member is in the extended position, and wherein the sealing element acoustically seals at least a portion of the acoustic duct sound inlet to the microphone sound port when the member is in the retracted position.

BRIEF DESCRIPTION OF THE DRAWINGS

FIG. 1 is a front view of a radiotelephone in accordance with a first
5 embodiment of the invention showing an extending member in an extended
position.

FIG. 2 is a front view of a radiotelephone with an extending member in a
retracted position.

FIG. 3 is a back view of an extending member showing an assembled lid
10 and label.

FIG. 4 is a back view of an extending member showing a lid with its label
removed.

FIG. 5 is a front view of an extending member showing a sound inlet.

FIG. 6 is a cross-sectional view of the extending member through the
15 acoustic duct.

FIG. 7 is a partial cross-sectional view of the extending member.

FIG. 8 is a front view of the main body of a radiotelephone with a partial
cut-away view of the grooved track and detents.

FIG. 9 is a cross-sectional view through the microphone when the
20 extending member is in the extended position.

FIG. 10 is a perspective view of a second embodiment of the invention.

FIG. 11 is a side view of the second embodiment of the invention.

FIG. 12 is a cross-sectional view through the microphone of the second embodiment with the extending member extended.

FIG. 13 is a cross-sectional view through the microphone of the second embodiment with the extending member retracted.

5

DETAILED DESCRIPTION OF THE INVENTION

FIGS. 1 and **2** show an assembled radiotelephone **10** employing a first embodiment of the invention. As illustrated in **FIG. 1**, the radiotelephone **10** has a main body **20** and an extending member **30**. A microphone **40**, shown with hidden lines, is contained within the main body **20**. The extending member **30** is slidable along the main body **20** between an extended position shown in **FIG. 1** and a retracted position shown in **FIG. 2**. Preferably, the extending member **30** protectively covers at least a portion of a front face **50** of the main body **20** when slid to the retracted position for storage. In the extended position, the radiotelephone **10** is arranged for use, and the front face **50** is revealed to expose user interface apparatus such as a keypad **60**.

More specific details of the extending member **30** are illustrated in **FIGS. 3-7**. **FIG. 3** shows the underside of a complete extending member **30**. The extending member **30** is primarily composed of two parts: a lid **70** and a label **80**, both made typically of plastic, though metal and other materials may be used. **FIG. 4** shows the underside of an extending member **30** with the label **80**

20

removed. The lid 70 is preferably an injection molded part having an integral acoustic duct 90 and sound inlet 100. The acoustic duct 90 extends between a distal end 111 and a proximal end 112 of the extending member 30. The sound inlet 100 is a through-hole in the acoustic duct 90 at the distal end 111 of the extending member 30. The top side of the extending member 30 is illustrated in FIG. 5. FIG. 7 is a partial cross-section showing an inwardly-extending projection 121 on the lid 70. A similar projection is arranged on the opposite side of the lid 70 (FIG. 4). Detent features 110 are provided as flexible protrusions on projections 121 of the lid 70 at the proximal end 112 of the extending member 30. Finger grips 120 may also be provided on the extending member 30 to aid sliding.

The label 80, shown assembled with the lid 70 in FIG. 3, is simply a thin sheet of plastic having an integral sound outlet 130. The sound outlet 130 is a hole through the label 80. A convex region 140 may also be disposed about the sound outlet 130. The label 80 is glued, ultrasonically welded, or otherwise secured in a fixed relationship to the lid 70 such that the sound outlet 130 is in acoustic communication with the acoustic duct 90 at the proximal end 112 of the extending member 30. Upon assembling the label 80 to the lid 70, the acoustic duct 90 is covered and concealed except for the sound inlet 100 and sound outlet 130. As illustrated by the cross-section shown in FIG. 6, the sound inlet 100 opens at the distal end of the acoustic duct 90 to receive sound, and the

sound outlet **130** opens at the proximal end of the acoustic duct **90** to transmit sound. In the preferred embodiment just described, the lid **70** and label **80** are simple and lack delicate parts. The resulting extending member **30** is easily and cheaply produced and is not susceptible to breakage and wear. Extending
5 members according to the invention may be comprised of more or less parts, and their exact features and manufacturing methods may vary according to specific design requirements.

FIGS. 8 and **9** show more details of the radiotelephone **10** with particular attention given to features of the main body **20**. A grooved track **150** and its
10 detent features **160** on one side of the main body **20** are illustrated in the cut-away section shown in **FIG. 8**. A similar track and detent features are likewise provided on the opposite side of the main body **20**. Also shown in **FIG. 8** is a sealing element **170** which is secured to the main body and which has an opening **180**. Both the sealing element **170** and its opening **180** are accessible
15 external to the main body **20** of the radiotelephone. As demonstrated in **FIG. 9**, the sealing element **170** is disposed adjacent the microphone **40** with the opening **180** in fixed alignment with a sound port **190** of the microphone **40**. The sealing element **170** is preferably an inexpensive grommet comprised of a compressible, closed-cell foam rubber.

20 To assemble the extending member **30** onto the main body **20**, the projections **121** on each side of the lid **70** (**FIGS. 3, 4**) are snapped into or slid

WO 99/12322

PCT/US98/18146

onto the track **150** of the main body **20** (**FIG. 8**). Detent features **110** on the extending member **30** mate with detent features **160** in the track **150** of the main body **20** to maintain the extending member **30** in its retracted and extended positions. Other types of configurations are also envisioned for guiding the extending member **30** as it slides along the main body **20**. For example, guide rails could be located on the front face **50** of the main body **20** with corresponding channels on the extending member **30**. Many devices such as spring-loaded pins and other releasable locking mechanisms may be used for holding the extending member **30** in its retracted and extended positions.

Once assembled, the extending member **30** is normally maintained in its retracted position (**FIG. 2**) while the radiotelephone **10** is in standby mode, ready to receive calls. In this position, the acoustic duct **90** is non-operable, and the opening **180** of the sealing element **170** is concealed by the extending member **30** such that dirt and other contaminants may not enter the opening **180** and damage the microphone **40**.

When the user decides to answer an incoming call, to place a call, or to access features concealed by the extending member **30**, he or she slides the extending member **30** down the main body **20** of the radiotelephone **10** to the extended position (**FIG. 1**) where it is held in place by the detent features **110** and **160** on the extending member **30** and main body **20**, respectively. In the extended position, the sound outlet **130** of the acoustic duct **90** aligns with the

WO 99/12322

PCT/US98/18146

opening **180** in the sealing element **170** as shown in the cross-section of **FIG. 9**.
When the user comfortably places the radiotelephone **10** against his or her ear,
the sound inlet **100** of the extending member **30** is located in close proximity to
the user's mouth. Accordingly, as the user speaks, sound is projected into the
5 sound inlet **100**. As seen in **FIGS. 6** and **9**, the sound travels from the sound
inlet **100**, through the acoustic duct **90**, through the sound outlet **130**, through
the opening **180** in the sealing element **170**, and into the sound port **190** of the
microphone **40**. The tight abutment of the sound outlet **130** against the sealing
element **170**, facilitated by convex region **140**, (**FIG. 9**) ensures very minimal
10 sound leakage between the sound inlet **100** of the acoustic duct **90** and the
microphone **40** in the main body **20** of the radiotelephone **10**. The result is very
good sound transmittal.

An alternative embodiment of the invention is depicted in **FIGS. 10-13**.

An extending member **210** slides from a retracted position within a main body
15 **220** of the radiotelephone **200** to an extended position (**FIGS. 10, 11**) external to
the main body **220** of the radiotelephone **200**. The construction of the extending
member **210** in this embodiment is very similar to that of the embodiment
previously described. The extending member **210** preferably comprises two
main parts: a lid **230** and a label **240** (**FIGS. 12, 13**). In this embodiment, both a
20 sound inlet **250** (**FIG. 10**) and a sound outlet **270** (**FIG. 12**) are formed in the lid.
The sound inlet **250** in the lid **230** leads into an acoustic duct **260** (**FIG. 12**)

WO 99/12322

PCT/US98/18146

which terminates with a sound outlet **270** in the lid **230**. As shown in **FIG. 12**, a dimple **280** is preferably disposed about the sound outlet **270** to serve as a detent feature.

The label **240** is simply a strip of plastic secured to the lid **230** by gluing, ultrasonically welding, or other fastening technology. As shown by **FIGS. 12** and **13**, the label **240** forms a part of the acoustic duct **260** and provides for easy assembly.

The radiotelephone **200** and extending member **210** shown in **FIGS. 10-13** are slender, elongated components; however, the shape of these components may vary according to design requirements.

The main body of the radiotelephone **200** includes a channel **290** (**FIG. 12**) which houses the extending member **210** in the retracted position and guides it to the extended position. Alternatively, a rib in the main body **220** and a groove in the extending member **210** could serve as guide features, for example. As shown in **FIG. 12**, a microphone **300** is contained in the main body **220** and is at least partly encompassed by a sealing element **310**. An opening **320** in the sealing element **310** is positioned in fixed alignment with a sound port **330** of the microphone **300**. A convex region **340** is disposed about the opening **320** in the sealing element **310** to serve as a detent feature matable with the dimple **280** disposed about the sound outlet **270** in the extending member **210**. The sealing element **310** is preferably comprised of a compressible, closed-cell

foam rubber and may be secured directly to the microphone **300** (**FIG. 12**) or to the main body **220**.

When the extending member **210** is slid to the extended position as shown in **FIG. 12**, the sound outlet **270** aligns with the opening **320** in the sealing element **310** to form an acoustic path from the sound inlet **250** to the microphone **300**. The dimple **280** disposed about the sound outlet **270** mates with the convex region **340** of the sealing element **310** to securely maintain the extending member **210** in the extended position. The sealing member **210** compresses to form a tight seal against the extending member **210**, thereby preventing sound leakage between the two components.

When the extending member **210** is slid to the retracted position, sound may still be transmitted from the sound inlet **250** to the microphone **300**. As shown in **FIG. 13**, the retracted position enables a portion of the sound inlet **250** to be in acoustic communication with the opening **320** in the sealing element **310**. With this configuration, sound travels into the sound inlet **250**, through the sealing element **310**, and to a sound port **330** of the microphone **300**. The acoustic duct **260** is essentially bypassed although some sound is expected to enter it. This embodiment allows the user to talk on the radiotelephone **200** with the extending member **210** in either retracted or extended positions.

In all embodiments, an off-hook mode of the radiotelephone could be activated by a hookswitch as the extending member is slid to the extended

position. As the embodiment of **FIGS. 10-13** suggests, to make or answer a call with the extending member **210** retracted, the user would have to press a button or otherwise activate the off-hook mode.

In accordance with the invention as described above, various
5 modifications and alterations may be made by one skilled in the art without deviating from the scope of the invention as defined in the following claims.

The embodiments of the invention in which an exclusive property or privilege is claimed are defined as follows:

1. A radiotelephone, comprising:
 - a main body containing a microphone;
 - a member having a distal end and a proximal end, said member being slidably connected to said main body and comprising an acoustic duct for carrying sound, said acoustic duct having at least one sound inlet at the distal end of said member and a sound outlet at the proximal end of said member, said member having an extended position wherein said member is slid away from said main body such that the sound inlet of said acoustic duct is exposed for sound collection and the sound outlet of said acoustic duct is positioned adjacent said microphone for sound transmission, said member having a retracted position wherein said member is slid toward said main body for storage, wherein the sound inlet of said acoustic duct is located adjacent said microphone for transmitting sound directly from the sound inlet of said acoustic duct to said microphone when said member is in the retracted position such that sound may be transmitted to said microphone when said member is in either of the retracted and extended positions; and
 - a sealing element disposed adjacent said microphone, wherein, when said member is in the retracted position, said sealing element acoustically seals at least a portion of the sound inlet of said acoustic duct to said microphone.
2. The radiotelephone of claim 1, further comprising a sound port in said microphone for receiving sound.
3. The radiotelephone of claim 1, wherein said sealing element is a compressible grommet secured adjacent said microphone.
4. The radiotelephone of claim 2, further comprising a sealing element disposed adjacent the sound port of said microphone, said sealing element acoustically sealing the sound outlet of said acoustic duct to the sound port of said microphone when said member is in the extended position.

5. The radiotelephone of claim 4, wherein said sealing element is a compressible grommet secured adjacent the microphone, said grommet having an aperture aligning with the sound port of said microphone.
6. The radiotelephone of any one of claims 1 to 5, wherein said member is exterior of said body in both retracted and extended positions.
7. The radiotelephone of claim 6, wherein said main body further comprises:
 - a top end and a bottom end opposite said top end; and
 - a grooved track positioned along a direction from the top end to the bottom end of said main body;wherein said member further comprises a projection slidably matable with said track for securing said member to said main body and for guiding said member between its retracted and extended positions.
8. The radiotelephone of claim 7, further comprising:
 - a first detent feature on said main body, and
 - a second detent feature on said member, matable with the first detent feature and releasably locking said member to said main body when said member is slid to the extended position.
9. The radiotelephone of claim 8, wherein the first detent feature comprises a recessed area in the track of said main body, and the second detent feature comprises a protuberance on the projection of said member.
10. The radiotelephone of claim 4, wherein when said member is in the retracted position, said sealing element acoustically seals at least a portion of the sound inlet of said acoustic duct to said microphone.
11. The radiotelephone of any one of claims 1 to 5, wherein said member is interior of said main body in the retracted position.

12. The radiotelephone of claim 11, further comprising a channel in said main body, said member being housed in said channel when said member is slid to the retracted position.

13. The radiotelephone of claim 11, wherein said member further comprises means for securing said member in the extended position.

14. The radiotelephone of claim 11, wherein said securing means comprises a dimple about the sound outlet of said acoustic duct and a bulge in said sealing element about the microphone sound port, the dimple mating with the bulge for securing said member in the extended position.

15. A radiotelephone, comprising:

a main body;

a microphone disposed within the main body and comprising a sound port;

a member having a distal end and a proximal end, said member being slidably connected to said main body and comprising an acoustic duct for carrying sound, said acoustic duct having at least one sound inlet at the distal end of said member and a sound outlet at the proximal end of said member, said member having an extended position wherein said member is slid away from said main body such that the sound inlet of said acoustic duct is exposed for sound collection and the sound outlet of said acoustic duct is positioned adjacent said microphone for sound transmission, said member having a retracted position wherein said member is slid toward said main body for storage, wherein the sound inlet of said acoustic duct is located adjacent said microphone for transmitting sound directly from the sound inlet of said acoustic duct to said microphone when said member is in the retracted position such that sound may be transmitted to said microphone when said member is in either of the retracted and extended positions; and

a sealing element disposed adjacent said microphone;

wherein said sealing element acoustically seals said acoustic duct sound outlet to said microphone sound port when said member is in the extended position; and

wherein said sealing element acoustically seals at least a portion of said acoustic duct sound inlet to said microphone sound port when said member is in the retracted position.

16. The radiotelephone of claim 15, wherein said sealing element is a compressible grommet secured adjacent said microphone.

17. The radiotelephone of claim 15, wherein said sealing element is a compressible grommet secured adjacent said microphone, said grommet having an aperture aligning with said microphone sound port.

18. The radiotelephone of any one of claims 15 to 17, wherein said member is exterior of said main body in both retracted and extended positions.

19. The radiotelephone of any one of claims 15 to 18, wherein said main body further comprises:

a top end and a bottom end opposite said top end; and

a grooved track positioned along a direction from the top end to the bottom end of said main body;

wherein said member further comprises a projection slidably matable with said track for securing said member to said main body and for guiding said member between its retracted and extended positions.

20. The radiotelephone of claim 19, further comprising:

a first detent feature on said main body; and

a second detent feature on said member, matable with the first detent feature and releasably locking said member to said main body when said member is slid to the extended position.

21. The radiotelephone of claim 20, wherein the first detent feature comprises a recessed area in the track of said main body, and the second detent feature comprises a protuberance on the projection of said member.

22. The radiotelephone of claim 21, wherein said member is interior of said main body in the retracted position.

23. The radiotelephone of claim 22, further comprising a channel in said main body, said member being housed in said channel when said member is slid to the retracted position.

24. The radiotelephone of claim 22, wherein said member further comprises means for securing said member in the extended position.

25. The radiotelephone of claim 22, wherein said securing means comprises a dimple about said acoustic duct sound outlet and a bulge in said sealing element about said microphone sound port, said dimple mating with said bulge for securing said member in the extended position.

FIG. 1

FIG. 2

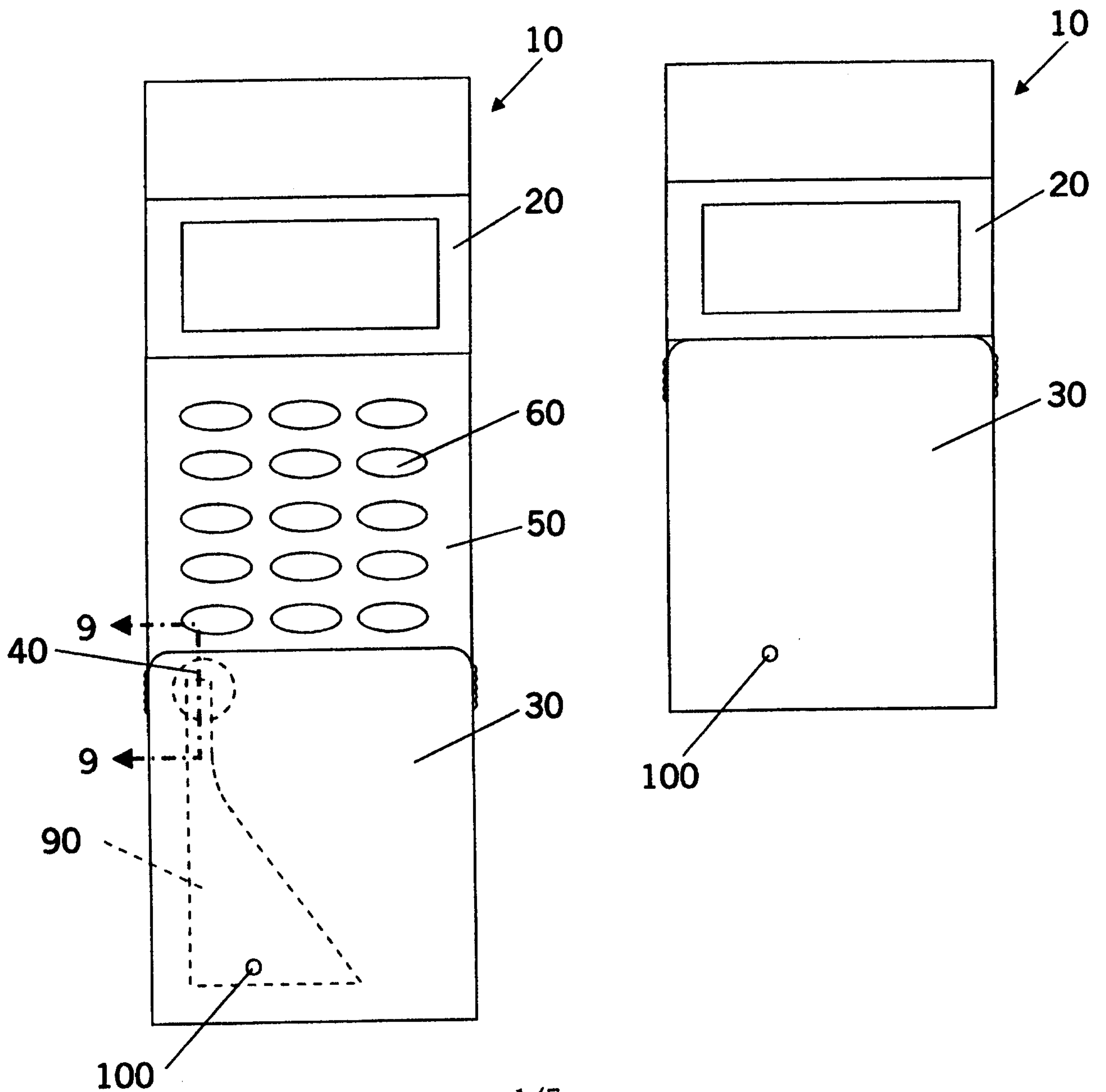

FIG. 3

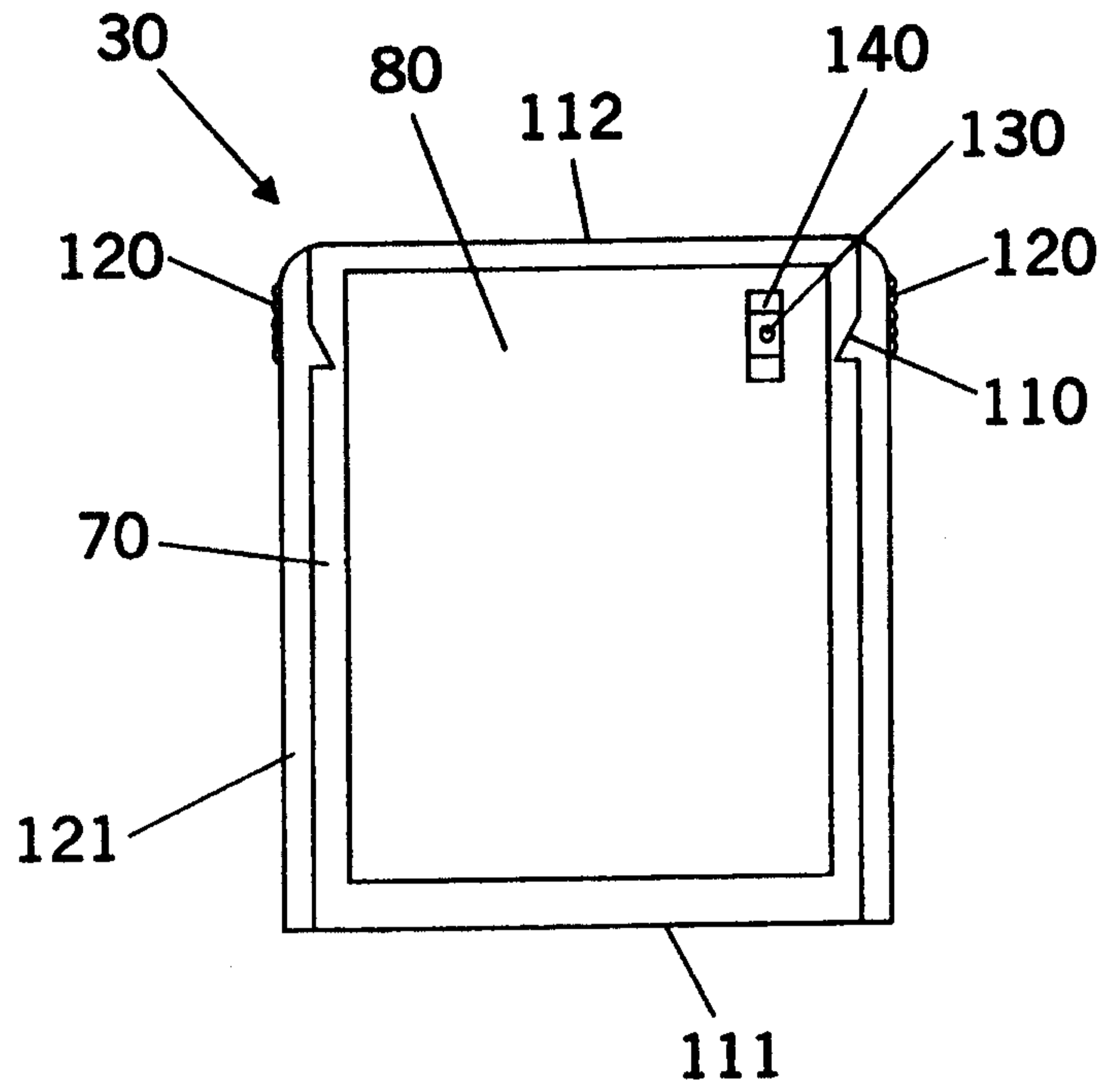

FIG. 4

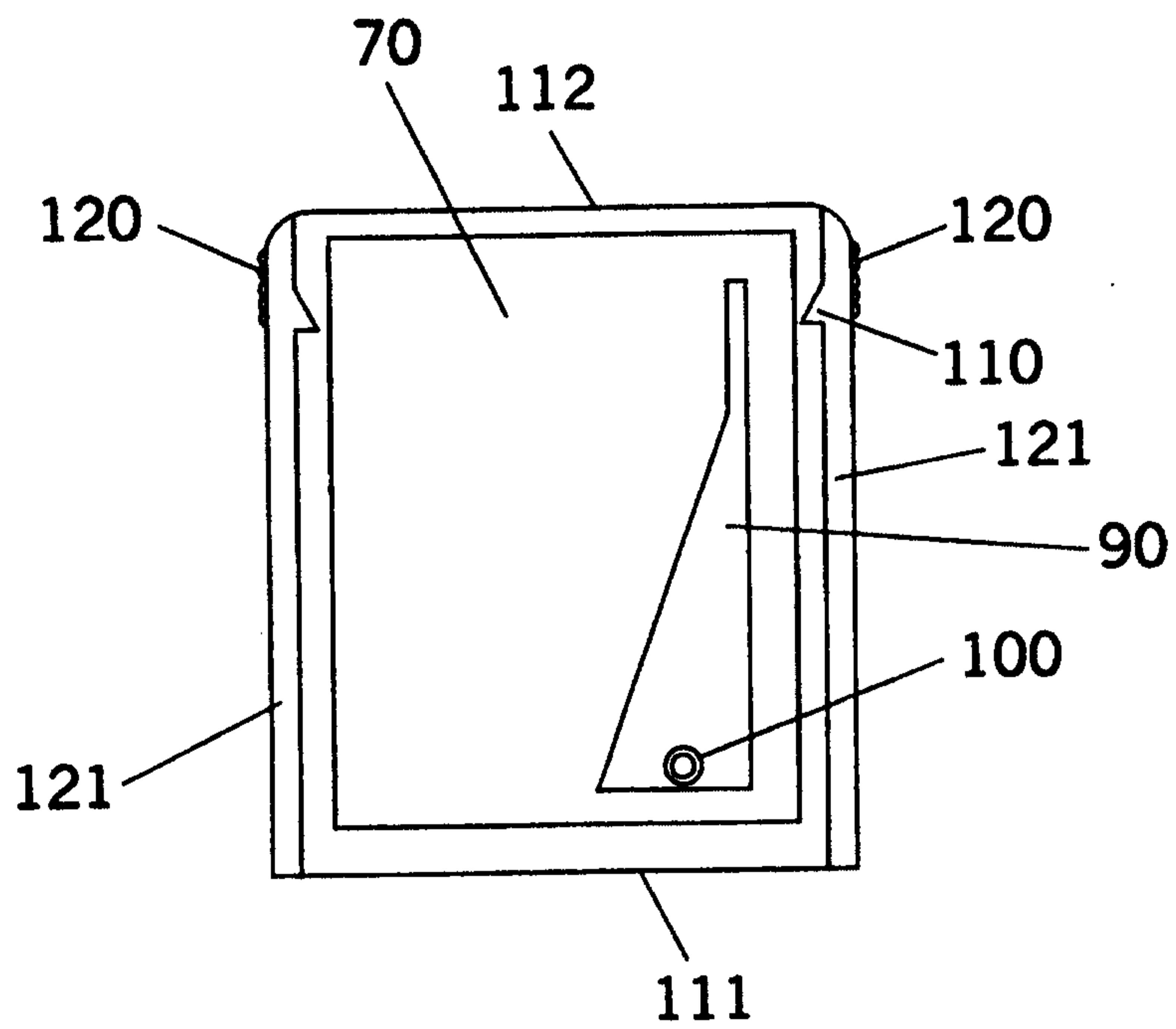

FIG. 5

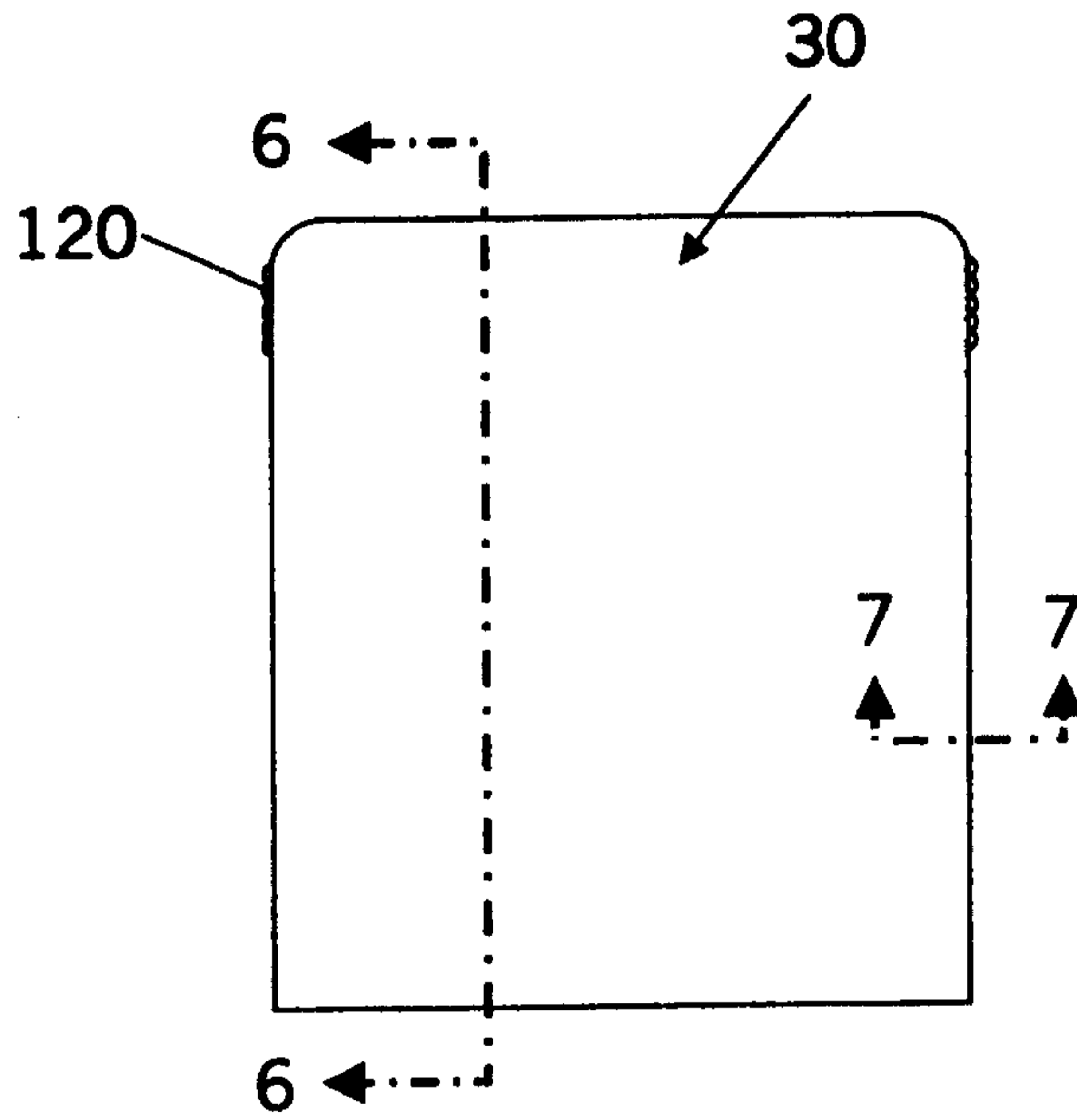

FIG. 6

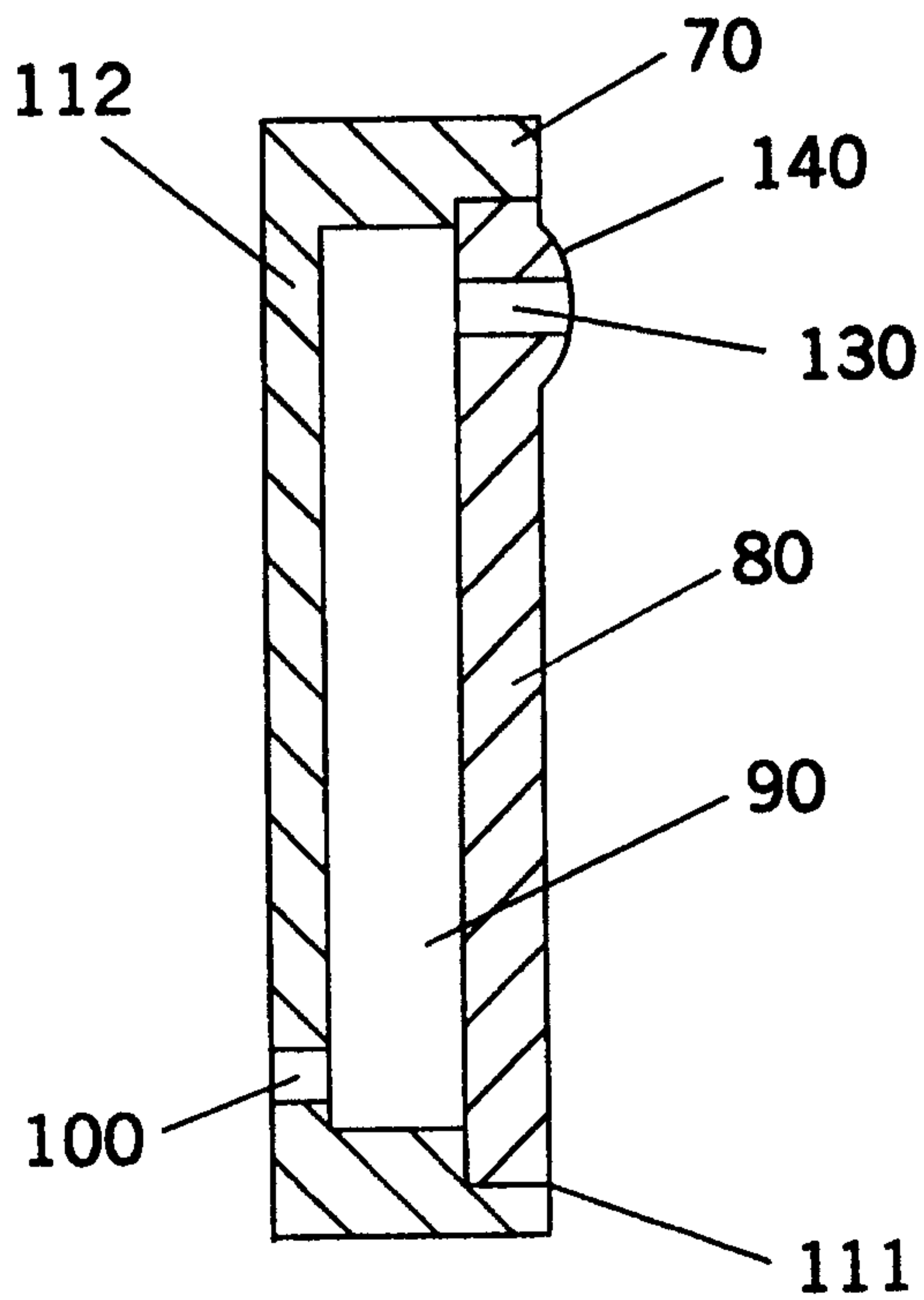

FIG. 7

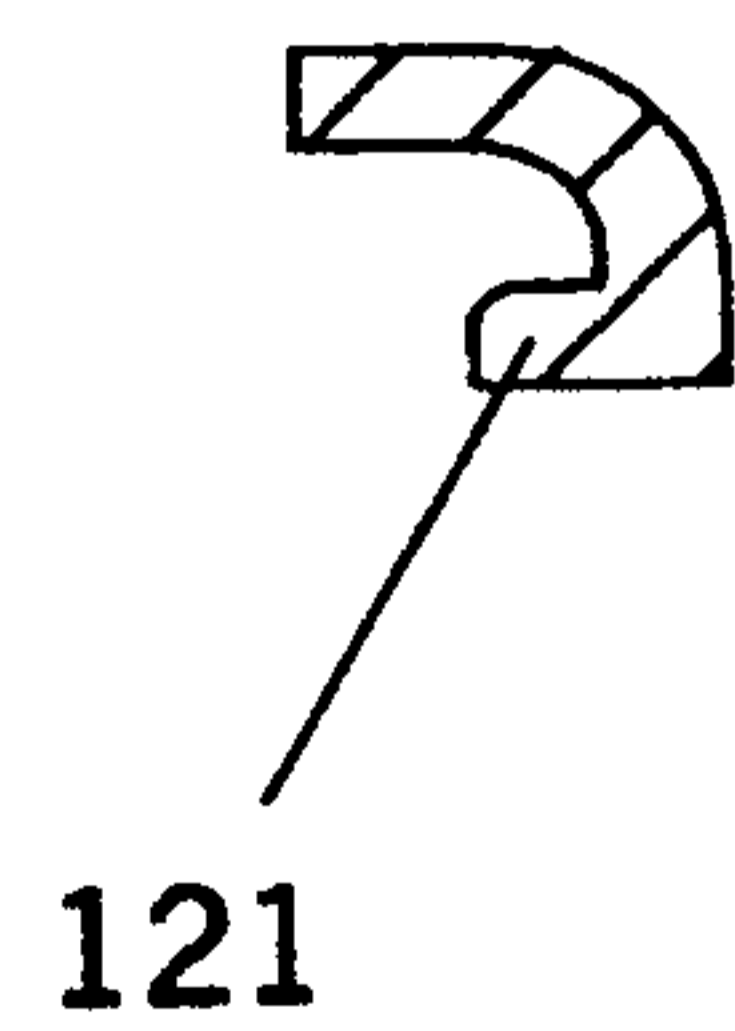

FIG. 8

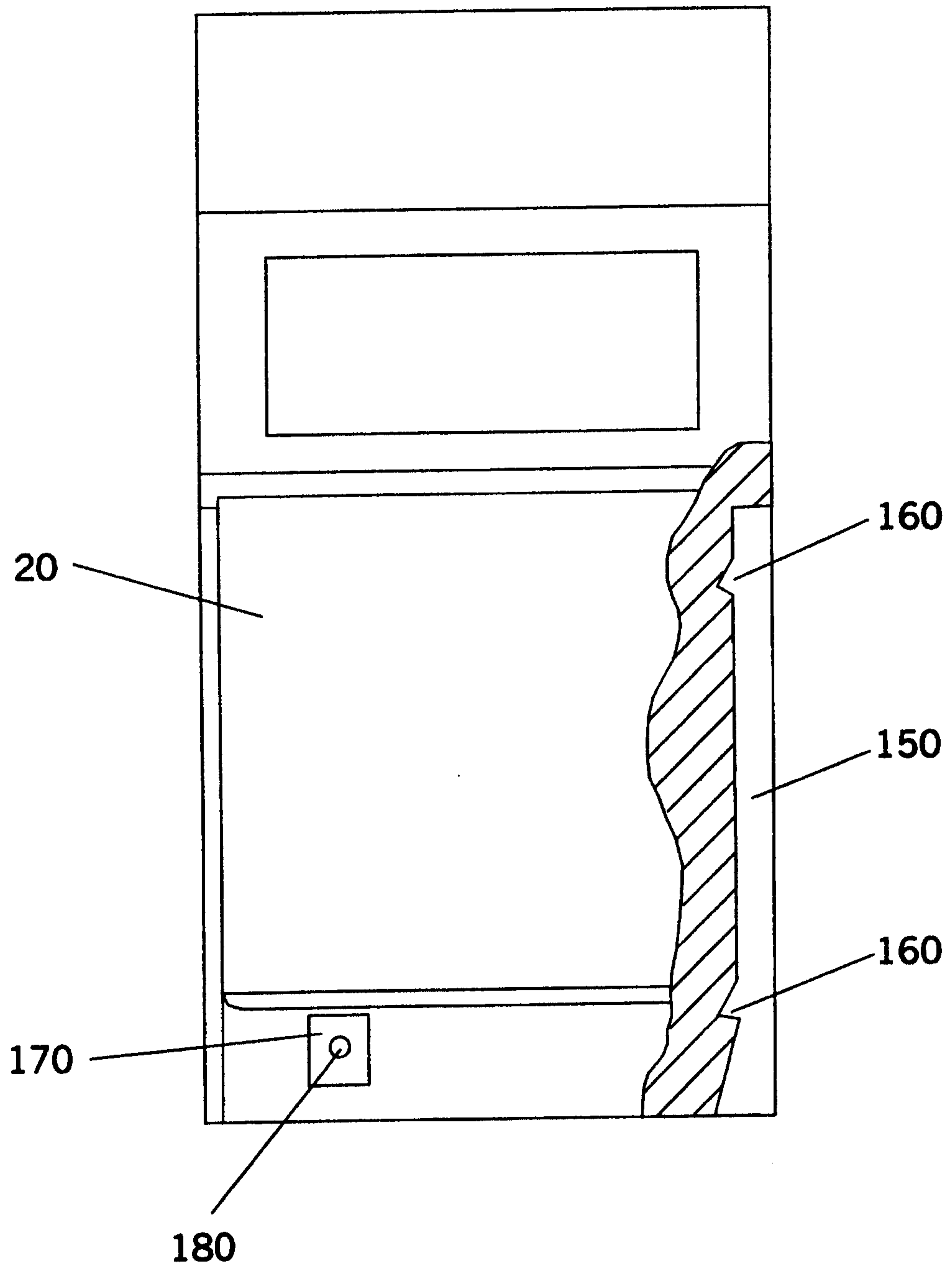
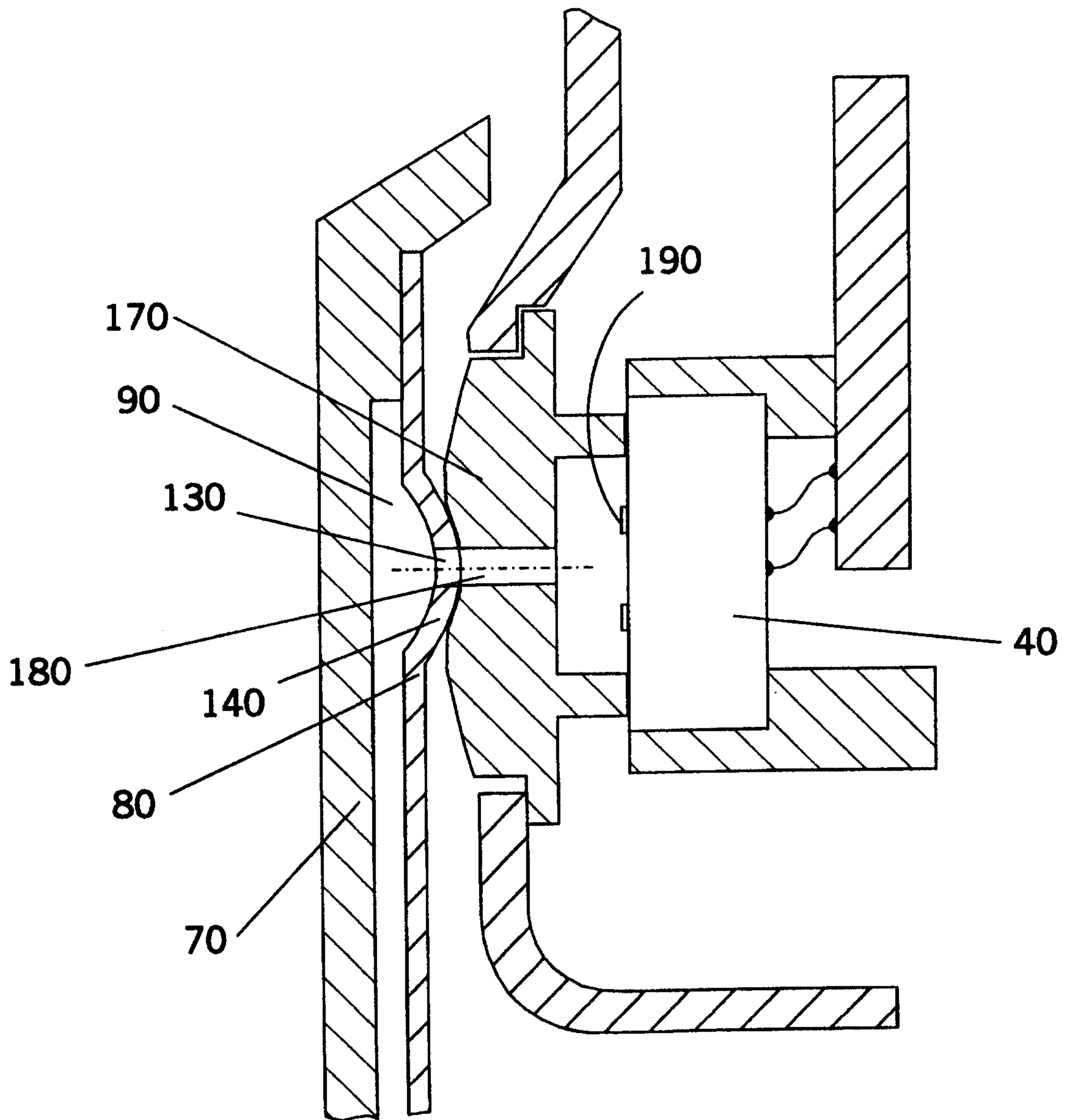

FIG. 9



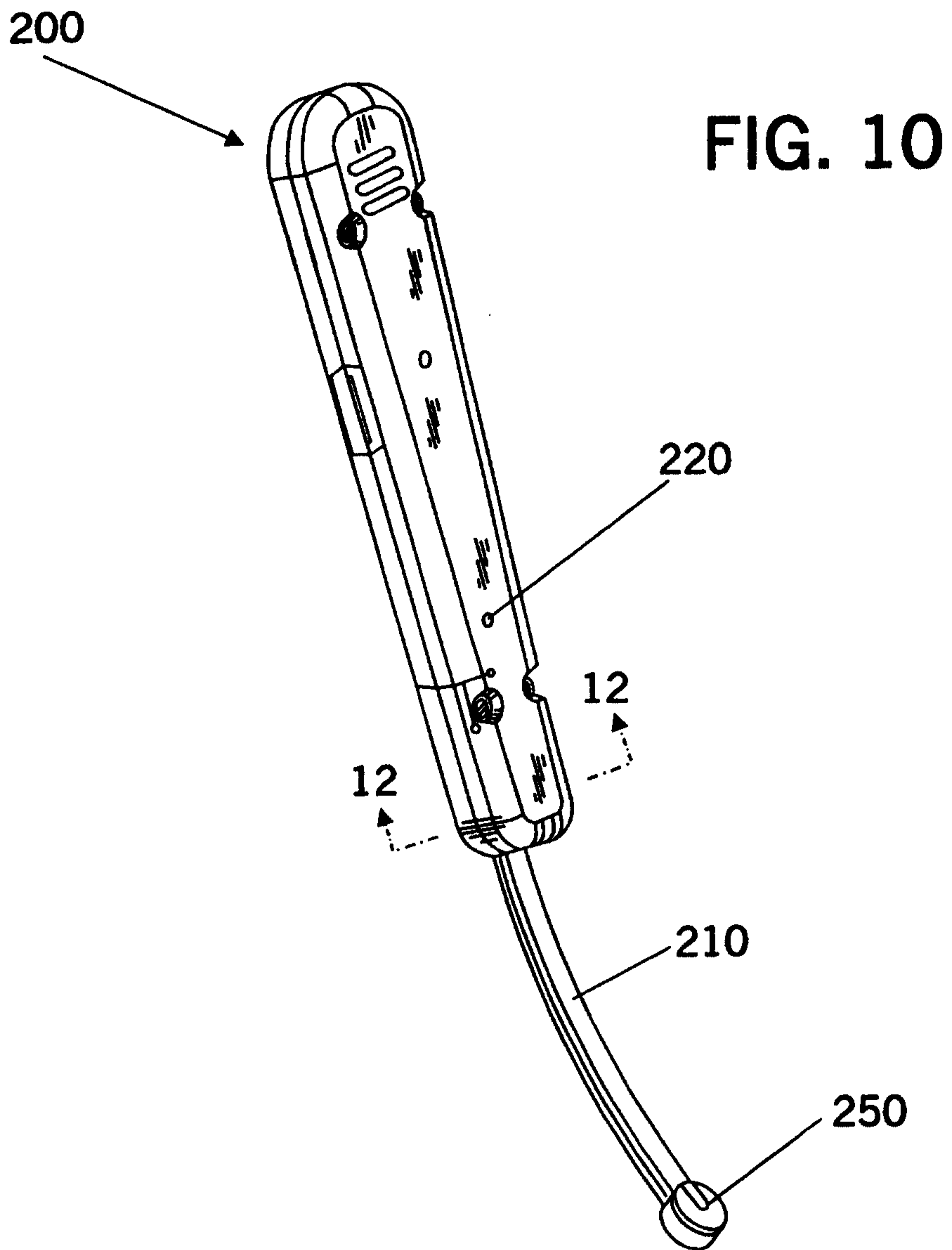

FIG. 11

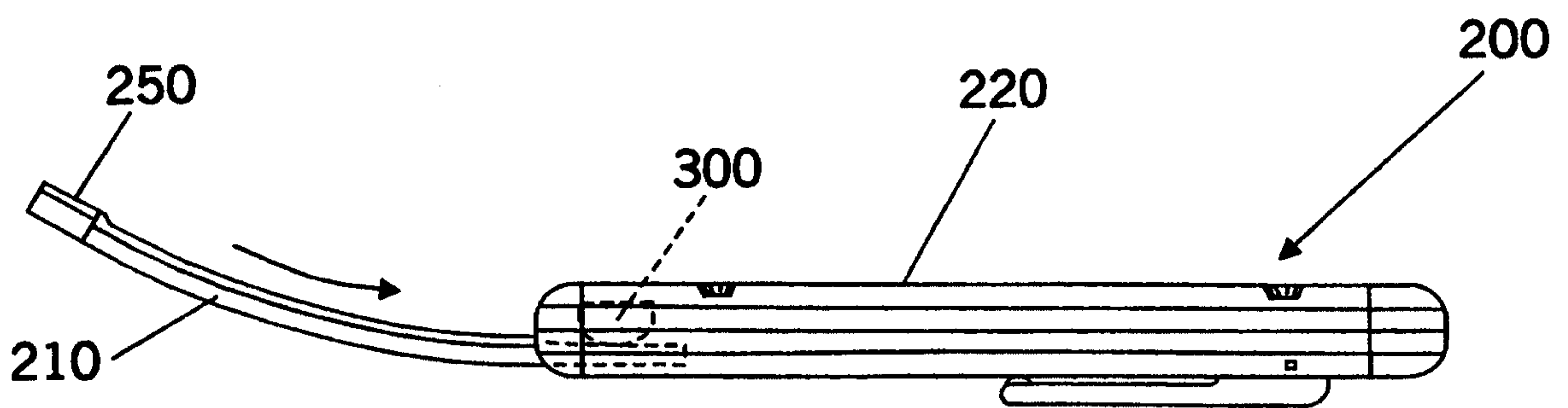

FIG. 12

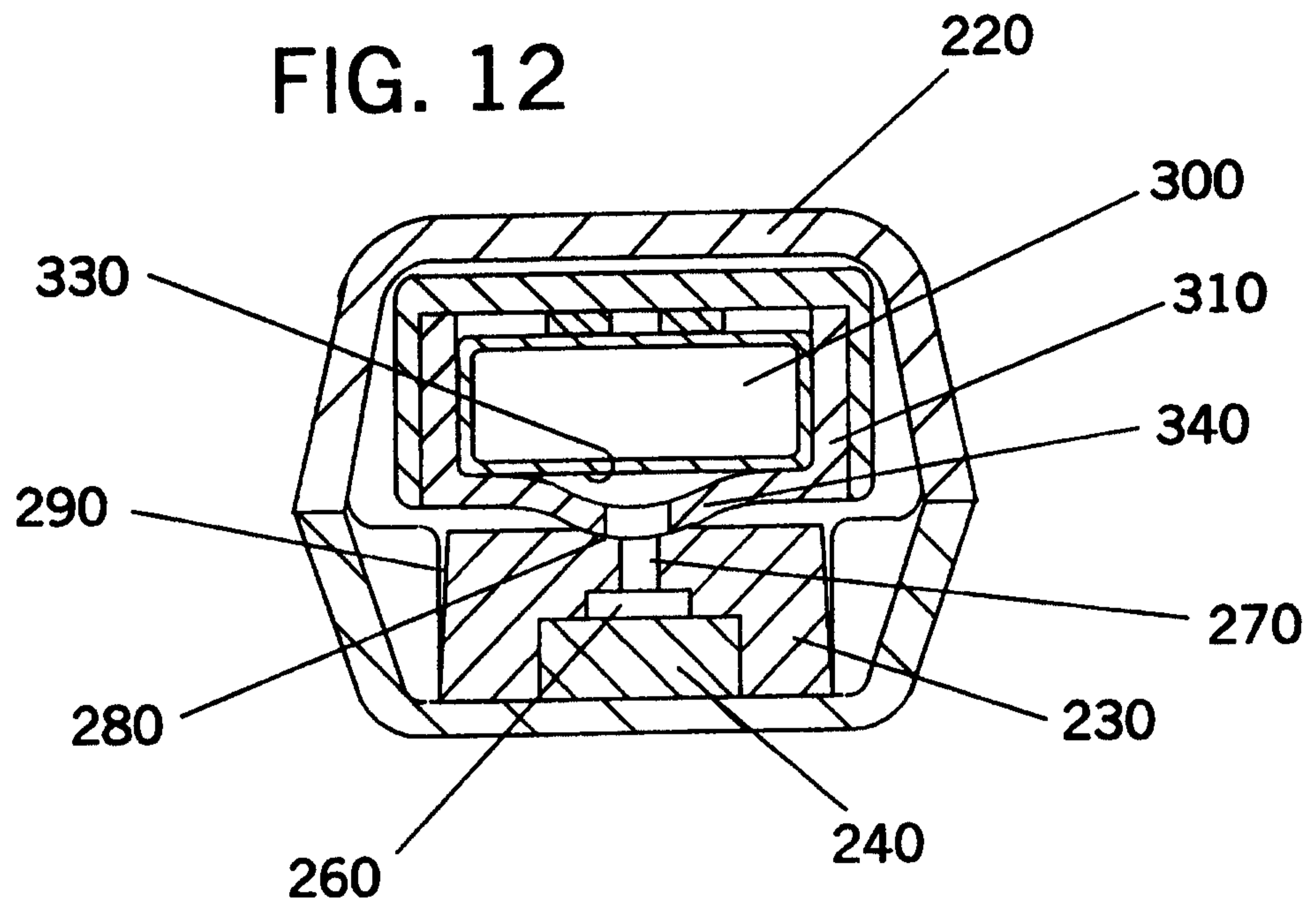

FIG. 13

