

J. M. PETERSEN.

MACHINE FOR FITTING THE ENDS OF BAND SAWS.

No. 399,344.

Patented Mar. 12, 1889.

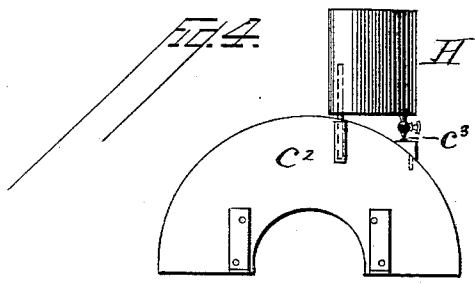
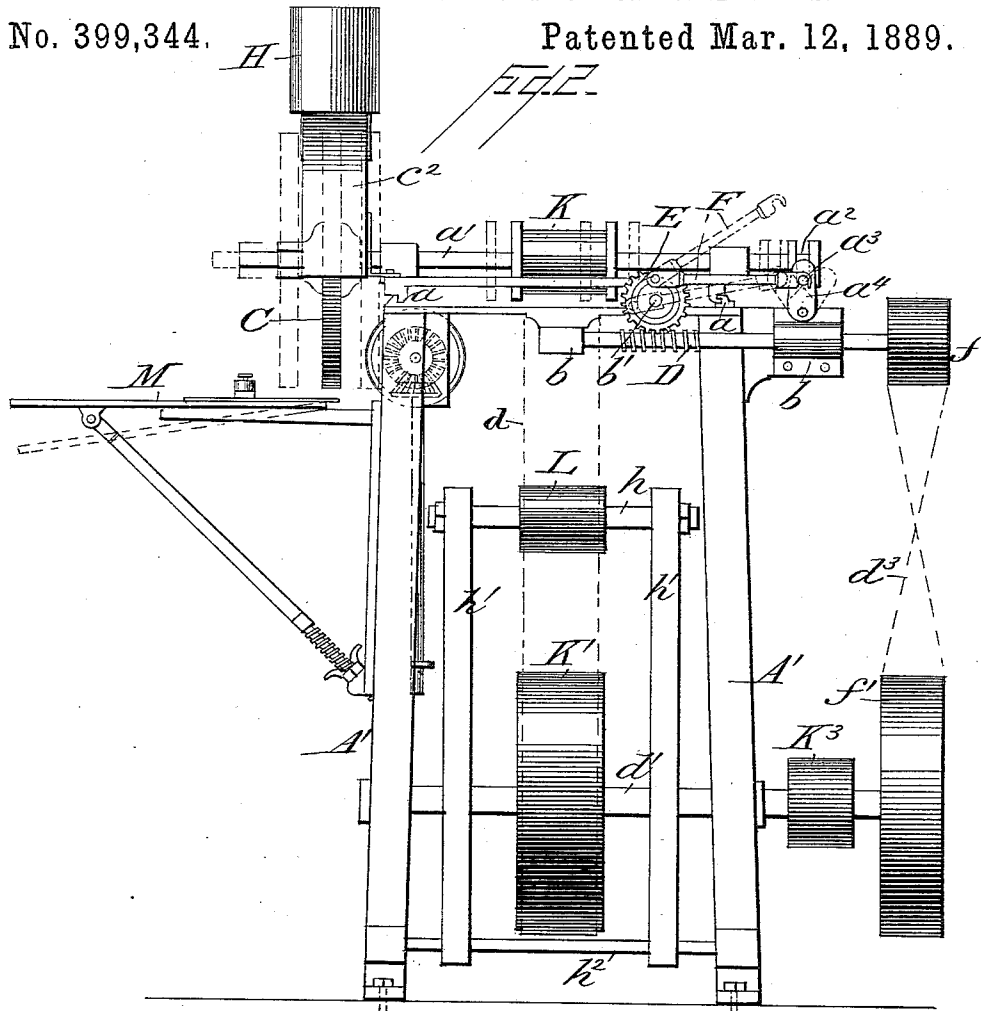

Witnesses,
J. H. Schott
H. A. Daniels,

Inventor,
J. M. Petersen
 By *W. P. Purvis*
 Attorney.

UNITED STATES PATENT OFFICE.

JENS MORITZ PETERSEN, OF CLINTON, IOWA.

MACHINE FOR FITTING THE ENDS OF BAND-SAWS.

SPECIFICATION forming part of Letters Patent No. 399,344, dated March 12, 1889.

Application filed June 16, 1888. Serial No. 277,302. (No model.)

To all whom it may concern:

Be it known that I, JENS MORITZ PETERSEN, a citizen of the United States of America, residing at Clinton, in the county of Clinton and State of Iowa, have invented certain new and useful Improvements in Machines for Fitting the Ends of Band-Saws Preparatory to Brazing them Together, of which the following is a specification, reference being had therein to the accompanying drawings.

My invention relates to machines for fitting the ends of band-saws preparatory to brazing them together; and the invention consists of certain improvements in the machine for which Letters Patent No. 341,939 were granted me May 18, 1886, as hereinafter fully set forth and claimed.

In the accompanying drawings, Figure 1 is a plan view of my improved machine. Fig. 2 is an end elevation of the same. Fig. 3 is a section on line $x x$, looking in the direction of the arrow in Fig. 1. Fig. 4 is a side view of the wheel-guard and the tank detached.

A designates the supporting-frame of the machine.

B is a carriage constructed to be reciprocated upon guides a , formed on or attached to the bed of the frame.

C designates an emery-wheel or grindstone mounted on the shaft a' , having its bearings upon the carriage. The back end of this shaft is provided with an annular groove, a^2 , to receive the oscillating bar a^3 , mounted in the oscillating bearings a^4 , which bearings are pivotally connected with the brackets a^5 of the machine-frame, for the purpose hereinafter stated.

D designates a worm-shaft mounted in bearings $b b$, formed on or attached to the machine-frame.

E is a gear-wheel mounted on the front end of the rotative shaft b' in position to engage with the worm-shaft, as shown. A portion of the shaft b' is provided with screw-threads, as shown at b^2 , and is placed in bearings attached to the machine-frame.

F designates a bar, the inner end of which is pivoted to the outer face of the gear-wheel E, and the outer end of this bar is provided with a notch to fit over the bar a^3 near its front end, as shown.

G designates a bar pivoted to the carriage and provided with a threaded notch, c , adapted to fit over and engage with the threaded shaft b' . This pivoted bar is held in position on the threaded shaft by means of the pivoted button c' .

H designates a water-tank attached to the carriage near the wheel C. This tank is provided with a shield, c^2 , extending over the said wheel, and is also provided with a discharge-pipe, c^3 , adapted to convey from the tank a continuous small stream of water upon the grinding-face of the wheel.

The shaft a' , carrying the reducing-wheel, is driven by a belt, d , running over the pulley K on said shaft and the drum K' , mounted on the drive-shaft d' , power being applied to the said drive-shaft by a belt (not shown) running over the pulley K^2 .

The worm-shaft D is driven by a belt, d^3 , running over a pulley, f , mounted on the extended end of the shaft, and over the drum f' , mounted on the extended end of the shaft d' .

L designates a tightening-pulley mounted on a bar, h , having its bearings in the upper ends of the standard h' , the lower ends of which are pivoted upon a bar, h^2 , having its bearings in the standards A' of the machine-frame.

M designates an adjustable table upon which the ends of the saws are placed and clamped in position for fitting them by the reducing-wheel. This table and the devices for adjusting it at the required height and inclination and for clamping the saw in position on the table are all substantially the same in their construction and operation, as fully shown and described in my above-named patent.

It will be seen that the rotary movement of the worm-shaft will rotate the gear-wheel E, and by means of the connecting-bar F will oscillate the shaft a^3 , and the oscillating movement of this shaft will reciprocate longitudinally the shaft a' , causing the reducing-wheel C to travel over the ends of the saw placed under the wheel on the adjustable table, as indicated by dotted lines in Fig. 2 of the drawings, and at the same time the rotary movement of the said gear-wheel rotates the screw-shaft b' , which rotary movement of

the said shaft causes its threaded portion b^2 to engage with the threaded notch in the bar G, thus imparting lateral motion to the carriage B, the direction of the movement of the carriage being reversible by reversing the direction of the rotary movement of the said shaft b' for the purpose of reciprocating the reducing-wheel across the ends of the saws in fitting them perfectly together.

By the construction and combination of the above-named devices it will be seen that the rotary movements of the one worm-shaft D impart the dual reciprocal movements to the reducing-wheel, causing it to travel both longitudinally and transversely over the ends of the saws, thus enabling this machine to shape the said ends speedily and accurately, so that they will fit together perfectly preparatory to brazing them together.

What I claim as new is—

1. In a machine for fitting the ends of a band-saw preparatory to brazing them together, the combination of the wheel C, mounted on the reciprocating shaft a' , having the annular groove a^2 , the bar a^3 , placed in the

annular groove and supported in the oscillating bearings a^4 , the worm-shaft D, the worm-gear E, mounted in position to engage the worm-shaft, and the bar F, pivoted to the gear-wheel and connected with the bar a^3 , substantially as and for the purposes described.

2. In a machine for fitting the ends of a band-saw, the combination of the reciprocating carriage B, the reducing-wheel C, mounted on a shaft, a' , having its bearings on the carriage, the oscillating bar a^3 , connected with the shaft a' , the worm-shaft D, the gear-wheel E, mounted on the threaded shaft b' , the bar F, pivoted to the gear-wheel and connected with the bar a^3 , and the bar G, pivoted to the frame, and having a threaded notch, c , placed over the threaded shaft, substantially as and for the purposes described.

In testimony whereof I have affixed my signature in presence of two witnesses.

JENS MORITZ PETERSEN.

Witnesses:

SCHILLER HOSFORD,
ROBT. J. ARNOLD.