

Sept. 12, 1933.

F. B. LLEWELLYN

1,926,875

MODULATING SYSTEM

Filed Jan. 7, 1932

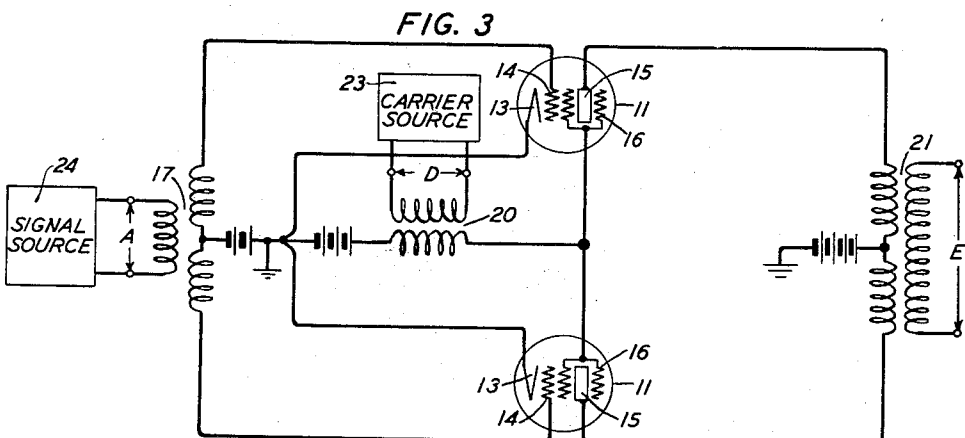
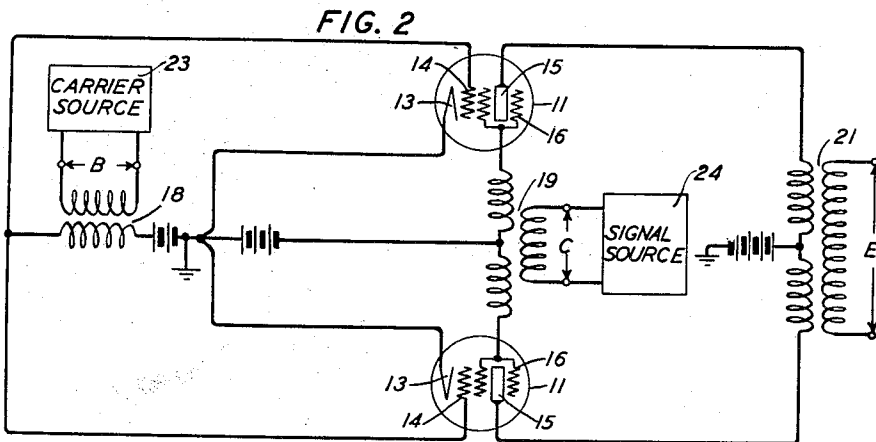
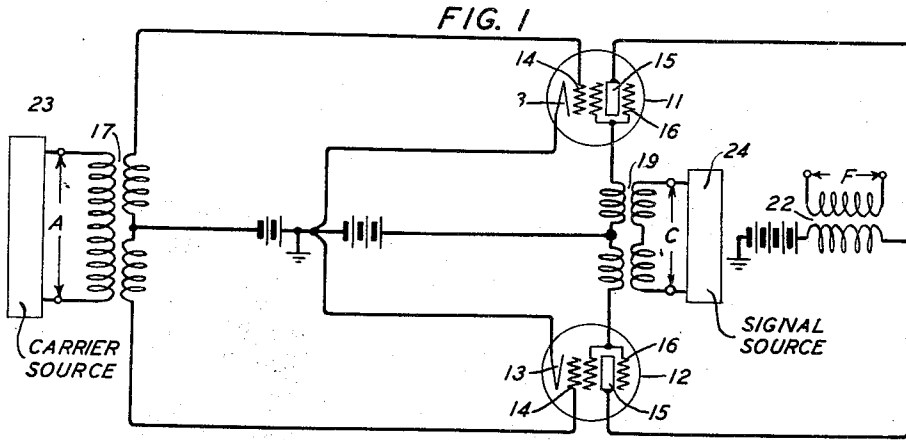

INVENTOR
F. B. LLEWELLYN
BY *G. A. Stevenson*
ATTORNEY

UNITED STATES PATENT OFFICE

1,926,875

MODULATING SYSTEM

Frederick B. Llewellyn, Montclair, N. J., assignor
to Bell Telephone Laboratories, Incorporated,
New York, N. Y., a corporation of New York

Application January 7, 1932. Serial No. 535,186

2 Claims. (Cl. 179—171)

This invention relates to modulating systems of the space discharge type, and more particularly to modulators in which the carrier wave is balanced out or suppressed.

5 Heretofore balanced modulators have been employed extensively in systems using frequencies which are relatively low, for example, up to 50,000 cycles per second but to a much less extent at higher frequencies. In the use of such modulators at the frequencies common in radio communication systems including both long wave and short wave systems, difficulty is encountered in meeting certain requirements easily satisfied at the lower frequencies. One such requirement is that the carrier wave be supplied through a circuit which can be adjusted substantially independently of the output circuit which transmits the modulated wave. It is essential that both the frequency and amplitude of the carrier wave
10 supplied to the modulator be maintained very constant and this adjustment should not be disturbed by any adjustments or variations which may take place in the output circuit. At high frequencies, it is desirable that there should be a complete segregation of the respective circuits, which are provided for the carrier wave, the modulating current and the modulated output. It is further desirable in most cases to conserve the energy of the modulating current by preventing undue absorption of energy from the modulating current when it is applied to the modulator.

In accordance with the present invention, a balanced modulator is provided, comprising two electric discharge tubes, each of which contains in addition to the cathode, the anode and a control grid, a fourth electrode constituting a screen grid which shields the anode from the control grid. The screen grid serves at the same time as a second control grid to which one of the input waves may be applied.

The invention is described in detail hereinafter in connection with the accompanying drawing in which:

45 Figs. 1, 2 and 3 represent schematically several balanced modulator circuits embodying the invention.

Referring to Fig. 1, two electric discharge tubes 11 and 12 are connected in a symmetrical or balanced arrangement. Each tube contains a cathode 13, a control grid 14, an anode 15, and a screen grid 16 adapted to electrostatically shield the anode 15 from the control grid 14. The cathode 13 is assumed to be activated in any suitable manner. The control grid is negatively polarized

while the screen grid and plate are positively polarized.

A carrier source 23 is connected to the primary terminals A of a three-winding transformer 17, which is adapted to couple the source to the two control grids 14, 14 in opposite phase. A signal source 24 is connected to the primary terminals C of a second three-winding transformer 19 adapted to couple the signal source to the screen grids 16, 16 in opposite phase. A two-winding transformer 22 is arranged to respond to the sum of the plate currents of the two tubes, the summation current being made available at the pair of terminals F. Due to the balanced arrangement of the circuits the carrier is suppressed at F, while modulation products or sidebands are delivered to these terminals.

Fig. 2 shows a second balanced modulating system in which the carrier source 23 is connected at B to the input terminals of a two-winding transformer 18 which is adapted for coupling to the control grids 14, 14 in like phase. The signal source 24 is applied at C through the transformer 19 to the screen grids 16, 16 in opposite phase. The modulated output is available at E from a transformer 21 and due to the balanced arrangement the unmodulated carrier is suppressed in the output circuit. The carrier source and the output circuit are substantially isolated from each other by the screening effects of the screen grid tubes. In this arrangement the screen grid is negatively polarized while the control grid is positively polarized.

Fig. 3 shows still another arrangement, in which the signal source is applied at A to excite the control grids in opposite phase and the carrier source is applied at D through a transformer 20, to the screen grids in like phase. As in the circuit of Fig. 2 the carrier is suppressed in the output circuit at E. The control grids are preferably negatively polarized in order to prevent undue absorption of the signal currents.

Analogous arrangements employing three-element discharge devices are shown in U. S. Patent 1,463,795, issued August 7, 1923 to J. R. Carson, but in the system of the present invention it is not necessary to superimpose the input and output circuits upon a single pair of tube elements, there being available the additional circuit employing the pair of screen grids. Separate circuits are thus provided for the carrier input, the signal input and the modulated output, respectively. The plate circuits are also substantially isolated from the control grid circuits by the screen grids interposed between. Accordingly,

the circuits of terminals A and B are capable of adjustment without affecting the circuits E and F, and vice versa. The degree of independence between the screen grid circuits and the plate
 5 circuits is somewhat less than between the control grids and the plates but is nevertheless fairly satisfactory. The screen grid circuits are also independent of the control grid circuits to a large extent.

10 The arrangement of polarizing potentials shown in Fig. 2 is advantageous when the signal source is to be connected to the screen grids. In order to prevent excessive loss due to absorption of signal currents in the screen grid circuit
 15 the impedance of that circuit is increased by negatively polarizing the screen grid. When this is done it is necessary to polarize the control grid positively in order to neutralize the effect of the space charge in the neighborhood of the cathode
 20 and prevent blocking of the tube.

What is claimed is:

1. A modulating system comprising a space discharge tube having a cathode, an anode, a control grid and a screen grid, a source of carrier waves and an output circuit connected to the control grid and the anode, respectively, to secure substantial isolation of said source from said output circuit by virtue of the screening

effect of the screen grid, a source of modulating currents in circuit with the screen grid, said screen grid being negatively polarized to substantially prevent absorption of modulating currents in said tube, and a source of positive polarizing potential connected to the control grid to offset the blocking effect of space charge in the neighborhood of the cathode.

2. A balanced modulating system of the suppressed carrier type comprising a pair of electric discharge tubes, each including a cathode, an anode, a control grid and a screen grid, means for impressing a negative biasing potential upon the screen grids, a source of modulating voltage, means for connecting said source in opposite phase relation to the respective screen grids, means for impressing a positive biasing potential upon the control grids to counteract the effect of space charge in the neighborhood of the cathodes, a source of carrier waves, means for connecting said carrier wave source in like phase relation to the respective control grids, and a divided output circuit connected to the anodes, said output circuit being substantially prevented from reacting upon said control grids by the screening effect of said screen grids.

FREDERICK B. LLEWELLYN.

30	105
35	110
40	115
45	120
50	125
55	130
60	135
65	140
70	145
75	150