



(51) International Patent Classification:

A61M 5/30 (2006.01) A61M 5/31 (2006.01)
A61M 5/28 (2006.01)

(21) International Application Number:

PCT/IL20 14/050405

(22) International Filing Date:

5 May 2014 (05.05.2014)

(25) Filing Language:

English

(26) Publication Language:

English

(30) Priority Data:

61/821,760 10 May 2013 (10.05.2013) US

(71) Applicant: **MEDIMOP MEDICAL PROJECTS LTD** [IL/IL]; 17 Hatidhar Street, POBox 2499, 43665 Ra'anana (IL).

(72) Inventors: **MARKS, Hugh Zachary**; 18 Debarry Place, Summit, New Jersey 07901 (US). **LEV, Nimrod**; 1 Havradim Street, 56905 Savion (IL). **LEV, Amir**; 1/1 Frierberg Street, 44347 Kfar Saba (IL).

(81) Designated States (unless otherwise indicated, for every kind of national protection available): AE, AG, AL, AM, AO, AT, AU, AZ, BA, BB, BG, BH, BN, BR, BW, BY,

BZ, CA, CH, CL, CN, CO, CR, CU, CZ, DE, DK, DM, DO, DZ, EC, EE, EG, ES, FI, GB, GD, GE, GH, GM, GT, HN, HR, HU, ID, IL, IN, IR, IS, JP, KE, KG, KN, KP, KR, KZ, LA, LC, LK, LR, LS, LT, LU, LY, MA, MD, ME, MG, MK, MN, MW, MX, MY, MZ, NA, NG, NI, NO, NZ, OM, PA, PE, PG, PH, PL, PT, QA, RO, RS, RU, RW, SA, SC, SD, SE, SG, SK, SL, SM, ST, SV, SY, TH, TJ, TM, TN, TR, TT, TZ, UA, UG, US, UZ, VC, VN, ZA, ZM, ZW.

(84) Designated States (unless otherwise indicated, for every kind of regional protection available): ARIPO (BW, GH, GM, KE, LR, LS, MW, MZ, NA, RW, SD, SL, SZ, TZ, UG, ZM, ZW), Eurasian (AM, AZ, BY, KG, KZ, RU, TJ, TM), European (AL, AT, BE, BG, CH, CY, CZ, DE, DK, EE, ES, FI, FR, GB, GR, HR, HU, IE, IS, IT, LT, LU, LV, MC, MK, MT, NL, NO, PL, PT, RO, RS, SE, SI, SK, SM, TR), OAPI (BF, BJ, CF, CG, CI, CM, GA, GN, GQ, GW, KM, ML, MR, NE, SN, TD, TG).

Published:

- with international search report (Art. 21(3))
- before the expiration of the time limit for amending the claims and to be republished in the event of receipt of amendments (Rule 48.2(h))



WO 2014/181328 A1

(54) Title: MEDICAL DEVICES INCLUDING VIAL ADAPTER WITH INLINE DRY DRUG MODULE

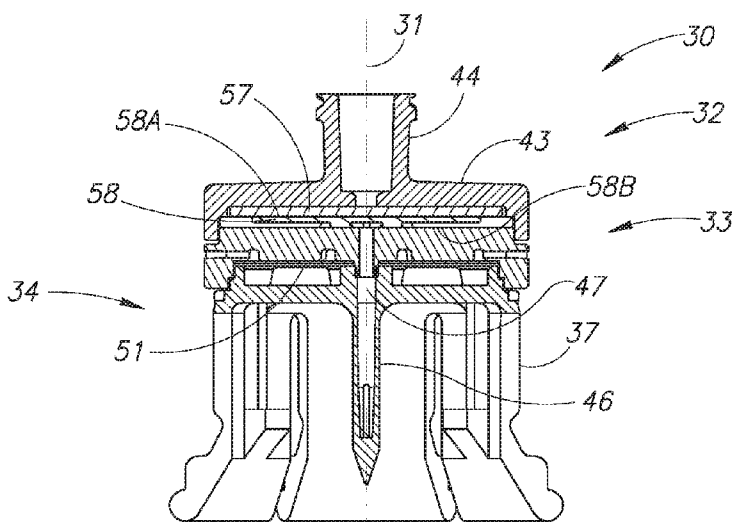

FIG.4

(57) Abstract: Medical devices including a vial adapter (32) with an inline dry drug module (33) for use with a vial (20), a needleless syringe (10) and a carrier liquid (26) for filling the needleless syringe with an injection solution for injection to a patient. The inline dry drug modules (33) include a dry drug storage component (57) for storing a dry drug dosage and a uniform carrier liquid distribution component (58) for promoting uniform contact of the dry drug storage component by the carrier liquid to form an injection solution from the dry drug dosage. The inline dry drug modules can include a discrete dry drug storage component and a discrete uniform carrier liquid distribution component or a dual purpose component for both drug storage and uniform carrier liquid distribution. The vial adapters can be provided in vented or non-vented versions.

MEDICAL DEVICES INCLUDING VIAL ADAPTER WITH INLINE DRY DRUG MODULE

Field of the Invention

The invention pertains to medical devices with an inline dry drug module
5 including a dry drug dosage for use with a liquid source for parenteral
administration to a patient.

Background of the Invention

Medical treatments often involve parenteral administration of liquid drugs
10 to the human body. The liquid drugs can be in the form of solutions,
suspensions, and the like. Some drugs reagents have extended shelf-lives in a
dry state and only short shelf-lives after reconstitution or rehydration.

US Patent No. 6,520,932 to Taylor discloses an inline drug delivery pack
(35) that connects inline with an intravenous (IV) line and allows for the mixing
15 of diluent with a drug reagent to be delivered to a patient. The drug delivery
pack includes a housing (37) with a reagent bed (110) consisting of a fluid
soluble material suitable to administration to a patient via dissolution and IV
drip. The housing includes inlet radial fins (65) which cooperate with back
pressure from an inlet frit (80) to promote a uniform distribution of diluent across
20 the entire cross section of the drug delivery pack. An internal drug bed bypass
mechanism is tailored to apportion diluent flow between the bypass and the drug
bed to achieve a solution concentration suitable for IV administration as the dried
reagent is dissolved.

US Patent No. 6,951,613 to Reif et al. discloses a genetic vaccination
25 device and a process for forming an injection solution therefor. The device
includes a syringe (2) and a cannula (3) coupled to an inline membrane adsorber
(5) having genetic material adsorbed thereon. The process includes eluting the

genetic material from the membrane adsorber so as to form an injection solution containing the genetic material.

US Patent Application Publication No. US 2008/0294100 to de Costa et al. discloses a pharmaceutical device for the administration of substrates to a patient. The de Costa pharmaceutical device is similar to the aforementioned Reif genetic vaccination device insofar it includes an inline porous membrane supporting a glassy material soluble in water and having biological materials such as vaccines stabilized thereon such that when the biological material requires administration, eluent can be passed across the membrane dissolving the glass and causing the substance to be carried by the liquid into a patient.

The Reif genetic vaccination device and the de Costa pharmaceutical device are relatively heavy and cumbersome to handle during injection of an injection solution to a patient. Furthermore, their device housings containing the dry drug dosage to be injected to a patient necessarily impose injections at larger injection angles to a patient's body than is customary.

There is a need for medical devices with an inline dry drug module for facilitating injecting an injection solution to a patient.

Summary of the Invention

The present invention is directed toward medical devices including a vial adapter with an inline dry drug module having a dry drug dosage for use with a needleless syringe and a vial for filling the needleless syringe with an injection solution formed from the dry drug dosage for injection to a patient. The medical devices are preferably used with an initially empty needleless syringe and a vial initially filled with a liquid carrier. Alternatively, the medical device can be used with a syringe initially pre-filled with a liquid carrier and an initially empty vial. The liquid carrier can be diluent only or alternatively can include an active component.

The vial adapters have a similar construction as commercially available vented or non-vented vial adapters except for the inline dry drug modules. The inline dry drug modules include a dry drug storage component for storing a dry drug dosage and a uniform carrier liquid distribution component for promoting
5 uniform contact of the dry drug storage component by the carrier liquid to form the injection solution. The dry drug storage component and the uniform carrier liquid distribution component can be two discrete components. Alternatively, the two components can be combined in a single dual purpose component.

The inline dry drug modules can employ any one of several commercially
10 available technologies for enabling long term storage of a dry drug dosage for subsequent forming into an injection solution on contact by a carrier liquid. Suitable commercially available technologies are inter alia discussed in the prior art references acknowledged in the Background of the Invention. The different technologies include inter alia flowing carrier liquid through a porous substrate
15 to dissolve or entrain a dry drug dosage, flowing carrier liquid on a substrate surface to dissolve or entrain a dry drug dosage, and the like.

The use of medical devices of the present invention with an initially empty needleless syringe and an initially filled vial involves a single aspiration. Alternatively, the use of the medical devices of the present invention with an
20 initially filled syringe and an initially empty vial requires an initial injection of a carrier liquid from the syringe to the vial and a subsequent aspiration from the vial to the syringe. The former use takes less time whilst the latter use can afford greater certainty regarding complete usage of a dry drug dosage.

The medical devices of the present invention afford a convenient low cost
25 solution for the preparation of needleless syringes for injection of injection solutions to patients. The medical devices of the present invention are particularly suitable for use with so-called thermo-stable drugs and reagents which have a relatively long shelf-life at ambient temperatures thereby negating

the need for refrigeration. Suitable drugs and reagents include inter alia vaccines, and the like.

Brief Description of the Drawings

In order to understand the invention and to see how it can be carried out in practice, preferred embodiments will now be described, by way of non-limiting examples only, with reference to the accompanying drawings, in which similar parts are likewise numbered, and in which:

Fig. 1 is a pictorial view of an initially empty needleless syringe, a vial, and a first embodiment of a vented medical device in accordance with the present invention for filling the initially empty needleless syringe with an injection solution;

Fig. 2 is a bottom perspective view of the Figure 1 medical device;

Fig. 3 is a side elevation view of the Figure 1 medical device;

Fig. 4 is a longitudinal cross section of the Figure 1 medical device along line A-A in Figure 3;

Fig. 5 is an exploded view of the Figure 1 medical device;

Fig. 6 is a bottom perspective view of a uniform carrier liquid distribution component of the Figure 1 medical device;

Fig. 7A shows an inverted assemblage of the initially empty needleless syringe, the Figure 1 medical device and the vial prior to aspiration of carrier liquid from the vial to the needleless syringe;

Fig. 7B shows the inverted assemblage subsequent to partial aspiration of carrier liquid from the vial to the needleless syringe;

Fig. 7C shows the inverted assemblage with the needleless syringe filled with injection solution for administration to a patient;

Fig. 8 is a close up longitudinal cross section of the encircled section of Figure 7B's assemblage showing the flow of carrier liquid from the vial to the syringe during aspiration;

Fig. 9 is an exploded view of a second embodiment of a vented medical device in accordance with the present invention; and

Fig. 10 is a bottom perspective view of a uniform carrier liquid distribution component of the Figure 9 medical device.

5

Detailed Description of the Drawings

Figure 1 shows an empty needleless syringe 10, a vial 20 and a vented medical device 30 for use for filling the needleless syringe 10 with an injection solution for injection to a patient. The syringe 10 includes a barrel 11 with a plunger rod 12 and a syringe tip 13. The vial 20 includes a vial bottle 21 sealed by a vial stopper 22. The vial bottle 21 typically includes an aluminum seal 23 for securing the vial stopper 22 on the vial bottle 21. The vial bottle 21 has a vial interior 24 containing a carrier liquid 26. The carrier liquid 26 can be diluent only. Alternatively, the carrier liquid 26 can include an active component.

15 Figures 1 to 6 show the medical device 30 has a longitudinal device centerline 31 and includes a vial adapter 32 with an inline dry drug module 33. The vial adapter 32 includes a skirt 34 having a transverse top skirt wall 36 and downward depending flex members 37 for telescopic mounting onto the vial 20. The top skirt wall 36 is formed with a central skirt hub 38 co-axial with the longitudinal device axis 31 with six equispaced radial ribs 39 outwardly extending therefrom. The central skirt hub 38 is formed with a liquid transfer port 41 co-axial with the longitudinal device axis 31 and a vent port 42 offset with respect to the longitudinal device axis 31.

25 The vial adapter 32 includes a top cover 43 having a central upright female connector 44 co-axial with the longitudinal device centerline 31 for sealing connection with the syringe tip 13. The syringe tip 13 is preferably a male Luer lock connector and the central upright female connector 44 is a female Luer connector for screw thread mounting of the needleless syringe 10 on the

medical device 30. Alternatively, the syringe tip 13 and the female connector 44 can be formed with other connectors.

The vial adapter 32 includes a downward depending puncturing cannula 46 co-axial with the longitudinal device 31 for puncturing the vial stopper 22 for flow communication with the vial interior 24 on telescopic mounting the medical device 30 on the vial 20. The cannula 46 includes a liquid transfer lumen 47 in flow communication with the liquid transfer port 41 and a vent lumen 48 in flow communication with the vent port 42.

The vial adapter 32 includes a filter cover 49 for deployment between the top cover 43 and the top skirt wall 36. The filter cover 49 encloses an air filter 51 placed on the radial ribs 39. The air filter 51 has a central air filter aperture 52 co-axial with the longitudinal device axis 31. The filter cover 49 includes a central filter cover aperture 53 co-axial with the longitudinal device axis 31 and a peripheral filter cover edge 54 formed with a multitude of vent apertures 56.

The inline dry drug module 33 is disposed inline between the central upright female connector 44 and the puncturing cannula 46 and in particular the liquid transfer port 41. The inline dry drug module 33 includes a dry drug storage component 57 proximate the upright female connector 44 and distal from the puncturing cannula 46. The inline dry drug module 33 further includes a uniform carrier liquid distribution component 58 proximate the puncturing cannula 46 and distal from the upright female connector 44.

The dry drug storage component 57 is preferably formed as a disc-like substrate formed from a wide range of suitable bio-compatible inert porous materials enabling carrier liquid 26 to flow therethrough. Suitable materials include inter alia glass fiber, plastic fiber, and the like. The dry drug storage component 57 is provisioned with a dry drug dosage 59 for administration to a patient. The dry drug dosage 59 can be in the form of very fine particles, and the like, for enabling reconstitution of an injection solution on entraining carrier liquid 26 through the dry drug storage component 57.

The uniform carrier liquid distribution component 58 is preferably formed as a disc-like member having a uniform carrier liquid distribution component topside 58A facing the upright female connector 44, a uniform carrier liquid distribution component underside 58B facing the puncturing cannula 46, and a uniform carrier liquid distribution component peripheral edge 61. The uniform carrier distribution component underside 58B is formed with a series of radial grooves 62 each terminating at a cutout 63 in the uniform carrier liquid distribution component peripheral edge 61 for enabling flow communication from the uniform carrier liquid distribution component underside 58B to the uniform carrier liquid distribution component topside 58A.

The use of the medical device 30 for use in the preparation of the needleless syringe 10 with an injection solution for injection to a subject is now described with reference to Figures 7A to 7C and Figure 8 which is an enlargement of the encircled area denoted A in Figure 7B :

Figure 7A shows a user telescopically mounts the medical device 30 onto the vial 20 to puncture the vial stopper 22. The user connects the needleless syringe 10 to the female connector 44. The user inverts the assemblage such that the vial 20 is above the needleless syringe 10 and begins to aspirate the carrier liquid 26 from the vial 20 into the needleless syringe 10.

Figure 7B and Figure 8 show the flow of carrier liquid 26 from the vial 20 to the initially empty needleless syringe 10 as follows: The carrier liquid 26 flows downward along the liquid transfer lumen 47 to the uniform carrier liquid distribution component underside 58B. The carrier liquid 26 flows radial outward from the center of the uniform carrier liquid distribution component underside 58B along the radial grooves 62 to the uniform carrier liquid distribution component peripheral edge 61.

The carrier liquid 26 flows downward through the cutouts 63 and then radial inwards through the porous dry drug storage component 57 to entrain the dry drug dosage 59 therewith to form an injection solution 64. During aspiration

of the carrier liquid 26 from the vial 20 to the syringe 10, air is drawn through the vent apertures 56, the air filter 51 and the vent lumen 48 into the vial 20 as indicated by air bubbles in the carrier liquid 26.

Figure 7C shows the syringe 10 filled with an injection solution 64 ready
5 for injection to a subject after disconnection from the female connector 44 and attachment of a needle.

Figure 9 shows a vented medical device 70 similar in construction and operation as the vented medical device 30 and therefore similar parts are likewise numbered. The latter 70 differs from the former 30 insofar its inline dry drug
10 module 33 includes a single dual purpose component 71 acting as both a dry drug dosage storage component and a uniform carrier liquid distribution component. The dual purpose component 71 has a similar construction as the uniform carrier liquid distribution component 58 insofar as it includes a uniform carrier liquid distribution component topside 71A facing the female connector 44, a uniform
15 carrier liquid distribution component underside 71B facing the puncturing cannula 46 and a uniform carrier liquid distribution component peripheral edge 72. The uniform carrier liquid distribution component topside 71A has a dry drug dosage coating 73 constituting a dry drug dosage storage component. The uniform carrier distribution component underside 71B is formed with a series of
20 radial grooves 62 each terminating at a cutout 63 in the uniform carrier liquid distribution component peripheral edge 72 for enabling flow communication from the uniform carrier liquid distribution component underside 71B to the uniform carrier liquid distribution component topside 71A.

25 While the invention has been described with respect to a limited number of embodiments, it will be appreciated that many variations, modifications, and other applications of the invention can be made within the scope of the appended claims.

Claims

1. A medical device for use with a needleless syringe, a vial and a carrier liquid for filling the needleless syringe with an injection solution for injection to a patient, the needleless syringe having a male connector, the vial having a vial stopper and a vial interior, the medical device having a longitudinal device centerline and comprising:
- 5
- (a) a vial adapter having a skirt with downward depending flex members for telescopic mounting on the vial, a puncturing cannula for puncturing the vial stopper on said telescopic mounting for flow communication with the vial interior and a central upright female connector in flow communication with said puncturing cannula and intended for connection to the male connector; and
- 10
- (b) an inline dry drug module disposed inline between said female connector and said puncturing cannula, said inline dry drug module including a dry drug storage component for storing a dry drug dosage and a uniform carrier liquid distribution component for promoting uniform contact of said dry drug storage component by said carrier liquid on aspiration of carrier liquid from the vial to the needleless syringe to form the injection solution.
- 15
2. The device according to claim 1 wherein said inline dry drug module includes a discrete dry drug storage component for storing said dry drug dosage and a discrete uniform carrier liquid distribution component for promoting said uniform contact.
- 20
3. The device according to claim 1 wherein said inline dry drug module includes a dual purpose component for both storing said dry drug dosage and promoting said uniform contact.
- 25
4. The device according to any one of claims 1 to 3 wherein said uniform carrier liquid component includes a uniform carrier liquid component topside

facing said female connector, a uniform carrier liquid distribution component underside facing said puncturing cannula and a uniform carrier liquid distribution component peripheral edge,

5 said uniform carrier liquid distribution component underside having a multitude of radial grooves each terminating in a cutout in said uniform carrier liquid distribution component peripheral edge thereby enabling carrier liquid to flow from said uniform carrier liquid distribution component underside to said uniform carrier liquid distribution component topside on aspiration of the needleless syringe to draw liquid contents from the vial to the needleless syringe.

1/6

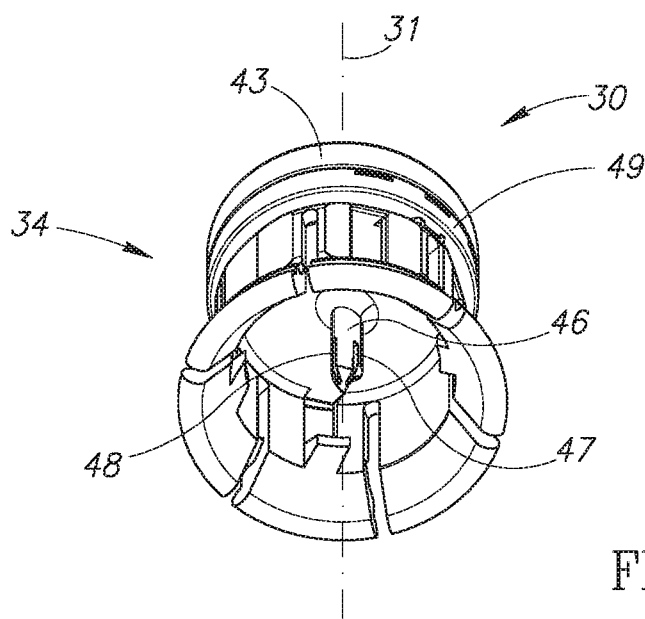
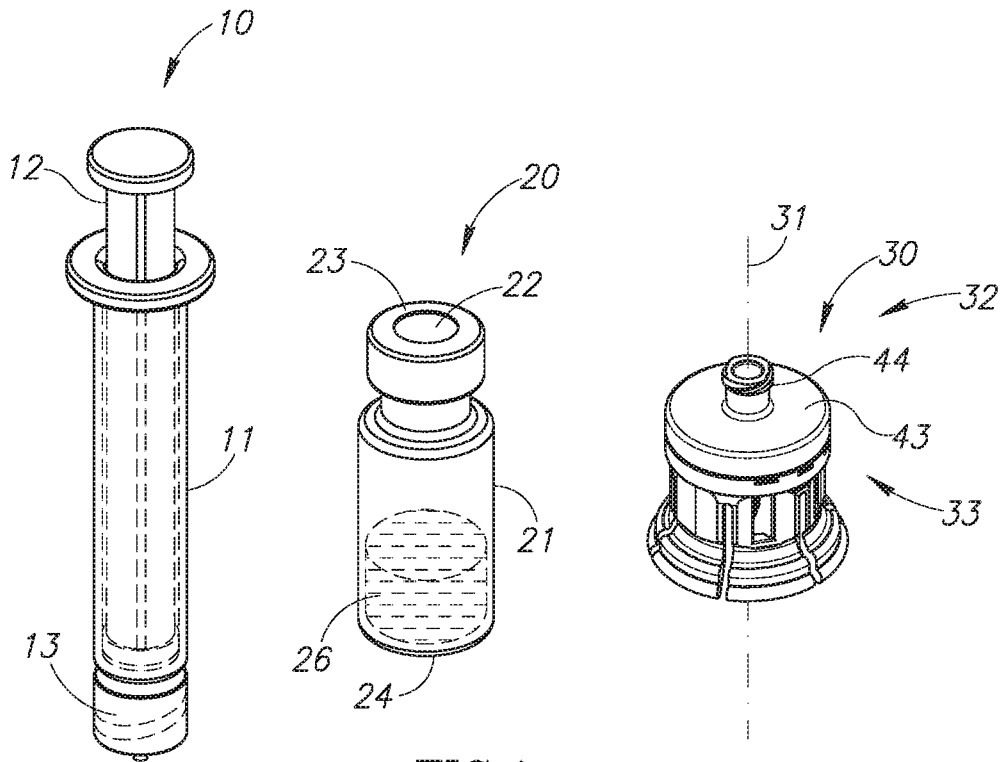

2/6

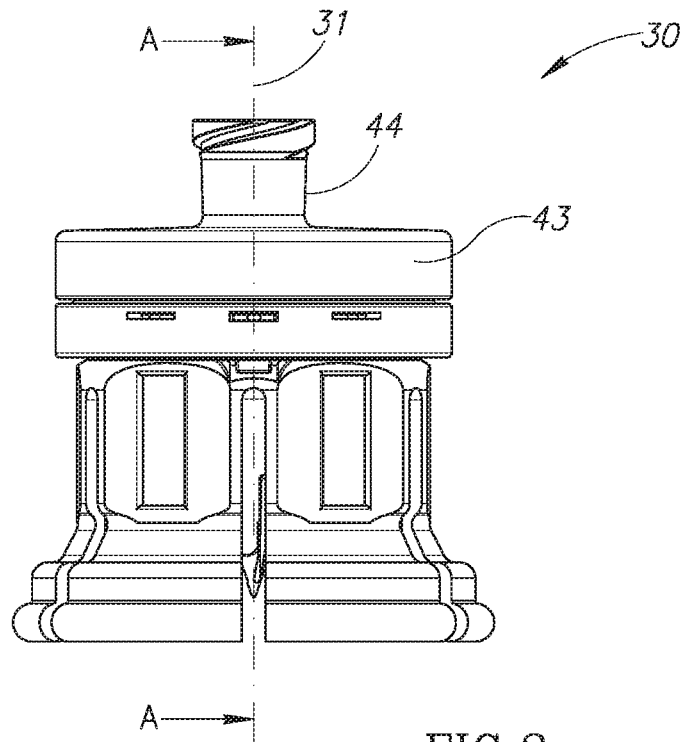

FIG. 3

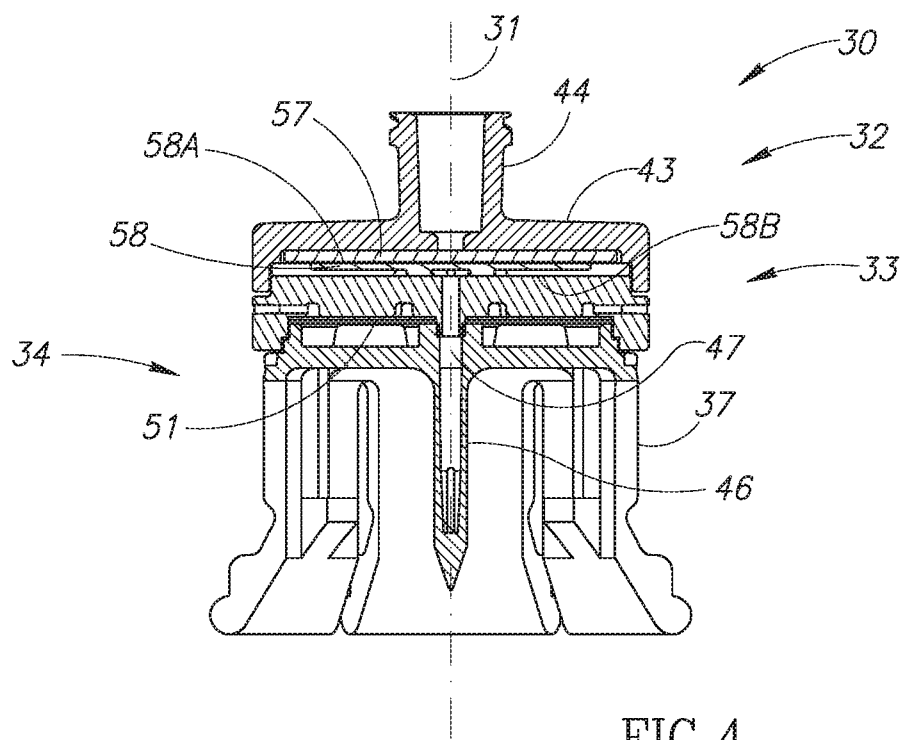

FIG. 4

3/6

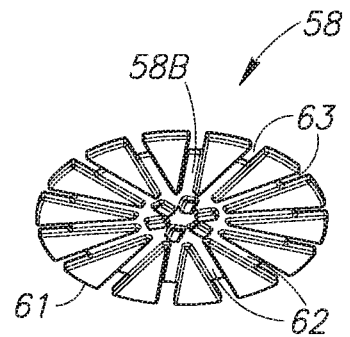
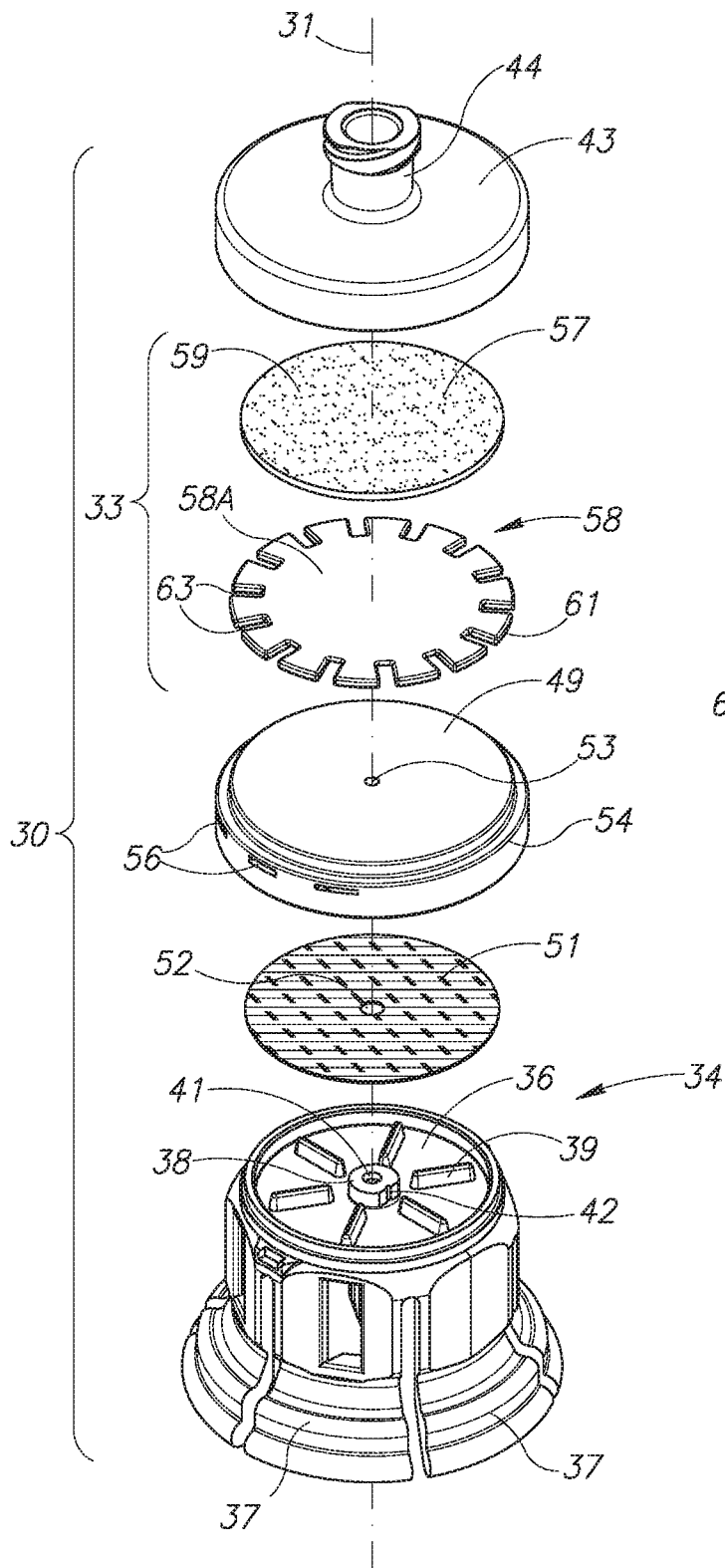

FIG. 6

FIG. 5

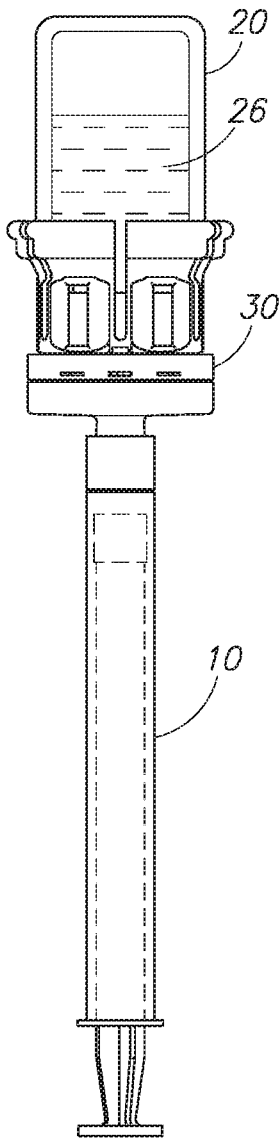

FIG. 7A

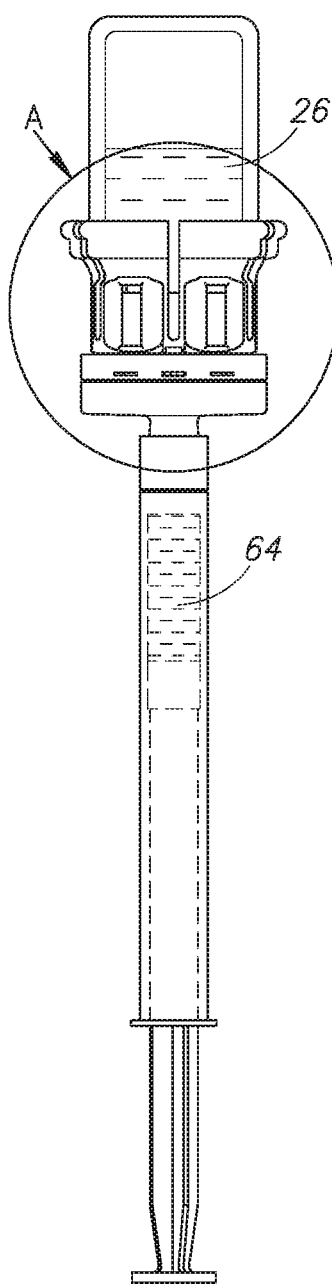

FIG. 7B

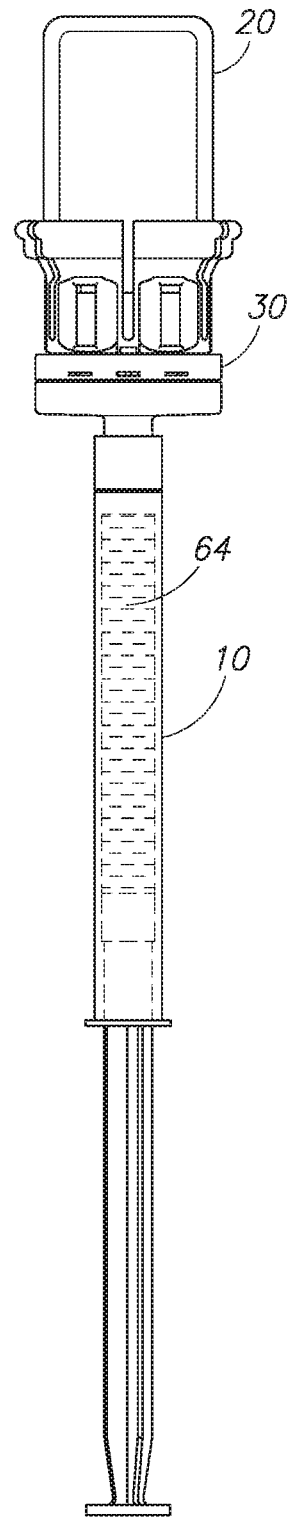

FIG. 7C

5/6

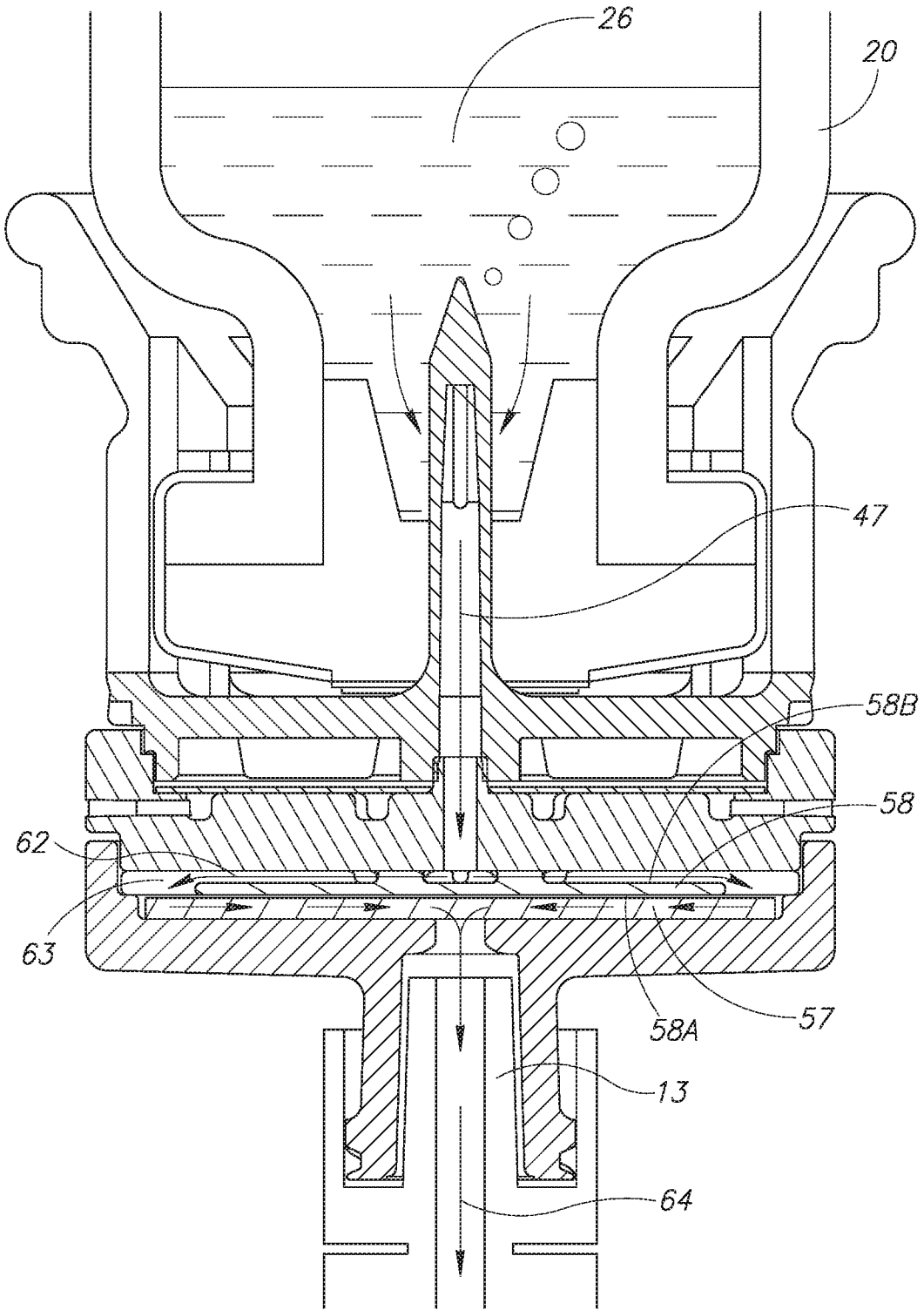

FIG. 8

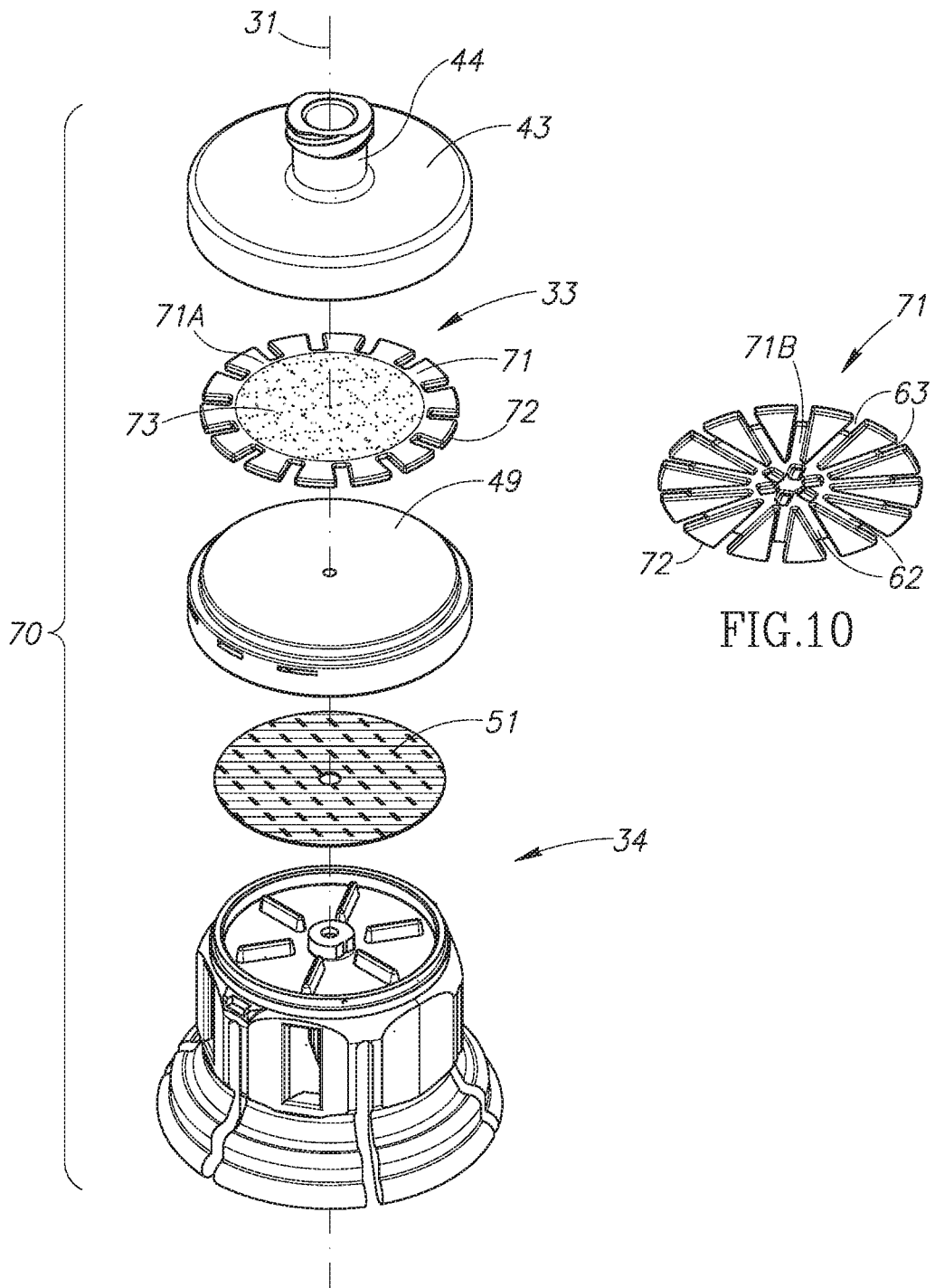

FIG. 9

FIG. 10

INTERNATIONAL SEARCH REPORT

| |
|--|
| International application No PCT/IL2014/050405 |
|--|

A. CLASSIFICATION OF SUBJECT MATTER
INV. A61M5/30 A61M5/28 A61M5/31
ADD.

According to International Patent Classification (IPC) or to both national classification and IPC

B. FIELDS SEARCHED

Minimum documentation searched (classification system followed by classification symbols)
A61M

Documentation searched other than minimum documentation to the extent that such documents are included in the fields searched

Electronic data base consulted during the international search (name of data base and, where practicable, search terms used)
EPO-Internal , WPI Data

C. DOCUMENTS CONSIDERED TO BE RELEVANT

| Category* | Citation of document, with indication, where appropriate, of the relevant passages | Relevant to claim No. |
|-----------|---|-----------------------|
| X | wo 2007/101772 AI (NOVO NORDISK AS [DK] ; RADMER BO [DK] ; MOELLER CLAUS [DK] ; KLOK LOUISE) 13 September 2007 (2007-09-13) abstract claim 1 figures 1,4 | 1-4 |
| X | ----- EP 1 911 432 AI (NOVO NORDISK AS [DK]) 16 April 2008 (2008-04-16) abstract figures | 1-4 |
| A | ----- US 4 871 463 A (TAYLOR MICHAEL A [US] ET AL) 3 October 1989 (1989-10-03) abstract claims figures ----- | 1-4 |

Further documents are listed in the continuation of Box C. See patent family annex.

* Special categories of cited documents :

| | |
|---|---|
| <p>"A" document defining the general state of the art which is not considered to be of particular relevance</p> <p>"E" earlier application or patent but published on or after the international filing date</p> <p>"L" document which may throw doubts on priority claim(s) or which is cited to establish the publication date of another citation or other special reason (as specified)</p> <p>"O" document referring to an oral disclosure, use, exhibition or other means</p> <p>"P" document published prior to the international filing date but later than the priority date claimed</p> | <p>"T" later document published after the international filing date or priority date and not in conflict with the application but cited to understand the principle or theory underlying the invention</p> <p>"X" document of particular relevance; the claimed invention cannot be considered novel or cannot be considered to involve an inventive step when the document is taken alone</p> <p>"Y" document of particular relevance; the claimed invention cannot be considered to involve an inventive step when the document is combined with one or more other such documents, such combination being obvious to a person skilled in the art</p> <p>"&" document member of the same patent family</p> |
|---|---|

| | |
|---|---|
| Date of the actual completion of the international search 8 August 2014 | Date of mailing of the international search report 02/09/2014 |
|---|---|

| | |
|--|--|
| Name and mailing address of the ISA/ European Patent Office, P.B. 5818 Patentlaan 2 NL - 2280 HV Rijswijk Tel. (+31-70) 340-2040, Fax: (+31-70) 340-3016 | Authorized officer Turkavci , Levent |
|--|--|

INTERNATIONAL SEARCH REPORT

Information on patent family members

International application No

PCT/IL2014/050405

| Patent document cited in search report | Publication date | Patent family member(s) | Publication date |
|--|------------------|-------------------------|---------------------------|
| WO 2007101772 | A1 | 13-09-2007 | NONE |
| ----- | | | |
| EP 1911432 | A1 | 16-04-2008 | NONE |
| ----- | | | |
| US 4871463 | A | 03-10-1989 | CA 1324877 C 07-12-1993 |
| | | | EP 0446213 A1 18-09-1991 |
| | | | JP 3190657 B2 23-07-2001 |
| | | | JP H04503628 A 02-07-1992 |
| | | | US 4871463 A 03-10-1989 |
| | | | WO 9104792 A1 18-04-1991 |
| ----- | | | |