

(No Model.)

3 Sheets—Sheet 1.

R. D. PATTERSON.
ELECTRIC TIME SIGNAL FOR RAILWAYS.

No. 525,277.

Patented Aug. 28, 1894.

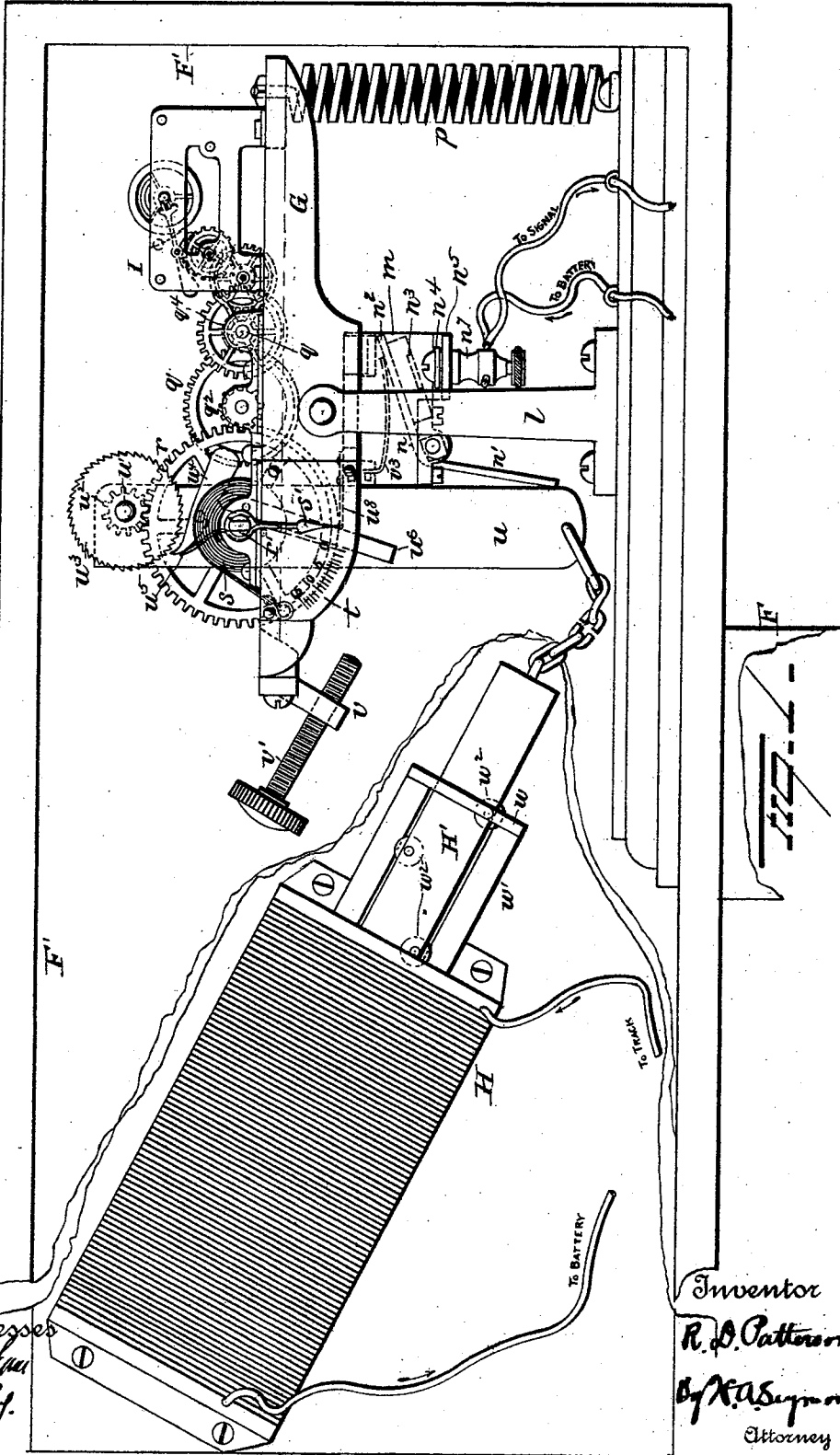

Witnesses
R. D. Patterson
G. J. Johnson

Inventor
R. D. Patterson
By H. A. Seymour
Attorney

(No Model.)

3 Sheets—Sheet 2.

R. D. PATTERSON.
ELECTRIC TIME SIGNAL FOR RAILWAYS.

No. 525,277.

Patented Aug. 28, 1894.

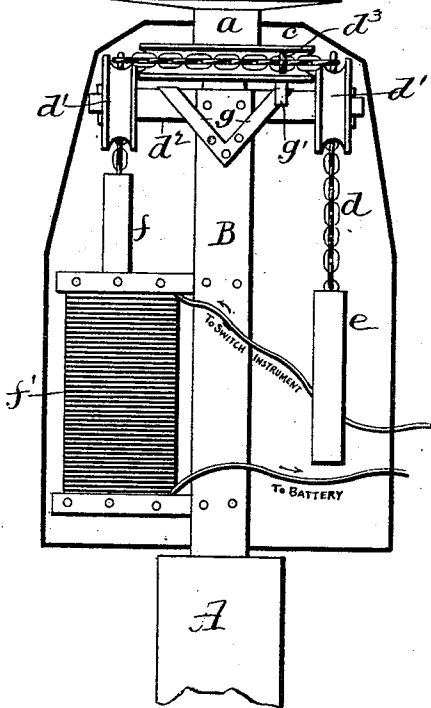
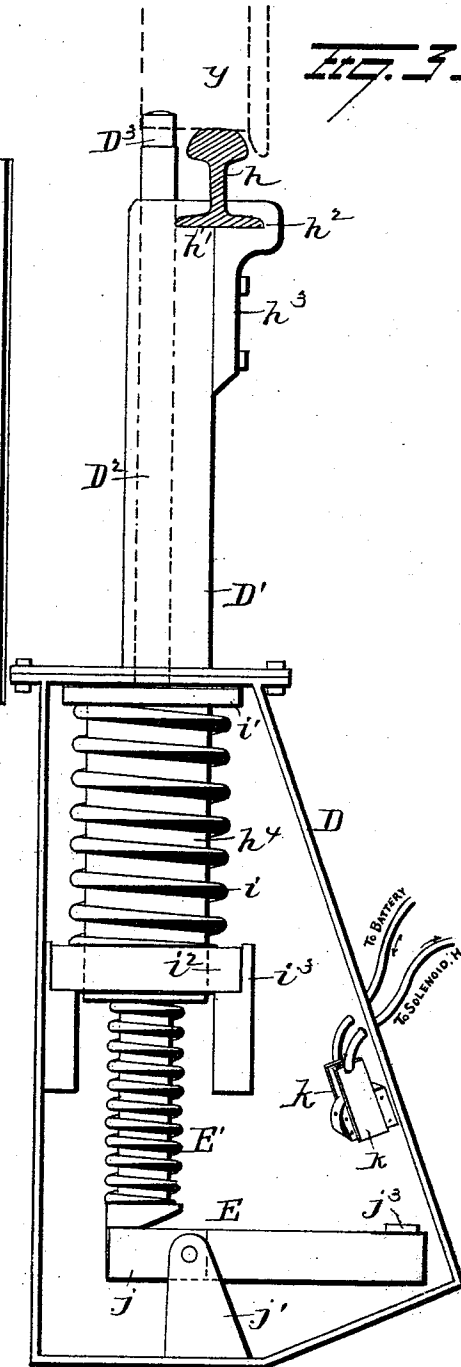
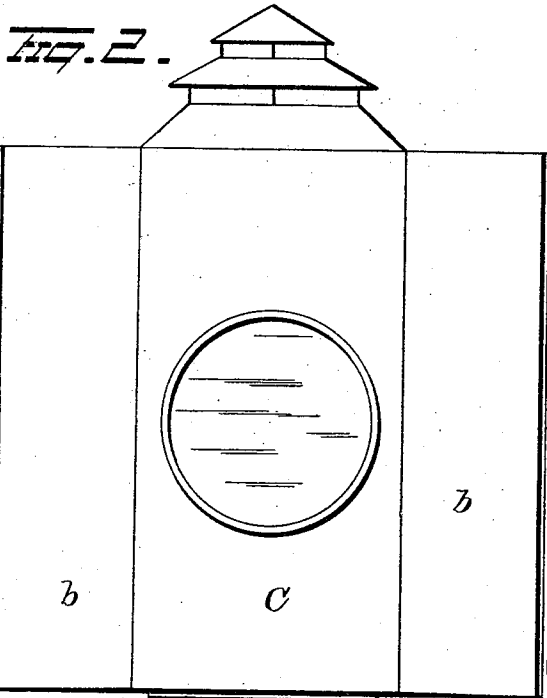

Witnesses
P. S. Tottenham
G. F. Downing

Inventor
R. D. Patterson
 By *H. A. Seymour*
 Attorney

(No Model.)

3 Sheets—Sheet 3.

R. D. PATTERSON.
ELECTRIC TIME SIGNAL FOR RAILWAYS.

No. 525,277.

Patented Aug. 28, 1894.

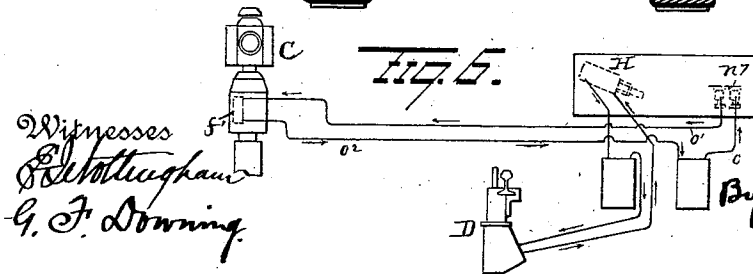
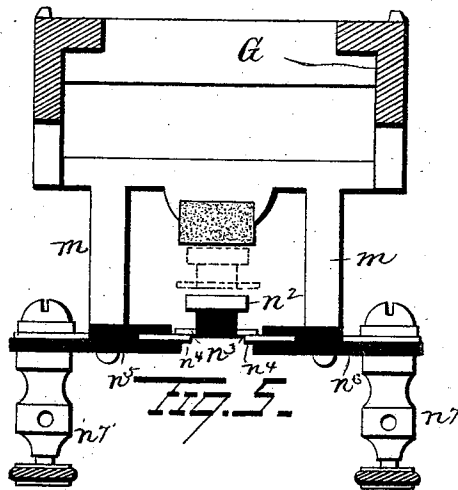
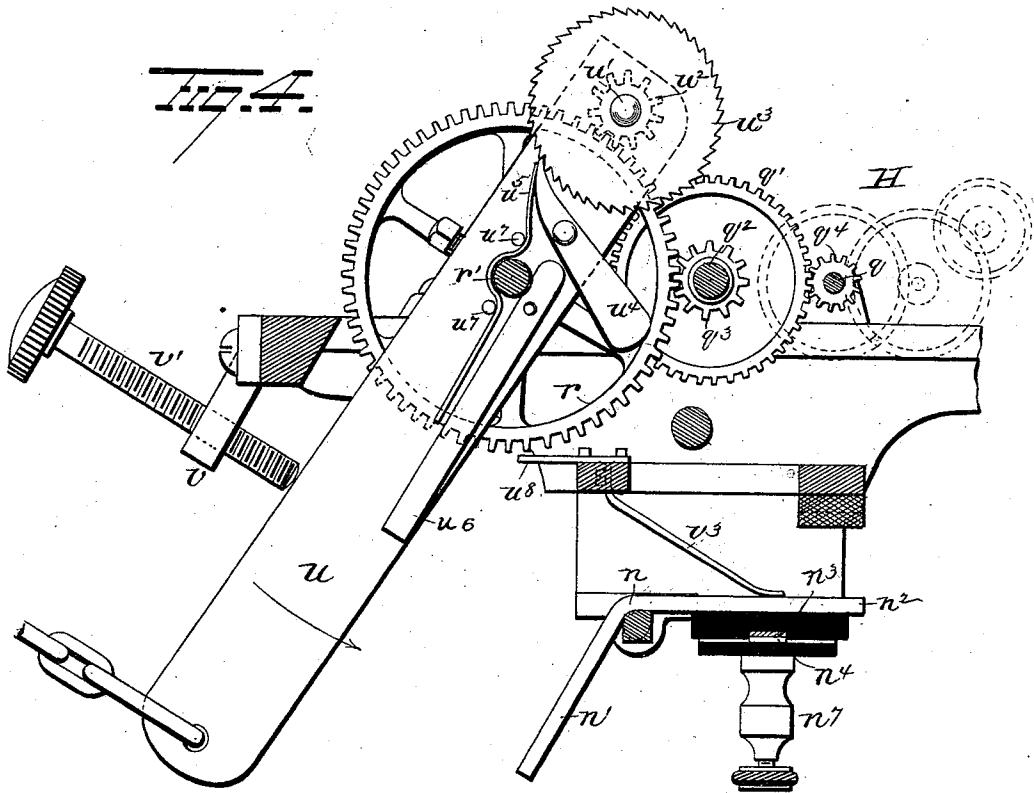

Witnesses
G. J. Downing

Inventor
R. D. Patterson
By *H. A. Seymour*
Attorney

UNITED STATES PATENT OFFICE.

ROBERT D. PATTERSON, OF LAWRENCE, MASSACHUSETTS.

ELECTRIC TIME-SIGNAL FOR RAILWAYS.

SPECIFICATION forming part of Letters Patent No. 525,277, dated August 28, 1894.

Application filed January 2, 1894. Serial No. 495,435. (No model.)

To all whom it may concern:

Be it known that I, ROBERT D. PATTERSON, a citizen of the United States, residing at Lawrence, in the county of Essex and State of Massachusetts, have invented certain new and useful Improvements in Electrical Signaling Apparatus; and I do hereby declare the following to be a full, clear, and exact description of the invention, such as will enable others skilled in the art to which it appertains to make and use the same.

My invention relates to an improvement in railroad signals,—the object of the invention being to so construct and arrange signaling apparatus that it will be effectually and automatically operated by a passing train to display a danger signal,—to maintain said signal displayed for a predetermined length of time and then to automatically return said signal to its normal or safety position.

A further object is to provide devices for the purpose stated which shall be simple in construction, not easy to get out of order and which shall be effectual in the performance of their functions.

With these objects in view the invention consists in certain novel features of construction and combinations and arrangements of parts as hereinafter set forth and pointed out in the claims.

In the accompanying drawings: Figure 1 is a view of the switch instrument for controlling the operations of the signal. Fig. 2 is a view of the signal apparatus. Fig. 3 is a view illustrating the track instrument. Figs. 4 and 5 are views illustrating details. Fig. 6 is a diagrammatical view.

The road on which my improved signals are located may be divided into sections of, say, five miles in length, and in each section the signals may be arranged one mile (more or less) apart, or a signal can be located at any dangerous point within the section and will be so operated as to display a danger signal for a length of time sufficient to permit a train, after passing it, to reach the end of the section. All the signals and the appliances for operating them being the same in construction, a description of one signal and the appliances or devices for operating it will suffice for all.

A represents a pole, which is to be located

at one side of the road, to the top of which pole a metallic post B is secured, and in the top of the post B, the pedestal *a* of a signal lantern C is pivotally supported. The signal lantern C is provided at diametrically opposite sides with red glass, and in the other two sides is provided with white glass. The signal lantern is also provided with wings *b*, one face of each wing being painted red and the other face of each wing being painted white. Thus when the signal is in one position, the red faces of all the wings will be displayed to indicate danger and when the signal is in the other position the white faces of all the wings will be displayed to denote safety.

Made integral with or secured to the pedestal *a* of the signal, is a grooved pulley *c*, over which a chain *d* passes and to which said chain is secured, as at *d*³. The chain *d* also passes over pulleys *d'*, *d'*, carried by a cross bar *d*². A weight *e* is secured to one end of the chain *d* and to the other end of said chain, the core *f* of a solenoid *f'* is attached, said solenoid being suitably supported by the post B. A guard or bracket *g* is secured to the post B and projects upwardly within the path of a pin *g'* projecting downwardly from the pulley *c*, thus limiting the oscillation of the signal lantern and preventing it from making more than one-fourth revolution at a time. Now it will be seen that the signal will be maintained in its normal position by the action of the weight *e*, but that when the solenoid *f'* is energized, the core *f* will be drawn into the same and the signal thus caused to make a quarter revolution and display the danger signal. As soon as the solenoid is de-energized by the breaking of the electric current, the signal will be returned to its normal position indicating safety, by the action of the weight *e*. A casing D is located below one of the rails *h* of the track, and is provided with a vertical post D' which terminates slightly above the surface of the road bed and is provided in proximity to its upper end with a recess *h'* for the reception of one of the flanges of the rail. The other flange of the rail enters a recess *h*² made at the upper end of a plate or bracket *h*³ secured to the post D'. The post D' and the top of the case D are made with a vertical opening for the passage of a movable rod D², the upper

end of which terminates in a button D^3 normally disposed slightly above the tread of the rail. Within the case D the rod D^2 is provided with a hub or enlargement h^4 , about
 5 which a spring i is coiled, one end of said spring bearing on a flange i' and the other end bearing on a block i^2 supported by brackets i^3 . The lower extremity of the rod D^2 enters a slot j made in the rear end of a lever
 10 E, and encircling said lower end of the rod and bearing on said lever is a spring E' . The lever E is pivoted at a point near its rear end, in brackets j' projecting upwardly from the bottom of the case D. The forward end
 15 of the lever E is provided with a metallic plate j^3 , which, when the lever is operated, engages two insulated plates k, k , and close an electric circuit, whereby to actuate devices presently to be described, whereby to actuate
 20 the signal. A post F is located at the side of the road in proximity to the track instrument, and supports a casing F' at its upper end.

Two posts or standards l , are located within
 25 the casing F' , and at their upper ends are made with perforated bosses for the reception of the trunnions of a rectangular, open frame G, said trunnions projecting laterally from said frame at points between the ends
 30 thereof. The frame G is made with two depending arms m , between which a lever n , having a downwardly and forwardly projecting arm n' , is pivotally supported. In proximity to the end of the arm n^2 of the lever n ,
 35 a plate n^3 is secured and suitably insulated therefrom, said plate n^3 being adapted to normally rest upon and electrically connect two plates n^4 , supported in a horizontal position at the ends of the arms m of frame G, by
 40 means of blocks n^5, n^6 of insulating material. Binding posts n^7 are secured to the insulating plates n^5, n^6 , and electrically connected to the horizontal contact plates n^4 . With one of the binding posts one pole of a battery is connected by means of a wire o , while the other binding post is connected with one end of the coil of the solenoid f' by a wire o' , the other end of said coil of the solenoid being connected, by a wire o^2 , with the other pole of the
 45 battery. Thus, when the plate n^3 is in contact with the contact plates n^4 , an electric circuit will be completed through the solenoid f' , and the signal C will be moved to danger by the action of the solenoid, in the manner
 50 above explained.

The frame G is maintained in a normally horizontal position by means of a spring p located under one end thereof. On the end of the frame G supported by the spring p , a
 60 clock-mechanism I is located, and the arbor q of said clock mechanism carries a pinion q^4 , which meshes with a spur wheel q' carried by a shaft or arbor q^2 . The shaft or arbor q^2 also carries a pinion q^3 adapted to mesh with
 65 a gear wheel r carried by the main driving shaft r' . A driving spring s is wound on the shaft r' , said spring being secured at one

end to said shaft and at the other end to the frame G. A hand or pointer s' is secured to the shaft r' and adapted to pass over a dial
 70 t , having degrees marked thereon indicating minutes, preferably ranging from 0 to 15, more or less.

Secured on the shaft r' is a lever u , in the upper end of which a short shaft u' is mounted.
 75 On one end of said shaft u' a pinion u^2 is secured and adapted to mesh with the gear wheel r , and on the other end of said shaft a ratchet wheel u^3 is fixed. A pawl u^4 is pivoted to the lever u and is adapted to be made
 80 to engage the teeth of the ratchet wheel u^3 by means of a spring u^5 . The other end of the spring u^5 bears against one end of a lever u^6 pivoted to the lever u , said spring being adapted between its ends to partially em-
 85 brace the shaft r' and is retained in proper position by means of pins u^7 projecting from the lever u . When the parts are in their normal, inactive positions, the lower end of the lever u^6 is in engagement with an arm u^8 pro-
 90 jecting from the frame G and the upper end of said lever is in engagement with the rear end of the pawl u^4 , and said pawl is thus normally retained out of engagement with the ratchet wheel u^3 . An arm v is secured to the
 95 end of the frame nearest the lever u and is provided with a screwthreaded perforation for the accommodation of a screw v' , whereby to limit the movement of the lever u . When the parts are in their normal positions, the
 100 lever u will assume a vertical position and in engagement with the arm n' of the lever n , thus normally maintaining the other arm of said lever carrying the contacting plate n^3 out of contact with the contact plates n^4 ,
 105 against the action of a spring v^3 . Thus it will be seen that when the parts are in their normal positions, the circuit through the solenoid of the signal will be open, but when the lower end of the lever u is moved upwardly, it
 110 will move out of engagement with the arm n' of the lever n , and said lever will be made to turn on its fulcrum by the action of the spring v^3 to cause the contact plate n^3 to make electrical contact with the contact plates n^4 , thus
 115 closing the circuit through the solenoid f' and operating the signal as above described. When the lever u is turned, the lever u^6 will move away from the arm u^8 , and the lower end of said lever u^6 being heavier than the
 120 upper end, the latter will move away from the pawl u^4 and thus permit said pawl to engage the ratchet wheel u^3 . When the lever u is moved from its normal position, the hand s' will be moved over the dial t , the spring s
 125 will be wound, and the shaft on which the pinion u^2 and ratchet wheel u^3 are secured, will be rotated by the meshing of said pinion with the gear wheel r . The movement of the lever u , will be limited, as above ex-
 130 plained, by the screw v' and said screw can be adjusted so that the mechanism will be caused to run fifteen minutes or any length of time less than fifteen minutes. If desired

the devices may be so constructed that they can be made to run more than fifteen minutes, but fifteen minutes is usually sufficient for the accomplishment of the purpose of my invention. Now when the mechanism has run the prescribed length of time (during which time the circuit which operates the signal is closed, retaining the signal at danger) the end of the lever u^6 will engage the arm u^8 , the upper end of said lever u^6 being thus made to move the pawl w^4 out of engagement with the ratchet wheel w^3 . The lever u being thus set free by the disengagement of the pawl w^4 from the ratchet wheel w^3 , said lever u will be forced quickly to its normal position by the action of the main driving spring s , on the shaft r' of which said lever is secured and caused to engage the arm n' of the lever n and raise the end of said lever which carries the contact plate n^3 , thus opening the circuit through the solenoid f' and de-energizing said solenoid, whereupon the signal will be returned to safety through the action of the weight e , as above explained. The frame G being pivotally supported between its ends, and one end being supported by the spring p , it will be seen that when the lower end of the lever u is raised and made to come into contact with the screw v' , said frame G will be given a sudden vibration, which will be sufficient to set the escapement of the clock work in motion.

In order to operate the lever u automatically, whereby to start the apparatus and thus operate the signal, the devices now to be described will be employed. The contact plates k, k , in the casing D of the track instrument, will be included in an electrical circuit with a suitable battery and a solenoid H located within the case F' . The solenoid H is provided with a guard w connected to the solenoid by trackways w' . The core H' of the solenoid H passes through the guard w and between the trackways w' , and is provided with pulleys or rollers w^2 adapted to run on said trackways. The end of the core H' is connected with the lower end of the lever u , by means of a chain x , or other suitable flexible connection. Now it will be seen that when the wheel y of a passing train runs over the track instrument, the circuit will be closed through the solenoid H , whereupon the core H' will be drawn within the solenoid and the lower end of the lever u will be raised, thus causing the circuit through the solenoid f' of the signal, to be closed, the signal set at danger and the mechanism connected with the lever u will be set in motion. The circuit through the solenoid H being closed by the passage of a train over the track instrument, it is evident that when the train shall have passed the track instrument, the solenoid H will be in an open circuit,—thus the solenoid will be de-energized very shortly after being energized to operate the lever u . The lever u will then move gradually toward its normal position, such gradual movement

being caused by the engagement of the pawl w^4 (carried by said lever) with the ratchet wheel w^3 , the latter being geared with the clock mechanism I . When the mechanism shall have run the predetermined length of time the lever u will assume its normal position, the circuit through the solenoid f' will be opened and the signal reset to safety, as above fully explained.

My invention is not only applicable for "block" signaling on steam rail roads, but may also be employed on electric roads. When the invention is thus employed, the track instrument will be so located that the button will be in the frog at the end of the turnout, so that when the car is leaving the turnout the flange of the wheel will operate the track instrument, thus starting the operating mechanism indicated in Fig. 1 of the drawings, and setting the signal, which is located near the next turnout, to danger.

At a junction or any part of the road where the "shifters" are moving to and fro all the time, the operating mechanism shown in Fig. 1 (with the exception of the solenoid H) can be located in the station, where one of the employés can start it to give the through trains the right of way.

The apparatus shown in Fig. 1, can, if desired, be located in a building where the opening of a door will start it and light a circuit of lights or ring a burglar alarm.

My improvements are simple in construction, not easy to get out of order and are effectual, in every respect, in the performance of their functions.

Various slight changes might be made in the details of construction of my invention without departing from the spirit thereof or limiting its scope and hence I do not wish to limit myself to the precise details of construction herein set forth, but,

Having fully described my invention, what I claim as new, and desire to secure by Letters Patent, is—

1. The combination with a signal, an electro-magnetic device adapted to cause said signal to be turned in one direction, and a track instrument or circuit closer, of devices adapted to be controlled by said track instrument or circuit closer, said devices being included in circuit with the electro-magnetic device and constructed and adapted to maintain said electro-magnetic device energized for a predetermined length of time, substantially as set forth.

2. The combination with a signal, an electro-magnetic device connected with said signal and adapted to turn the same, and a track instrument or circuit closer, of a solenoid included in an electric circuit with said track instrument, a current maker and breaker included in circuit with said electro-magnetic device and a lever adapted to maintain said last-mentioned circuit normally open, said lever being connected with the core of said solenoid, substantially as set forth.

3. The combination with a signal, an electro-magnetic device for turning said signal, and a track instrument, of a solenoid included in a normally open circuit with the track instrument, a lever connected with the core of said solenoid, a circuit maker and breaker in a normally open circuit with said electro-magnetic device, and means for regulating the return movement of said lever whereby to maintain the circuit through said electro-magnetic device closed for a predetermined length of time, substantially as set forth.

4. The combination with a signal and an electro-magnetic device adapted to turn said signal, of a circuit closer in circuit with said electro-magnetic device, a lever adapted to maintain said circuit closer normally open, means for operating said lever whereby to close the circuit closer, and means for controlling the return movement of said lever whereby to maintain the circuit closed for a predetermined length of time, substantially as set forth.

5. The combination with a signal and an electro-magnetic device adapted to turn the same, of a frame, a circuit closer carried by said frame and included in circuit with said electro-magnetic device, a lever mounted on said frame and adapted to maintain said circuit closer normally open, and clockwork connected with said lever whereby to regulate the return movement thereof and maintain the circuit closed for a predetermined length of time, substantially as set forth.

6. The combination with a signal and an electro-magnetic device adapted to turn the same, of a frame, a circuit closer carried by said frame and including said electro-magnetic device, means for maintaining said circuit closer normally open, means for closing said circuit closer, and means for maintaining said circuit closer closed for a predetermined length of time.

7. In signaling apparatus, the combination with a frame, a circuit closer carried by said frame, a lever adapted to maintain said circuit closer normally open, means for operating said lever whereby to close said circuit closer, clockwork for regulating the return movement of said lever, and means for releasing said lever when the predetermined length of time shall have expired, whereby to again open the circuit closer, substantially as set forth.

8. In signaling apparatus, the combination with a frame and clockwork located thereon, of a circuit closer carried by said frame, a shaft mounted on said frame and connected with said clockwork, a spring for rotating said shaft, a lever carried by said shaft and adapted to maintain the circuit closer normally open, means for operating said lever to close the circuit closer, and means for releasing said lever after a predetermined length of time whereby to automatically open said circuit closer, substantially as set forth.

9. In signaling apparatus, the combination with a frame and clockwork mounted on said frame, of a circuit closer carried by said frame, a shaft mounted on said frame a spring adapted to rotate said shaft, a gear wheel on said shaft adapted to transmit motion to said clockwork, a lever on said shaft adapted to maintain the circuit closer normally open, a short shaft carried by said lever, a pinion carried by said short shaft and adapted to mesh with said gear wheel, a ratchet wheel also carried by said short shaft, a pawl carried by the lever and adapted to engage the ratchet wheel, and means for automatically releasing said pawl from the ratchet wheel after a predetermined length of time, whereby to permit said lever to assume its normal position and open the circuit closer, substantially as set forth.

10. In signaling apparatus, the combination with a frame and clockwork mounted thereon, of a circuit closer carried by said frame, a shaft mounted on said frame, a spring for rotating said shaft, a lever and a gear wheel carried by said shaft, and adapted to maintain the circuit closer normally open, a short shaft carried by said lever, a pinion carried by said short shaft and meshing with the gear wheel, a ratchet wheel carried by said short shaft, a pawl carried by the lever and adapted to engage said ratchet wheel, a short lever pivoted to the first-mentioned lever and terminating in proximity to one end of said pawl, said short lever being adapted to engage the frame when the clockwork shall have run a prescribed length of time, and release the pawl from the ratchet wheel, whereby to permit the first-mentioned lever to promptly assume its normal position, stop the clockwork and open the circuit closer, substantially as set forth.

11. In signaling apparatus, the combination with a frame and a clockwork mounted thereon, of a circuit closer carried by said frame, a shaft mounted on the frame and carrying a hand at one end, a dial on the frame with which said hand registers, a spring for rotating said shaft, a lever carried by said shaft and adapted to maintain the circuit closer normally open, a gear wheel secured to said shaft and adapted to transmit motion to the clock work, a short shaft carried by said lever, a pinion carried by said short shaft and meshing with said gear wheel, a ratchet wheel also carried by said short shaft, a pawl carried by the lever and adapted to engage said ratchet wheel and means for automatically releasing said pawl from the ratchet wheel when the clockwork has run a prescribed length of time, whereby to cause said lever to open said circuit closer, substantially as set forth.

12. In a signaling apparatus, the combination with a pivotally supported frame, a clockwork on said frame, a circuit closer carried by said frame, and means for operating said circuit closer, of a spring located under one end of said pivotally supported frame, substantially as set forth.

13. In signaling apparatus, the combination with a frame, a clockwork mounted thereon and a circuit closer carried by said frame, of a shaft mounted on said frame, means for turning said shaft, means connecting said shaft with the clock work, a lever carried by said shaft and adapted to maintain the circuit closer normally open, and an adjustable screw for limiting the movement of said lever, substantially as set forth.

14. In a signaling apparatus, the combination with a frame, a clockwork mounted thereon, a shaft mounted on said frame, means for rotating said shaft, means for connecting said shaft with the clockwork, a circuit closer carried by said frame, and a lever secured to said shaft and adapted to maintain the circuit closer normally open, of a solenoid, having its core connected with said lever, and means for energizing and de-energizing said solenoid, substantially as set forth.

15. In a signaling apparatus, the combination with a frame, a clockwork mounted thereon, a shaft mounted on said frame, means for rotating said shaft, means for connecting said shaft with the clockwork, a circuit closer carried by said frame and a lever secured to said shaft and adapted to maintain the circuit closer normally open, of a solenoid having its core connected with said lever, trackways projecting from said solenoid, and rollers carried by the core of the solenoid and adapted to run on said trackways, substantially as set forth.

16. The combination with a circuit closer, of a pivoted lever adapted to maintain said circuit closer normally open, a solenoid having its core attached to said lever, trackways projecting from said solenoid, rollers carried by the core of the solenoid and adapted to run on said trackways, and a guard at the free ends of said trackways, substantially as set forth.

17. In a signaling apparatus, the combination with a post and a signal adapted to turn thereon, of a pulley carried by said signal, a chain passing about said pulley, a weight on one end of said chain, a solenoid and the core

of said solenoid attached to the other end of said chain, substantially as set forth. 50

18. In a signaling apparatus, the combination with a post, a cross bar on said post and pulleys carried by said cross bar, of a signal adapted to turn on said post, a pulley carried by said signal, a chain passing about said pulleys, a weight at one end of said chain, a solenoid and a core for said solenoid attached to the other end of said chain, substantially as set forth. 55

19. In a signaling apparatus, the combination with a post, and a signal adapted to turn thereon, of a pulley carried by said signal, a chain passing about said pulley and secured thereto, a bracket secured to said post, a pin projecting from said pulley and adapted to engage the bracket whereby to limit the movement of the signal, a weight at one end of said chain, a solenoid, and a core for said solenoid attached to the other end of said chain, substantially as set forth. 60 65 70

20. In a signaling apparatus, the combination with a signal, electro-magnetic devices for operating the same, and mechanism for controlling said electro-magnetic devices, of a casing adapted to be located under a railroad track, a rod projecting through said casing and terminating in proximity to the rail and above the tread thereof, a spring for maintaining said rod in such position, a pivoted lever in said casing and having a recess for the reception of said rod, a spring encircling said rod and bearing on said lever, a plate carried by the other end of said lever, insulated contact plates secured to the casing and adapted to be engaged by the plate carried by the lever whereby to close an electrical circuit whereby to actuate said controlling mechanism, substantially as set forth. 75 80 85

In testimony whereof I have signed this specification in the presence of two subscribing witnesses. 90

ROBERT D. PATTERSON.

Witnesses:

JOSEPH H. MCDADE,
WALTER COULSON.