



- (51) International Patent Classification: *B06B 3/00* (2006.01)
- (21) International Application Number: PCT/US2012/029051
- (22) International Filing Date: 14 March 2012 (14.03.2012)
- (25) Filing Language: English
- (26) Publication Language: English
- (30) Priority Data: 61/452,683 15 March 2011 (15.03.2011) US
- (71) Applicant (for all designated States except US): **E. I. DU PONT DE NEMOURS AND COMPANY** [US/US]; 1007 Market Street, Wilmington, Delaware 19898 (US).
- (72) Inventor; and
- (75) Inventor/Applicant (for US only): **HARDING, Thomas** [US/US]; 1312 Quincy Drive, Wilmington, DE 19803 (US).
- (74) Agents: **SAFRAN, Jeffrey, B.** et al.; Potter Anderson & Corroon LLP, P.O. Box 951, 1313 N. Market Street, Wilmington, Delaware 19899-0951 (US).
- (81) Designated States (unless otherwise indicated, for every kind of national protection available): AE, AG, AL, AM, AO, AT, AU, AZ, BA, BB, BG, BH, BR, BW, BY, BZ, CA, CH, CL, CN, CO, CR, CU, CZ, DE, DK, DM, DO, DZ, EC, EE, EG, ES, FI, GB, GD, GE, GH, GM, GT, HN, HR, HU, ID, IL, IN, IS, JP, KE, KG, KM, KN, KP, KR, KZ, LA, LC, LK, LR, LS, LT, LU, LY, MA, MD, ME, MG, MK, MN, MW, MX, MY, MZ, NA, NG, NI, NO, NZ, OM, PE, PG, PH, PL, PT, QA, RO, RS, RU, RW, SC, SD, SE, SG, SK, SL, SM, ST, SV, SY, TH, TJ, TM, TN, TR, TT, TZ, UA, UG, US, UZ, VC, VN, ZA, ZM, ZW.
- (84) Designated States (unless otherwise indicated, for every kind of regional protection available): ARIPO (BW, GH, GM, KE, LR, LS, MW, MZ, NA, RW, SD, SL, SZ, TZ, UG, ZM, ZW), Eurasian (AM, AZ, BY, KG, KZ, MD, RU, TJ, TM), European (AL, AT, BE, BG, CH, CY, CZ, DE, DK, EE, ES, FI, FR, GB, GR, HR, HU, IE, IS, IT, LT, LU, LV, MC, MK, MT, NL, NO, PL, PT, RO, RS, SE, SI, SK,

[Continued on next page]

(54) Title: DEVICE FOR SHEARING NUCLEIC ACIDS AND PARTICULATES

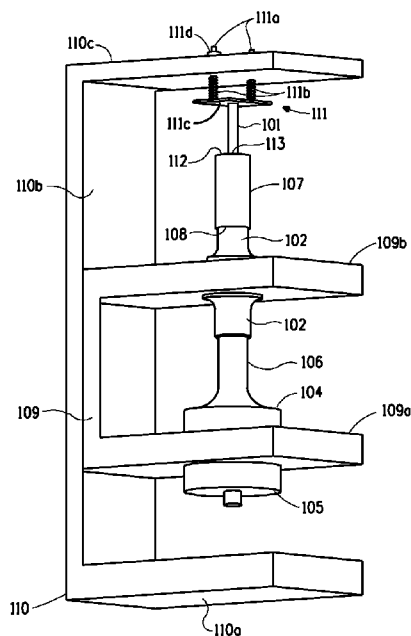

FIG. 1

(57) Abstract: Disclosed herein are processes for collecting nucleic acids from particulate samples. One embodiment disclosed herein relates to the use of ultrasonic energy to simultaneously shear large nucleic acid molecules and large particulates to very small sizes prior to or during a chemical binding step to a nucleic acid binding surface. Another embodiment involves crushing the nucleic acid binding surface prior to eluting the bound nucleic acid molecules to enable better wetting of the nucleic acid binding surface and easier diffusion of bound nucleic acid molecules out of the nucleic acid binding surface.



SM, TR), OAPI (BF, BJ, CF, CG, CI, CM, GA, GN, GQ, GW, ML, MR, NE, SN, TD, TG). **Published:**

— *without international search report and to be republished upon receipt of that report (Rule 48.2(g))*

TITLE

DEVICE FOR SHEARING NUCLEIC ACIDS AND PARTICULATES

CROSS-REFERENCE TO RELATED APPLICATION

5 This application claims benefit of U.S. Provisional Patent Application No. 61/452,683, filed March 15, 2011, which is incorporated by reference herein in its entirety.

FIELD OF INVENTION

10 The field relates to devices for shearing nucleic acids and particulates in syringe or vial.

BACKGROUND OF INVENTION

15 The analysis of samples for microorganisms, such as bacteria, is important for public health. Foods grown, purchased, and consumed by the general population may contain or acquire microorganisms, which flourish or grow as a function of the environment in which they are located. This growth may lead to accelerated spoilage of the food product or the proliferation of pathogenic organisms, which may produce toxins or allergens.

20 In the course of analyzing samples from microorganisms in foods, one must contend with large nucleic acid molecules and large particulates that can hinder later detection steps. As such, there is a need for a device that can reduce the size of these large nucleic acid molecules and particulates while retaining the detectability of the nucleic acids.

25

SUMMARY OF INVENTION

One aspect is for a device for shearing nucleic acids and particulates in a syringe or vial comprising an ultrasonic transducer attached to a solid cylindrical horn, said horn comprising a tip shaped to engage the profile of the tip of a syringe
30 or vial and said horn tuned for maximum amplitude vibration at the tip of the horn.

Another aspect is for a device for shearing nucleic acids and particulates in a syringe or vial comprising an ultrasonic transducer; a solid cylindrical horn, said horn comprising a tip shaped to engage the side profile of a syringe or vial and said horn tuned for maximum amplitude vibration at the tip of the horn; a tuned booster
5 detachably engaged to the ultrasonic transducer and the solid cylindrical horn; and an anvil mated to the horn, said anvil being capable of clamping the horn to the syringe or vial.

Other objects and advantages will become apparent to those skilled in the art upon reference to the detailed description that hereinafter follows.

10

BRIEF DESCRIPTION OF THE FIGURES

Figure 1 shows a first embodiment of a device for shearing nucleic acids and particulates.

15 **Figure 2** shows a second embodiment of a device for shearing nucleic acids and particulates.

DETAILED DESCRIPTION OF PREFERRED EMBODIMENTS

Applicant specifically incorporates the entire contents of all cited references in
20 this disclosure. Further, when an amount, concentration, or other value or parameter is given as either a range, preferred range, or a list of upper preferable values and lower preferable values, this is to be understood as specifically disclosing all ranges formed from any pair of any upper range limit or preferred value and any
25 lower range limit or preferred value, regardless of whether ranges are separately disclosed. Where a range of numerical values is recited herein, unless otherwise stated, the range is intended to include the endpoints thereof, and all integers and fractions within the range. It is not intended that the scope of the invention be limited to the specific values recited when defining a range.

Figure 1 shows a first embodiment of the device for shearing nucleic acids
30 and particulates. Referring to **Figure 1**, the ultrasonic transducer **104**, **105**, **106** comprises a Piezoelectric crystal stack (not shown) inside a housing **104** capable of

oscillating in response to energy input from a power supply, not shown. The vibratory energy from the piezoelectric crystal stack is transmitted to the element **106** and is substantially distributed in a direction towards the syringe or vial **101**. The ultrasonic transducer **104, 105, 106** can be piezoelectric transducer or a
5 magnetostrictive transducer. A piezoelectric transducer can be manufactured from any common piezoelectric material, such as lead zirconate titanate which expands and contracts when provided with the appropriate AC electrical voltage at the correct frequency. A magnetostrictive transducer is essentially an electromagnet made of a heavy nickel or alloy core which is wound with wire. As electrical current is pulsed
10 through the wires, the core vibrates at a frequency which matches the output frequency of the ultrasonic generator. Preferably, the ultrasonic transducer **104, 105, 106** is a piezoelectric transducer. More preferably, the ultrasonic transducer is a Dukane Corp. (St. Charles, IL) piezoelectric device, model 41C28, that is fed an AC voltage of a particular frequency (for example, 40 kHz) by a power supply
15 (Dukane Corp. Model 40A351). The electrical energy is converted into mechanical vibration that travels from the transducer to the horn and sets up a standing wave in the stack of transducer, booster (when present), and horn with the stack vibrating in the axial direction.

The optional tuned booster **102** amplifies or modifies the vibrations generated
20 by the ultrasonic transducer **104** to the solid cylindrical horn **107**. When present, the tuned booster **102** is detachably mounted to the front end **106** of the ultrasonic transducer **104**, and detachably mounted to the back end portion **108** of the solid cylindrical horn **107**. The ultrasonic energy transmitted through the tuned booster **102** to the solid cylindrical horn **107** propagates in the particulate sample containing
25 nucleic acids in the syringe or vial. As a result, large nucleic acids and/or particulates in the particulate sample are sheared by the ultrasonic energy. The tuned booster section is typically made of titanium or aluminum.

The end of the solid cylindrical horn **107** is an antinode in the vibration and vibrates with maximum amplitude at the tip **112**. In a preferred embodiment, the tip
30 **112** contains a concave syringe or vial receiving section **113** designed to hold the syringe or vial **101** in a vertical orientation. In a preferred embodiment, the syringe

or vial receiving section **113** can be machined to match the shape of the tip of the syringe or vial **101** to ensure proper seating of the syringe or vial **101** in the syringe or vial receiving section **123** and to ensure good energy transfer from the horn tip **112** to the vial or syringe **101**.

5 The solid cylindrical horn **107** comprises a stiff or rigid material and may be formed of a variety of materials including, without limitation, aluminum, titanium, and MONEL® (nickel/copper alloy). Preferably, the solid cylindrical horn **107** is aluminum.

10 The device is supported by a base plate **110**. Preferably, the base plate **110** comprises a base **110a** in an orthogonal relationship to a side **110b** which in turn is in an orthogonal relationship to a top **110c** resulting in the base **110a** and the top **110c** being essentially parallel to each other. When using the device, the base **110a** acts as the bottom of the device and can be attached to a further support mechanism (for example, a table) to ensure stability of the device when in operation.

15 The base material can be aluminum or any other material that provides structural rigidity.

 Attached to the side **110b** of the base **110**, preferably removably attached, is a transducer mounting yoke **109**. As shown in **Figure 1**, the ultrasonic transducer **104** can be mounted in the transducer mounting yoke **109**. Regardless of

20 arrangement, the ultrasonic transducer **104** can be either removably or fixedly attached to the transducer mounting yoke **109**. In embodiments lacking a tuned booster **102**, the active element **106** of the ultrasonic transducer **104** passes through an opening constructed in the top **109b** of the transducer mounting yoke **109** to the active element's **106** attachment to the solid cylindrical horn **107**. In embodiments

25 utilizing a tuned booster **102**, for example as shown in **Figure 1**, it is the tuned booster **102** that passes through an opening constructed in the top **109b** of the transducer mounting yoke **109** to the tuned booster's **102** attachment to the solid cylindrical horn **107**. The transducer mounting yoke components are typically made of aluminum or steel but any sufficiently rigid material can be used.

30 If a vial is used, the horn tip **112** can be machined to match the profile of the end of the vial. For instance, if a round bottom vial is used, then a hemispherical

depression can be machined in the horn to match the vial profile to ensure maximum contact and hence maximal energy transfer to the vial contents. To improve energy transfer, fluids such as oils can be used to improve sound coupling. The tip **112** could also be coated with a thin layer of rubber or other conformable material to
5 improve the coupling of sound energy into the syringe or vial **101**.

In a preferred embodiment of the first device, a one inch diameter cylindrical horn was used with a tip that was machined to match the profile of the end of a plastic syringe or plastic vial. This is done to ensure maximum contact between the horn and the syringe to maximize the transfer of sound energy into the fluid. For
10 instance, the plastic 5 cc syringe that was used had a shallow conical end and a standard tapered Luer tip. A shallow conical depression was machined into the horn end to match the syringe and a 3/16 inch diameter hole was drilled axially to accommodate the Luer tip and a metal plug. In some embodiments, hand pressure was used to push the liquid filled syringe onto the horn end. Preferably though, and
15 as shown in **Figure 1**, a spring loaded device **111** was used to push the syringe or vial **101** onto the horn tip **112**. The spring loaded device **111** is employed to ensure repeatable pressure and orientation of the syringe or vial **101**.

The spring loaded device **111** is removably attached to the top **110c** of the base plate **110**, preferably through a bolting mechanism **111a**. In **Figure 1**, the
20 spring loaded device **111** is shown as having two springs **111b**, though one spring or three springs or more are acceptable. The bolting mechanism **111a** passes through the top **110c** of the base plate **110** and is attached, preferably removably attached, to a pressure plate **111c**. The pressure plate **111c** engages the syringe or vial **101** to push the syringe or vial **101** onto the horn tip **112**. The spring **111b** is fitted on the
25 bolting mechanism **111a** prior to the bolting mechanism's **111a** insertion through the underside of the top **110c** of the base plate **110**. A bolt **111d** or similar locking device is used to secure the bolting mechanism **111a** to the top **110c** of the base plate **110** and to ensure proper distance between the pressure plate **111c** and the tip **112** of the solid cylindrical horn **107**.

Figure 2 shows a second embodiment of the device for shearing nucleic acids and particulates. The ultrasonic transducer **104, 105, 106** of the second embodiment is as described above for the first embodiment.

The solid cylindrical horn **123** of the second embodiment is shaped such that its end opposite that in contact with the ultrasonic booster **102** is capable of engaging the profile of the syringe or vial **101**. This tip **115** of the solid cylindrical horn **123** is also shaped so that it does not contact the front end portion **117** of the anvil **116**. As with the first embodiment, the solid cylindrical horn **123** of the second embodiment comprises a stiff or rigid material with low acoustic loss and may be formed of a variety of materials including, without limitation, aluminum, titanium, or MONEL® (nickel/copper alloy). Preferably, the solid cylindrical horn **123** is aluminum.

The tuned booster **102** is detachably mounted to the transducer front end **106** of the ultrasonic transducer **104, 105, 106**, and detachably engages the back end portion **120** of the solid cylindrical horn **123**. The ultrasonic energy transmitted through the tuned booster **102** to the solid cylindrical horn **123** propagates in the particulate sample containing nucleic acids in the syringe or vial. As a result, large nucleic acids and/or particulates in the particulate sample are sheared by the ultrasonic energy.

The second embodiment device is supported by a base plate **124**. Preferably, the base plate **124** comprises a base **124a** in an orthogonal relationship to a side **124b**. When using the device, the base **124a** acts as the bottom of the device and can be attached to a further support mechanism (for example, a table) to ensure stability of the device when in operation. The anvil **116** is attached, preferably removably attached, to side **124b** of the base plate **124** at the opposite end of the anvil **116** to the front end portion **117**. The anvil can be made of, e.g., aluminum or titanium.

As shown in **Figure 2**, the ultrasonic transducer **104** can be mounted in the transducer mounting yoke **109**. The ultrasonic transducer **104** can be either removably or fixedly attached to the transducer mounting yoke **109**. The tuned booster **102** passes through an opening constructed in the horn side **109d** of the

transducer mounting yoke **109** to the tuned booster's **102** attachment to the solid cylindrical horn **123**.

In some embodiments (not shown in **Figure 2**), the transducer mounting yoke **109** has its transducer side **109c** and its horn side **109d** split transverse to the transducer **104**, and booster axis and clamp bolts are used to hold the transducer **104** between the transducer side **109c** and its horn side **109d** of the transducer mounting yoke **109**.

A support post **121** is attached to base **124a** of the base plate **124**. The support post **121** contains at the end opposite of the support post's **121** attachment to the base plate **124** a concave syringe or vial receiving section **122** designed to hold the syringe or vial **101** in a vertical orientation. In a preferred embodiment, the syringe or vial receiving section **122** can be machined to match the shape of the tip of the syringe or vial **101** to ensure proper seating of the syringe or vial **101** in the syringe or vial receiving section **122**.

In the second embodiment, the transducer mounting yoke **109** is not attached to the base **124**. Instead, the transducer mounting yoke **109** is movable along the axis defined by the solid cylindrical horn **123** and the anvil **116**. Preferably, such motion is accomplished by having the transducer mounting yoke **109** mounted on a ball slide **118** that is movably engaged with a pneumatic or hydraulic cylinder or a spring capable of supplying a clamping force between the horn and the anvil. As shown in **Figure 2**, a pneumatic cylinder **119** is attached to the base **124a** of the base plate **124** by a pneumatic cylinder support **119b**. A cylinder body **119a** extends in the direction of the ball slide **118** and is connected thereto by a plunger **119c**. The ball slide **118** operates by applying air pressure to the pneumatic cylinder **119** thereby extending the plunger **119c** which pushes on the ball slide and transducer mounting yoke **109**.

The syringe or vial **101** containing a particulate sample containing nucleic acids is inserted into the syringe or vial receiving section **122** when the pneumatic cylinder **119** and plunger **119c** are retracted. Air pressure is applied to the pneumatic cylinder **119** and the ball slide **118**, transducer yoke **109** and transducer **104** are pushed forward so that the tip **115** of the solid cylindrical horn **123** engages

the syringe or vial **101**. Preferably, the front end portion **117** of the anvil **116** also engages the syringe or vial **101** to increase the effectiveness of ultrasonic energy transmission into the syringe or vial **101** and/or to aid in supporting the syringe or vial **101** in a vertical orientation.

5 In a preferred embodiment, the second device uses an ultrasonic transducer, booster and horn, and an anvil to clamp a liquid filled syringe or vial in a way that transmits sound energy into the side of the syringe or vial. The horn tip and mating anvil have a semi-cylindrical cut in their ends that is transverse to the horn and transducer axis and whose radius is matched to the syringe or vial cylindrical radius.

10 If the syringe or vial is tapered slightly, then the cut can be tapered to match. This ensures maximum contact area with the syringe or vial and ensures maximum transfer of sound energy to the contents of the vial. The diameter of the horn is chosen to match the height of the liquid in the syringe or vial. The transducer and horn assembly is mounted to a ball slide that allows one dimensional motion. The

15 components are further mounted on a base. A pneumatic cylinder is used to apply pressure to the transducer and horn that squeezes the syringe or vial into the fixed anvil. The horn and anvil are machined in such a way that when the vial is clamped between the horn and anvil, there is no contact between the horn and anvil. This arrangement has an advantage in that the area of contact with the syringe or vial is

20 larger and allows for more efficient transfer of sound energy into the liquid contents compared to the first embodiment. However, if the quantity of fluid in the syringe or vial is small, less than 0.5 cc, for instance, then the first device is the better arrangement to use for sonication.

 In a preferred embodiment, the transducer (e.g., Dukane Corp. model 41C28)

25 is powered by a power supply (e.g., Dukane Model 40A351) that supplies electrical power at high voltage and at, e.g., 40 kHz frequency to the transducer via a coaxial cable. The high frequency, high voltage signal is applied to the faces of the piezoelectric crystals inside the transducer and the electrical energy is converted to mechanical vibration by the crystal stack. This vibrational energy is transferred to

30 the end of the transducer and into the booster and horn.

The intensity of the sonic energy may vary widely. Best results will generally be achieved with an intensity ranging from about 1 W/cm² to about 30 W/cm².

The residence time of exposure of the nucleic acids and/or particulates in the syringe or vial to ultrasound is not critical, and the optimal residence time will vary
5 according to the sample being treated. Best results, however, will generally be obtained with residence times ranging from about 1 second to about 2 minutes, preferably about 1 second to about 30 seconds.

CLAIMS

What is claimed is:

1. A device for shearing nucleic acids and particulates in a syringe or vial comprising an ultrasonic transducer attached to a solid cylindrical horn, said horn comprising a tip shaped to engage the profile of the tip of a syringe or vial and said horn tuned for maximum amplitude vibration at the tip of the horn.
2. The device of claim 1, wherein the horn comprises a material selected from the group consisting of aluminum, titanium, and MONEL (nickel/copper alloy).
3. The device of claim 1, further comprising a tuned booster detachably engaged to the ultrasonic transducer and the solid cylindrical horn.
4. The device of claim 1, wherein the horn comprises on its surface a conformable material capable of improving coupling of sound energy into the syringe or vial.
5. The device of claim 4, wherein the conformable material is a thin layer of rubber.
6. The device of claim 1, wherein the ultrasonic transducer is piezoelectric.
7. The device of claim 1, wherein the ultrasonic transducer is magnetostrictive.
8. A device for shearing nucleic acids and particulates in a syringe or vial comprising
 - an ultrasonic transducer;
 - a solid cylindrical horn, said horn comprising a tip shaped to engage the side profile of a syringe or vial and said horn tuned for maximum amplitude vibration at the tip of the horn;

a tuned booster detachably engaged to the ultrasonic transducer and the solid cylindrical horn; and

an anvil mated to the horn, said anvil being capable of clamping the horn to the syringe or vial.

9. The device of claim 8, wherein said tip and anvil each have a semi-cylindrical cut in their respective ends that is transverse to the horn and transducer axis.

10. The device of claim 9, wherein said ultrasonic transducer is mounted on a ball slide.

11. The device of claim 10, wherein the ball slide is connected to a pneumatic or hydraulic cylinder or spring capable of supplying a clamping force between the horn and the anvil.

12. A method of sonicating the contents of a syringe or vial comprising exposing the syringe or vial to ultrasonic energy generated by the device of claim 1 or 8.

1/2

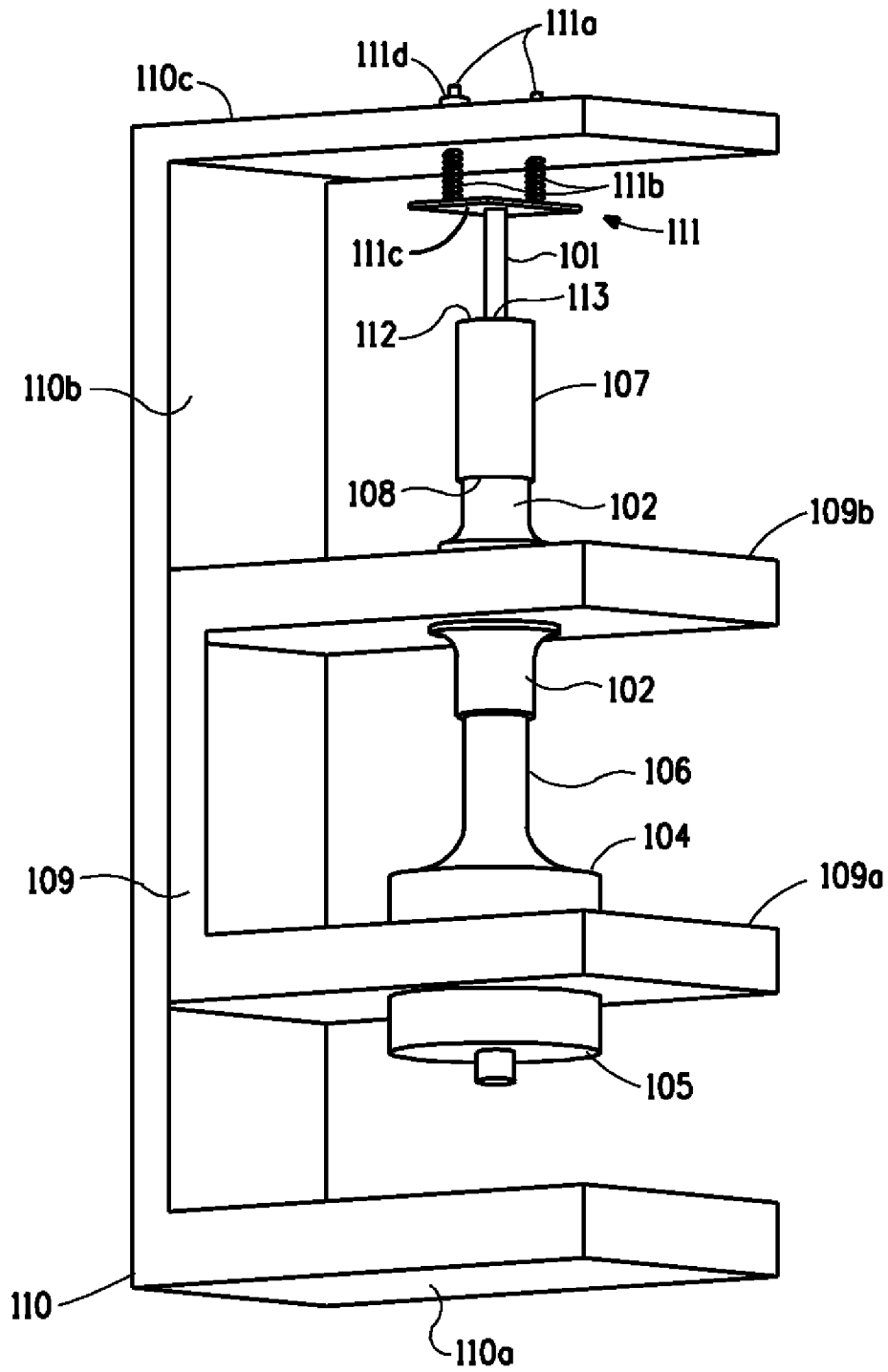

FIG. 1

