

(19) **DANMARK**

(10) **DK/EP 3856984 T3**



(12) **Oversættelse af
europæisk patentskrift**

Patent- og
Varemærkestyrelsen

-
- (51) Int.Cl.: **E 04 B 1/14 (2006.01)** **E 04 B 1/38 (2006.01)** **E 04 B 1/61 (2006.01)**
E 04 C 2/38 (2006.01) **E 04 D 3/366 (2006.01)**
- (45) Oversættelsen bekendtgjort den: **2022-12-12**
- (80) Dato for Den Europæiske Patentmyndigheds bekendtgørelse om meddelelse af patentet: **2022-09-14**
- (86) Europæisk ansøgning nr.: **18785690.1**
- (86) Europæisk indleveringsdag: **2018-09-28**
- (87) Den europæiske ansøgnings publiceringsdag: **2021-08-04**
- (86) International ansøgning nr.: **FI2018050702**
- (87) Internationalt publikationsnr.: **WO2020065123**
- (84) Designerede stater: **AL AT BE BG CH CY CZ DE DK EE ES FI FR GB GR HR HU IE IS IT LI LT LU LV MC MK MT NL NO PL PT RO RS SE SI SK SM TR**
- (73) Patenthaver: **CC Wizard OY, Maamiehentie 5, 13430 Hämeenlinna, Finland**
- (72) Opfinder: **Kinnunen, Jorma, Maamiehentie 5, 13430 Hämeenlinna, Finland**
- (74) Fuldmægtig i Danmark: **AWA Denmark A/S, Strandgade 56, 1401 København K, Danmark**
- (54) Benævnelse: **BYGGESYSTEM OG FREMGANGSMÅDE**
- (56) Fremdragne publikationer:
EP-A2- 0 624 695
US-A- 3 282 613
US-A- 4 633 634
US-B1- 6 363 674

DESCRIPTION

BACKGROUND

[0001] The invention relates to a building system for constructing a building.

[0002] The invention further relates to a method for constructing a building.

[0003] It is known to build buildings based on a metal frame construction. The metal frame may give advantages in greater strength, fire resistance and architectural design flexibility, for instance. A thermal insulation layer is attached to the metal frame either outside of the metal frame or between metal profiles that form the metal frame.

[0004] A problem with the metal frame constructions is that they usually are based on the idea just to replace a wooden frame construction by metal components. The building cost is relatively high because of the costly materials and the skilled crew and special equipment are needed to assemble the building. Therefore, the construction technique is generally considered unsuitable for single family residence building.

[0005] US 3 282 613 A relates to a panel assembly, and more particularly to an interlocked insulated panel assembly joined without bolts or like connectors to form a completed structural building paneling having uniquely scaled, flush, connection joints.

BRIEF DESCRIPTION

[0006] Viewed from a first aspect, there can be provided a building system for constructing a building, the system comprising: plurality of prefabricated elements, the element comprising: a self-supporting insulation panel comprising a rigid insulation material and having two straight and parallel edge surfaces, and an outer and inner surfaces, a metal frame, comprising a pair of sub-frames, a first sub-frame attached to a first edge surface and a second sub-frame attached to a second edge surface of the insulation panel, the sub-frame extending along the length of the insulation panel, the length of the sub-frame having a cross-section comprising an attaching arm extending along the corresponding edge surface, and an intruding section arranged in the attaching arm and in an angle respect to that, the intruding section intruding into the insulation element, and a box-type structure arranged distally from the intruding section and comprising walls and corners constituting a closed or partly open construction, the box-like structure extending from the attaching arm and being arranged on the outer surface or on the inner surface of the insulation panel, the building system further comprising a connecting element, being at least essentially as long as the sub-frame and having a cross-section comprising two arms and a connecting section connecting said two arms, the cross-section having basically a shape of an U-profile, the connecting element, in use, being

arranged on sub-frames of two adjacent elements, said arms being situated on opposite side of the two sub-frames and keeping together said sub-frames of adjacent elements. Thereby a building system easy to assemble may be achieved.

[0007] Viewed from a further aspect, there can be provided a method for constructing a building, the method comprising: connecting two of prefabricated elements described above by contacting their opposite edge surfaces to each other, attaching the sub-frames of said prefabricated elements to each other, arranging the connecting element according to any of the preceding claims on said sub-frames, and attaching said connecting element to said sub-frames. Thereby a method that produces a supporting structure and insulated structure quickly and easily may be achieved. The arrangement and the method are characterised by what is stated in the independent claims. Some other embodiments are characterised by what is stated in the other claims. Inventive embodiments are also disclosed in the specification and drawings

BRIEF DESCRIPTION OF FIGURES

[0008] Some embodiments illustrating the present disclosure are described in more detail in the attached drawings, in which

Figure 1 is a schematic view of detail of a building system for constructing a building,

Figures 2a - 2h are schematic top views of embodiments of sub-frames of the arrangement,

Figures 3a - 3g are schematic top views of embodiments of connecting elements of the arrangement, and

Figure 4 is a schematic top view of an assembly method step of the arrangement.

[0009] In the figures, some embodiments are shown simplified for the sake of clarity. Similar parts are marked with the same reference numbers in the figures.

DETAILED DESCRIPTION

[0010] Figure 1 is a schematic view of detail of a building system for constructing a building. The system 100 comprises plurality of prefabricated elements 1 that are connected together for creating a wall, a floor, a roof or a ceiling of a building. Thus, in an embodiment, the prefabricated element 1 is a wall element. In another embodiment, the prefabricated element 1 is a floor element. In a third embodiment, the prefabricated element 1 is a ceiling element.

[0011] The element 1 comprises a self-supporting insulation panel 2 comprising a rigid thermal

insulation material and having two straight and parallel edge surfaces 6a, 6b, and an outer and inner surfaces 8, 9.

[0012] According to an aspect, the material of the insulation panel 2 comprises at least one of the following materials: polyisocyanurate (PIR), polyurethane (PUR) and extruded polystyrene(XPS), or another rigid insulation material. In an embodiment, the insulation panel 2 has a homogenous structure and material, e.g. rigid foam insulation material, from its outer surface to its inner surface.

[0013] In an embodiment, the insulation panel 2 has a shape of rectangle. The dimensions of the element 1 may be e.g. 1200 mm (width) × 3000 mm (height). According to an idea, the width of the element is selected in range of 300 mm to 2400 mm, and the height 600 mm to 15000 mm. In an embodiment, the thickness of the insulation panel is selected in range of 100 mm to 300 mm, and the thickness of the insulation panel is uniform from its first edge surface to another edge surface.

[0014] The element 1 further comprises a metal frame 3 that includes a pair of sub-frames: a first sub-frame 7a attached to a first edge surface 6a and a second sub-frame 7b attached to a second edge surface 6b of the insulation panel 2. In an embodiment, the sub-frame 7a, 7b extends along the entire length of the insulation panel 2, i.e. the length of the sub-frame is 100 % of length of the insulation panel. However, said length may be essentially more; in an embodiment the length of the insulation panel 2 is 80 - 99 % of the length of the sub-frame 7a, 7b.

[0015] In still another embodiment, the sub-frame 7a, 7b is essentially longer than the insulation panel 2, such that the metal frame 3 makes it possible to attach two or more insulation panels 2 one on the other.

[0016] In an embodiment, the insulation panel 2 is essentially longer than the sub-frame 7a, 7b, so that an upper edge of the panel extends above upper ends of the sub-frames. The extension may be e.g. 100 mm - 500 mm, or 20 % of the length of the insulation panel. In an embodiment, the extension has same thickness as the rest of the insulation panel. In another embodiment, the extension is thinner, e.g. 50 mm - 100 mm. An advantage of the extension is that it insulates a roof space above the room, and may also be useful to limit the roof space when applying loose wool, such as loose mineral wool, therein.

[0017] In an embodiment, the sub-frame 7a, 7b is of bended sheet metal, thickness of which is in range of 0.5 - 3 mm. Also the auxiliary profile 25 may be of similar material. The material may comprise e.g. steel. In an embodiment, the steel is a strain hardening steel, such as DP780/980. An advantage is that the element stands well against high loads, and loads exceeding yield strength of the material are adsorbed in deformations of the structure. However, the steel may also be selected from group of conventional structural steels.

[0018] In an embodiment, the sub-frame 7a, 7b is attached to the insulation panel 2 by a glue

layer 22. The glue layer may be arranged between an attaching arm 10 of the sub-frame and the corresponding edge surface 6a, 6b, and/or between a box-type structure 12 of the sub-frame and the corresponding surface of the insulation panel. Also the intruding section 11 may be glued to the insulation panel 2.

[0019] In an embodiment, the metal frame 3 or, at least the surfaces thereof to be glued, have a special surface that enhances adhesion of the glue. Preferably, the strength of the glued joint is defined by cohesion strength of the glue, not adhesion of the glue to the surface. The special surface may be produced by a passivating zinc plating, a ground coating, an anti-fingerprint treatment, or an activation process such as a corona or a flame treatment.

[0020] The sub-frames 7a, 7b are attached to the insulation panel 2 in the manufacturing phase of the element 1. The glue may be e.g. polyurethane (PUR) or silyl modified polymer (SMP). An advantage of the SMP is that in the gluing process there is not released any potentially harmful emissions.

[0021] According to an aspect, there is layer of at least 20 mm, preferably at least 70 mm, of insulation panel between the outer surface 8 and the attaching arm 10. An advantage is that the good insulation properties of the wall/ceiling/floor may be ensured.

[0022] The building system 100 shown in Figure 1 further comprises a connecting element 4 that is at least essentially as long as the sub-frame 7a, 7b. In another embodiment, the connecting element 4 is essentially shorter than the sub-frame 7a, 7b, e.g. 80 % of the length of the sub-frame. When connecting two elements 1, the connecting element 4 is arranged on sub-frames 7a, 7b of two adjacent elements 1. The connecting element 4 keeps together said sub-frames 7a, 7b of adjacent elements 1.

[0023] In an embodiment, the metal frame 3 comprises at least one auxiliary profile 25 is attached to the prefabricated element 1 between two sub-frames 7a, 7b. The auxiliary profile 25 may bear load and give support for cladding or facing panels attached to the building system 100. The auxiliary profile may be attached to the element 1 in manufacturing of the element 1, or in a construction site of the building.

[0024] **Figures 2a - 2h** are schematic top views of embodiments of sub-frames of the arrangement.

[0025] The cross-section (transverse to the length of thereof) of the sub-frame 7a, 7b comprises an attaching arm 10 extending along the corresponding edge surface 6a, 6b, and an intruding section 11 that is arranged in the attaching arm 10 in an angle, preferably in right angle, respect to the attaching arm 10. The intruding section 11 intrudes into the insulation element 2, thus attaching the sub-frame to the insulation element.

[0026] The cross-section of the sub-frame 7a, 7b further comprises a box-type structure 12 arranged distally from the intruding section 11. In an embodiment, the length of the box-type

structure 12 is somewhat shorter than the length of the sub-frame 7a, 7b. This is especially the case in those embodiments where the box-type structures 12 are arranged to carry a transversal upper frame member 28, shown in Figure 1, the upper surface of which is to be adapted to the same level with the upper end of the sub-frames. The box-type structures 12 carry largely vertical loads exerting to the building system 100.

[0027] In an embodiment, the essentially whole of the length of the sub frame 7a, 7b have a cross-section comprising the attaching arm 10, the intruding section 11, and the box-type structure 12. In another embodiment, some section(s) of length of the sub frame 7a, 7b is/are exclusive of at least one of the attaching arm 10 and the intruding section 11.

[0028] The box-type structure 12 comprises walls 13 and corners 14 constituting a closed or partly open construction. The box-like structure 12 extends from the attaching arm 10 and is arranged on the outer surface 8 or on the inner surface 9 of the insulation panel 2.

[0029] In an embodiment, the cross-section of the box-type structure 12 is an open structure. Some embodiments are shown in Figures 2a and 2b. An advantage is that the structure is easy and simple to manufacture.

[0030] In another embodiment, the cross-section of the box-type structure 12 is a closed structure. Some embodiments are shown in Figures 2c - 2h. An advantage is that the structure may carry high loads.

[0031] In an embodiment of the closed structure, the box-type structure 12 is closed by a glue layer 22, a welded joint 23 and/or a fixing element 24. The fixing element 24 may be e.g. a screw, a rivet, etc.

[0032] In an embodiment, the box-type structure 12 comprises at least three corners 14 when seeing from the end thereof. In an embodiment, the box-type structure 12 comprises at least four corners 14 when seeing from the end thereof. In an embodiment, the box-type structure 12 comprises at least five corners 14 when seeing from the end thereof. An advantage is that the more corners, the higher is the stiffness of the structure.

[0033] In an embodiment, the attaching arm 10 is straight when seeing from the end thereof. In another embodiment, the attaching arm 10 comprises at least one bend 5 when seeing from the end thereof, and the edge surface 6a, 6b of the insulation panel respective shapes adapted to the shape of the attaching arm 10, and the bend 5 may comprise e.g. at least three corners. In another embodiment, the attaching arm 10 comprises corrugations. Advantages of these embodiments are that the stiffness is increased and more surface for gluing created.

[0034] The corners 14 and bends 5 stiffens the structure of the building system 100. Additionally, they may form tongue- and-groove-type attaching means in connections of two elements 1.

[0035] In an embodiment, the intruding section 11 is arranged at the distal end of the attaching arm 10. An advantage is that as the distance to the box-type structure 12 is maximized, and the stiffness of the element 1 may be optimized.

[0036] In an embodiment, the intruding section 11 is arranged in angle (A) of 90° in the attaching arm 10. An advantage is that the intruding section 11 is simple to push in the material of the insulation panel, and also strength of the element may be increased.

[0037] In an embodiment, the intruding section 11 comprises corrugations. An advantage is that the stiffness is increased and more surface for gluing created.

[0038] **Figures 3a - 3g** are schematic top views of embodiments of connecting elements of the arrangement.

[0039] The connecting element 4 is at least essentially as long as the sub-frame 7a, 7b. In an embodiment, the length of the connecting element 4 is at least 80 % of the length of the sub-frame 7a, 7b. The connecting element 4 has a cross-section comprising two arms 15a, 15b and a connecting section 16 connecting said two arms, the cross-section having basically a shape of a U-profile. The connecting element 4 keeps together said sub-frames 7a, 7b of adjacent elements 1.

[0040] The width of the connecting element 4 is dimensioned such that it may be attached on two adjacent sub-frames 7a, 7b. In an embodiment, said width is in range of 150 - 350 mm.

[0041] The depth of the connecting element 4 is dimensioned such that the arms 15a, 15b admit of a proper attachment of the sub-frames 7a, 7b. In an embodiment, the depth is in range of 30 - 150 mm.

[0042] According to an aspect of the invention, the connecting element 4 consists of one connecting-component 17, shown in Figure 1, the length of which is at least essentially equal to the height of sub-frame 7a, 7b. An advantage is that a very sturdy combination of the sub-frames and the connecting element may be achieved.

[0043] According to another aspect of the invention, the connecting element 4 consists of plurality of connecting-components 17 that, in use, are arranged successively on the sub-frames 7a, 7b of the two adjacent elements 1. An advantage is that handling of the shorter connecting-components may be easier.

[0044] In an embodiment, there are one or more second connecting elements 20 that, in use, are arranged on the connecting element(s) 4, thus creating a multi-layered structure of connecting elements. An advantage is that the structure may be tailored easily to the requirements of the building.

[0045] In an embodiment, the sub-frame 7a, 7b and the connecting element 4, and the second

connecting elements 20, if any, comprise openings 21, shown in Figure 1, that constitute, in use, a cross-wise passage there through. An advantage is that any cables, pipes, ducts for functions needed in the building may be arranged easily in the building system.

[0046] In an embodiment, the connecting element 4 comprises a sloping 26 arranged at the free end of at least one of the arm 15a, 15b. An advantage is that the mounting of the connecting element may be facilitated.

[0047] According to an aspect, the connecting element 4 creates with the sub-frames 7a, 7b a sandwich structure that prevents efficiently twisting and buckling typical for metallic profiles.

[0048] **Figure 4** is a schematic top view of an assembly method step of the arrangement.

[0049] In the method for constructing a building, there are connected plurality of prefabricated elements 1 described in this description and created thus a demanded wall, floor, roof or ceiling of the building.

[0050] According to an aspect, when building a wall, the building system 100 comprises a transversal bottom element 27 shown in Figure 1, on which the prefabricated elements 1 are erected. In an embodiment, the bottom element is a steel L-profile. The bottom element is preferably dimensioned such that it does not extend to the plane of the outer surface 8 of the insulation panel 2. Thus, the insulation properties of the element 1 may be maintained.

[0051] The building system 100 may also comprise a transversal upper frame member 28 arranged on top of the box-type structure 12, and in some cases, also on the attaching arm 10 and the intruding section 11. The upper frame member 28 may be e.g. steel L-profile, and dimensioned according to the same principles as described above in connection with the bottom element.

[0052] In the method two prefabricated elements 1 are connected by contacting their opposite edge surfaces 6a, 6b to each other. Then, the sub-frames 7a, 7b of said prefabricated elements 1 are attaching to each other. In an embodiment, the sub-frames 7a, 7b are attached to each other by a glue layer 22. An advantage is that the structure is even more stiff and strong.

[0053] Glue used in the glue layer 22 may be e.g. silyl modified polymer (SMP).

[0054] The glue layer 22 may also be arranged in a flap element, such as a tape, on one or both surfaces thereof. The flap element may have a soft and/or elastic base layer. In an embodiment, the flap element covers all the contacting surfaces between the sub-frames 7a, 7b. The contacting surfaces between the elements 1 not having the flap element may be provided with a foam layer that is fed from outer surface 8 side of the system.

[0055] The glue layer 22 may be arranged on all contacting surfaces where the sub-frames

7a, 7b meet each other. In another embodiment, there are selected sub-areas that are covered by the glue layer 22. Also fixing elements 24, such as screws, may be used alone or together with glue for attaching the sub-frames 7a, 7b to each other. Following connection of the sub-frames 7a, 7b, or following their attaching, the connecting element 4 is arranged on said sub-frames 7a, 7b, and attached thereto.

[0056] In an embodiment, the connecting element 4 is attached to the sub-frames 7a, 7b by a glue layer. Also here the glue may comprise e.g. silyl modified polymer (SMP). Also fixing elements, such as screws, may be used here, alone or together with glue.

[0057] The stiff insulation panels 2 support and prevent deformations of the sub-frames 7a, 7b, and thus the prefabricated elements 1 stands well even excess loads.

[0058] In an embodiment, the cross-section of the box-type structure 12 comprises a first projecting section 18 that extends sideways in direction of the surface 9, 10 of the insulation panel and arranged at a distance from said surfaces. Furthermore, the first projecting section 18 is arranged on surface of the box-type structure 12 facing away from the edge surface 6a, 6b wherefrom the attaching arm 10 is extending. Similarly, the connecting element 4 comprises second projecting sections 19 that are arranged to fit in the shape first projecting sections 18 of sub-frames 7a, 7b. Co-operation of the first and second projecting sections 18, 19 creates a shape-based locking system between said two sub-frames 7a, 7b and the connecting element 4. An advantage is that the correctness of the fitting between the sub-frames and the connecting element may be easily detected.

[0059] The invention is not limited solely to the embodiments described above, but instead many variations are possible within the scope of the invention defined by the claims below. Within the scope of the invention the attributes of different embodiments and applications can be used in conjunction with or replace the attributes of another embodiment or application. The drawings and the related description are only intended to illustrate the invention. The invention may vary in detail within the scope of the invention defined in the following claims.

REFERENCE SYMBOLS

[0060]

- 1
prefabricated element
- 2
insulation panel
- 3
metal frame
- 4
connecting element

- 5
bend
- 6a, b
edge surface
- 7a, b
sub-frame
- 8
outer surface
- 9
inner surface
- 10
attaching arm
- 11
intruding section
- 12
box-type structure
- 13
wall
- 14
corner
- 15a, b
arm of connecting element
- 16
connecting section
- 17
connecting-component
- 18
first projecting section
- 19
second projecting section
- 20
second connecting element
- 21
opening
- 22
glue layer
- 23
welded joint
- 24
fixing element
- 25
auxiliary profile
- 26
sloping

27	bottom element
28	upper frame member
100	building system
A	angle between attaching arm and intruding section

REFERENCES CITED IN THE DESCRIPTION

Cited references

This list of references cited by the applicant is for the reader's convenience only. It does not form part of the European patent document. Even though great care has been taken in compiling the references, errors or omissions cannot be excluded and the EPO disclaims all liability in this regard.

Patent documents cited in the description

- [US3282613A \[0005\]](#)

P A T E N T K R A V

1. Byggesystem til konstruktion af en bygning, hvilket system (100) omfatter:

- en flerhed af præfabrikerede elementer (1), elementet (1) omfatter:

5 -- et selvbærende isoleringspanel (2), som omfatter et rigidt isoleringsmateriale og har to lige og parallelle kantflader (6a, 6b) og en ydre og indre overflade (8, 9),

-- en metalramme (3) omfattende et par af underrammer, en første underramme (7a) fastgjort til en første kantflade (6a) og en anden underramme (7b) fastgjort til en anden kantflade (6b) af isoleringspanelet (2),

-- underrammen (7a, 7b) udstrækker sig langs længden af isoleringspanelet,

- længden af underrammen (7a, 7b) har et tværsnit omfattende

10 --- en fastgørelsesarm (10), der udstrækker sig langs den tilsvarende kantflade (6a, 6b), og

--- en indtrængende sektion (11) anbragt i fastgørelsesarmen (10) og i en vinkel i forhold til denne, hvilken indtrængende sektion (11) trænger ind i isoleringspanelet (2), og

--- en kasselignende struktur (12) anbragt distalt fra den indtrængende sektion (11) og omfattende vægge (13) og hjørner (14), der udgør en lukket eller delvis åben konstruktion,

15 --- hvor den kasselignende struktur (12) udstrækker sig fra fastgørelsesarmen (10) og er anbragt på den ydre overflade (8) eller på den indre overflade (9) af isoleringspanelet (2),

hvor byggesystemet omfatter yderligere

- et forbindelseselement (4), der er i det mindste i det væsentlige er lige så lang som underrammen (7a, 7b) og har et tværsnit omfattende to arme (15a, 15b) og en forbindelsessektion (16), der forbinder de to arme,

20 hvor tværsnittet grundlæggende har form som et U-profil, idet forbindelseselementet (4), i brug, er anbragt på underrammerne (7a, 7b) af to tilstødende elementer (1), hvilke arme (15a, 15b) er anbragt på modsatte sider af de to underrammer (7a, 7b) og holder underrammerne (7a, 7b) af de tilstødende elementer (1) sammen.

25 2. Byggesystem ifølge krav 1, hvor isoleringspanelet (2) er et termisk isoleringspanel som omfatter mindst et af følgende opskummede materialer: polyisocyanurat (PIR), polyurethan (PUR) og ekstruderet polystyren (XPS).

30 3. Byggesystem ifølge et hvilket som helst af de foregående krav, hvor forbindelseselementet (4) består af en forbindelseskomponeent (17), hvis længde i det mindste i det væsentlige er lig med længden af isoleringspanelet (2).

35 4. Byggesystem ifølge et hvilket som helst af de foregående krav, hvor i det væsentlige hele længden af underrammen (7a, 7b) har et tværsnit omfattende fastgørelsesarmen (10), den indtrængende sektion (11), og den kasselignende struktur (12).

5. Byggesystem ifølge et hvilket som helst af kravene 1-4, hvor fastgørelsesarmen (10) omfatter mindst én bøjning (5) set fra enden deraf, og isoleringspanelets kantflades (6a, 6b) respektive former er tilpasset formen af fastgørelsesarmen (10).

6. Byggesystem ifølge et hvilket som helst af de foregående krav, hvor den indtrængende sektion (11) er anbragt ved den distale ende af fastgørelsesarmen (10).

5 7. Byggesystem ifølge et hvilket som helst af de foregående krav, hvor tværsnittet af den kasselignende struktur (12) er en lukket konstruktion, idet den kasselignende struktur (12) fortrinsvis er lukket af mindst én af de følgende: et limlag (22), en svejset samling (23) og et fikseringselement (24).

10 8. Byggesystem ifølge et hvilket som helst af de foregående krav, hvor den kasselignende struktur (12) omfatter mindst tre hjørner (14) set fra enden deraf.

9. Byggesystem ifølge et hvilket som helst af de foregående krav, hvor forbindelseselementet (4) består af en forbindelseskomponent (17), hvis længde i det mindste i det væsentlige er lig med højden af underrammen (7a, 7b).

15 10. Byggesystem ifølge et hvilket som helst af de foregående krav, hvor tværsnittet af den kasselignende struktur (12) omfatter en første udragende sektion (18), der udstrækker sig sideværts i retningen af overfladen (9) af isoleringspanelet (2) og er anbragt i en afstand fra overfladen (9), idet den første udragende sektion (18) er rettet væk fra kantfladen (6a, 6b), hvorfra fastgørelsesarmen (10) udstrækker sig, og

20 forbindelseselementet (4) omfatter andre udragende sektioner (19), der under brug er indrettet til at passe i formen af de første udragende sektioner (18) af underrammerne (7a, 7b) af de to tilstødende elementer (1), for således at lave et låsesystem mellem de to underrammer (7a, 7b) af de to tilstødende elementer (1).

25 11. Byggesystem ifølge et hvilket som helst af de foregående krav, hvor underrammen (7a, 7b) er fastgjort til isoleringspanelet (2) med et limlag (22).

12. Byggesystem ifølge et hvilket som helst af de foregående krav, hvor underrammene (7a, 7b) af to tilstødende elementer (1) er fastgjort til hinanden med et limlag (22).

30 13. Byggesystem ifølge et hvilket som helst af de foregående krav, hvor fastgørelseselementer (24) også er anbragt for at fastgøre underrammerne (7a, 7b) eller underrammerne (7a, 7b) og forbindelseselementet (4).

35 14. Byggesystem ifølge et hvilket som helst af de foregående krav, hvor, der under brug, er fastgjort mindst et hjælpeprofil (25) til det præfabrikerede element (1) mellem to underrammer (7a, 7b).

15. Fremgangsmåde til at konstruere en bygning, hvilken fremgangsmåde omfatter:

- at forbinde to præfabrikerede elementer (1), som dem defineret i et hvilket som helst af de foregående krav, ved at bringe deres modstående kantflader (6a, 6b) i kontakt med hinanden,
- at fastgøre underrammerne (7a, 7b) af de præfabrikerede elementer (1) til hinanden,

- at anbringe forbindelseelementet (4), der er defineret i et hvilket som helst af de foregående krav, på underrammerne (7a, 7b), og

- at fastgøre forbindelseelementet (4) til underrammerne (7a, 7b).

DRAWINGS

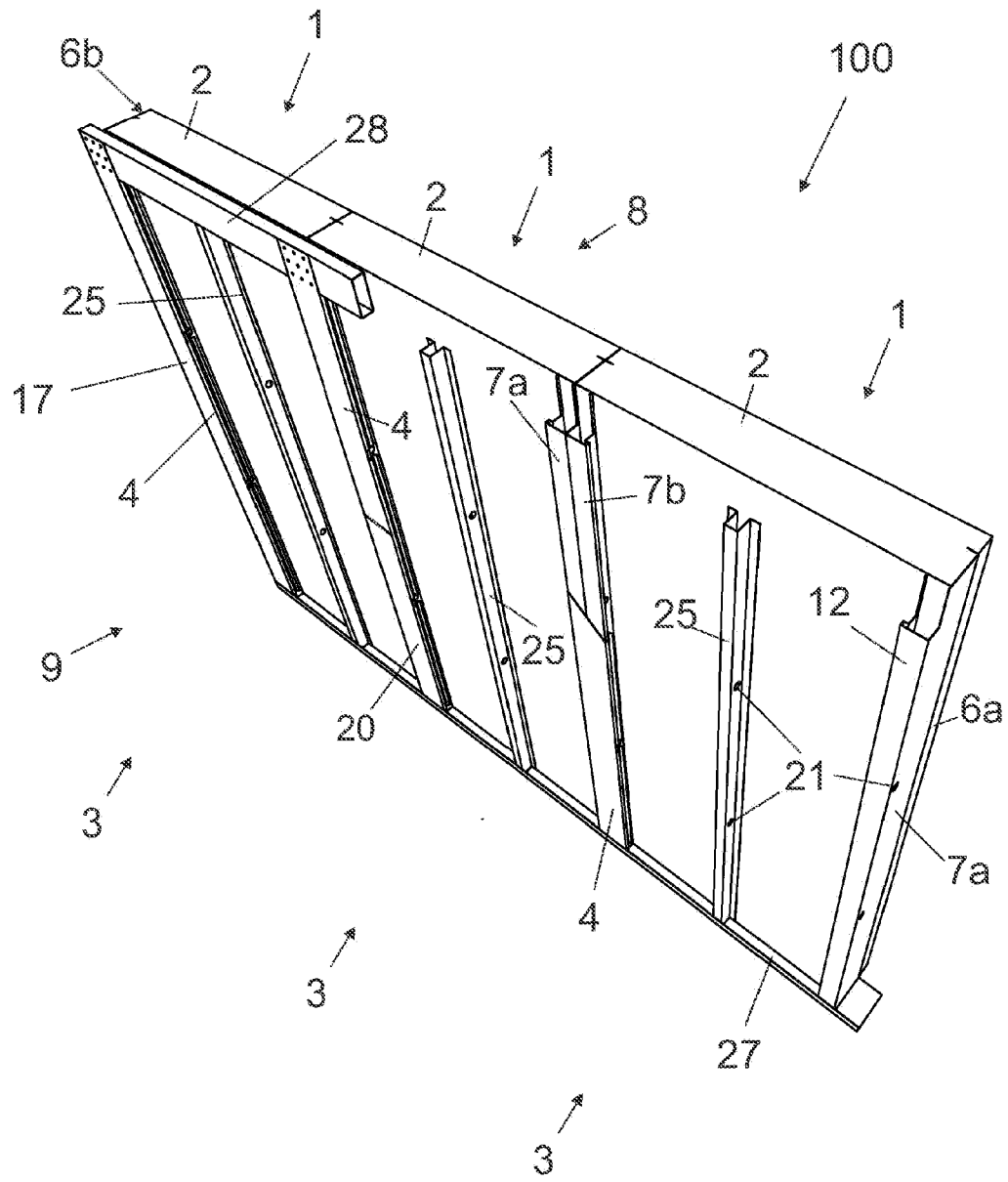

Fig. 1

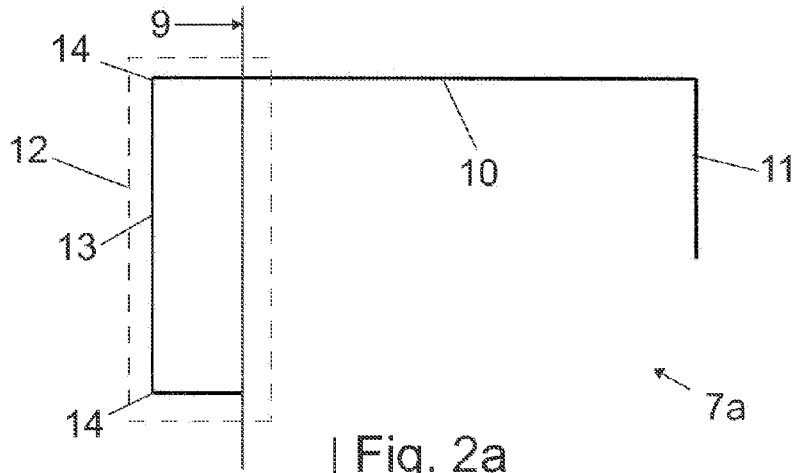

Fig. 2a

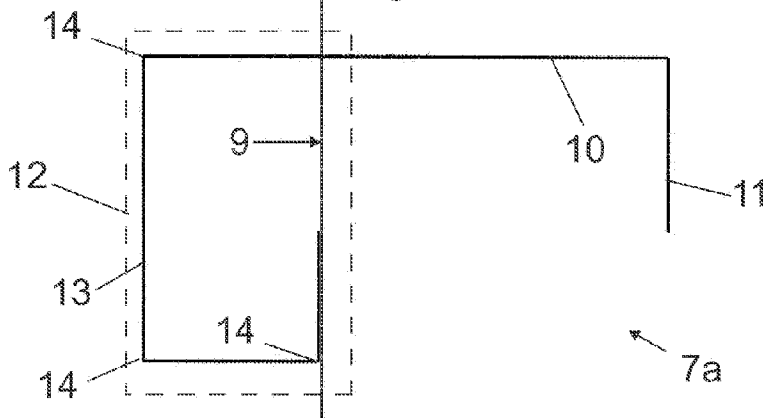

Fig. 2b

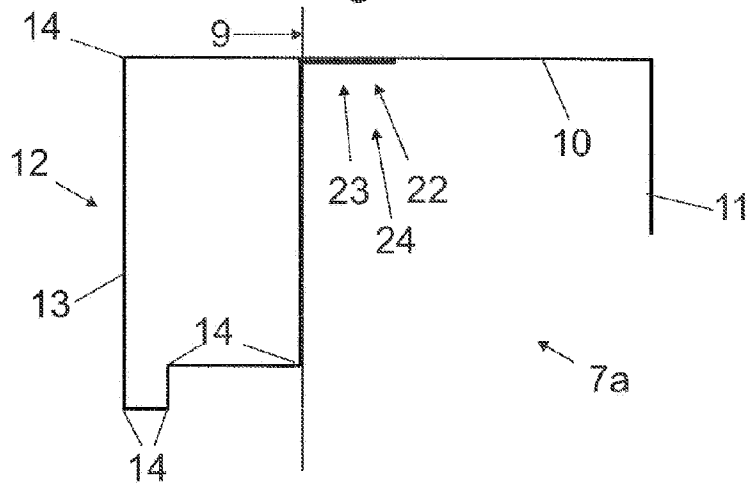

Fig. 2c

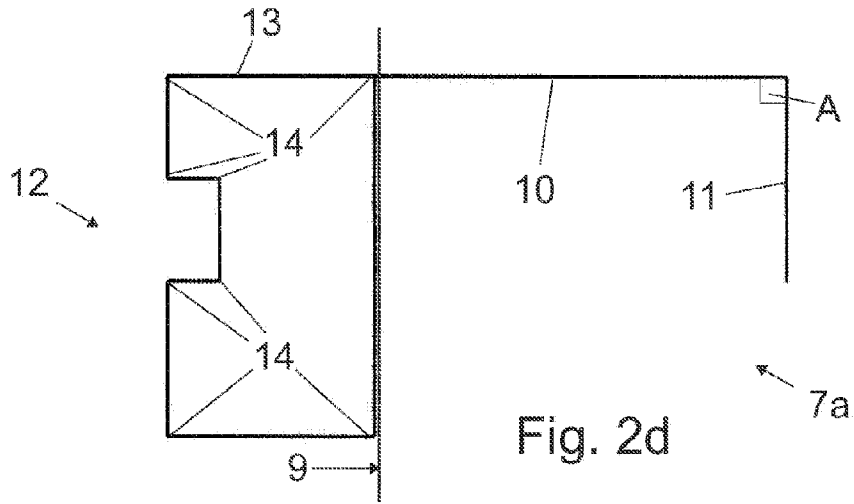

Fig. 2d

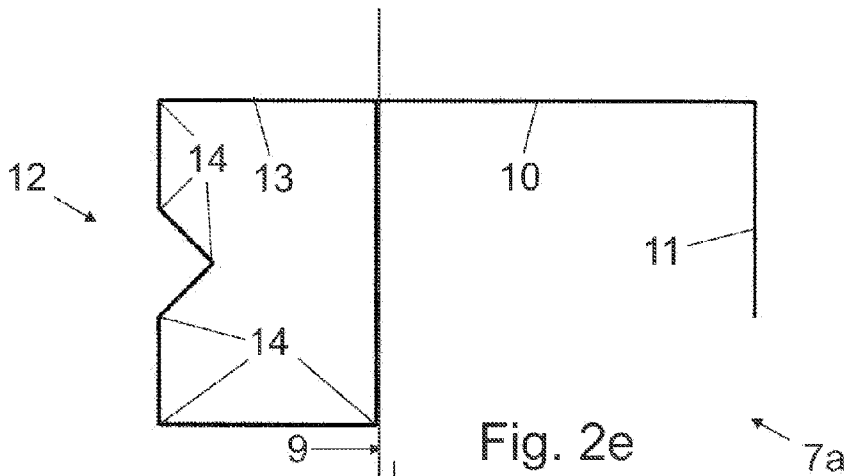

Fig. 2e

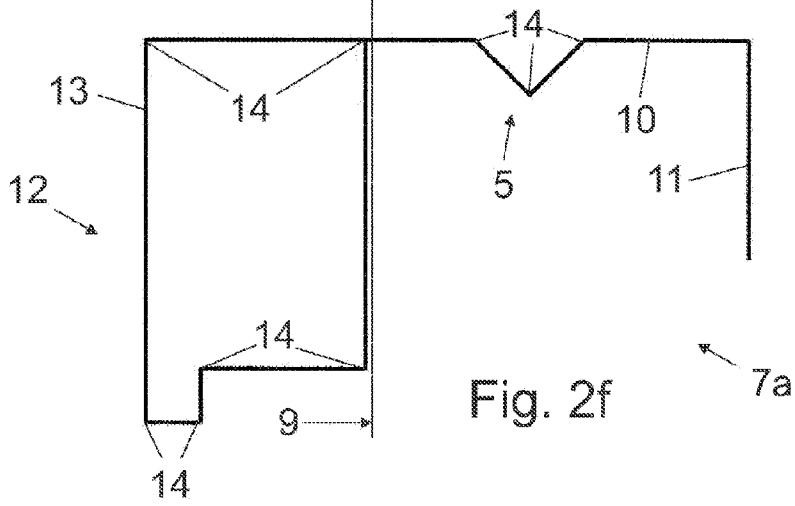

Fig. 2f

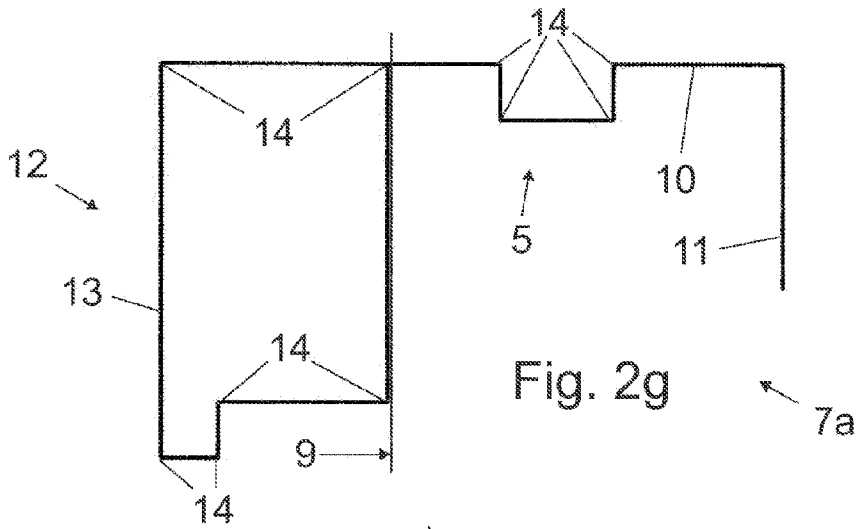

Fig. 2g

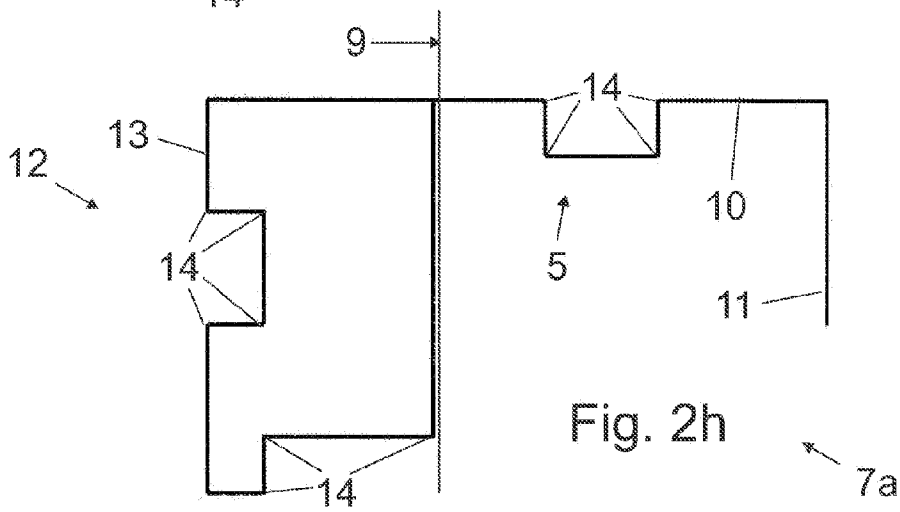

Fig. 2h

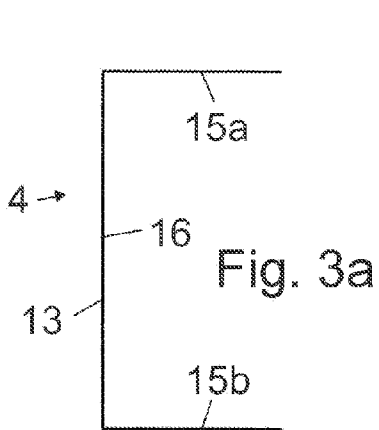

Fig. 3a

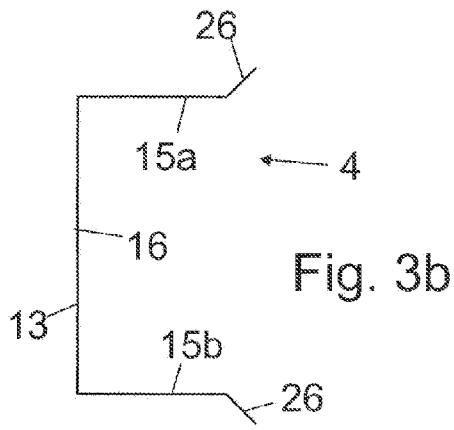

Fig. 3b

