

[54] COLLAPSIBLE MULTI-COMPARTMENT CONTAINER

[75] Inventor: Jean Roussel, Caluire, France

[73] Assignee: SCAL, Societe de Conditionnements en Aluminium, Paris, France

[22] Filed: Jan. 17, 1972

[21] Appl. No.: 218,416

[30] Foreign Application Priority Data

Jan. 18, 1971 France ..... 7101528

[52] U.S. Cl. .... 229/51 DB, 229/27, 229/17 G, 206/56 AB

[51] Int. Cl. .... B65d

[58] Field of Search ..... 229/27, 28, 51 DB, 229/56; 206/56 AB, 45.11

[56] References Cited

UNITED STATES PATENTS

1,035,258	8/1912	Stegman .....	229/51 DB UX
1,998,147	4/1935	Stegman .....	229/51 DB UX

2,993,632	7/1961	De Feo .....	229/27
3,295,739	1/1967	Wilcox .....	229/17 G
3,204,850	9/1965	Wilcox .....	229/17 G
471,255	3/1892	Lorenz .....	229/56

FOREIGN PATENTS OR APPLICATIONS

3,001	10/1890	Sweden .....	229/56
-------	---------	--------------	--------

Primary Examiner—Davis T. Moorhead  
Attorney—McDougall, Hersh & Scott

[57] ABSTRACT

A collapsible multi-compartment container having a plurality of prismatic compartments and adapted to lie flat when empty, formed of a pair of superposed panels joined to each other along their transverse edges and at regular intervals in a direction substantially perpendicular to the longitudinal edges, at least one fold line extending across the width of the panels and at least one fold line extending along at least the longitudinal edge of each panel to define continuous strip means adapted to form closure flaps for each compartment.

8 Claims, 12 Drawing Figures

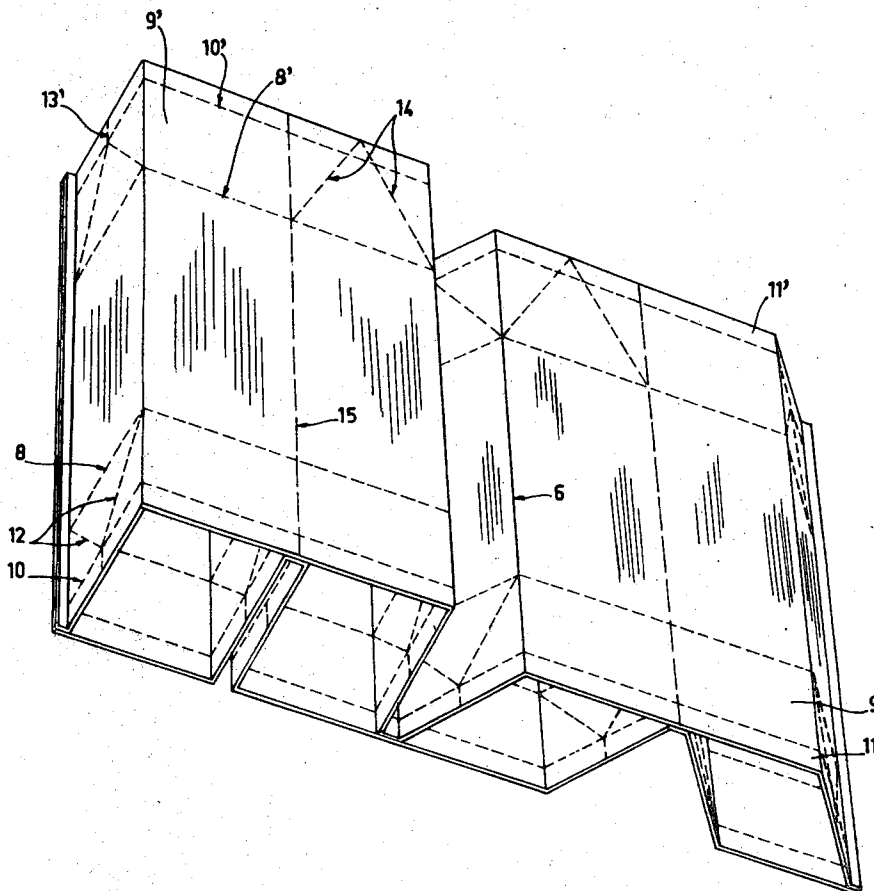

Fig. 1

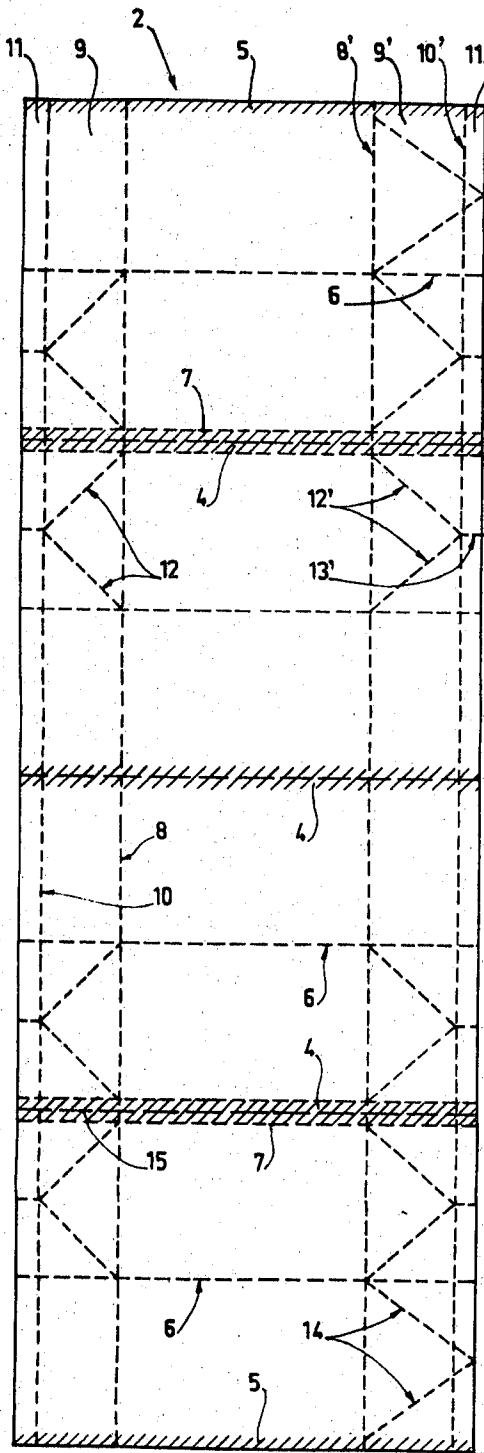

Fig. 2

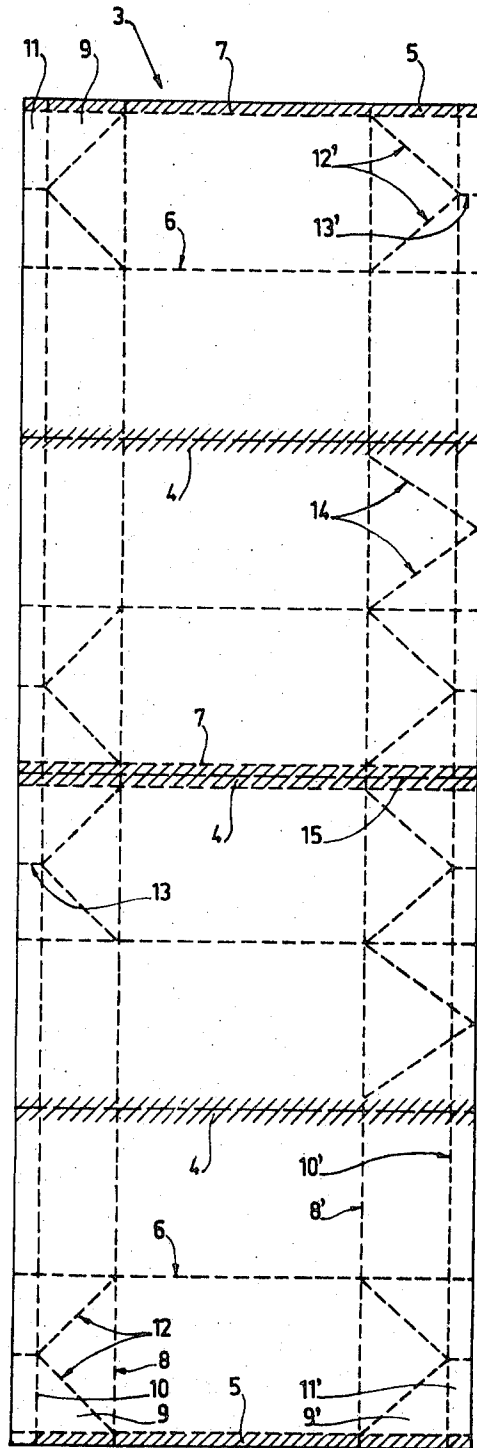

Fig. 5

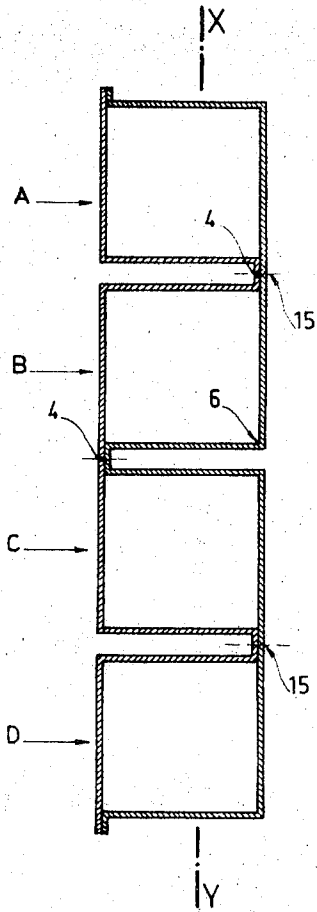

Fig. 4

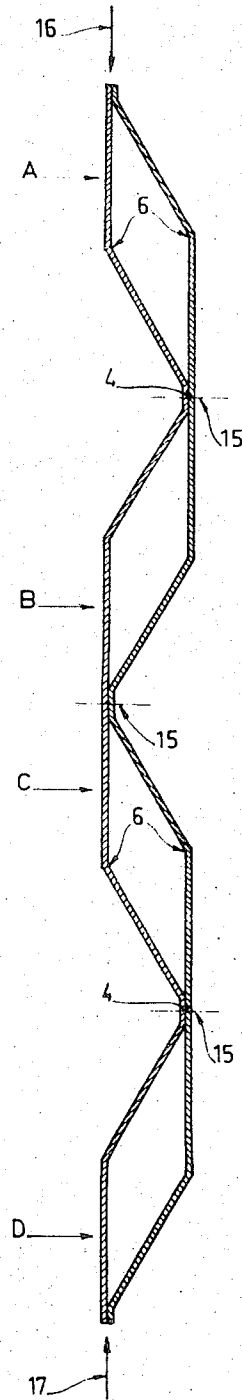

Fig. 3

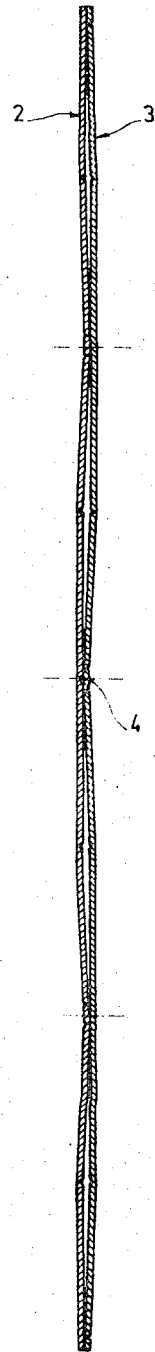



Fig. 6

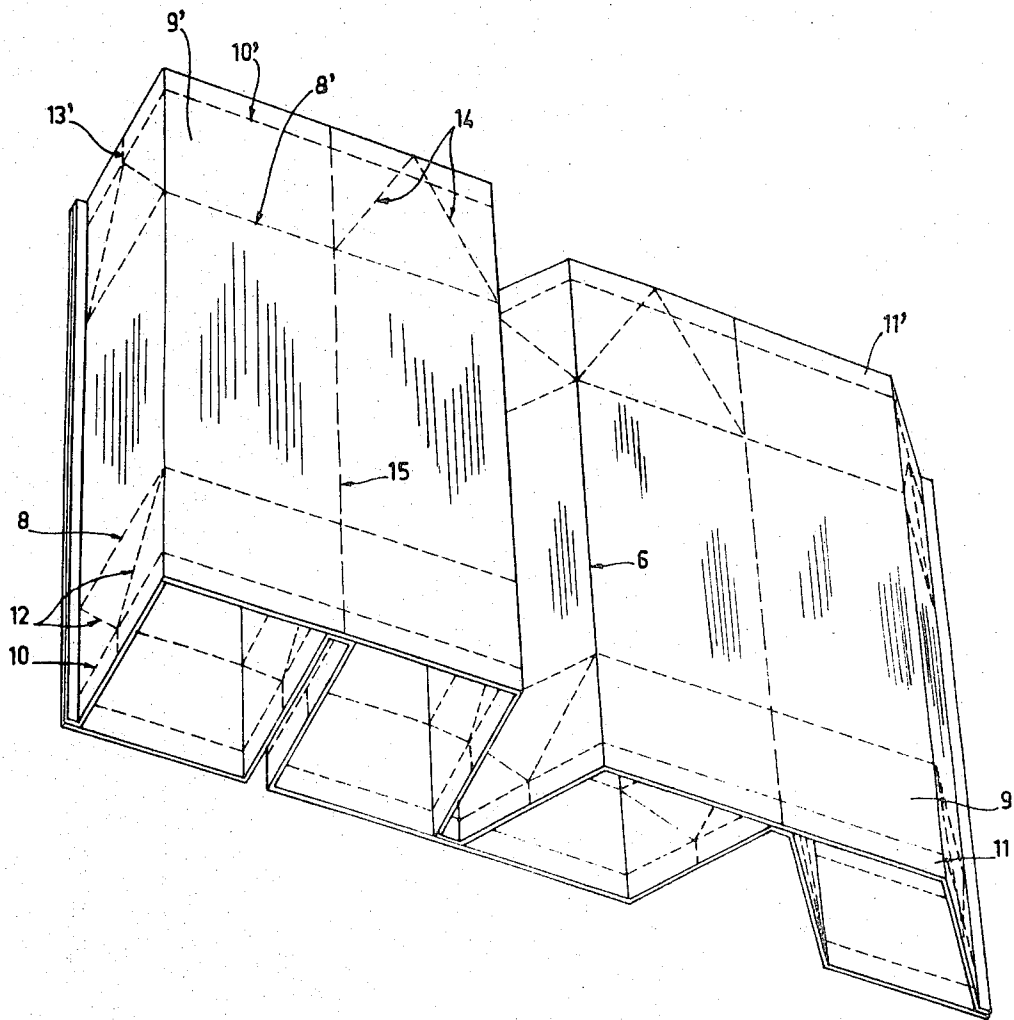

Fig. 8

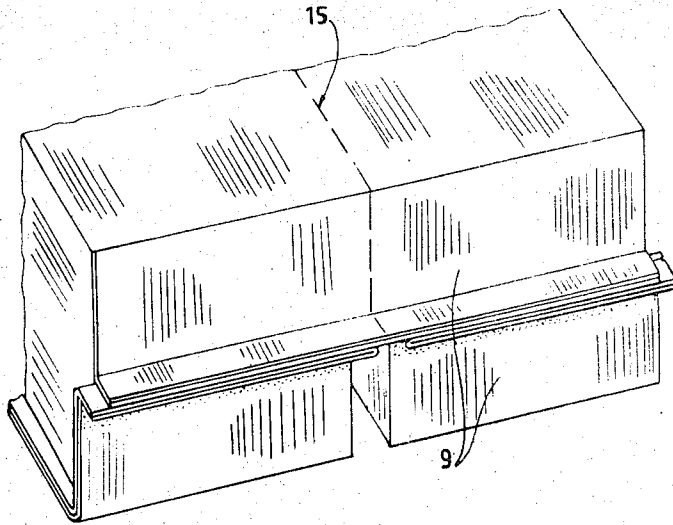

Fig. 9

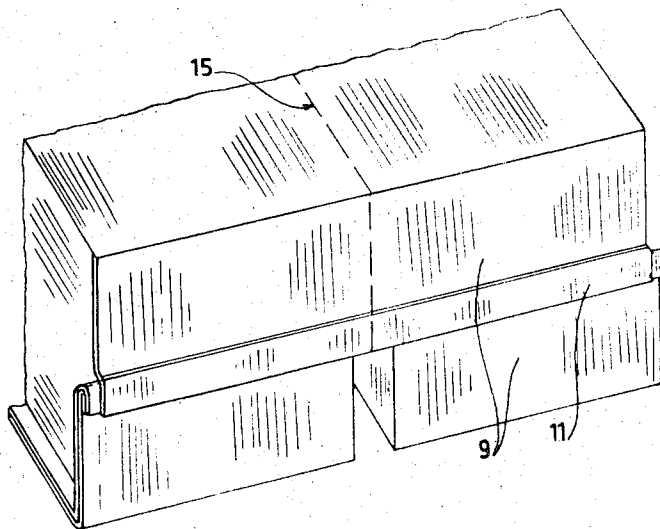

Fig. 10

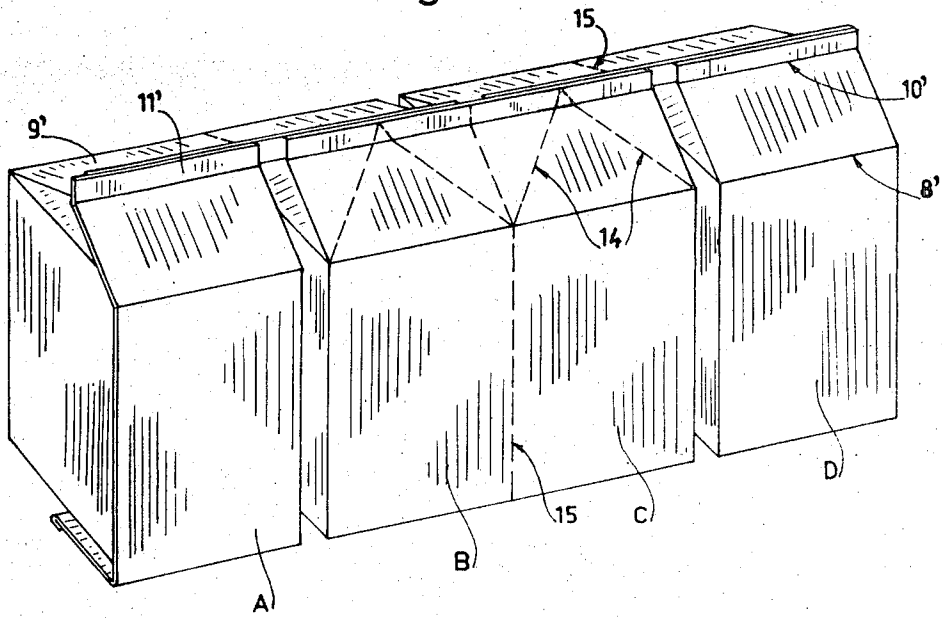

Fig. 11

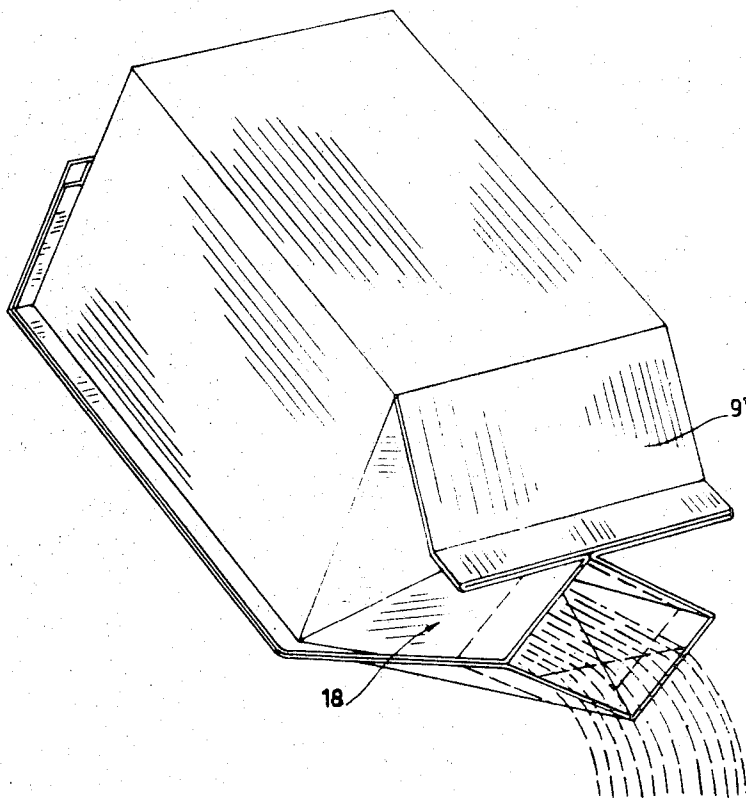
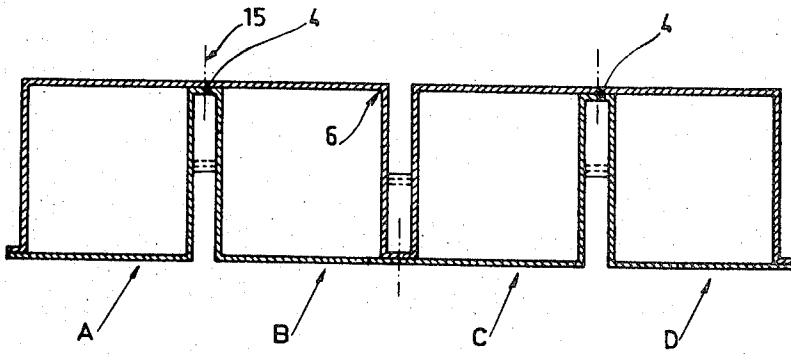

Fig. 12



## COLLAPSIBLE MULTI-COMPARTMENT CONTAINER

This invention relates to a one-piece container of semi-rigid material which comprises prismatic compartments and which is designed to be delivered flat to the consumer.

Due to the progress which has been made in the preservation or conservation of foodstuffs, the habits of consumers are undergoing a considerable change. There is a distinct tendency among consumers to buy enough provisions for several days, even for one week at a time, and the labor-saving handling of foodstuffs is important, especially in shops of the self-service kind.

Industry has responded to this new need by grouping individual containers into block packages. However, this answer leaves unresolved a number of problems in the route of the container from the manufacturer to the consumer via the conserver and the retailer.

In cases where the individual container is rigid, as in the case of a bottle, for example, delivery and storage of the empty container have to be carried out under un-economic conditions. In the case of a flexible individual container, the block package must of necessity be rigid, so that its cost is relatively high in comparison with that of the conserved product.

In addition, the block packages often have fairly large overall dimensions in relation to their capacity and thus occupy a disproportionate amount of space which could otherwise be effectively used both by the consumer and by the retailer who has to provide fairly large display stands.

Simple block packages in the form of a removable tubular plastics wrapping do not have this disadvantage. However, they do have the disadvantage that, once the wrapping has been removed, the individual containers are scattered.

According to another known proposal, one-piece multi-compartment containers are made by heat-forming open cells in a sheet of plastics material and blocking the openings of the cells with a removable film. Unfortunately, the volume of these cells prevents the empty container from being economically stored and transported. In addition, the rate at which these containers can be produced is relatively low.

It is accordingly an object of the invention to provide a container for foodstuffs and the like which can be manufactured in a simple and economical manner at high production rates from materials commercially used for containers for foods.

It is a further object of the invention to provide a container for foodstuffs and the like which takes on a flat configuration when empty and can be delivered in the form of a preform cut to the required dimensions or in the form of an endless web wound onto a spool or a folded package having a plurality of individual compartments for use with automatic processing machinery.

It is yet another object of the invention to provide a container for foodstuffs and the like in the form of a one-piece structure having improved rigidity when assembled for use for easy handling by retailers, consumers, etc., and which is capable of being separated into one or more individual containers without affecting the rigidity and integrity of the remaining compartments.

These and other objects and advantages of the invention will appear more fully hereinafter and, for pur-

poses of illustration, but not of limitation, embodiments of the invention are shown in the accompanying drawings in which:

FIG. 1 is a plan view of one of the panels used in the production of the container;

FIG. 2 is a plan view of the second panel intended to be joined to the first for forming the container;

FIGS. 3, 4 and 5 are cross-sections through the two joined panels and illustrate the initial stages in the formation of the container;

FIG. 6 is a perspective view of a container, partly prepared for the closing operation;

FIGS. 7, 8 and 9 illustrate several stages in the closure of the base;

FIG. 10 is a perspective view of a closed assembly;

FIG. 11 shows an individual compartment in use; and

FIG. 12 is a cross-section through the container after it has been made up.

The concepts of the invention reside in a one-piece container of semi-rigid material which comprises several prismatic compartments and which is designed to be delivered flat to the consumer. The container of the invention is formed by the superposition of two panels joined from one longitudinal edge to the other along connecting zones I, perpendicular to the aforementioned edges, situated at regular intervals each corresponding to half the perimeter of the base of a compartment, the interval between two consecutive connecting zones being provided over the entire width of each of the panels with at least one fold line II parallel to the aforementioned zones, while at least one other fold line III, defining a closure flap, is situated parallel to at least one edge of each panel. The individual panels can either be in the form of endless webs or in the form of web segments, and the following description applies equally to these two embodiments.

When, during closure of compartments that have been filled, the longitudinal edge or edges of the panels are folded back around the line III, that part of the connecting zone which extends from one edge of the joined panels to the line III is also folded and, in this way, forms a rigid connection between two consecutive compartments. The connecting zones I can be defined by fold lines. For each panel, it is sufficient for one out of the two connecting zones to be defined in this way. When the two panels are placed one on top of the other, a zone defined on one of them faces an undefined zone on the other. The fold line II situated between two connecting zones can be equidistant from these two zones. In this case, the individual compartments of the container will have a square base. To close each compartment, it is advantageous for each segment defined on the fold line III parallel to the longitudinal edge by the intersections of this line with the transverse fold lines II and with the edges of these zones, respectively, to form the base of an isosceles triangle whose other two sides are formed by fold lines extending towards the longitudinal edge and if necessary by the extension of these lines when the virtual point of intersection is situated outside the panels.

In the embodiment described, the fold lines situated outside the line III define panel sections which are folded down when the container is closed, alternately forming gussets and flaps. In addition, the fold lines which, as indicated above, form an isosceles triangle enable the flap to be opened in the form of a pouring spout.

The aforementioned fold lines are in the form of more or less deep grooves of the kind well known in the field of foldable containers.

To make the individual containers easier to separate, the connecting zones I are weakened longitudinally by a precut line.

At least those parts of the panels intended to be permanently joined together can be coated with a layer of heat-weldable material.

To facilitate a ready understanding of the description of the invention, the embodiment illustrated relates to a container which consists of four single compartments and which is formed from two panels of suitable dimensions. However, other panels and other designs, for example as regards the closures, will be apparent to those skilled in the art.

The two panels 2 and 3 shown in FIGS. 1 and 2 can consist of any material adapted to the contents, providing it can be folded and has a certain rigidity.

Accordingly, it is possible to use cardboard or sheets of a homogeneous, optionally expanded plastics material or composite materials. Thus, the cardboard can be covered with a film of plastic material such as polyethylene. A sheet of aluminum can be applied to the outside for aesthetic or functional reasons. Applied internally, the sheet of aluminum will in many cases afford special protection to the contents. All these layers are joined together by known methods.

The panels shown in FIGS. 1 and 2 comprise connecting zones 4 which are perpendicular to the longitudinal edges of the panels. Similar but generally narrower zones 5 are situated at the transverse edges. The interval between two connecting zones is equal to half the perimeter of the base of one of the individual compartments of the container according to the invention.

Each of the panels is provided with grooved lines which, during make-up of the container, are intended to facilitate unfolding of the preforms resulting from the joining of two panels, and folding down of the flaps which form the closure of the container.

Thus, between two connecting zones 4, 5, the panel is provided with a grooved folding line 6 parallel to these zones, i.e., perpendicular to the edges.

In the embodiment illustrated in the drawings, these grooves are situated at an equal distance from two assembly zones. The prismatic compartment arising out of this particular arrangement will have a square base. To obtain compartments with rectangular bases, it is sufficient to displace these lines on the two superimposed panels in the same ratio but in the opposite direction. In the following section extending up to a new assembly zone, these ratios are preferably inverted so that, after assembly, the two opposite sides of each individual container are equal.

The connecting zones 4, 5 can be defined by fold lines 7 parallel to the preceding fold lines 6. However, it is preferred to provide only one out of two zones with these grooves 7 so that, when two panels are placed one on top of the other, a zone defined by grooves on one of them corresponds to a non-defined zone on the other.

The object of the transverse grooves 6, 7 discussed in the foregoing is to facilitate formation of adjacent compartments. They are completed by longitudinal grooves which cooperate with the preceding grooves to close these tubes.

Starting with the lower part of the panels, a first grooved line 8 parallel to the side edge defines a foldable strip 9 in which the closure flaps and gussets will be formed. The width of this strip 9 is substantially equal to half one side of the base. A second grooved line 10 situated near and parallel to the edge defines a sealing strip 11. These two strips 9, 11 also comprise oblique grooves 12 which start from intersections between certain transverse grooves 6, 7 and the first groove 8 and which form isosceles triangles whose apex, in the embodiment shown, is situated on the groove 10 defining the sealing strip 11. Another groove 13 starts from this apex and is perpendicular to the edge.

The system of grooves shown in the drawing is the same in the upper part. Lines 8', 10', 12' and 13' correspond to the groove lines 8, 10, 12 and 13. In addition, this upper part comprises the grooves 14 forming other isosceles triangles whose base is formed by that part of the line 8' situated between the edges of one connecting zone 4 or 5 and the nearest transverse groove 6. The apices of these triangles are situated on the free edge of the panel.

The interval between the grooves 8' and 10' is greater than that provided in the base between 8 and 10. The effect of this enlargement of the foldable strip 9' is that the formation of the closure of the filling opening assumes the form of a ridge.

Finally, the connecting zones 4 are provided with a weakening line 15 formed for example by dotted or slotted perforations situated parallel to and at an equal distance from the longitudinal edges of the aforementioned zones 4.

FIG. 3 shows the joining of two panels 2 and 3 for the formation of a preform. Those parts of the connecting zones which touch one another are joined by a method known per se. Thus, where the panels consist of thick paper or cardboard, these parts can be joined by glueing. In cases where composite sheets are used, in which case that surface coming into contact with the contents consists of a plastics material (for example a polyolefin film), joining can be carried out by heat-welding or sealing, ultrasonic welding or by any other known method.

In order to align the preform before the container is filled, pressure is applied to the two transverse edges thereof in the direction of the arrows 16, 17 shown in FIG. 4. This pressure makes the elements assume a form whose cross-section comprises a sequence of four diamonds A, B, C, D which end up by being converted into squares as shown in FIG. 5.

It can be seen from this Figure that the connecting zones are situated alternately on either side of the central plane  $x-y$  extending through the four individual compartments. The individual compartments are thus aligned and joined together.

Before filling, the individual compartments as shown on the left hand side of FIG. 6 have to be closed on one side. For this purpose, the foldable strips 9 are folded down around the grooves 8, the sealing strips 11 being brought into contact with one another (FIGS. 7 and 8). By virtue of the grooves 14, gussets 18 are automatically formed.

The strips 11 are then joined by glueing, welding or any other suitable method which contributes to the tightness of the closure.

The ridge formed by the joining of these strips can be folded and fixed to the base (FIG. 9). The groove 8, in those segments where it forms the base of a triangle whose other sides are formed by the grooves 12, can be gently curved towards the interior of the panel which enables the container to stand on a flat base.

After the compartments thus prepared have been filled in the filling machine, the upper openings are closed in the same way as the base. The ridge formed by the joining of the strips 11' continues throughout the assembly.

The folding of the strips 9 and 9' leads to a result that is essential to the container according to the invention. The strips forming the connecting zones 4 are folded at their ends and thus form rigid connecting links between adjacent compartments. These connecting links are able without breaking to withstand considerable stressing of the kind encountered during handling of the container when the conditioned product is heavy.

Where the closure system used is different from that described above, for example where it is in the form of a flat closure obtained by complete folding of the lateral strips 9 and/or 9', cut beforehand in the form of foldable tabs, care should be taken to provide foldable strips wide enough for those parts of the zones 4 which are situated on these strips to be able to withstand these stresses, taking into account on the one hand the rigidity of the container material and on the other hand the weight of the contents.

In its assembled state, the one-piece multiple compartment container described above assumes a generally parallelepipedic form comprising a rear boundary wall and a front boundary wall formed by the alignment of the individual compartments of square cross-section. The rigidity of alignment is ensured by the connecting zones 4 described above, and particularly by those parts of these zones situated between the flaps of successive compartments.

As will be appreciated, the container according to the invention is particularly easy to manufacture and assemble.

In order to ensure perfect superposition of the zones to be joined, it can be of advantage to start with a double-width strip folded about its center line, rather than with the separate strips, in which case the edge is cut after two faces have been joined along the connecting zones.

It will be apparent that various changes and modifications can be made in the details of construction, assembly and use without departing from the spirit of the invention, especially as defined in the following claims.

I claim:

1. A one piece container formed of a substantially

rigid material which includes a plurality of prismatic compartments and which is adapted to lie flat when empty, comprising a pair of panels, one of which is superposed on the other, said panels being joined each to the other along their transverse edges and at regular intervals to define connecting zones in a direction substantially perpendicular to the longitudinal edges and extending over the entire width of the panels, with the intervals corresponding to half the perimeter of the base of one compartment, fold lines extending across the width of the panels between connecting zones and at least one fold line extending along at least one longitudinal edge of each panel to define continuous strip means adapted to form closure flaps for each compartment, a plurality of individual compartments of substantially parallelepipedic configuration comprising a front wall and a rear wall formed by folding each of the panels along the fold line extending across the width of the panels and along the connecting zones, with the front and rear walls being held in rigid alignment by the connecting zones alternately in front of and behind a central plane extending through the compartments.

2. A container as defined in claim 1 wherein the panels are joined to each other at regular intervals over a narrow distance to define a connecting zone substantially perpendicular to the longitudinal edges of the panels.

3. A container as defined in claim 2 wherein the connecting zone is defined by a pair of fold lines.

4. A container as defined in claim 2 wherein the fold line extending across the width of the panel is equidistant from adjacent connecting zones.

5. A container as defined in claim 2 wherein the continuous strip means includes at least a pair of fold lines defining the equal sides of an isosceles triangle extending toward the edge of each panel, with the base of each triangle being formed by a segment defined by the intersection of the connecting zone and the fold line extending across the width of the panel with the fold line extending along the longitudinal edge of each panel.

6. A container as defined in claim 2 wherein the connecting zone includes a precut line formed of perforations extending across the width of the panel to enable one compartment to be detached from adjacent compartments.

7. A container as defined in claim 1 wherein at least the portions to be joined together are covered with a layer of a heat-sealable material.

8. A container as defined in claim 2 wherein the fold lines extending across the width of one panel are aligned with the connecting zones of the other panel.

\* \* \* \* \*

55

60

65