

F. J. Staley.

Head Block for Saw-Mills.

N^o 110,085.

Patented Dec. 13, 1870.

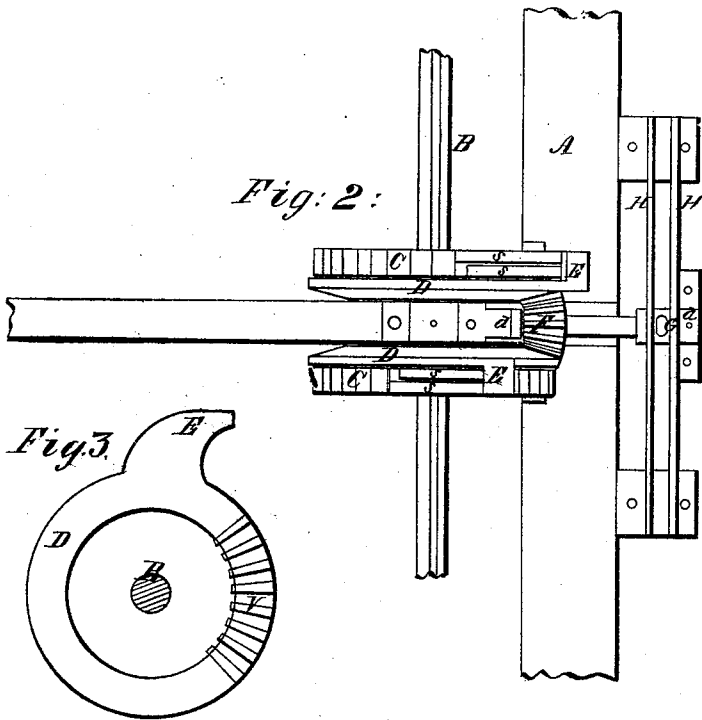
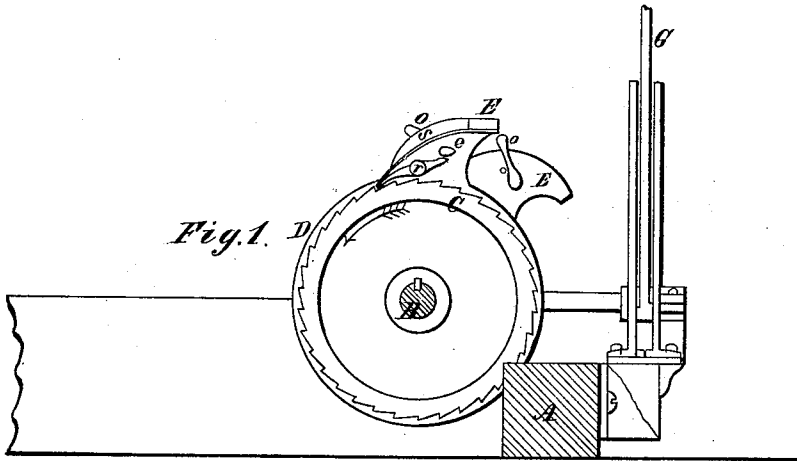

Witnesses:

*O. F. Mayhew.
G. A. Skinner*

Inventor:

Franklin J. Staley

UNITED STATES PATENT OFFICE.

FRANKLIN J. STALEY, OF INDIANAPOLIS, INDIANA, ASSIGNOR TO LONG,
JOSEPH & CARTER, OF SAME PLACE.

IMPROVEMENT IN HEAD-BLOCKS FOR SAW-MILLS.

Specification forming part of Letters Patent No. **110,085**, dated December 13, 1870; antedated
December 9, 1870.

To all whom it may concern:

Be it known that I, FRANKLIN J. STALEY, of Indianapolis, in the county of Marion and State of Indiana, have invented certain Improvements in Devices for Operating the Setting-Shaft of Saw-Mill Head-Blocks, of which the following is a specification.

My invention relates to device for operating the setting-shaft of saw-mill head-blocks; and it consists in the arrangement of two ratchet-wheels that are keyed on the setting-shaft, combined with two reciprocating rotary disks, being each provided with an arm having pawls to engage with the ratchet-wheels, and a segmental cog-bar. A pinion gears with the segmental cog-bar, and a lever attached to the pinion-shaft serves to operate the disks and pawls, and the latter rotate the ratchet-wheels and setting-shaft, which is connected with the head-blocks in any suitable manner.

The objects of the invention are to secure a nicer adjustment of the knees with equal rapidity and greater ease than heretofore with a simpler and cheaper device.

In the accompanying drawings, Figure 1 is a top view of the device embodying my invention. Fig. 2 is an end view of the same.

A is the outside timber of the log-carriage. B is the longitudinal setting-shaft, which has its bearings in brackets attached to the head-blocks in the usual manner. C C are ratchet-wheels keyed to the shaft B. D are disks or plates, made a little larger than the ratchets, and furnished with arms E, to which pawls *r* are attached to gear with the ratchets. These disks rotate freely on shaft B, and are furnished with segmental cogs, with which the pinion F gears, as shown. The shaft of pin-

ion F has its bearings at *a a*. By means of a lever, G, attached to the shaft of pinion F, the latter may be given a reciprocating rotary motion, and this, in turn, imparts a similar movement to the disks D, with their arms E and pawls *r*, and the latter, engaging with the ratchets C, rotate them and shaft B in the direction indicated by the arrows in Fig. 1. The movement of the lever in either direction rotates the setting-shaft constantly in the same direction. The pawls are held to the ratchets by springs S. When it becomes necessary to turn the setting-shaft backward, the pawls are disengaged by means of the cam *e*, which is operated by means of the lever *o*. The stroke of the lever G is regulated by pins in the semi-circular guides H in the usual manner.

This device is applicable to the setting-shaft when the latter is connected with the ordinary screw-head blocks or with the head-block, for which Letters Patent were issued to me December 21, 1869, or any similar arrangement.

The advantages of this device consist in the direct application of the ratchets to the setting-shaft, by which much of the gearing heretofore used is dispensed with, and the means for operating the head-blocks is simplified and cheapened.

I claim as my invention—

The ratchets C, keyed to the setting-shaft B, disks D, with their arms E, pawls *r*, and segmental cog *v*, pinion F, and lever G, all arranged to operate substantially as set forth.

FRANKLIN J. STALEY.

Witnesses:

H. C. SMITHER,
P. CURRY.