

No. 767,952.

PATENTED AUG. 16, 1904.

C. H. MORSE.
BLOCK SIGNAL.

APPLICATION FILED MAY 22, 1903.

NO MODEL.

3 SHEETS—SHEET 1.

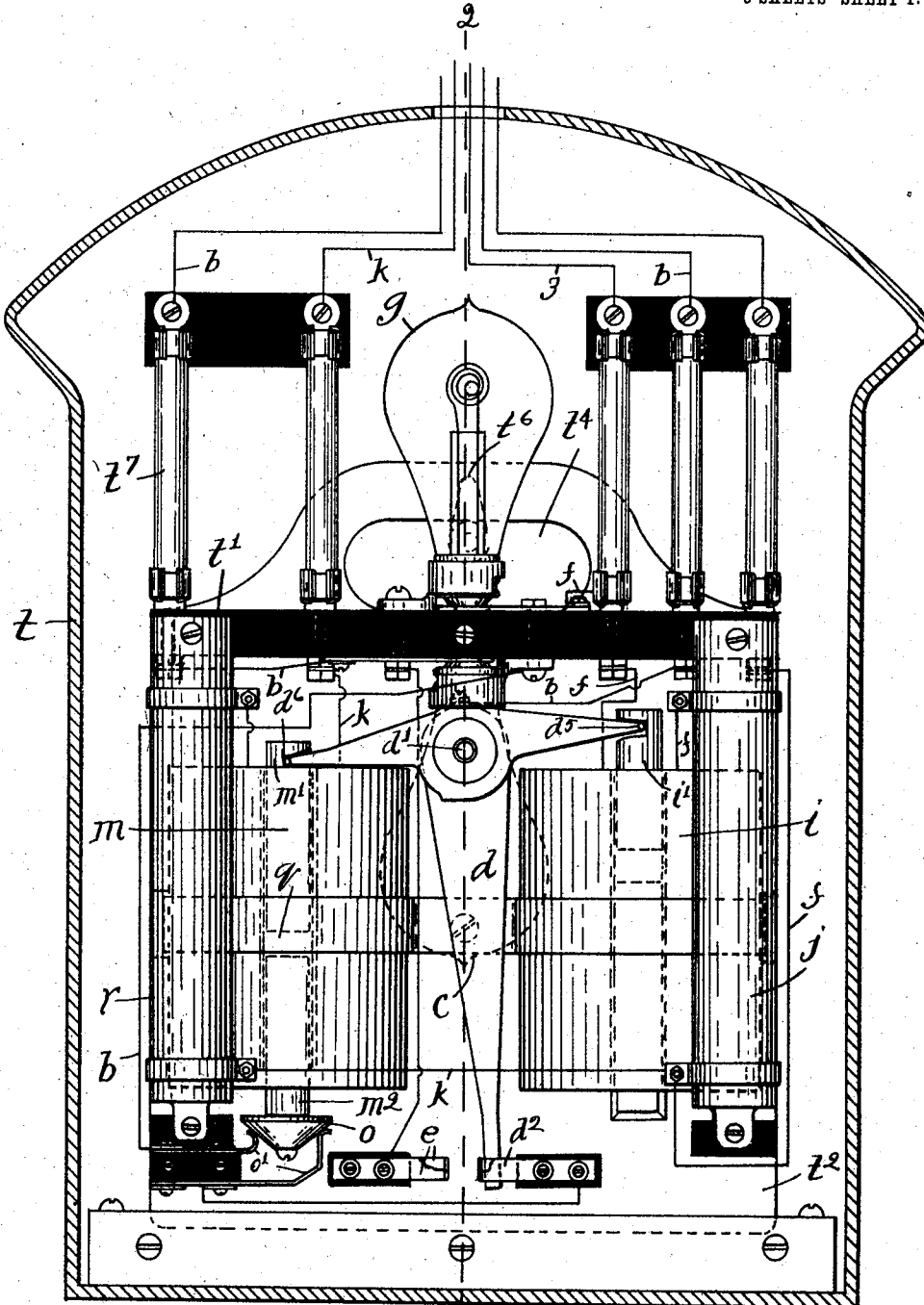

Witnesses:
H. B. Davis,
Maud M. Piper.

Fig. 1.

Inventor:
Charles H. Morse
by *Hayes & Harriman*
Attys

No. 767,952.

PATENTED AUG. 16, 1904.

C. H. MORSE.
BLOCK SIGNAL.

APPLICATION FILED MAY 22, 1903.

NO MODEL.

3 SHEETS—SHEET 2.

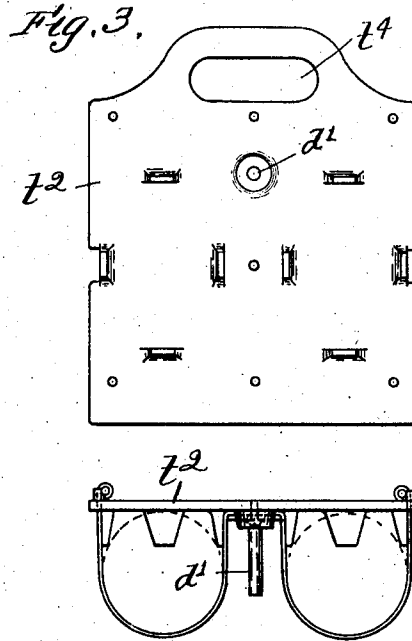
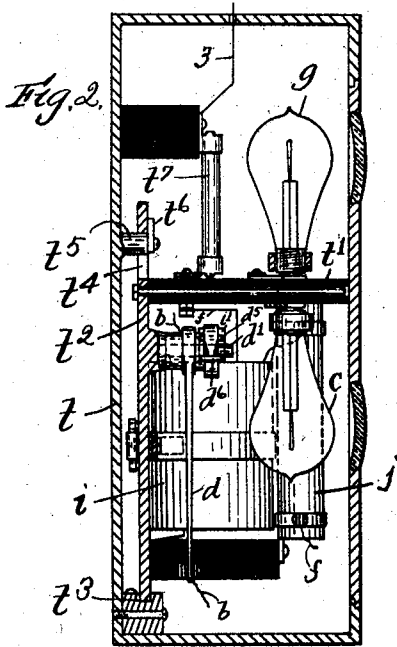

Fig. 4.

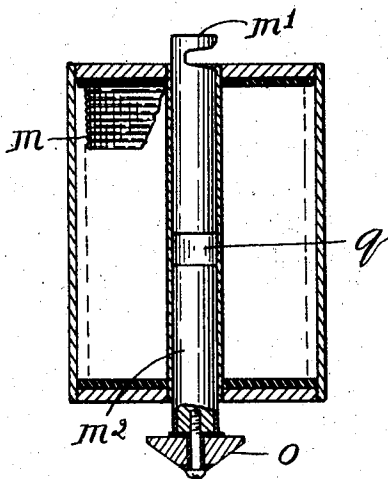

Fig. 5.

Witnesses:

H. B. Davis.

Maud M. Fisher.

Inventor:

Charles H. Morse
by *[Signature]*
Attor

C. H. MORSE,
BLOCK SIGNAL.

APPLICATION FILED MAY 22, 1903.

NO MODEL.

3 SHEETS—SHEET 3.

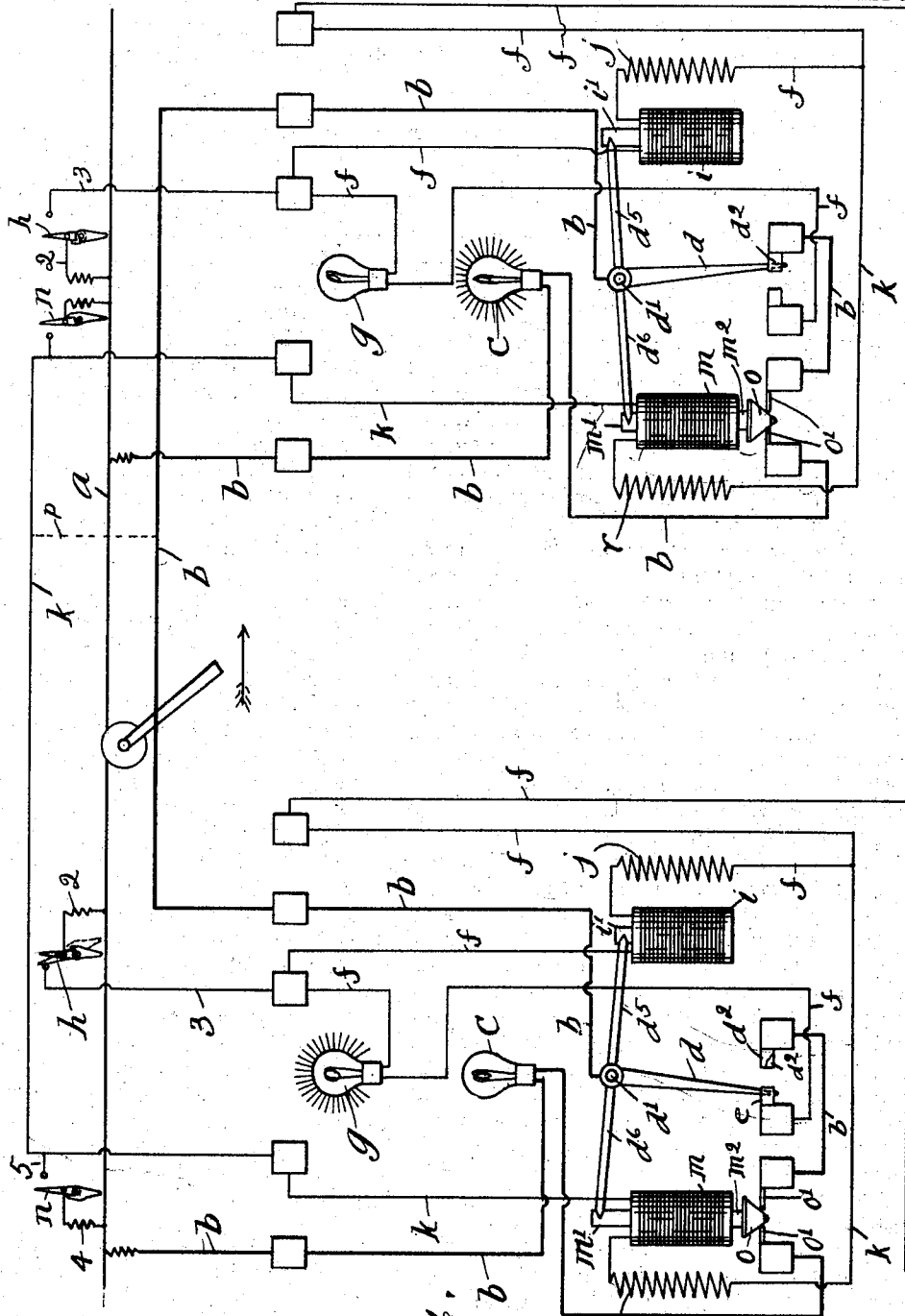

Witnesses:
 H. B. Davis.
 Mand M. Piper.

Fig. 6.

Inventor:
 Charles H. Morse.
 By Thomas H. Harrison
 Atty

UNITED STATES PATENT OFFICE.

CHARLES H. MORSE, OF CAMBRIDGE, MASSACHUSETTS, ASSIGNOR TO THE
UNI SIGNAL COMPANY, OF CAMBRIDGE, MASSACHUSETTS, A CORPO-
RATION OF MAINE.

BLOCK-SIGNAL.

SPECIFICATION forming part of Letters Patent No. 767,952, dated August 16, 1904.

Application filed May 22, 1903. Serial No. 158,236. (No model.)

To all whom it may concern:

Be it known that I, CHARLES H. MORSE, of Cambridge, county of Suffolk, State of Massachusetts, have invented an Improvement in Block-Signals, of which the following description, in connection with the accompanying drawings, is a specification, like characters on the drawings representing like parts.

This invention relates to block-signals of the type especially adapted for use as trolley-signals for electric railways. Block-signals usually have a danger-signal of this type and a safety-signal at each end of the block adapted to be set by means operated by the car when entering the block and to be put out by means operated by the car when leaving the block, the current for said signals (if incandescent lamps are employed as signal-lamps) and the current for operating the means provided for setting and putting out the signals being taken from the trolley-wire or other current-carrying wire.

This invention has for its object to simplify the construction of the operating mechanism in several particulars; to provide a signal-controlling switch at each end of the block adapted to occupy two positions, one to set and the other to put out the signals, and to provide means for holding the arm of said switch in either of the aforesaid positions; to provide mechanical connections between the arm of said switch and the armatures of the lighting-magnet and put-out magnet, whereby said switch-arm is positively operated by said magnets; to provide means for reducing the attractive force of the put-out magnets adapted to be operated and controlled by the lighting-magnets, whereby the pull of said put-out magnets is reduced to such an extent as not to overpower the pull of the lighting-magnets, and thereby restore the set signals in case said put-out magnets should become accidentally energized; to provide a second switch for the signal-circuit at each end of the block, which is operated by the put-out magnet thereat to open said signal circuit, and thereby deenergize the lighting-magnet in order that the pull of the put-out magnet

may be sufficient to reset the signal-controlling switch and restore the set signals, and to provide a support for all or essentially all of the operating parts of the box which is removably connected in the box, so that it may be removed easily with all the parts assembled thereon.

Figure 1 shows in front elevation a trolley signal-box embodying this invention, the shell or case of the box being shown in vertical section. Fig. 2 is a vertical section of the trolley signal-box shown in Fig. 1, taken on the dotted line 2 2, but on a smaller scale. Fig. 3 is a detail showing in front elevation the removable back plate which supports all the essential parts assembled. Fig. 4 is a detail showing in plan view the removable back plate and the lighting-magnet and put-out magnet supported thereon. Fig. 5 is a vertical section of the put-out magnet, which is represented as a solenoid having a main and a secondary armature. Fig. 6 is a diagram of the circuits and operating parts in the positions they will occupy when the car is on the block and going in a direction toward the right as represented by the arrow.

a represents the trolley-wire or other current-carrying wire. The signal-wire *b* is permanently connected to the trolley-wire at each end of the block and at each end of the block passes through the box which contains the visual signals and operating parts therefor, and for the sake of clearness said signal-wire is represented in diagram, Fig. 6, by a wide line.

In each box the visual signal *c* is included directly in the signal-wire, and said signal is herein shown as an incandescent lamp, and this signal is intended to serve as the danger-signal. In each box a switch is provided, herein called the "signal-controlling" switch, which is adapted to normally hold the signal-wire *b* closed, but when operated or moved in one direction to open said signal-wire and also to connect one part or end of said signal-wire with a ground-wire to thereby complete or establish a circuit, herein called the "signal-circuit." This switch constitutes the signal-

controlling switch for setting the signals, and the circuit established by it when operated leads from the trolley-wire *a* or other current-carrying wire at the remote or distant end of the block to the ground at the opposite end of the block.

The signal-controlling switch consists of an arm or blade *d*, depending from a pivot *d'* and normally occupying approximately a vertical position, and a pair of spring-acting contact fingers or plates *d''*, which receive between them, and thereby engage, the lower end of said arm or blade *d* when the switch-arm is in the position to hold the signal-wire *b* closed. The spring-acting contact-fingers *d''* engage and hold the arm *d* frictionally, so that a little pull is required to disengage said arm.

Normally the switch-arms of both boxes will occupy the position shown in the right-hand box, Fig. 6, and consequently the signal-wire *b* is closed at each end of the block. When the switch-arm *d* is moved out of engagement with the contact-fingers *d''*, it will be moved into engagement with a pair of like spring-acting contact-fingers *e*, which are connected with a ground-wire *f*, and these fingers, like the fingers *d''*, engage said switch-arm frictionally and hold it in such a manner that a little pull is required to thereafter disengage it.

The ground-wire *f*, to which the contact-fingers *e* are connected, directly includes in each box a visual signal *g*, which is herein shown as an incandescent electric lamp and is intended to serve as the safety-signal.

Whenever the switch-arm *d* is moved from right to left, the signal-wire *b* will be opened and the ground-wire *f* connected to one of the disconnected ends of the signal-wire, and consequently the safety-signal *g* will be included in the circuit thus established at the box wherein said switch-arm is moved, and thereby set or caused to glow, and the circuit including the signal-wire *b* being thus established the danger-signal *c* at the opposite end of the block will be also set or caused to glow. In the diagram shown in Fig. 6 the signal-controlling switch of the left-hand box is thus moved, and the safety-signal *g* in said box is set, and the danger-signal *c* at the opposite end of the block is also set.

At each end of the block means are provided for operating the signal-controlling switch thereat to set the signals at both ends of the block, and said means is adapted to be operated by the trolley-wheel as the car enters the block. The means herein shown for accomplishing this result consists, essentially, of a circuit-closing device *h*, arranged in such proximity to the trolley-wire as to be operated by the trolley-wheel, one member of said device being connected by a wire 2 permanently with the trolley-wire and the other member being connected by a wire 3 with the ground-wire *f*, and whenever the trolley-

wheel passes beneath either circuit-closing device *h* the said device is operated by said wheel and the ground-wire *f* momentarily connected to the trolley-wire and the circuit thereby established, which includes the wire 2, circuit-closing device *h*, wire 3, and ground-wire *f*.

An electromagnet *i* is included directly in the ground-wire *f*, which, as herein shown, is made as a stopped-coil solenoid, and also in said ground-wire *f* a suitable resistance *j* is included. The solenoid *i* is vertically disposed, and the projecting end of its armature *i'* has a notch or recess which receives the outer end of an arm *d''*, which is rigidly connected to the arm *d* of the signal-controlling switch and which works on the pivot *d'*. It is obvious that the arm *d''* may be otherwise connected with said armature, so as to be operated positively by it.

Normally the ground-wire *f* is open at each end of the block, as is indicated by the diagram at the right hand of Fig. 6, and consequently the solenoid *i* is normally deenergized and its armature retracted; but whenever the circuit-closing device *h* is momentarily closed by the trolley-wheel passing beneath it and the circuit including the ground-wire *f* established then the solenoid *i* attracts its armature and moves the arm *d''* and correspondingly moves the switch-arm *d* from the position shown at the right, Fig. 6, to the position shown at the left, Fig. 6, which opens the signal-wire *b* at *d''* and closes the ground-wire *f*, with the signal-wire *b* at *e*. The solenoid *i* therefore serves as the means for positively moving the signal-controlling switch-arm to set the signals and constitutes the lighting or signal-setting magnet.

The current which passes from the trolley-wire over the wires 2 and 3 and ground-wire *f* is only momentary, but is sufficient to energize the solenoid *i* in order that the latter may perform its work of moving the switch-arm *d*. The switch-arm *d* when in engagement with the contact-fingers *e* positively connects the ground-wire, including the safety-signal *g*, with the signal-wire *b* in such manner as to take the current from the opposite or leaving end of the block, and as the danger-signal *c* is directly included in said signal-wire *b* at said leaving end of the block and has not been cut out by the switch-arm *d* thereat it is set, whereas the danger-signal *c* at the entering end of the block is cut out by the movement of the switch-arm *d* above described.

The operation of the parts caused by the car entering the block from either end is the same and is as follows: The circuit-closing device *h* is operated by the trolley-wheel, and the current from the trolley-wire passes over the wires 2 and 3 and ground-wire *f* and energizes the solenoid *i*, and as the armature of said solenoid *i* attracts the switch-arm *d* is moved out of engagement with the contact-fingers *d''*

and into engagement with the contact-fingers e , thereby opening the signal-wire b at d^2 and cutting out the danger-signal c at the entering end of the block and closing the ground-wire f with the signal-wire b at the entering end of the block, including the safety-signal g , and the current is taken from the far or leaving end of the block over the signal-wire b , which includes the danger-signal c and switch-arm d at the leaving end of the block and the switch-arm d , contact-fingers e , and ground-wire f at the entering end of the block. The safety-signal g is thus set at the entering end of the block and the danger-signal c is set at the leaving end of the block. While the signals are thus set, if a loss of current occurs the signal-lamps will cease to glow; but the armature i' of the solenoid i will remain in its attracted position by gravity, and the switch-arm d will remain in engagement with the spring contact-fingers e by friction, so that when the current restores, the parts being in the same position as when the current ceased, the signal-lamps will again glow.

To put out the signals when the car leaves the block, means are also provided adapted to be operated at either end of the block for positively moving the signal-controlling switch-arm d at the entering end of the block back to its normal position.

The put-out mechanism comprises a put-out wire k , which extends from end to end of the block, which passes through the boxes, and is permanently grounded at each end of the block by any suitable ground connection—as, for instance, it may be connected to the aforesaid ground-wire f . In each box an electromagnet is included in the put-out wire k , herein shown as a solenoid m , having a tubular core open from end to end and containing two armatures m' m'' , disposed in alinement and movable into and out of the tubular core in opposite ways. The armature m' is herein referred to as the "main" armature and the armature m'' the "secondary" armature. The armature m' has a notch which receives the outer end of an arm d^6 , which is rigidly connected with the pivoted switch-arm d , so as to positively move said switch-arm and also be moved by said switch-arm, although any other connection may be provided between the armature and arm d^6 that is desired.

Whenever the switch-arm d is moved by the lighting-magnets out of engagement with the contact-fingers d^2 and into engagement with the contact-fingers e , the armature m' will be moved into its retracted position, and whenever the armature m' is attracted the switch-arm d will be disengaged from the contact-fingers e and moved into engagement with the contact-fingers d^2 and the armature i' moved into its retracted position. Between the solenoid m and ground-terminal a resistance r is included.

To energize the solenoid m , current is taken

from the trolley-wire a , and at each end of the block a circuit-closing device n is provided which is located in such proximity to the trolley-wire as to be engaged by the trolley-wheel, and one member of said circuit-closing device is connected by the wire 4 with the trolley-wire and the other member is connected by a wire 5 to the put-out wire k , and whenever said circuit-closing device is operated the current passes from the trolley-wire over the wires 4 and 5 to the put-out wire and thence to the ground through the solenoid m . The operation of the circuit-closing device is of course only momentary, yet sufficient to cause the solenoid m to become energized. The solenoids at both ends of the block will be energized by the operation of either circuit-closing device n ; but as the armature m' of the solenoid at the leaving end of the block is already in its attracted position it will not be moved.

The signal-circuit when established includes the permanent connection with the trolley-wire at the leaving end of the block and the ground connection f at the opposite or entering end of the block, and in addition to the signal-lamps c and g glowing the solenoid i at the entering end of the block is kept energized, and therefore continues to positively hold the signal-controlling switch-arm d in the position shown at the left of Fig. 6, and it is desired and intended that the pull of the solenoid m at such time shall not be sufficient to overcome the pull of the solenoid i and will only operate when the solenoid i is deenergized. In carrying out this part of my invention the attractive force of the solenoid m for its armatures is reduced when the lighting-magnet operates and sets the signals by means to be hereinafter described, and a second switch or circuit-breaker is provided at each end of the block, which is included in the signal-wire b and which is herein shown as a plug o , normally engaging a pair of contact-plates o' , which are connected with the signal-wire, and said switch normally maintains said signal-wire closed; but when the plug o is moved out of engagement with said plates o' the signal-wire at this point will be opened.

For simplicity of construction the plug o is connected with the secondary armature m'' of the solenoid m , so as to be operated by it whenever said solenoid is energized. Therefore whenever one of the circuit-closing devices n is operated to connect the put-out wire with the trolley-wire or other current-carrying wire and both solenoids m m energized both switches o o' will be operated, and the operation of the one that is located at the leaving end of the block opens the signal-circuit b , causing the solenoid i at the opposite or entering end of the block to deenergize, and thereby permit the solenoid m at said entering end of the block to attract its main armature m' and restore the switch-arm d . The

operation of the switch $o o'$ at the entering end of the block will produce no result. Thus to restore the switch-arm d both solenoids m are required to operate, one to lift, and thereby open the second switch or circuit-breaker $o o'$, which controls the signal-circuit, and the other to attract its main armature, and thereby positively return the switch-arm d when permitted so to act by the solenoid i becoming deenergized.

In case the signal-circuit and put-out wire k should become crossed while the signals are set, it is necessary to prevent the put-out wire, which under such circumstances would take current from the signal-wire, from operating to put out or restore the signals. Such a cross is indicated by the dotted line p , Fig. 6, and the current will pass from the signal-circuit b to the put-out wire k and then through the solenoid m at the right-hand end of the block to the ground, and immediately the secondary armature m^2 will be attracted and the plug-switch $o o'$ opened, thereby opening the signal-circuit, and as soon as said signal-circuit is thus opened the armature m^2 will immediately retract and the switch $o o'$ again close the signal-circuit. This operation will be repeated rapidly while the wires are thus crossed. Hence the plug-switch $o o'$ thus rapidly opening and closing the signal-circuit, or, in other words, vibrating, will visually indicate that the put-out wire and signal-circuit are connected, the armature m' of the solenoid m at the right-hand or leaving end of the block being in its attracted position at such time will not be affected. In case the wires are thus crossed the current will also pass through the put-out wire and through the solenoid m at the opposite or entering end of the block, and it is of the utmost importance that the solenoid m thereat should not be energized sufficiently to attract its armature m' , because in such case the signal-controlling switch-arm d would be restored and the safety-signal g restored to normal or extinguished. Each solenoid m is therefore constructed to exert a variable attractive force on its armature, so that the solenoid m at the entering end of the block may be adjusted in such manner that its attractive force is materially reduced, and as a result it will not overcome the pull of the solenoid i and also will not attract its armatures as quickly as the solenoid m at the opposite or leaving end of the block. This variation in the attractive force exerted is obtained by providing an air-gap in the core of the solenoid of varying dimensions, and when the air-gap is large the attractive force of the solenoid is correspondingly less than when said air-gap is small. This air-gap is represented at q , Fig. 5, and in said figure is reduced to its minimum size, as it will be in the solenoid at the leaving end of the block when the signals are set; but in the solenoid at the enter-

ing end of the block when the signals are set the armature m' is withdrawn from the core mechanically by the lighting-magnet into its retracted position and the air-gap is increased to such an extent that the attractive force of the solenoid is materially diminished, and as a result the solenoid becomes slower to act. Therefore in case of a cross connection between the signal-wire and put-out wire the solenoid m at the leaving end of the block will act sooner than the solenoid m at the entering end of the block and will open the signal-circuit before the solenoid m at the entering end of the block can act, and it will also be seen that in case the put-out wire receives current from the signal-wire or the trolley-wire or other current-carrying wire the armature m' of the solenoid at the entering end of the block will not be attracted and operate the signal-controlling switch and restore the signals unless the lighting-magnet i is first deenergized.

The signal-lamps and operating devices therefor are contained in a suitable box or case t , and for simplicity of construction and ease of inspection and repair the signal-lamps are attached to a shelf t' , which is secured to a back plate t^2 , removably connected to the box, its lower edge resting in a groove formed in a ledge t^3 and its upper edge having a hole t^4 through it of suitable size to receive the hand of the inspector, through which projects a boss t^5 , having a turn-button t^6 pivoted to it, which is adapted to be turned into position to engage the back plate.

The solenoids i and m are mounted on said back plate t^2 , and so, also, are the resistance-coils and switch-arm d and spring-acting contact-fingers d^2 and c . On top of the shelf t' several pairs of contact-fingers are provided which receive the lower ends of the fuses t^7 , which complete the electric connection between the outside wiring and the box-wiring, said fuses being removable. By removing the fuses or disengaging their lower ends from the contact-fingers and then turning the button t^6 the back plate and all the parts mounted upon and supported by it may be removed in assembled position.

Having thus described my invention, what I claim as new, and desire to secure by Letters Patent, is—

1. In a block-signal having a danger-signal and a safety-signal at each end of the block, and circuits therefor, a signal-controlling switch at each end of the block, means for holding the arm of said switch in either of its positions, a lighting-magnet, and a put-out magnet at each end of the block and circuits therefor, and a mechanical connection between the armatures of said magnets and the switch-arm, whereby said switch-arm is positively moved in opposite ways, by said magnets, and the armature of the deenergized magnet positively retracted, means for operating the

put-out circuit and means for simultaneously opening the signal-circuit, substantially as described.

2. In a block-signal having a danger-signal and a safety-signal at each end of the block and circuits therefor, a signal-controlling switch at each end of the block, a lighting-magnet and a put-out magnet at each end of the block for operating the switch thereat, circuits therefor, and means operated by said lighting-magnet for reducing the attractive force of the adjacent put-out magnet, substantially as described.

3. In a block-signal having a danger-signal and a safety-signal at each end of the block, and circuits therefor, a signal-controlling switch at each end of the block, a lighting-magnet and a put-out magnet at each end of the block for operating the switch thereat, and a second switch at each end of the block, one for each signal-circuit, each operated by the adjacent put-out magnet, substantially as described.

4. In a block-signal having a danger-signal and safety-signal at each end of the block, and circuits therefor, a signal-controlling switch at each end of the block, a lighting-magnet and a put-out magnet at each end of the block for operating the switch thereat and a second switch at each end of the block operated by the put-out magnet thereat, which control the signal-circuits, substantially as described.

5. In a block-signal having a danger-signal and safety-signal at each end of the block and circuits therefor, a signal-controlling switch at each end of a block, a lighting-magnet and a put-out magnet at each end of the block for operating the switch thereat and a second switch at each end of the block operated by the put-out magnet thereat which control the signal-circuits, and means operated by each lighting-magnet for reducing the attractive force of the adjacent put-out magnet, substantially as described.

6. In a block-signal having a danger-signal and a safety-signal at each end of the block, and circuits therefor, a signal-controlling switch at each end of the block, a lighting-magnet and a put-out magnet at each end of the block, arms connected with the arm of the switch which engage the armatures of said magnets, means for holding the switch-arm with either one of the armatures attracted and the other retracted, a circuit for said lighting-magnet and means for operating it, and a circuit for said put-out magnet, and means for operating it and means for opening the said signal-circuit, substantially as described.

7. In a block-signal having a danger-signal and safety-signal at each end of the block, and circuits therefor, a signal-controlling switch at each end of the block, a lighting-magnet and a put-out solenoid at each end of the block, means for mechanically connecting the armatures of said magnets and solenoids with the

arms of the signal-controlling switches, a second switch at each end of the block which control the signal-circuits and means for operating it consisting of a secondary armature arranged to be operated by the put-out solenoid, substantially as described.

8. In a block-signal having a danger-signal and a safety-signal at each end of the block, and circuits therefor, a signal-controlling switch at each end of the block, a lighting-magnet and a put-out solenoid at each end of the block, the attractive force of the latter being reduced by the retraction of its main armature, arms connected with the arm of said switch which engage the armatures of said magnets and solenoids, means for holding the switch-arm with either one of the said armatures attracted and the other retracted, a second switch at each end of the block which control the signal-circuits and means for operating it consisting of a secondary armature for the put-out solenoid, circuits for the lighting-magnets and a circuit for the put-out solenoids, and means for operating said circuits, substantially as described.

9. In a block-signal having a danger-signal and a safety-signal at each end of the block, and circuits therefor, a signal-controlling switch at each end of the block; a lighting-magnet and a put-out solenoid at each end of the block for operating the switch thereat, arms connecting the arm of the signal-controlling switch at each end of the block with the armatures of the adjacent lighting-magnets and put-out solenoids, whereby the attracted movement of the armature of either lighting-magnet moves the armature of the adjacent put-out solenoid into its retracted position, and thereby reduces the attractive force of said solenoid at the same time that it moves the signal-controlling switch, substantially as described.

10. In a block-signal having a danger-signal and a safety-signal at each end of the block, and circuits therefor, a signal-controlling switch at each end of the block, a lighting-magnet and a put-out magnet at each end of the block for operating the switch thereat, the attractive force of said put-out magnet being reduced by the retraction of its armature, arms connected with the arm of said switch which engage the armatures of said magnets, whereby the attracted movement of the lighting-magnet moves the armature of its adjacent put-out magnet into its retracted position, means for holding the switch-arm with either one of said armatures attracted and the other retracted, a second switch at each end of the block which control the signal-circuits, and means for operating it, substantially as described.

11. In a block-signal having a danger-signal and a safety-signal at each end of the block, and circuits therefor, a signal-controlling switch at each end of the block for setting the

signals and for including the adjacent lighting-magnet in the signal-circuit, a lighting-magnet at each end of the block having a gravitating armature connected with the signal-controlling switch thereat, and means for putting out the signals and for lifting said gravitating armature into its retracted position, substantially as described.

12. In a block-signal having a danger-signal and a safety-signal at each end of the block and circuits therefor, a signal-controlling switch at each end of the block, a lighting-magnet and a put-out magnet at each end of the block, mechanical connections between the armatures of the lighting-magnet and put-out magnet and signal-controlling switch at each end of the block, whereby the signal-controlling switches are moved one way by the lighting-magnets to set the signals and lift the armatures of the adjacent put-out magnets, and are moved the opposite way by the put-out magnets to extinguish the signals and lift the armatures of the adjacent lighting-magnets, circuits for said lighting-magnets and put-out magnets and means for operating said circuits, substantially as described.

13. In a block-signal having a danger-signal and a safety-signal at each end of the block and circuits therefor, a signal-controlling switch at each end of the block, a lighting-magnet and a put-out magnet at each end of the block, each having a gravitating armature, circuits therefor, mechanical connections between the armatures of the lighting-magnet and put-out magnet and signal-controlling switch at each end of the block whereby said switch is moved positively in opposite ways and the armature of the deenergized magnet lifted, and a second switch at each end of the block operated by the put-out magnet thereat which control the signal-circuits, substantially as described.

14. In a block-signal having a danger-signal and a safety-signal at each end of the block and circuits therefor, a signal-controlling switch at each end of the block, a lighting-magnet and a put-out magnet at each end of the block, mechanical connections between the armatures of the lighting-magnet and put-out magnet and signal-controlling switch at each end of the block, whereby the signal-controlling switches are moved one way by the lighting-magnets to set the signals and lift the armatures of the adjacent put-out magnets, and are moved the opposite way by the put-out magnets to extinguish the signals and lift the armatures of the adjacent lighting-magnets, and means for holding the switches in either position that they may be set, substantially as described.

15. In a block-signal having a danger-signal and a safety-signal at each end of the block and circuits therefor, a signal-controlling switch at each end of the block, a lighting-

magnet and a put-out magnet at each end of the block for operating the switch thereat, a second switch at each end of the block, one for each signal-circuit and means controlled by the put-out circuit for operating said second switches to thereby open the signal-circuits and permit the put-out magnets to restore the signal-controlling switch, substantially as described.

16. In a block-signal having a danger-signal and a safety-signal at each end of the block and circuits therefor, a signal-controlling switch at each end of the block, a lighting-magnet at each end of the block for operating the signal-controlling switch thereat, which is included in the signal-circuit when the signal is set, means for operating said lighting-magnets, a put-out magnet at each end of the block for also operating the signal-controlling switch thereat, circuits for said put-out magnets and a second switch at each end of the block, one for each signal-circuit, and means controlled by the put-out circuits for operating said second switches to thereby open the signal-circuits and permit the put-out magnets to operate, substantially as described.

17. In a block-signal having a danger-signal and a safety-signal at each end of the block, and circuits therefor, a signal-controlling switch at each end of the block, a lighting-magnet at each end of the block for operating said signal-controlling switches, and for holding them with the signals set, a put-out magnet at each end of the block for also operating said signal-controlling switches to extinguish the signals, circuits for said put-out magnets, means for operating said circuits and a second switch at each end of the block for opening the signal-circuit to deenergize the lighting-magnet included therein, and permit the return of the signal-controlling switch, substantially as described.

18. In a block-signal having a danger-signal and a safety-signal at each end of the block and circuits therefor, a signal-controlling switch at each end of the block having a pivoted switch-arm, a vertically-disposed lighting-solenoid at each end of the block, the armature of each lighting-solenoid being connected with the adjacent pivoted switch-arm, and a vertically-disposed put-out solenoid at each end of the block, the armature of each put-out solenoid being connected with the adjacent pivoted switch-arm, circuits for said lighting-solenoids and put-out solenoids and means for operating said circuits, substantially as described.

In testimony whereof I have signed my name to this specification in the presence of two subscribing witnesses.

CHARLES H. MORSE.

Witnesses:

B. J. NOYES,
H. B. DAVIS.