

(No Model.)

S. V. COOK.
Ice Elevator.

Patented Dec. 7, 1880.

No. 235,128.

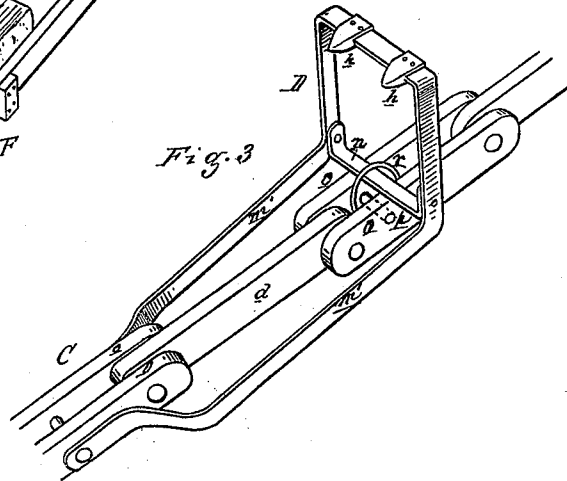
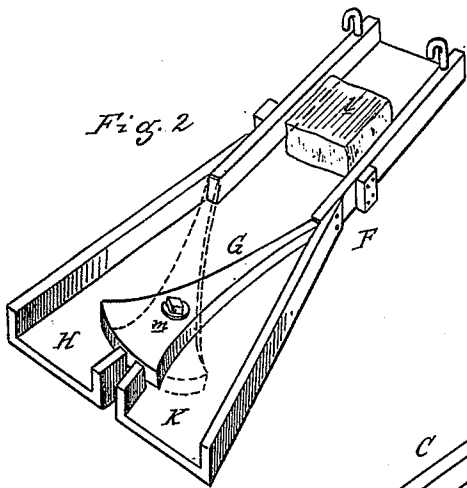
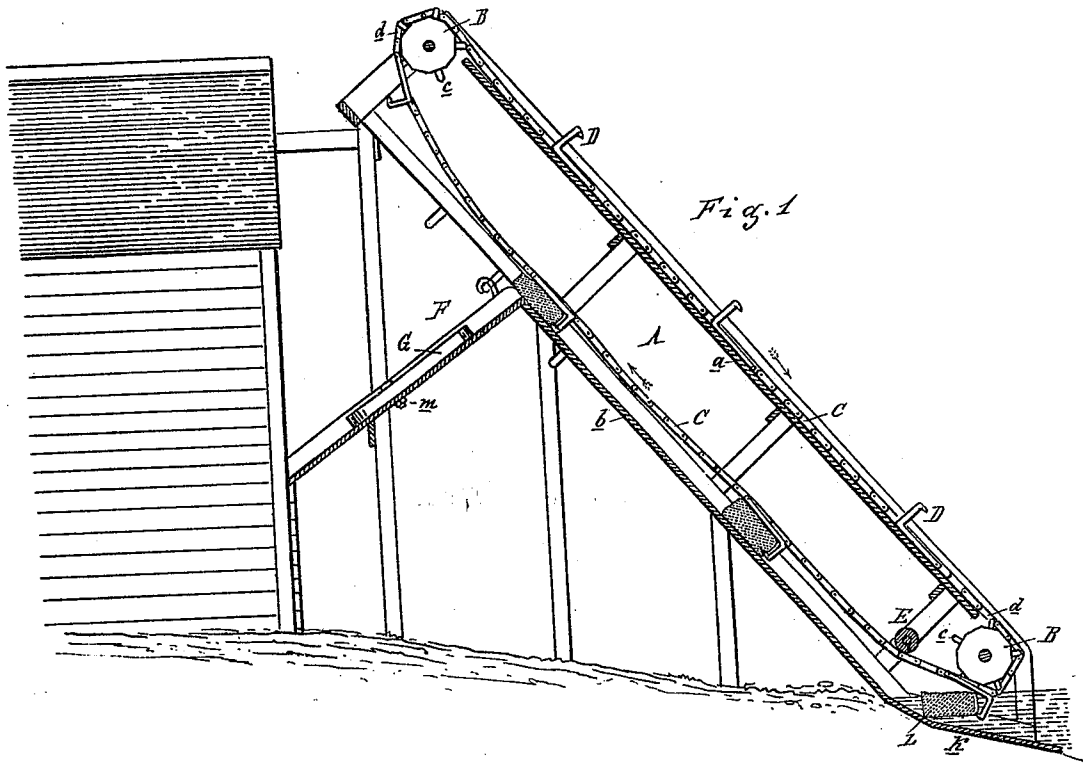

Attest:
A. Barthel
W. F. Sprague

Inventor:
S. V. Cook
By Atty.
W. F. Sprague, Atty

UNITED STATES PATENT OFFICE.

STEPHEN V. COOK, OF TOLEDO, OHIO.

ICE-ELEVATOR.

SPECIFICATION forming part of Letters Patent No. 235,128, dated December 7, 1880.

Application filed October 18, 1880. (No model.)

To all whom it may concern:

Be it known that I, STEPHEN V. COOK, of Toledo, Lucas county, Ohio, have invented a new and useful Improvement in Ice-Elevators, of which the following is a specification.

The nature of this invention relates to certain new and useful improvements in that class of elevators employed for taking ice from the place where it is cut, and delivering the same into the house where it is to be stored.

The invention consists in the peculiar construction and arrangement of the parts, as hereinafter more fully set forth, and pointed out in the claim.

Figure 1 is a vertical central section, the lower end resting in the water, while the upper end is designed to rest against the ice-house, although it is shown as supported by legs in the drawings. Fig. 2 is an enlarged perspective view of the switch-chute upon which the cakes are received from the elevator, and alternately shunted to different directions. Fig. 3 is an enlarged perspective view of the chain and buckets thereto attached.

In the accompanying drawings, which form a part of this specification, A represents an elevator-frame provided with an upper floor, a, and a lower floor, b.

Upon suitable shafts journaled in the two sides of the frame are the two sprocket-wheels B, over and around which runs the chain C. These sprocket-wheels are polygonal in form, and upon each of the flat sides, or upon every alternate one, are the rigid spurs or studs c, designed to embrace the single bar or link d, and strike against the ends of the two bars o, pivoted to the ends of the single bar, d, which form the chain C, there being alternate single and double bars forming the links.

To the double bars o, and at suitable distances apart, are pivoted the bails m' of the buckets D, as shown in Fig. 3, and these may be provided with small spurs h, if desired.

To prevent the buckets from being revolved over on their pivots as they pass around the upper sprocket-wheel in the rapid movement

of the belt, and thus present the buckets in an inoperative position to seize the blocks of ice, I employ the following device to retain the buckets in their proper position on the belt, and prevent their being swung over on their pivots, so that the outer end of the bucket would rest on the endless chain. A transverse bar, n, is secured to the lower ends of each bucket, (see Fig. 3,) which is encircled by a ring, r, the latter also encircling a pin, p, secured to each of the double bars o.

By this construction each bucket is retained in its proper position for seizing the blocks of ice, and is prevented from making a half-revolution on its pivotal points as it passes over the upper sprocket-wheel.

E is an idler-wheel, suitably journaled across the frame, a little distance above the lower sprocket-wheel, to compel the slack of the chain to approach nearer the floor b than it otherwise would.

Motion is given to the sprocket-wheels from any convenient power.

The lower end of the floor B terminates in a platform, k, which projects below and beyond the lower sprocket-wheel, and it is designed, when in use, to be immersed in the water a sufficient depth to allow the cakes of ice to be floated into the mouth of the elevator.

In operation the chain runs down upon the upper floor, a, as indicated by the arrow, and the bale or bucket D falls behind the cake of ice L, and in the further progress of the chain draws the cake along the platform k and floor b, passing underneath the idler E to the end of the floor b, where the ice is delivered upon the chute F. This chute is provided with a tongue, G, pivoted to the floor of the chute at m, and is of the shape shown in Fig. 2, so that the first cake of ice l' passes to the chute H, and in so doing throws the switch over, so that the next cake is diverted to the other chute, K, and so on, alternately, each cake of ice turns the switch for the succeeding one.

If desired, the chutes H and K may each be provided with a similar switch, each leading to two additional chutes, and so the sys-

tem of automatic shunting may be extended as far as desired.

What I claim as my invention is—

In an ice-elevator, the combination, with
5 the sprocket-wheels B and endless chain C,
having alternate double and single links, of
the buckets D, provided with bails m' , each

pivoted to a double link, transverse bar n ,
pin p , and ring r , substantially as described,
and for the purpose set forth.

STEPHEN V. COOK.

Witnesses:

H. S. SPRAGUE,
CHARLES J. HUNT.